



Cape Peninsula  
University of Technology

**DEVELOPMENT OF AN ENERGY MODEL IN SYSTEM MODELING LANGUAGE  
FOR FUTURE AUTOMATED RESIDENTIAL BUILDING APPLICATIONS**

**By**

**MUTONDO PAUL MATENDA**

**Thesis submitted in fulfilment of the requirements for the degree  
Master of Technology: Electrical Engineering in the Faculty of Engineering  
at the Cape Peninsula University of Technology**

**Supervisor: Dr W. Fritz  
Co-supervisor: Dr A. Raji**

**Bellville  
November 2014**

**CPUT copyright information**

The dissertation/thesis may not be published either in part (in scholarly, scientific or technical journals), or as a whole (as a monograph), unless permission has been obtained from the University.

## DECLARATION

I, Mutondo Paul Matenda, declare that the contents of this dissertation/thesis represent my own unaided work, and that the dissertation/thesis has not previously been submitted for academic examination towards any qualification. Furthermore, it represents my own opinions and not necessarily those of the Cape Peninsula University of Technology.

---

**Signed**

---

**Date**

## ABSTRACT

Today the building energy modeling industry is facing a number of challenges, the advanced programs or methods developed for building energy modeling, are very technical and complex to be used, especially for earlier designs, and the easy programs or methods are not accurate. Moreover, more than a hundred programs developed for energy modeling, have been used in the same building, but most of the time the results differed by about 30%. That is why this thesis has developed a new building energy model in System Modeling Language (SysML), in order to meet, at the same time, the accuracy and the simplicity to be used for future and existing buildings. In this thesis, SysML has been used to develop an energy model and to set up an automation system to the existing building. SysML can do more than simulations, but this thesis is limited to only the simulations steps by using easy applications of SysML and fewer diagrams which could develop in a complete building energy model. SysML is the extension of Unified modeling Language (UML), which uses fewer diagrams than UML. SysML is simple, open and more flexible to be used in any Engineering System. The previous chapter describes SysML and gives the overview and the platform of SysML.

The simulations of SysML in this project have been developed through Enterprise Architect and Mat lab software. The inputs used to simulate the program are the parameters of the existing building chosen for modeling that is a student residential building complex located in Stellenbosch, Western Cape in South Africa. Automation system program used in this thesis was based on the norms and building standards of South Africa, renewable energy and the requirements of the buildings' occupants, in order to meet energy efficiency and safety of the occupants. Concerning automation system, this thesis have described the main components in the previous chapters, and enumerated some most widely used standards bus. In the modelling phase, only the states of automation system have been described through SysMLs' activities diagrams without calibrating automation systems' components.

In the complex residential building, lighting and HVACs systems are the large consumers of electrical energy. That is why this thesis brought more light on these systems by enumerating them and giving their strengths and weaknesses, in order to allow architects and building engineers to make adequate selections of lighting and HVAC systems. Regarding HVAC system, this thesis did not size and select the HVAC system equipment, the thesis has determined only the peak loads, and described the daily, monthly and yearly behaviour of the loads. The methods used in this thesis to develop the energy model for cooling and heating loads is Cooling Load Different Temperature (CLTD) method, because this method is simple, well known, common and widely used.

The aim of this thesis was to predict the loads of the building without automation system, and the same building with automation and solar hot water system, in order to compare them and to get an accurate and useful conclusion.

The objective of this thesis is to develop an easy energy model program in System Modeling language, which can be used for building energy model, and to set up an automation system and solar hot water system to the existing building to optimize energy consumption and energy management, in order to meet energy efficiency. This thesis did not complete the cost-pay back analysis and the investment cost of the automation system and solar hot water system.

## ACKNOWLEDGEMENTS

### I wish to thank:

- My Lord for giving me the strength, and assiduity to achieve my target.
- My parents Mutondo Nsase and Kitenge Leontine for so many sacrifices and efforts made throughout my childhood and my studies.
- My darling Katanga Nathalie for sharing with me the big challenges of life.
- My sons Narcisse Mwimbi and Ryan Lusanga who have agreed to sympathise with me as loyal sons.
- My family for their support and encouragement especially Alain Mutondo, Sylvie Mutondo and Fiston Mutondo
- My supervisor and co-supervisor Dr Wilfred Fritz and Dr Atanda Raji for their guidance and teaching me throughout this project with patience and understanding.
- My fellow students for great office in which to talk and share ideas and encouragements: Doudou Luta, , Martial Giraneza, Papy Lukasha, Akim
- My friends Attie, Brenda, Lemmer, Alitta and Belly
- Mr Mutombo Kilaketa, Mr Marc Mbayo for their support and encouragements

### If you have received funding from the NRF, include the following:

The financial assistance of the National Research Foundation towards this research is acknowledged. Opinions expressed in this thesis and the conclusions arrived at, are those of the author, and are not necessarily to be attributed to the National Research Foundation.

## **DEDICATION**

This thesis is dedicated to my Lord, to Narcisse Mwimbi and Ryan Lusanga

## TABLE OF CONTENTS

DECLARATION .....	ii
ABSTRACT .....	iii
ACKNOWLEDGEMENTS .....	v
DEDICATION .....	vi
TABLE OF CONTENTS .....	vii
LIST OF FIGURES.....	ix
LIST OF TABLES .....	xii
APPENDICES .....	xii
Appendix A: SysML diagram developed for building energy modelling .....	xii
Appendix B: Roadmap of System Modeling Language .....	xii
GLOSSARY.....	xiii
CHAPTER ONE.....	1
GENERALITY.....	1
1.1 Introduction .....	1
1.2 Statement of the problem .....	1
1.3 Hypotheses .....	2
1.4 Research aim and objective .....	2
1.5 Delimitation .....	3
1.6 Significance of the research .....	3
CHAPTER TWO.....	4
LITERATURE REVIEW.....	4
2.1 Introduction .....	4
2.2 Electrical energy .....	4
2.2.1 Definition of electrical energy.....	4
2.2.2 Main cause of electrical energy consumption in the residential building .....	4
2.3 Lighting system.....	5
2.3.1 Different kind of electrical lamps .....	6
2.3.2 Light measurement system.....	9
2.3.3 Tubular day lighting.....	12
2.4 Heating ventilation and air condition System (HVAC system).....	13
2.4.1 Definition of Air conditioning .....	13
2.4.2 Aims of Air conditioning.....	13
2.4.3 HVAC Principle of functioning.....	13
2.4.4 Type of HVACs .....	14
2.4.5 Heat pump.....	22
2.4.6 Solar air conditioner .....	32
2.5 Building automation system.....	34
2.5.1 Introduction .....	34
2.5.2 Definition of building Automation .....	34
2.5.3 Utilities.....	34
2.5.4 Structure of building automation and control network.....	35
2.5.5 Energy management functions .....	36
2.5.6 Main components and devices of building automation system .....	38
2.5.7 Standardized bus systems and Networks in building automation systems .....	39
CHAPTER THREE .....	45
BUILDING ENERGY MODELING AND SYSTEM MODELING LANGUAGE .....	45
3.1 Models and simulations .....	45
3.2 System Modelling Language (SysML) .....	45
3.2.1 Definition of system modeling language .....	45
3.2.2 System Modeling Language diagrams.....	46
3.2.3 Advantages of system modeling language .....	52
3.3 Building Energy modelling software .....	53
3.3.1 Department Of Energy 2 (DOE2).....	55
3.3.2 The transient systems simulation (TRNSYS) .....	55
3.3.3 Energy Plus.....	55
3.3.4 SUNREL.....	56
3.3.5 HOT 2000.....	56
CHAPTER FOUR .....	58
BUILDING INFORMATION .....	58
4.1 Building location.....	58
4.2 Overview on the building's South Africa norms and codes .....	58
4.2.1 Building envelope and South Africa norms.....	60

4.2.2	Climate and weather data .....	62
4.3	Building presentation .....	63
4.4	Building systems structure .....	66
4.4.1	Building energy End Uses and structure of automation system in the building .....	66
4.4.2	Electrical plugs loads .....	69
CHAPTER FIVE .....		71
BUILDING ENERGY MODELING AND SIMULATIONS .....		71
5.1	Building and systems structure .....	71
5.1.1	Residential building End Uses .....	80
5.2	Behaviour of Building's system .....	94
5.3	Heating and cooling loads calculation and simulations .....	101
5.3.1	Cooling loads .....	101
5.3.2	Heating load .....	120
5.4	Lighting system load simulations .....	127
5.6	Building loads, automated building versus no-automated building .....	134
CHAPTER SIX .....		139
CONCLUSION AND DISCUSSION .....		139
6.1	Introduction .....	139
6.2	Aims and objectives .....	139
6.3	Discussion .....	140
REFERENCES .....		141
APPENDICES .....		143
APPENDIX A: SysML diagrams developed for building energy modeling .....		143
APPENDIX B: Roadmap of System Modeling Language .....		145



## LIST OF FIGURES

Figure 2.1: Construction of a compact Fluorescent Lamp

Figure 2.2: Fluorescent Lamp Circular and U shaped Lamp.

Figure 2.3: The Standard Fluorescent Lamp.

Figure 2.4: Efficiency of Light sources lumen/watt excluding ballast Lasses.

Figure 2.5: Self Contained wall unit

Figure 2.6: Overview of Variable Air Volume System.

Figure 2.7: Overview of the reversibility of the refrigeration system, heating and cooling

Figure 2.8: Schematic of a Flooded Type and shell-and tube evaporator.

Figure 2.9: The Hierarchy structure in the building automatic.

Figure 2.10: A Ventilation system displayed on a Control Computer deponent

Figure 2.11: Optimum start/stop

Figure 2.12: Limit Peak Lead.

Figure 2.13: Horizontal and vertical Communications in building automation model

Figure 2.14: Building Control with KNX integrated system, Lower Cabling cost

Figure 2.15: Full mesh Topology on left side and Partial mesh topology on right side

Figure 2.16: Star Topology.

Figure 2.17: Tree Topology.

Figure 3.1: System ML and UML relationship.

Figure 3.2: System Modeling Language diagrams.

Figure 3.3: Types Property-alternative representation.

Figure 3.4: Partial meta-model for the Internal Block Diagram.

Figure 3.5: Partial meta-model of the Package Diagram.

Figure 3.6: Partial meta-model of the parametric diagram.

Figure 3.7: Partial meta-model of the state Machine Diagram

Figure 3.8: Partial meta-model of the activity diagram.

Figure 3.9: Partial meta-model and Graphical representation of aliments Use Case Diagram

Figure 4.1 Climatic zone of South Africa

Figure 4.2 Building energy End Uses for residential building

Figure 4.3 Structure of automation system in the residential building

Figure 5.1: Block definition Diagram for the overall residential building.

Figure 5.2: Requirement diagram for residential in South-Africa that describes the structures of building requirements.

**Figure 5.3: Requirements diagram for building structures that definition the main requirement of energy efficiency.**

**Figure 5.4: Domain Model for residential building**

**Figure 5.5: Block Definition Diagram for building structure.**

**Figure 5.6: Block Definition Diagram of Energy and Use in residential building.**

**Figure 5.7: Internal Block Diagram of Energy and Use.**

**Figure 5.8: Requirements diagram of automation system.**

**Figure 5.9: Blocks Definition Diagram of automation system structure.**

**Figure 5.10: Internal Block Diagram of automation system and connectors describes the flow of items in the system.**

**Figure 5.11: Requirement diagram of lighting system that describes main requirement perform lighting System.**

**Figure 5.12: Block Definition Diagram of lighting system that describes the main elements of lighting system.**

**Figure 5.13: Block Definition Diagram describing main parts of hot water system**

**Figure 5.14: Requirement Diagram of that water system that describe the main requirements to hot water system.**

**Figure 5.15: Internal Block Diagram of that water system describing energy and mothers flow .**

**Figure 5.16: Requirement Diagram of HVAC system, enumerating main requirements to which HVAC shall comply.**

**Figure 5.18 Block definition diagram of HVAC system that describes the main components of HVAC system.**

**Figure 5.19: Internal Block Diagram of HVAC system that depicts the structure of HVAC system and Items flow.**

**Figure 5.20 Activity diagram of energy and items flow into the building with Connectors describing items and matter flow.**

**Figure 5.21 Activity diagram of hot water system working according to automation system.**

**Figure 5.22 Activity diagram of that water system working according to automation system.**

**Figure 5.23 Activity of automation system describing the automation' s program Based on the main requirements energy efficiency.**

**Figure 5.24 Different steps to right-size and sleet HVA C system.**

**Figure 5.25 BDD diagram that describes total coding load.**

**Figure 5.26 Block Definition diagram total external coding load a solar heat gain.**

**Figure 5.27 Internal Block Definition expresses heat flow to the conditioned spaces that farm coding load.**

**Figure 5.28 Block Definition Diagram of internal coding load.**

**Figure 5.29 Block Definition Diagram showing constraint blocks for internal coding load.**

**Figure 5.30 Block Definition Diagram showing constraints**

**Figure 5.31 Parametric model for simulating total cooling loads for the building.**

**Figure 5.32 Solar heat gains through fenestration or windows cooling simulation.**

**Figure 5.33 Solar heat gains through external walls daily cooling load of external walls.**

**Figure 5.34 Total external cooling loads that is the sum of heat gains through roof, floor and total gains through external walls and fenestration.**

**Figure 5.35 Peak total daily coding load of the building simulation' s result.**

**Figure 5.36 Block Definition Diagram of total peak heating load.**

**Figure 5.37 Block Definition Diagram of total head losses through external walls and doors.**

**Figure 5.38 Total heat losses through windows.**

**Figure 5.39 Internal Block Definition describing heat losses through the building envelope.**

**Figure 5.40 Total daily heating load during the sunny day in winter season.**

**Figure 5.41 Total daily heating load in June and July.**

**Figure 5.42 BDD describing constraint blocks of lighting system.**

**Figure 5.43 Daily loads of outdoor lights connected to the day light detectors.**

**Figure 5.44 Daily loads of outdoor lights for no-automated building using incandescent lamps.**

**Figure 5.45 Daily loads of indoor lights for automated building using CFLS lamps.**

**Figure 5.46 Daily total loads for indoor and outdoor lights non-automated building.**

**Figure 5.47 Total daily lighting system loads of automated building.**

**Figure 5.48 Describing constraint blocks of hot water system.**

**Figure 5.49 Daily loads of no-automated building in winter season.**

**Figure 5.50 Daily loads of automated building in the weekend day of winter.**

**Figure 5.51 Daily load of automated building in the weekdays of winter season.**

**Figure 5.52 Daily load of no-automated building in summer season.**

**Figure 5.53 Daily load of automated building in summer.**

**Figure 5.54 Yearly energy consumption of no-automated building**

**Figure 5.55 Yearly energy consumption of automated building.**

## **LIST OF TABLES**

**Table 4.1 Minimum Total R-Value of roof assemblies**

**Table 4.2 Metal sheeting roof assemblies**

**Table 4.3 Worse-case Whole Gazing Aliment preferment**

**Table 4.4 Location of South Africa big towns and provinces in such zone**

**Table 4.5 Building information**

**Table 4.6 Building size and form**

**Table 4.7 Overview of yearly average energy consumption by daily appliances in the residential building**

**Table 5.1 Series of Data base used as input in the figure 5.31 for cooling load simulations**

**Table 5.2 Description of lighting systems' characteristics, and the ratio of working per hour to no automated building**

**Table 5.3 Describes lighting system characteristics, and ratio of operating to automated building using compact fluorescent lamps**

**Table 5.4 Daily and monthly energy consumptions of automated building versus no-automated building**

## **APPENDICES**

**Appendix A: SysML diagram developed for building energy modelling**

**Appendix B: Roadmap of System Modeling Language.**

## **GLOSSARY**

<b>Terms/Acronyms/Abbreviations</b>	<b>Definition/Explanation</b>
<b>AC</b>	Alternating current
<b>AS</b>	Automation System
<b>ASHREA</b>	American Society of Refrigeration and Air Conditioning Engineering
<b>ARCNET</b>	Attached Resource Computer Network
<b>AvYEC</b>	Average Yearly energy Consumed by each appliance
<b>BACNET</b>	Building automation and control network
<b>BDD</b>	Block Definition Diagram
<b>BL</b>	Back line
<b>BLAST</b>	Building Load Analysis and System Thermodynamic
<b>Bld</b>	Building
<b>CFC</b>	Chlorofluorocarbon
<b>CFL</b>	Compact Fluorescent Lamp
<b>CLF</b>	Cooling Load Factor
<b>CLTD</b>	Cooling Load Temperature Difference
<b>CENELEC</b>	European Comity of Electro technique Normalisation
<b>DC</b>	Direct Current
<b>DDC</b>	Direct Digital Control
<b>DOP</b>	Daily Operating Period
<b>DME</b>	Department of Mineral and Energy
<b>DOE</b>	Department of Energy
<b>DPW</b>	Department of Power and Water
<b>DX</b>	Direct Expansion
<b>EF</b>	Energy Efficiency
<b>ETC</b>	Evacuated Tube Collector
<b>FPC</b>	Flat Plat Collector
<b>GBCSA</b>	Green Building Council of South Africa
<b>GHG</b>	Green House Gas
<b>GLS</b>	General Light Service
<b>GWP</b>	Global Warming Potential
<b>HCFC</b>	Hydro-chlorofluorocarbon
<b>HVAC</b>	Heating Ventilation and Air Conditioning

<b>HWS</b>	Hot Water System
<b>IBD</b>	Internal Block Definition
<b>IBM</b>	International Business Machines
<b>IEC</b>	International Electro technical Commission
<b>IEEE</b>	Institute of Electrical and Electronics Engineering
<b>INCOSE</b>	International Council on System Engineering
<b>ISO/IEC</b>	International Standard Organization
<b>IPCC</b>	Intergovernmental Panel Climate Change
<b>KNX</b>	Konnex ( European Standard Bus)
<b>KNXPL</b>	Konnex Power Line
<b>KNXRF</b>	Konnex Radio Frequency
<b>KNXTP</b>	Konnex Twisted Pair
<b>LAN</b>	Local Area Network
<b>LED</b>	Light Emitted Diode
<b>LON</b>	Long Term Mitigation Scenarios
<b>LTMS</b>	Matrix Laboratory
<b>MEC</b>	Monthly Energy Consumption
<b>ML</b>	Main Line
<b>MOP</b>	Monthly Operating Period
<b>NBR</b>	National Building Regulation
<b>NFRC</b>	National Frame
<b>NHBRC</b>	National Home Building Regulation Council
<b>NL</b>	Node Line
<b>NREL</b>	National Renewable energy laboratory
<b>ODP</b>	Ozone Depletion Potential
<b>OMG</b>	Object Management Group
<b>PB</b>	Polybutane
<b>PE</b>	Polyethylene
<b>PP</b>	Polypropylene
<b>PVC</b>	Polyvinyl Chlorides
<b>R-VALUE</b>	Thermal Resistance Coefficient
<b>SABS</b>	South Africa Building Standard
<b>SANS</b>	South Africa National Standard
<b>SGW</b>	Solar Geyser system
<b>SHGC</b>	Solar Heat Gain Coefficient
<b>SHWS</b>	Solar Hot Water System
<b>SUNREL</b>	Hourly Building Energy Simulation Program
<b>SYSML</b>	System Modeling Language

<b>TRNSYS</b>	Transient System Simulation
<b>TV</b>	Television
<b>UML</b>	Unified Modeling Language
<b>U-VALUE</b>	Thermal Transmittance Coefficient
<b>VAV</b>	Variable Air Volume
<b>WR</b>	Wattage ratio
<b>YOP</b>	Yearly Operating Period
<b>YEC</b>	Yearly energy Consumed by each appliance

# CHAPTER ONE

## GENERALITY

### 1.1 Introduction

Today the world is facing serious problems, among others, global warming and climate change caused by greenhouse gas emission (GHG emission). This is the reason why developed countries organized meetings called the “Kyoto protocol” with the objective to reduce the GHG emission (Ziuku & Meyer, 2012). The congregation of Kyoto protocol declared that electrical energy consumption in both developed and developing countries is one of the major causes of GHG emission.

The increasing worldwide human population and the improving living standard of people, together with a high demand of comfort level, the energy consumption of residential buildings is increasing rapidly. As result, in South Africa, the power supply network is running out of balance between energy generation and demand. Furthermore, the South African electrical energy is responsible for GHG emission as well. The Kyoto protocol concerned South Africa as well (Rodney & Milford, 2009). South Africa has ratified the United Nations Framework Convention on Climate Change (UNFCCC) and its Kyoto protocol and plays a proactive role in the climate negotiations.

That is why South Africa is studying the potential strategies for possible mitigation of South Africa’s GHG emission. The target was to launch Long Term Mitigation Scenarios (LTMS) that would provide a formal analysis from which the South African government could shape a strong climate policy. With such a strong climate policy, South African negotiators would adhere to, and procure a position in the UNFCCC and its Kyoto protocol.

The Intergovernmental panel on climate change (IPCC) declared that the building sector plays an important role in the GHG emission. Energy is mainly consumed during the use of heating, cooling, ventilation, lighting, appliances, etc... (Milford, 2009). Energy Efficiency is one of the major emission reduction potentials identified in the LTMS. That is why energy efficiency is one of the core targets of South Africa’s climate Policy.

### 1.2 Statement of the problem

In South Africa, the inefficiency of energy consumption in building sectors does not only affect climate change, but the power supply networks as well. The poor efficiency of energy in building sectors is caused by:



a) Poor design and construction planning by the architect:

The poor design does not take in account solar orientation to enable natural ventilation and day light instead of using electrical devices.

b)The uncontrolled and untimely use of electrical appliances

Electrical devices are “on” when they are not needed (i.e. outdoor lights left “on” during the day, geysers are left on when there is no one at home, etc).

c) Bad insulation of building skin (wall, windows, doors, ceiling, floor etc...):

The bad insulation of building skins creates heat leakage during the heating process and solar heat infiltration during the cooling process.

d) The over sizing of HVAC systems:

In a study conducted by a utility company in Colorado,(Jones, 2001), it was found that the HVAC equipment was over-sized between 145% and 322%. The result is an overconsumption of energy.

e)The wrong choice of HVAC and Lighting systems:

Some buildings are using devices with poor efficiency (i.e. the use of incandescent lamp instead of CFL(s) or LED(S)

### **1.3 Hypotheses**

What do we need to rectify overconsumption problems?

- Set up an artificial control on the building?
- Make a good design for future buildings?
- Make sure that Building skins have tight thermal insulation?
- Calculate accurate heating and cooling loads that would help to size adequate HVAC systems.
- Select very efficient HVAC and lighting system

### **1.4 Research aim and objective**

The objective of this work is the development of an automated building energy model software tool with the new modeling language SysML, to model heating and cooling loads, to predict the energy performance, to enhance the energy efficiency and to forecast the yearly building energy consumption. This tool will serve as an energy modeling program to other users. The users will define the building through series of inputs.

So far several building energy models have been developed, but an ideal model has not yet been found because of the complexity of the system and the software tools used for modeling. SysML is capable of demystifying the system and to lead to successful models because of its flexibility, reliability and compatibility.

The targets of this work are to calculate heating and cooling loads accurately, to set up an artificial control system, to select efficiency HVAC and lighting systems and to calculate the yearly energy consumption in the building.

This energy model tool will be an excellent tool for energy efficiency. This may help in the LTMS to promote South Africa's climate change policy.

### **1.5 Delimitation**

This work is based on the residential building energy consumption of a building in South Africa in Western Cape more precisely in Stellenbosch. The building used as sample in this work, as well as our research, is consequently, in position, dependent due to influence through factors such as the climatic condition and weather in Stellenbosch area. The building will be related to the South African norms of residential building construction.

Furthermore it should be noted that our building is supplied with electrical energy for domestic applications according to South Africa National Standards (SANS) and code for energy supply for domestic applications category and IEC Standard.

### **1.6 Significance of the research**

This energy modeling software is a vital step in building energy modeling, since up to the present software energy modeling is very complex. As a result, they lead users to multiple errors and inaccurate results. In summary, such a model brings enormous benefits for:

- 1 Nature and humanity since energy consumption has become an alarming concern with regard to pollution and climate change.
- 2 The energy supplier (ESKOM), who recently implemented a campaign called "49m" to reduce energy consumption by the users as much as possible.
- 3 The occupants of the model building, since the user's energy consumption will be minimized.

## **CHAPTER TWO LITERATURE REVIEW**

### **2.1 Introduction**

Electrical energy is the main foundation of the innovation and perfection of actual technology, and it is generally a type of energy the most widely used. Electrical energy is in higher demand than any other type of energy, and it is indeed one of the major tools in all sectors and places, including residential areas.

Electrical energy is also the backbone of a country's economy, because it drives the all sectors of industries, from the medical sector to manufacturing of sport, educational and any industrial fields.

Therefore research in electrical engineering generally focuses on the perfection and the enhancement of flexibility and reliability of electricity generation, transmission, distribution, consumption and all related sub-categories of the field. Furthermore electrical energy is one of the main causes of GHG emission.

This research project focuses on energy consumption in a residential building. The analysis of the consumption of energy in this residential building will be taken as a basic for the development of a model for the perfection of energy in residential buildings.

### **2.2 Electrical energy**

#### **2.2.1 Definition of electrical energy**

According to (Simpson, 2003), "the electrical energy is from a motion of metal free electron on the peripheral layer of an atom when the electric charge is applied across length that metal". Electrical energy is not visible to the naked eye, but its effects reveal its existence in phenomena such as: electrical shock, the running of electrical motor or heat generation through electrical resistance.

Electrical energy results from transformation of different forms of energy, such as: mechanical energy, solar energy, thermal energy, chemical energy and so forth.

#### **2.2.2 Main cause of electrical energy consumption in the residential building**

The electrical energy is part and parcel of our life. The need and the demand for energy are increasing at breath taking speed all over the world (Merz et al., 2009). Because of its flexibility and other advantages amongst other, the electrical energy is generally the most used and the most consumed energy for domestic applications. Electrical energy transforms itself very easily into other forms of energy which are useful to humanity in all

areas despite some losses. In a residential building, for instance, electrical energy is very useful and indeed a prerequisite for many kinds of domestic applications, which make the residents' daily life more comfortable and more efficient. Domestic applications are divided in two categories, first category contains small and medium consumers of energy and the second category contains big consumers of energy that cause the over consumption of energy (Merz, et al., 2009),.

### **2.2.2.1 First category devices**

The first category groups appliances that occupants use for making life easy, comfortable and more pleasing according to their desires. Appliances are an integral part of every household, from a simple electric clock to the washing machine and hair dryer. They perform some household functions such as:

- 1) Cooking facilities (stove, microwave, toaster, kettle, frying pans coffee maker, blender, and so on
- 2) Entertainment (television, radio, tape recorder, TV games etc.)
- 3) Cleaning and ironing (vacuum cleaner, washing machine, dish washer etc.)
- 4) Cool drinks, water, and storing perishable foods (refrigerators, freezers)

### **2.2.2.2 Second category devices**

The second category groups the indoor environment control devices that perform the environmental quality, lighting, hot water system, transportation system and security system such as (lights, HVAC system, motorized gate, and elevator or escalator).

## **2.3 Lighting system**

The light is one of the biggest consumers of electrical energy in residential buildings. The light is very indispensable part of our lives, light is life. Most of information we receive about our surrounding is provided by our eyes. We live in a visual world (America, 1993).The most important sense organ in the human body is the eye, handling almost 80% of all incoming information. The light is the mainstay of eye and eyesight. Without the light, the visual perception will be virtually impossible. Insufficient light or darkness gives rise to a sense of insecurity and fear. Lack of eye sight loses vital bearing. Artificial light during the night, gives us a sense of security, makes our surrounding very comfortable, and we feel safe and it helps us to see the world around us.

We would like to briefly highlight the history of light. CIRCA 300000 years ago, man started to make fire as a source of warmth and light. The fire has enabled people to live in caves where the rays of the sun never penetrated (Simpson, 2003). An admirable

artwork in Altamira cave pushes back some 15,000 years, the use of artificial light. The light of campfires, oil and tallow lamps and light of kindling torches thoroughly has improved the standard of prehistoric man (licht.wissen, 2012).

Around 260 BC, Light has been used of outdoors applications. The Pharos of Alexandrian was built, in the city of Antioch, there were light in the streets. Aimé Argand is the one who has invented in 1783 the liquid- fuel lamps with a central burner. And thus some years later Dutchman Jan Pieter M. did the big improvement that could extract gas from coal for street lamps (Wissen, 2010).

The enormous event of electrical light came out in 1879, with Thomas A Edison's reinvention and technological application of the incandescent lamps invented 25 years earlier by the German Clock- maker Johann Heinrich Goebel (licht.wissen, 2012). Today we have an enormous expansion in lighting.

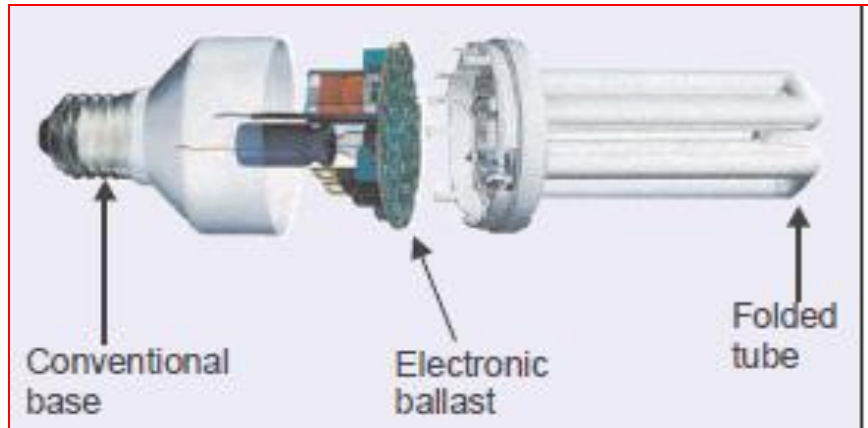
### **2.3.1 Different kind of electrical lamps**

The electrical light has passed through different stages from the incandescent lamps, over different forms, to fluorescent lamps; recently we have as outcome new devices at competitive, efficient and minimizing environment impact lights. Earlier, light has been used just for lighting, so in the present day; light is used for many utilities in different fields such as: aesthetic, entertainment, security services, in medicine for surgery, and so on. For that reason several kinds of appropriate light have been invented, to achieve their roles in their appropriate fields. Some of them are: laser lamp, arc lamps, X ray light, UV light, Infrared light, LED and so forth. Regarding our work, we will be focused only on light for lighting. Concerning lighting, there are several lamps that are used, in this work we will point out in detail some lamps, the most recently widely used for residential lighting.

#### **2.3.1.1 Incandescent lamp**

The incandescent lamp is a thermal radiator, generating light by resistance heating. This lamp consists of a filament mounted either in a vacuum, or in an inert gas, which does not chemically react with the filament (Simpson, 2003). Earlier the carbon was used as a filament in electric lamps; now the tungsten is used as the filament material, because it has a low vapour pressure and has a high melting point (Simpson, 2003). The light is generated by the flow of electric current through the tungsten filament and using the ( $I^2R$ ) heating effect to raise the filament temperature sufficiently to produce incandescent (Simpson, 2003). In addition to the incandescent lamp you have the main electric light

source. But this presents more weaknesses such as: poor luminous, low efficiency, short cycle of life and luminous flux is influenced by the level of the supply voltage.



**Figure 2.1 Construction of a compact fluorescent lamp (Simpson, 2003)**

### 2.3.1.2 Fluorescent Lamp (FL)

The fluorescent lamp is the most familiar of the large class lamp referred to as discharge lamp. In these lamps, light is created by an electrical discharge within a gas or vapour. The fluorescent lamps are produced in different forms. Among these form, we have: circular and U shaped lamps, miniature fluorescent lamps (Figure2.2), straight tubular lamps and so forth.

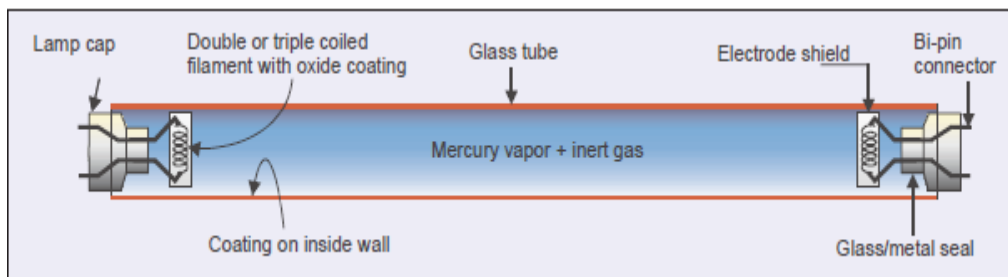


**Figure2.2 Fluorescent lamps circular and U shaped lamp (Simpson, 2003)**

In the family of fluorescent lamps, the straight tubular lamp is the most commonly used. They are produced in different lengths. And their lengths, thicknesses and diameters are standardized according to nominal power. For the straight tubular; the electrodes are placed at each end of the tube (Figure 2.3). In alternating current circuit, there is an alternation between the cathode and anode from each electrode. The electrode that

emits electrons is named as cathodes. There are two types of cathodes, the hot cathodes and the cold cathodes. For the normal hot cathode fluorescent lamp, each electrode is a tungsten filament of special construction created with Alkaline Earth Oxides. When the temperature rises to 1, 1000 Celsius, the cathode emits copious electrons. An anode can attract these electrons creating a current between an anode and cathode, (Alex, 1998), with gas filling the tube. This gas is compounded with the mercury vapour with the addition of Argon or a mixture of inert gas to excite the initial discharge.

When the fluorescent lamp is supplied by AC current, connected to either end, an arc is produced along the length of the tube, and the mercury vapour ionizes. There is an electromagnetic radiation produced by the combination of the ionization and excitation of the mercury atoms. The fluorescence is the light emitted while the radiation is present, phosphorescence is the light which continues to be emitted after the radiation removed (Simpson, 2003).



**Figure 2.3 the standard fluorescent lamp (Simpson, 2003)**

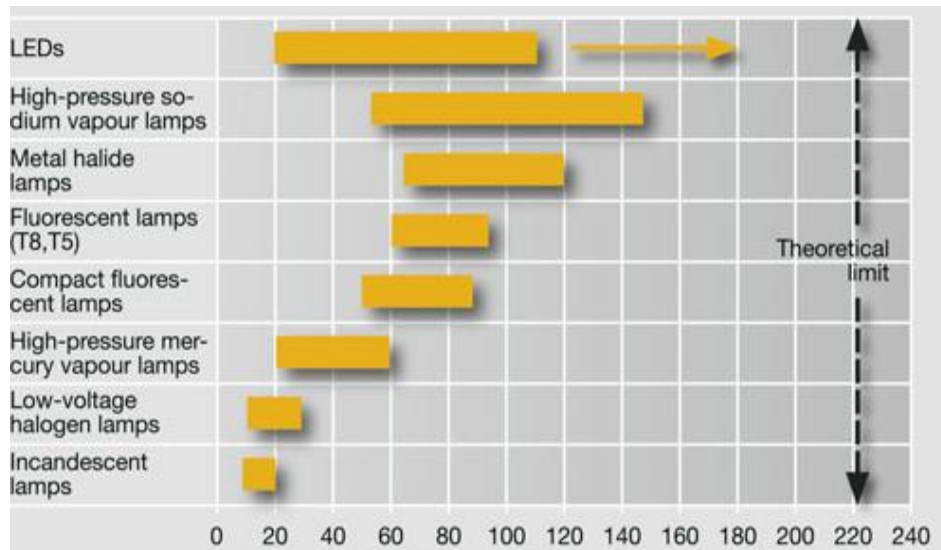
### **2.3.1.3 Compact Fluorescent Lamps (CFL)**

The CFL has the same characteristics as FL. The CFL lamps were introduced with idea of replacing General Lighting Service lamps (GLS). The CFL are much more efficient compared to incandescent lamps and they have a long life cycle. Figure 2.1 shows the construction of CFL.

### **2.3.1.4 Lamp Emitted Diode (LED)**

In an LED, a solid state crystal is indeed to emit light by passing an electric current through it. The type of crystals used has two sections or regions with a surplus of electrons (n-type semiconductor) and a sector with a deficit of electrons (p-type

semiconductor). When a direct voltage is applied, electrons flow across the junction between the two regions producing light in the process. The white LEDs can be created by additive color mixing or by luminescence conversion (licht.wissen, 2012). LEDs are probably the most cost effective energy saving products compared to other lights that is why it is called the light of the future (Figure 2.4). LEDs are tiny and extremely efficient; they are revolutionizing the world of light. They are the light of the future and they are conquering the realm of general lighting (licht.wissen, 2012).



**Figure 2.4 Efficiency of light sources lumen/watt excluding ballast losses (Wissen, 2010)**

### 2.3.2 Light measurement system

Light is a kind of energy. Light is nature's way of transmission in through the vacuum. Light moves very rapidly and does not have a fixed velocity. In a wide space, the speed of light is 300,000 Km per second or 186,382 miles per second. In the same way that we need objective methods of measuring electrical quantities, there is a need for the objective measurement of light (Simpson, 2003). Different techniques are applied to measure light. In fact the measurement can still be based on the MKS system, but it is necessary to introduce one or more fundamental unit, and the SI system uses the Candela as its unit of measurement (Simpson, 2003).

Light is a physical phenomenon. According to the physics experiments over the past 100 years, light has a dual nature. Isaac Newton proposed that light exist as a corpuscles (Simpson, 2003), with unit of energy (quanta), and is flashed in a straight line from its source. And Christian Huygens, suggest that light must have a wave nature (Simpson,



2003), and moves in a similar way with sound. Today the properties of light are based on both concepts. Light is a visible part of electromagnetic radiation, which made up of oscillating quanta of energy (licht.wissen, 2012). (licht.wissen, 2012), mention that light is a portion of the various electromagnetic, flying through space. This declaration of James Chark Maxwell, that light is a form of electromagnetic radiation, boost up to wave theory, and the problem of the other disappeared. On the other side Einstein, Planck and others demonstrated the photo –electric effect, where the light hits on certain substances could produce an electric current to run, so that the light is definitely energy. (Simpson, 2003), declares that, new version was proposed as the quantum theory of radiation, because it requires that energy only travels as a quantum of light. Today the physics put together theories, the wave and the quantum. The magnitude of the wave increases when its fronts overlap in phase with each other. When the wave’s fronts are out of phase, however, they cancel each other.

The length of the wave is given by:

$$wl = \frac{h}{mu} \tag{2.1}$$

Where:  $wl$  is the wave length,  $h$  is Planck’s constant ( $6626/ 10^{-34}$ joule second),  $m$  is the mass of the particle and  $u$  is the velocity.

(Simpson, 2003), points out that when an electron moves from a high level to the lower one, a photo is emitted, and that the same quantum of energy could be absorbed when an electron jumps from a lower orbit to a higher one.

The energy of photo is defined as:

$$E_1 - E_2 = hv \tag{2.2}$$

Where:  $E_1$  is the energy associated with the normal orbit,  $E_2$  is the energy associated with the excited orbit,  $H$  is the Planks constant and  $V$  is the frequency of the radiation emitted as the electron moves from level 2 to level 1.

The equation demonstrated by Planck for each photon which carrying energy is given as:

$$Q = \frac{hc}{wl} \tag{2.3}$$

Where:  $Q$  denotes the photon,  $h$  denotes the Planck constant  $c$  is the speed, and  $wl$  is the wave length.

Light measurement has been performed to verify the light installation design, to enable the good choice of light and to facilitate the set-up of lighting that can be reliable to application.

The luminance or photometric brightness is the measure of the amount of light emitted from a surface in a particular direction (convulse). (licht.wissen, 2012) Revealed that the Luminance indicate the brightness of an illuminated or luminous surface as perceived by the human. The unit of Luminance is Candela per square meter (Cd/m<sup>2</sup>). And (licht.wissen, 2012) developed the mathematical expression as:

$$L = P_{ref} \cdot \frac{E_{ill}}{\pi} \quad (2.4)$$

Where: L is the luminance, P<sub>ref</sub> is the reflectance and E<sub>ill</sub> is the illuminance.

$$n = E_{ill} \frac{A_r}{Z \Phi \eta_b WF} \quad (2.5)$$

Where: n is the number of luminaires, A<sub>r</sub> is the area of room, Z is the number of lamps per luminaire, Φ is the luminance flux of a lamp, η<sub>b</sub> is the light output ratio, and WF is the maintenance factor.

### 2.3.2.1 Behaviour of light

Nonetheless there are aspects of the behaviour of light which are of importance in lighting control, and for which it is useful to have a basic understanding (Simpson, 2003).

#### ➤ Reflection

The light obeys to the law of reflection or specula reflection. Light reflecting off of a polished or mirrored surface and respond to the law of reflection. The Angle of incidence is equal to the Angle of reflection (Ryer, 1998). The specula reflectance depends with the material. On the normal sheet of glass, the specula reflectance is from 7% and can send out most light to 95% for a surface aluminized mirror. And the reflectance of polished stainless steel and chromium plate play around 60% the rough surface and the matt white painted surface are the main cause of diffuse reflection.

#### ➤ Refraction

The refraction Snell's law (Ryer, 1998), when the light goes between dissimilar objects, the rays bend and change the speed slightly.

Snell's refraction law is expressed by:

$$n \sin(\theta) = n' \sin(\theta') \quad (2.6)$$

This equation depends on two factors: the incident angle, and the refractive index.

(Simpson, 2003), explains that refraction expresses what goes on when the light goes from one transparent medium to another, and expresses the refractive index (μ) by:

$$\mu = \frac{\sin i}{\sin r} \quad (2.7)$$

Where:  $\sin i$  is the angle of incidence and  $\sin r$  is the angle of refraction

➤ Diffraction

The diffraction is a kind of wave phenomenon which is dependent on wavelength (Ryer, 1998), and it is expressed by:

$$\theta = \frac{wl}{D} \quad (2.8)$$

Where:  $\theta$  is the diffraction angle,  $wl$  is the wavelength of radiant energy and  $D$  is the aperture diameter.

A diffraction established uses the interference of wave created by diffraction to take apart light angularly by wave length (Ryer, 1998).

### 2.3.3 Tubular day lighting

Tubular day lighting systems are the technique used by means of some devices to collect daylight from outside and transmitting it into the heart of the building (Callow & Nottingham, 2003).

Today with the advanced technology, the dual nature of light (wave form and quantum) and the properties of the light (reflection, refraction, diffraction and other properties), it is possible to provide in the building, adequate, reliable and efficient light from day lighting. Tubular day lighting systems are made up of the following four basic components: polycarbonate clear dome, aluminium roof flashing, high-reflective light transfer tube with adjustable option, and domed diffuser or troffer with flat or pyramidal lens. Other parts are available such as curb and cap options, troffer and dimmers. The reliability, efficiency and the performance of tubular day lighting systems are related directly to the availability of the sunshine and skylight, and indirectly to an area's climatic conditions.

That is why geographic area and weather data are the hinge parameters during the process of tubular day lighting system's installation. Because of the availability of the sun and skylight, these systems are adequate to the building in use during the day such as: shops, workshops, schools, offices on forth. Tubular day lighting systems may be used in the residential building as an auxiliary lighting system.

The geographic area and climatic parameters of South Africa are very compatible to Tubular day lighting systems. (Manyuchi, 2008)(Hordeski, 2001) Solar levels in South Africa are amongst the highest in the world. The average daily solar radiation varies between 4.5 and 7kWh/m<sup>2</sup>, even in winter, and some parts of the country receive more than 6 kWh/m<sup>2</sup> per day. Therefore tubular day lighting systems will contribute a lot to

energy efficiency and renewable energy. Setting up such a system in South Africa, will be more profitable, because huge portion of energy consumed by lighting systems will be saved by tubular day lighting system.

That is the global overview of lighting system that we have wanted to explain, the following point we explained about heating ventilating and air conditioning system (HVAC system).

## **2.4 Heating ventilation and air condition System (HVAC system)**

Human beings live in a hostile environment accordingly to the weather, season of the year and geographical locality. To make the environment comfortable, several kinds of Heating Ventilating Air Conditioning (HVAC) equipment has been invented (Hordeski, 2001) .

### **2.4.1 Definition of Air conditioning**

The air conditioner primarily provides and maintains an artificial and comfortable environment for the occupants within a building or an enclosed premise. The comfort parameters are generally temperature, humidity, and air motion.

Heating Ventilating Air Conditioning Systems comprise a large use of energy in today's buildings (Jones, 2001) and (Engineers, 2000). It is estimated HVAC System consume about 35% of the total energy used in buildings (Kharagpur, 2008) and (ASHRAE, 2014).

### **2.4.2 Aims of Air conditioning**

(Engineers, 2000), the aims of air conditioning system are to produce an environment which is comfortable to the majority of the occupants in the building such as: circulate the air to dilute the CO<sub>2</sub> level and meet the oxygen needs of the occupants, the dilution of the odours present to a socially acceptable level, the minimizing the increase in air temperature in the presence of excessive sensible heat gain and the control the humidity to limit condensation.

### **2.4.3 HVAC Principle of functioning**

The HVAC system functioning is based on thermodynamic principles and laws which deal with the relations among heat, work and properties of system (temperature, Pressure and Volume) which are in equilibrium. The HVAC system deals with heat and mass transfer, fluid mechanic, expansion of gases and quantity of motion. Refrigeration and HVAC system both are working on thermodynamic cycle that is categorized into gas cycles and vapour cycles (Kharagpur, 2008) (Rona, 2004).

Vapour cycles can be subdivided into vapour compression system, vapour absorption system, vapour jet system, and so on.

Vapour Compression systems and Vapour absorption refrigeration systems are the most commonly used in refrigeration and HVAC systems. The HVAC system can work in close loop and in open loop that means the system is in contact with the atmosphere.

#### 2.4.3.1 Heat transfer

Generally heat transfer takes place in three different modes: conduction, convection and radiation (Winterbone & Turan, 1996).

- Conduction: when the transfer occurs through a substance without any motion of the substance, then mode of heat transfer is called conduction” according to (Ahmadul Ameen, 2006), and that is given by:
- Convection: according to (Ahmadul Ameen, 2006), If it transfer through a substance due to the movement of the substance, then it is called convection heat transfer.
- Radiation : heat transfer through radiation is a form of electromagnetic waves, or is the thermal radiation emitted by a body.

#### 2.4.3.2 Fluid mechanic

The flow of gas is part of fluid mechanic based on three law fundamentals.

- Conservation of mass of fluid

The mass of a motion fluid is the same at every point and the formula is stated as follows:

$$m_1 = \rho_1 A_1 v_1 = \rho_2 A_2 v_2 = m_2 = m \quad (2.9)$$

And that imply:

$$v_1 = A_2 v_2 \quad (2.10)$$

Where:  $A$  is the section of the pipe in which the fluid flows,  $m$  is the mass of the fluid,  $\rho$  is the density and  $v$  is the velocity of the flowing fluid.

#### 2.4.4 Type of HVACs

There are several types of electrical HVAC systems; we can enumerate some of them by giving their strengths and weaknesses (Rishel et al., 2006):

### 2.4.4.1 Self-contained wall or window unit

It is a small air conditioner (Figure 2.5), it is called self-contained because indoor and outdoor parts are fitted together in the same casing. Being in one casing, this air conditioner must be mounted or be fixed on the external wall or window with the evaporator inside the room and condenser outside the room.

Advantages:

- ❖ Low cost
- ❖ Flexible
- ❖ Simple

Disadvantages:

- ❖ Short life
- ❖ Noise
- ❖ Poor control
- ❖ Poor filtration and air distribution
- ❖ Lack fresh air supply
- ❖ Unsightly

Applications:

- ❖ Small building
- ❖ Individual rooms

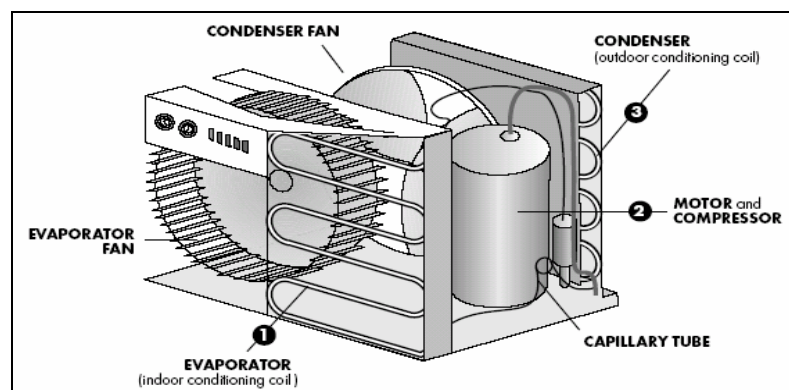


Figure 2.5: Self-contained wall or window unit (Kharagpur, 2008)

### 2.4.4.2 Split direct expansion (DX) unit

The DX unit is composed of two blocks or units, outdoor units air cooled (condenser unit) and indoor unit (fan, coil unit). The compressor can be either part, but is often on the outdoor units. There are two sort of split air conditioner. Split type unit ducted one indoor unit fixed in the ceiling; this system is using ducts to cool the areas. The second one is split type unit cassette, on this one the indoor unit is fixed in the ceiling and cooling takes place through the grille.

Advantages:

- ❖ Indoor unit need not be on outside wall
- ❖ Indoor unit can be fixed to the ceiling
- ❖ Silencers can be used for indoor units
- ❖ The control is improved with multiple refrigerant circuits

Disadvantages:

- ❖ Restriction on length of refrigerant piping between indoor and outdoor unit.
- ❖ Fresh air supply is limited due to the different levels between indoor and outdoor units

Applications:

- ❖ Small shop
- ❖ Computer rooms
- ❖ Individual area.

#### **2.4.4.3 Split system reversible heat pump**

The split system direct expansion, this system uses valves to change the function of condensing and evaporating coils to be reversed. This type of split air conditioned has the same advantage, disadvantages and applications as Split direct expansion (DX) unit described above.

#### **2.4.4.4 Water cooled unit**

This is a self-contained indoor unit consisting of evaporator, compressor, cooled condenser with separate outdoor cooling tower.

Advantages:

- ❖ Flexibility in location for outdoor and indoor units.
- ❖ Better to control the air cooled units.

Disadvantages:

- ❖ Maintenance of cooling water circuit is required.

- ❖ Cooling water treatment advisable.

Applications:

- ❖ Small zone
- ❖ Computer room

#### **2.4.4.5 Glycol cooled unit.**

This type of HVAC is a self-contained indoor unit that consists of evaporator, compressor and glycol cooled condenser with remote and air heat exchanger. This unit uses glycol water instead of water. The glycol water mixture is used in this system to prevent freezing.

Advantages:

- ❖ No water in the system
- ❖ No freezing problem

Disadvantages:

- ❖ Need to control if the glycol is still in the system.

Applications:

- ❖ Computer rooms

#### **2.4.4.6 Fan coil units**

Fan coil units is used for one or more areas, the system makes running chilled or hot water from the central unit to individual units in room or zone which is cooled or heated.

There are two sorts of fan coil units

- Two pipe system: in this system one pair of pipes are used for chilled water in the summer season and the other one used for hot water in the winter season. This unit is good for continental climate and not good for temperate climate.
- Four pipes system: in this system, pipes for chilled water are separated from the pipe for hot water. Although this unit is more expensive compared to the two pipe system it is more flexible and more controllable. Some rooms can be cooled while others are heated.

Advantages:

- ❖ Flexible
- ❖ Straight forward design



- ❖ Good control

Disadvantages:

- ❖ High cost

Applications:

- ❖ Office, hotel bedrooms, luxury housing, schools

#### **2.4.4.7 Heat recovery unit**

The Heat recovery unit HVAC system is a self-contained refrigeration and heat pump, room units reject heat to water circulating throughout building when cooling and taking the heat from the water when heating. When the system is working as a cooler the heat is rejected by the unit and when the system is working as a heater, the heat is supplied by the unit.

Advantages:

- ❖ Energy conservation
- ❖ Particularity in temperature climates

Disadvantages:

- ❖ Unit is larger than fan coil units

Applications:

- ❖ Office
- ❖ school

#### **2.4.4.8 Induction system**

This system is a central air plant; it delivers conditioned air through high-velocity ducting to induction unit in the room. Water from a central plant is also supplied to the induction units. The air conditioned or primary air supplied to the unit induces room, or secondary air through the unit. This induced secondary air passes over the water coil and thus heated and cooled.

- Two pipes changeover system: one pair of pipes used for chilled water in summer and one for hot water in winter. Not suitable for temperate climate.
- Two pipes non changeover system: one pair of pipes for chilled water only, with heating by primary air only.
- Four pipes system: separate pair of pipes for chilled water and hot water. Lower running cost and better control than two pipes no changeover system.

Advantages:

- ❖ Space saving through use of high velocity and small diameter
- ❖ Individual room control
- ❖ Very suitable for modular building layout
- ❖ Central air plant need handling only part of air treated.
- ❖ Particularly applicable to perimeter zones of large buildings
- ❖ Suitable for large heat loads with small air volumes.

Disadvantages:

- ❖ High investment cost
- ❖ Installation and operation are all more complex than fan coil system
- ❖ Individual units cannot be turned off

Applications:

- ❖ Offices
- ❖ Schools
- ❖ hospital

#### **2.4.4.9 All air Constant Volume reheat system**

For this system, central or local plant with cooler sized for latent heat cooling load and reheater to balance for sensible heat load and for winter heating. Reheated can be remote from cooler, several reheaters can be used with one cooler to give a degree of local control. The humidifier can be incorporated with preheater to give complete control of discharge air temperature and humidity.

Advantages:

- ❖ Simple
- ❖ Free cooling available for low outdoor temperatures
- ❖ Several reheat zones can be used to improve control
- ❖ Good air distribution possible because diffusers handles constant volumes.
- ❖ Independent control of volume

Disadvantages:

- ❖ Waste of energy by reheating
- ❖ Expensive in both investment and running cost
- ❖ Large volumes of air to be treated in central plant.
- ❖ Recirculation system necessary

Applications:

- ❖ Industrial
- ❖ Houses
- ❖ Apartments
- ❖ Shopping mall
- ❖ cinemas

#### **2.4.4.10 Duel duct system**

In dual duct system, a central plant delivers two streams of air through two sets of ducting to mixing boxes in the various rooms. The two streams are at different temperatures.

Advantages:

- ❖ Cooling and heating available simultaneously
- ❖ Free cooling available at low outdoor temperature
- ❖ Individual room central zoning not necessary
- ❖ Flexible operations

Disadvantages:

- ❖ Use more space for two sections of supply air ducting
- ❖ More air has to be treated in the central plant
- ❖ Recirculation system is necessary
- ❖ Expensive in both capital and running cost

Applications:

- ❖ Hospitals
- ❖ Publics rooms
- ❖ Schools
- ❖ Hotels

#### **2.4.4.11 High velocity air system**

Similar to all system but operate with high air velocities in supply ducts. Outlet boxes incorporate sound attenuations. And recirculation system is usually at low velocity

- Single duct: this unit saves space and zone central can be used. This system requires large volume of air to be treated in central plant. This system also requires high fan pressure and fan power.

- Dual ducts: similar to low velocity dual duct but with sound attenuation incorporated in outlet boxes, this unit is very flexible in operation compared to the single duct and can handle larger air volumes than single duct.

#### **2.4.4.12 Variable Air Volume system (VAV)**

An all air system in which local control is obtained by varying volume discharged at each diffuser or group of diffusers in response to the dictates of a local thermostat. Capacity of the supply and extract fan is reduced as total system variable requirement and part loads. The fan is controlled by: variable speed, variable blade pitch, variable inlet guide vanes, and disc throttle on fan outlet. Figure 2.6 depicts the overview of VAV system.

Advantages:

- ❖ Efficient part load operations.
- ❖ Individual room or area control.
- ❖ Unoccupied area must be closed off with damper.

Disadvantages:

- ❖ Special provision needed for heating.
- ❖ Extra central needed to maintain minimum fresh air.
- ❖ Complexity of control.
- ❖ Cannot provide full control of humidity.
- ❖ Expensive investment cost.

Applications:

- ❖ Hospitals
- ❖ Hotels
- ❖ Schools
- ❖ Small shops

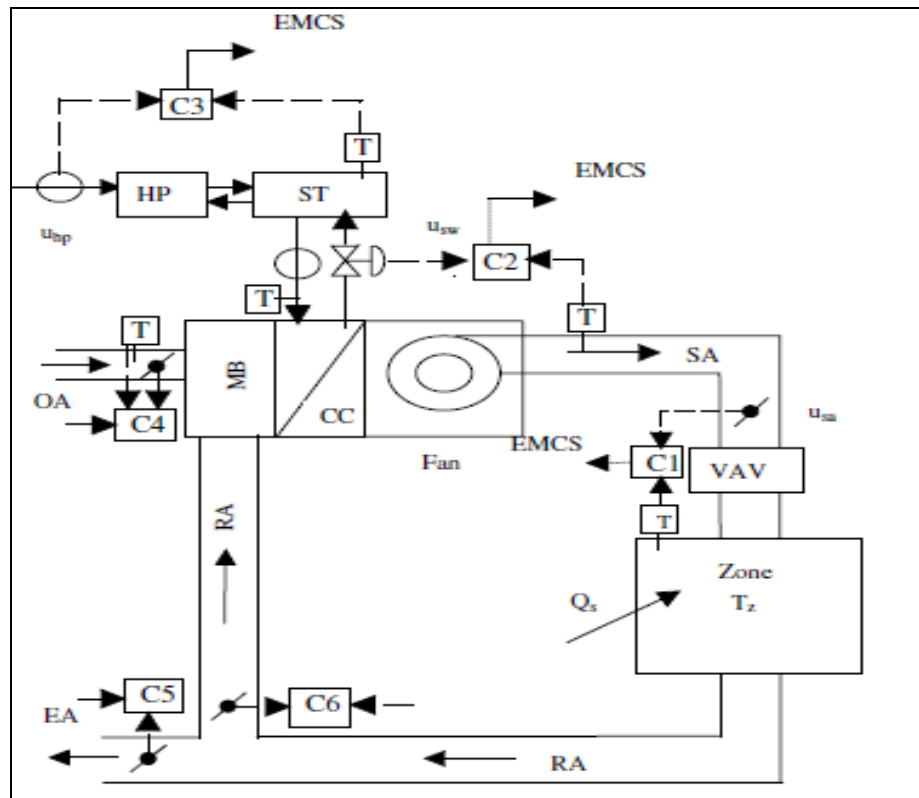


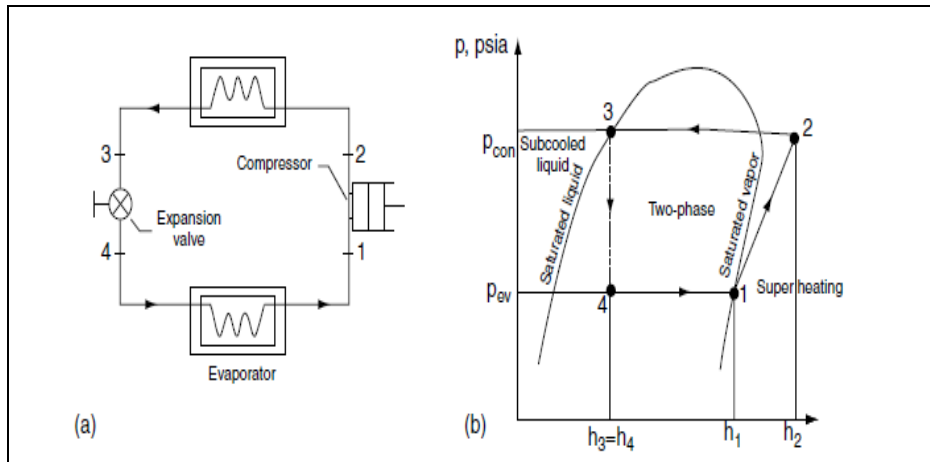
Figure 2.6 Overview of Variable Air Volume system (Honeywell, 1997)

## 2.4.5 Heat pump

For the HVACs system, the heat pump presents more advantages compared to other HVACs enumerated above. The heat pump is a device that takes heat from one zone (lowest temperature) called the source to another zone (highest temperature) called sink. The heat pump operation is based on vapour compressor refrigeration system with reversing valve (Rona, 2004). The reversing valve enables reversibility of refrigeration flow. Once the cycle of refrigerant is reversed automatically the condenser and evaporator roles will be switched. Then the system can heat and cool when needed.

### 2.4.5.1 Heat pump components basic components

The heat pump is a closed loop in which the refrigerant flows through the main components such; compressor, evaporator, condenser and expansion valve.



**Figure 2.7 Overview of the vapour compression refrigeration system and P, Psia diagram**

➤ Condenser

The condenser, is often called the heat exchanger, cools the pressurized gas until it condenses into high pressure, moderate liquid (Guptan, 2003). (IIT KHARAGPUR 2008), Condenser and evaporator are basically heat exchangers in which the refrigerant undergoes a phase change (Figure 4.7). Next to the compressor the proper design and selection of condenser and evaporator is very important for satisfactory performance for any refrigeration system.

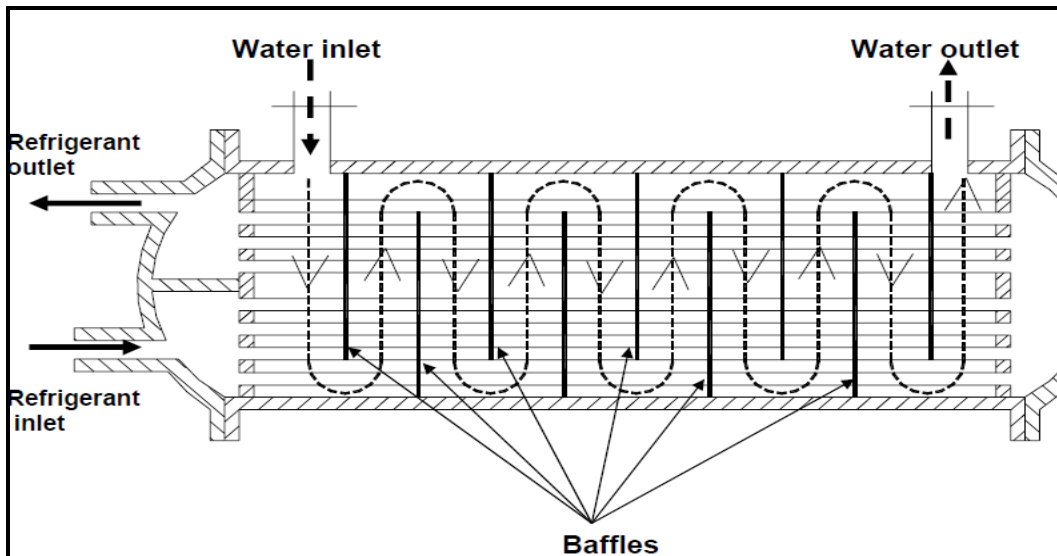
➤ Evaporator

An evaporator is an element in which the gas vaporizes itself and takes a quantity of heat from the worm zone. According to (IIT KHARAGPUR 2008) the evaporator, like a condenser, is a heat exchanger. In an evaporator the refrigerant boils or evaporates and in doing so absorb heat from the substance being refrigerated. (commission, 2013), the evaporator moves heat from the air inside a building using coil. The evaporator comprises tubing and shell where liquid and gases pass the mass flows rate in the evaporator tube.

Concerning the liquid flowing in the shell is given by:

$$Nu = \frac{h_d}{k_f} = C R_{\epsilon d}^{0.5} \epsilon P_r^{0.3} \left[ \frac{\mu}{\mu_w} \right]^{0.4} \quad (2.11)$$

Normally evaporators are designed to operate in nucleate pool boiling regime as the heat transfer coefficient obtained in the regime are stable and are very high. Various studies show that in nucleate pool boiling region, the heat transfer coefficient is proportional to the 2 or 3 power of temperature difference between the surface and the boiling fluid, i.e.



**Figure 2.8 Schematic of a flooded type and shell-and-tube evaporator (Kharagpur, 2008)**

➤ Expansion device

An expansion device is another basic component of a refrigeration system with basic functions such as:

- ❖ Reduce pressure from condenser pressure to evaporator pressure
- ❖ Regulate the refrigerant flow from the high pressure liquid line to evaporator.

There are several types of expansion devices, concerning our window air conditioner, the capillary tube are used in packaged air conditioner.

The functioning of capillary tube is based on fluid mechanic (mass, energy and pressure conservation). (Ahmadul, 2006) explains, in the capillary tube, the pressure drops because of the friction and acceleration of the refrigerant through the narrow passage.

The equations demonstrated below, have been developed to express mathematically the mass and momentum conservations.

- Mass conservation:

$$\rho v A + \frac{\partial(\rho v)}{\partial y} \Delta y A - \rho v A = 0 \quad (2.12)$$

Momentum conservation:

$$\mu R^2 \left[ \varphi v v + \varphi v \frac{\partial v}{\partial y} \Delta y \right] - \pi R^2 [\varphi v v] = -\pi R^2 \frac{\partial P}{\partial y} \Delta y - \rho a v g \pi R^2 \Delta y - 2\pi R \Delta y Z_w \quad (2.13)$$

At the face  $y+\Delta y$ , *Taylor* series expansion has been used for pressure and momentum and only the first order terms have been retained, and we obtain:

$$\varphi v \frac{\partial v}{\partial y} = -\frac{\partial P}{\partial y} 2 \frac{\tau_w}{R} \quad (2.14)$$

According to (Kharagpur, 2008) in the fluid flow through pipes the pressure decreases due to shear stress. This will be referred to as frictional pressure drop and a subscript “f” will be used with it, and it will be written in terms of friction factor. And the frictional pressure drop  $\Delta P_f$  may be obtained from the following equation:

$$\tau_w = \frac{R \Delta P_f}{2 \Delta y} \quad (2.15)$$

The friction factor is defined as:

$$\Delta P_f = \varphi f \frac{\Delta y v^2}{D} \quad (2.16)$$

The mass velocity is expressed by:

$$G = \rho v \quad (2.17)$$

And we have mass flow is expressed as follows:

$$m = [\pi D^2 / 4] \rho v \quad (2.18)$$

- Reversing valve

This device allows the flow of the refrigerant to be switched and ultimately determining where it is going to heat or cool a system

- Refrigerant

The refrigerant is the fluid used for energy exchanges in a refrigeration system or heat pump system (Janis & Tao, 2005). The refrigerant transport heat from the source to the sink (Quiston, et al., 2005) the refrigerant usually absorb heat while undergoing a phase change in the evaporator and the refrigerant is compressed to higher pressure and higher temperature, allowing it to transfer that energy in the condenser directly or



indirectly to the atmosphere. The selection of refrigerant is based on many factors and properties such as; thermodynamic characteristics (high latent enthalpy of vaporization, low freezing temperature, positive evaporating pressure), physical and chemical characteristics (high dielectric straight of vapour, good heat transfer characteristic satisfactory oil solubility and viscosity), and environment friendly (Ozone Depletion Potential and Global warming Potential).

In the HVAC system refrigerant, there are four classes of elements or compounds: Halocarbon, Hydrocarbon, Organic and Inorganic (Hordeski, 2001). The halocarbon is called the popular classes of refrigerant because they were been used since for half a century were introduced by Du Pont Company with trade name "Freon".

There are also several groups of refrigerant such as:

- ❖ Chlorofluorocarbon (CFC), these include R11, R12, R113 and R115, this group contain Chlorine that have high ODP. For that reason in 1995, the USA has banned the production of CFC and refrigerating devises using this refrigerant.
- ❖ Hydro fluorocarbon (HCFC) is another group that regroup R22, R123, R124, R 141a, R141b, these refrigerants contain also Chlorine, yet with the presence of Hydrogen, the ODP becomes weak. In 2004, the USA has restricted the production of this refrigerant.
- ❖ Hydro fluorocarbon; with R125, R 134 and R152a, this group does not contain Chlorine, and is friendly to ODP on the other hand with high (GHP).
- Compressor

A compressor is the most important and often the more expensive component. The function of a compressor in a vapour compression refrigeration system, its function is to continuously draw the refrigerant vapour from the evaporator so that a low pressure and a low temperature can be maintained in the evaporator at the level that the refrigerant can boil by extracting heat from the refrigerated space. The compressor then has to raise the pressure of the refrigeration level at which it can condense by rejecting the cooling medium in the condenser, declared (Kharagpur, 2008)

There are several types of compressors used in refrigeration and HVAC system, These compressors are classified in several ways; based on the working principle such as; positive displacement type, rotor-dynamic type, reciprocating type, rotary type, orbital type, acoustic compressor, radial and axial compressors. Based on arrangement of

compressor motor or external drive such as; hermetic or sealed compressor, open type, and semi-hermetic (semi-sealed) type.

❖ Reciprocating compressor

(Jones, 2005) explains that, the reciprocating compressor is the workhorse of the refrigeration and HVAC industry, The reciprocating compressor is the most widely used compressor with coding capacities ranging from a few watt to hundreds of Kilowatt with high speed 3000 to 3600 rpm.

The reciprocating compressor consist of a cylinder with a piston moving up and down or back and forward, with suction and discharge valves to reach suction and compression cycle of the refrigerant vapour (Figure 4.13). The inlet side of the compressor is connected to out of the evaporator in t mean time the outlet of the compressor is connected to condenser inlet. The pressure difference between the cylinders and the inlet or outlet manifold respectively lead the opening and the closing of the suction and the discharge valves. (Kharagpur, 2008), the inlet pressure is equal to or slightly less to the evaporator. Similarly the pressure in the outlet manifold is equal to or slightly greater than the condenser pressure.

The performance of the reciprocating compressor is based on the mass flow rate ( $m$ ), the power consumption of the compressor ( $W_c$ ), the temperature of the refrigerant at compression exit ( $T_c$ ) and the performance under part load conditions.

For reciprocating compressor, the ratio of volumetric flow rate of refrigerant ( $\eta_v$ ) is given by:

$$\eta_v = \frac{mV_s}{V_{sw}} \quad (2.19)$$

Where:  $m$  and  $V$  are the mass flow rate of refrigerant (Kg/s) and compressor displacement rate ( $m^3/s$ ) respectively, and  $v$  is the specific volume ( $m^3/kg$ ) of the refrigerant at the compressor inlet.

The power input is given by:

$$W_c = mW_{id} = \frac{V_{sw}}{v_s} \int_{P_s}^{P_c} V dP \quad (2.20)$$

For the isentropic process  $Pv^k = \text{constant}$ , hence the specific work ( $W_{id}$ ) of compressor can be obtained by integration, and it can be shown to be equal to:

$$W_{id} = \int_{P_e}^{P_c} V dP \left( \frac{K}{K-1} \right) \left[ \left( \frac{P_c}{P_e} \right)^{\frac{K}{K-1}} - 1 \right] \quad (2.21)$$

In the above equation,  $k$  is the index of isentropic compression. The approximate volume of it can be obtained from the value of the pressure and the specific volume at the suction and discharge state as

$$k \approx \frac{\ln(P_c/P_e)}{\ln(V_e/V_c)} \quad (2.22)$$

The work of compression for the ideal compressor can also be obtained by applying energy balance across the compressor:

$$W_{id} = \frac{W}{m} = (h_c - h_e) \quad (2.23)$$

The above equation can also be obtained by the thermodynamic relations:

$$T_{ds} = dh - v dP \Rightarrow dh = V dP \quad (2.24)$$

$$W_{id} = \int_{P_e}^{P_c} V dP = \int_{P_e}^{P_c} dh = (h_d - h_c) \quad (2.25)$$

The above expression is valid only for reversible, adiabatic compression.

#### 2.4.5.2 Auxiliary components (air handling)

##### ➤ Fan

The fan is one of the crucial devices in the HVAC system. The fan keeps air moving in the space through the duct. (Janis & Tao, 2005), A fan is a mechanical device that moves air used in the HVAC system to ventilate or to transport heat or cooling.

All fans consist of rotating impeller blade these can be forward-curved, backward curves or radial. For the HVAC system, the fan is mounted in the enclosure unit called housing. Generally the fan is driven by an electrical motor or an engine. In the HVAC system, the fan is often driven by an electrical motor (Janis & Tao, 2005). The fan and the motor can be fixed in the same unit or can be fixed separately externally. The coupling between motor and fan wheels can be direct (direct-drive) or can be coupled by belt and pulleys called sheaves. (Janis & Tao, 2005), in direct-drive, the fan runs at the same speed with the motor in a non-adjustable way. The sheaves and the belt control the speed and the performance of a fan or function of capacity is represented by graphs and showing the pressure, efficiency and power (Quiston, et al., 2005).

According to (Janis & Tao, 2005), The performance of the fan is measured by the following characteristics: volume of air supplied per unit time or capacity normally

in(cfm), pressure or system pressure at the design point normally in( psi), power input, horsepower(HP),mechanical and static efficient in percentage, and others factors such as; acoustic, efficiency, relative cost and physical size.

(Quiston, et al., 2005) states that there are several simple relations between fan capacity, pressure, speed, and power, which are referred to as the fan laws.

The first fan laws are the most useful and are given as: the capacity is directly proportional to the fan speed, the pressure (static, total, or velocity) is proportional to the square of the fan speed, the power required is proportional to the cube of the fan speed,

The second law is defined as: the pressure and the power are proportional to the density of the air at constant speed and capacity, the speed capacity and the power are inversely proportional to the square root of the density and the pressure constant

(Janis & Tao, 2005), reveal some formulas these have been developed to determine air flow rate, pressure required and fan power:

$$TP = SP + VP \quad (2.26)$$

Where: TP is total pressure developed, SP is the static pressure that is the pressure exerted, and VP is the velocity pressure that is the pressure created by the air velocity.

The power required at the rated flow and the pressure at the sea level is expressed as:

$$AHP = \frac{cfm * TP}{6356} \quad (2.27)$$

$$EHP = \frac{cfm * TP}{6356 * FE} \quad (2.28)$$

Or

$$EHP = \frac{cfm * TP * 0,746}{6356 * FE * ME} \quad (2.29)$$

Where: AHP is the power at the rated flow and pressure at sea level, EHP is the electrical power at the selected motor efficiency in KW, PE is the mechanical efficiency of the selected motor per unit in percentage and ME is the motor efficiency of the selected motor per unit in percentage.

#### ➤ Duct

Ductwork is part of the air handling system and includes the supply, return, outside air, relief air and exhaust air duct, explained (Janis & Tao, 2005). The supplied air flow in the duct system is classified as low pressure/velocity, medium pressure/velocity and high pressure/velocity. The low velocity is used when the small air flow and large quantities are required. Low pressure velocities use less power for distribution, reduce frictions and

air noise although it occupies big space. The high velocity enhances the conservation of the space and duct material.

The sheet of galvanized steel, aluminium or stainless steel is widely used for fabricating ducts. Sometimes non-metallic material is used. Ducts are fabricated in shape of rectangular, round, and flat oval. The rectangular shape is the most often used for low velocity armed with insulation material to the interior of the duct this method offers an acoustic absorption as well as thermal insulation. Round or flat oval ducts are used for medium and high velocities duct work. In this case they usually apply external insulation. And a sound absorber may be installed just downstream of the fan. The terminal units are used to throttle the air to a low velocity and attenuate the noise.

#### ➤ Piping system

The HVAC system is based on the conduction of heat by fluid flow. Among these fluids there is air, water, steam, refrigerant and so forth. For that reason piping system is used to transport the fluid from one component to another. The flow of fluid in a piping system depends on factors such as properties relating to the fluidity (viscosity, and specific gravity), phase (liquid, vapor or gas) and physical states (temperature, pressure and velocity) (Janis & Tao, 2005).

To pass up pressure losses produced by friction and harmful noise, the piping system should be large enough. The piping system does not consist of only pipes. Besides pipes, there are others components such as: valves, coupling, air controller, oil controller, oil separator and so on.

#### ❖ Pipe

Pipes are tubular material designed to transport fluid energy from one element to another device. In the HVAC system, pipes are fabricated in different materials such as: galvanized steel, copper, cast iron and so forth. To prevent corrosion, non-metallic materials are used such as: fibre glass, plastic, or the special material (stainless steel and aluminium).

The plastic or fibre glass pipes: Polyvinyl chlorides (PVC), Polybutane (PB), Polypropylene (PP), and Polyethylene (PE) are economical alternative to metal, but they are very fragile and exposed to water hammer.

Soldering, brazing, welding, screwing, solvent-welding and mechanical coupling are different methods used to join pipes. The mechanical coupling presents more

advantages compared to other methods. Mechanical coupling is less expensive, flexible to relieve stresses and thermal expansion.

- ❖ Valve

Valves are devices installed in the piping system, the valve serve to put “on or off” the flow of the fluid manually or automatically. In other words, valves serve to control the flow of the fluid in the hydraulic and pneumatic systems.

Valves are used for multiple functions, they may be used to isolate components and portions of systems, to adjust the flow through the system in proper amount to save load, to modulate the flow of fluid through head transfer devices in response to fluctuating load, to avoid unacceptable light system pressure at light load conditions, to bypass the fluid, to reverse the systems and other applications.

There are several types of valves that are made in various designs and various materials and types of construction. Each has specific working characteristic especially in fluid control systems

- ❖ Fitting and accessories.

To perform the functioning in the piping systems, many fitting and accessories are required such as: piping fitting elbows, tees, flanges, coupling union, strainer, pressure and temperature taps and others.

- Air cleaning systems

The use of air cleaning systems is to clean the air that we breathe. There are two methods used in those systems, the humid system and the dry system. In the humid system, the air is cleaned by passing through a liquid curtain through the spray. In the dry cleaning system, air is cleaned by passing through cleaning devices. The common device widely used to clean air in the dry cleaning method is the air filter. The air filter is based on certain characteristics such as: efficiency, resistance to air flow, duct holding and life cycle cost of the system.

- Air Devices

Air devices are used for supplying air and removing air from space. Air devices such as grilles, registers, and diffusers are among the parts of HVAC systems that are visible to the occupants of the building (Janis & Tao, 2005). Normally grilles and registers are equipped with vanes for directing air flow. They can be fixed in the ceilings, in the walls

or floors as aesthetic or decorative way. The diffusers are often installed in the ceiling fixed with louvers, slots or vanes.

#### 2.4.6 Solar air conditioner

“Air conditioner is one of the consumers of electricity in many parts of the world today” explains (Nathan Rona, 2004:9). It is for that reason; many researches on solar air conditioner are made to overcome the problem. Solar air conditioning system might be a way to reduce the demand for electricity.

The solar air conditioning systems can be divided into two groups of systems: solar autonomous system and solar assisted systems. In a solar autonomous system “all” energy used by the air conditioning system is solar energy. The word all is in between quotation marks because often systems called solar autonomous still use grid-provided electricity to drive fans and pump (Nathan, 2004:97).

Two measures of interested in solar-autonomous systems are  $COP_{sol}$  and  $SPL_{sol}$ .  $COP_{sol}$  gives the momentary performance of the entire system and is defined as:

$$COP_{sol} = \frac{Q_{o,sol} 10^3}{I_{ca}} \quad (2.30)$$

Where:  $Q_{o,sol}$  is heat removed (by using of solar energy) from conditioned space,  $I_{ca}$  is solar radiation, and A is solar collector area.

$$.SPF = \int \frac{Q_{o,sol} 10^3}{I_{ca}} dt = \int COP dt \quad (2.31)$$

Where:  $\eta_c$  is solar collector efficiency, and PE is a primary energy

##### 2.4.6.1 Solar energy

The sun is the main source of all energies, including solar energy. Regarding our system, the solar energy will be collected to supply the system, (Krauter, 2006). Solar energy collection, as the name suggest is to collect energy provided from the sun to transform this energy into something useable, electricity, heat or both, (Nathan, 2004).

The efficiency of a solar collector is defined as:

$$\eta_c = \frac{E}{I_c A_c} \quad \text{or} \quad \eta_c = \frac{\int E_c dt}{I_c A_c ds} \quad (2.32)$$

Where  $E$  is a collected energy measured ( $W$ ),  $I_c$  is a solar radiation ( $W/m^2$ ) and  $A_c$  is a solar collector aperture area measured in ( $m^2$ ).

There are three groups of solar air conditioning systems according to power supply to the system, among them there are:

Photovoltaic cells or a solar cell air conditioning which the solar radiation is transformed directly into electricity to supply the air conditioning system, The solar thermal collector air conditioning system that converts the sun's radiant energy into heat energy, and the system using both. The solar air conditioning is also divided in two types of systems: solar autonomous system and solar assisted. According to the power supply to the system, the photovoltaic cell air conditioning has more advantage compare with others, but the biggest inconvenience is, the system costs much more than others and requires others devices such as convector, accumulator and so on. Regarding the choice we suggest to choose the solar collector air conditioning.

#### **2.4.6.2 Solar collector air conditioning components**

Comparing the solar collector air conditioning system to electrical air conditioning system, there is a similarity in terms of some based elements composed modelled above such as condenser, evaporator, and expansion device. The solar collector air conditioning system is using vapour absorption refrigeration systems, the compression is replaced by the generator, and this one completes others components such as: solar thermal collector, thermal pump, rectifier, absorber, regenerator and other components.

The solar thermal collector converts the sun's radiant energy into heat energy. The basic principle solar thermal collector is that, when solar radiant strikes a surface, part of it is absorbed, thereby increasing the temperature of the surface, explains (Nathan Rona 2004:66). There are various types of solar thermal collectors such as: flat plat thermal collector, Evacuated Tube Collector (ETC), parabolic dish collector and central receiver's collector. In the thermal heat pump air conditioning system, heat from the solar collector is used directly to remove heat from the conditioned space.

The generator is like a heat exchanger, it produce refrigerant vapour by heating refrigerant-rich solution with a heating medium. The generator is a shell and tube, type heat exchanger where the heating medium flows through the shell side in an upward cross flow configuration and refrigerant vapour is generated from the solution that flows downward inside the vertical tubes.



We gave you a general idea of HVAC system and the overview of solar air conditioning system that today attracts more attention to researchers. In the following point we explain the automation system on the building.

## **2.5 Building automation system**

### **2.5.1 Introduction**

“We need controls and control systems because in our modern age of technology, they make our lives more convenient, comfortable, efficient, and effective“(Montgomery & Dowell, 2009). (Merz et al., 2009), building automation and control system allow pursuit of energy management: they provide complex and integrated energy saving function based on the actual use of a building.

### **2.5.2 Definition of building Automation**

(Merz, et al., 2009)“ Building automation is the computerized measurement, control and management of building services”. The HVAC equipment, lighting system, and so on are controlled and computerized, that means an automation system in a residential building; building devices are controlled, such as the use of control function in heating system, automatic light control. Building control is a specific subdivision of building automation that focuses mainly on electrical installations. The building control refers to the use of an installation bus to connect system components and devices to a system designed for specific electrical installations that control and connect all the functions and processes in a building. Each component has got its own intelligence and swap information with each other.

### **2.5.3 Utilities**

“We need controls and control systems because in our modern age of technology, they make our lives comfortable. “The control system is best for energy management “according to (Montgomery & Dowell, 2009), it means that the control system is providing the essential appliance function and it should do so in the most energy efficient manner possible.

According (Honeywell, 1997) “A control designed HVAC system can provide a comfortable environment for occupants, optimize energy cost and consumption. Automatic controls can optimize HVAC system operation. They can adjust temperatures and pressures automatically to reduce demand when space are unoccupied and regulate heating and cooling to provide comfort while limiting energy usage.”

(Simpson, 2003) Stated that “lighting control can make a big contribution to energy saving”. It should be possible to program its operations so that it uses energy in the most efficient manner. Briefly the automation system will mitigate the energy consumption in the building.

Normally in the residential building, automation system presents many utilities such as: the use of control functions in heating systems for optimal regulation of consumption, fire and combustion controller, room temperature regulators (thermostats), automatic lighting, cost effectiveness/ saving energy, comfort and convenience, and security.

#### 2.5.4 Structure of building automation and control network

Generally the hierarchical structure of building automation is structured with 5 levels such as the management level that is the top of the structure, following respectively by primary control functions, control and regulation, operational system interface and closing up with assemblies forming the base of the structure(Figure 2.9)

(Merz, et al., 2009), the management level consists of control computer that runs all the necessary building management programs including logging all events, archiving all measured readings, and graphically displaying the status of the operational system.

The primary control function and control and regulation level are composed of Direct Digital Controller (DDC), that is connected to sensors and actuators via wires (twisted pair). One wire serves to send messages and the other one serves to transmit sensors signals. The DDC control and regulate the systems.

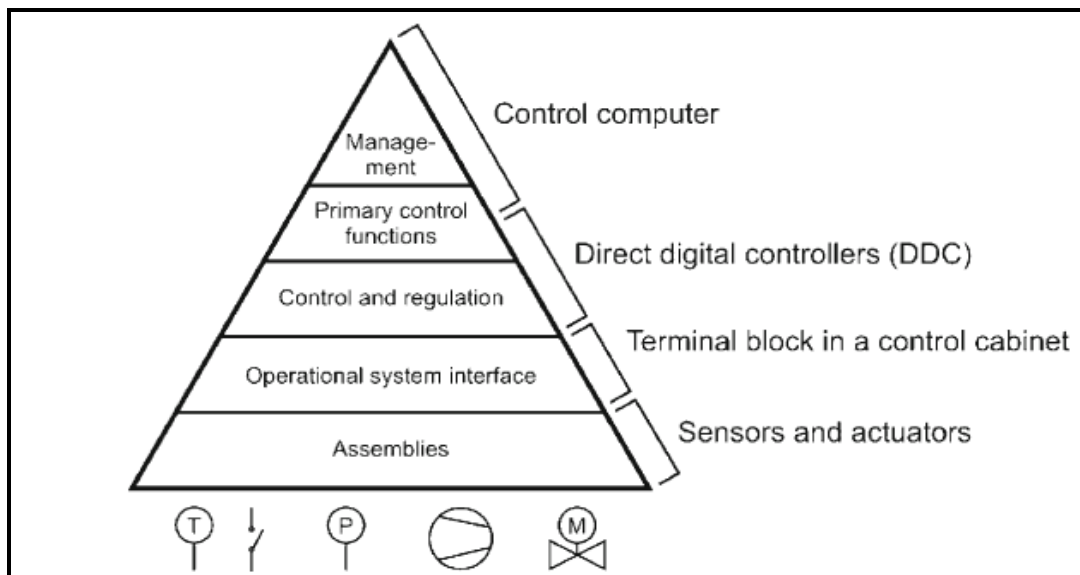


Figure 2.19The hierarchy structure in the building automations

Operational system interface is incorporated in the microcontroller. This device is used for HVAC control, to regulate the controlled zone temperature by comparing the set temperature with the controlled zone temperature reading, and then transfers the output signal via bus to the heater's in-built electrical actuator.

The assemblies' level regroups sensors and actuators, valves and other devices.

### 2.5.5 Energy management functions

Energy management is one of the main objectives of building automation that leads the systems in building to operate efficiently. The energy management is the operation that control and manage carefully the use of energy in the building to avoid overconsumption and misuse of energy in the building.

, energy management most commonly used in Building Automation are:

- Payback period

The role of this function is to calculate the reduced building's operating cost by the automation system and to predict to period that the investment cost will be covered with the energy saved by the automation system.

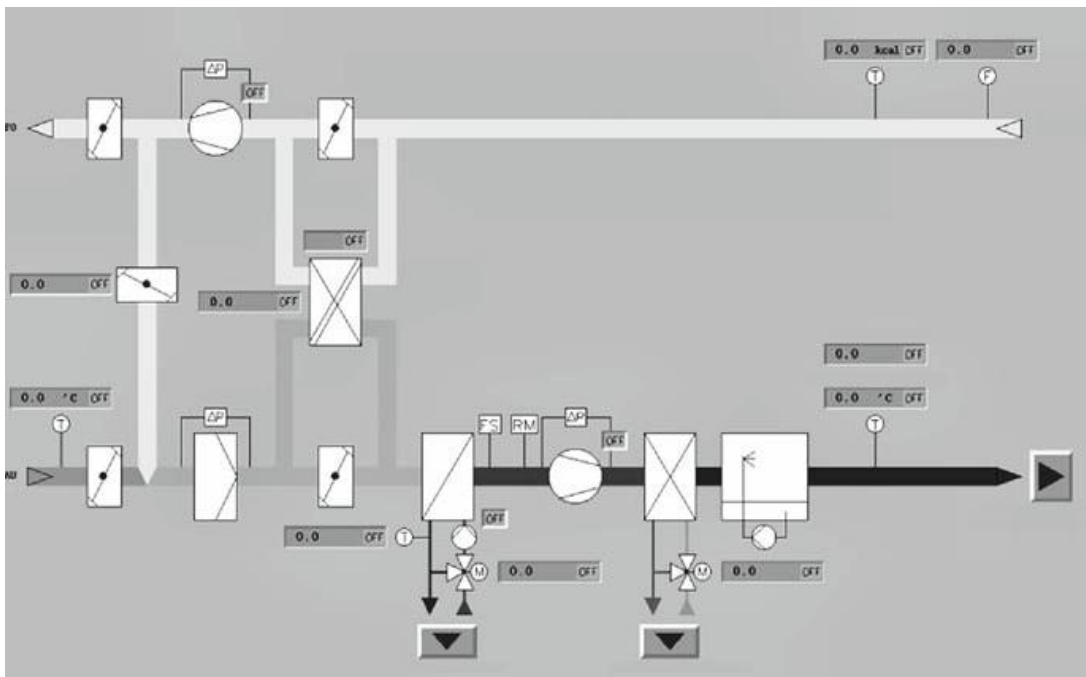


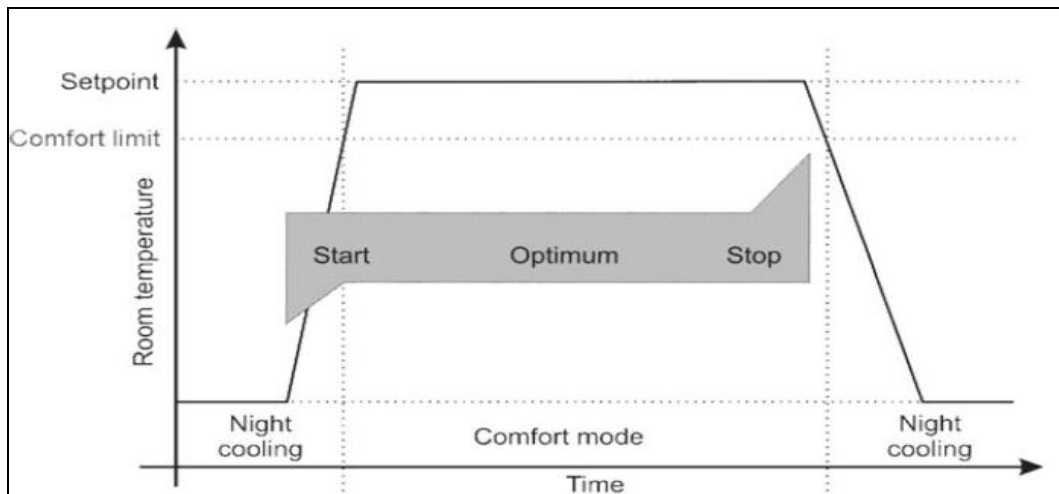
Figure 2.10: A ventilation system displayed on a control computer (Guptan, 2003)

- Optimum start/stop

Optimum start/stop is an advanced function used at the management level. Optimum start/stop switches the system on and off according to the users schedules (Montgomery & Dowell, 2009). Optimum start/stop program on the other hand is self-regulating and uses outside/inside temperatures and uses the thermal characteristics of the building to calculate the optimum times to start and to stop the system(Figure 2.19)

➤ Duty cycling

Duty cycling is a function normally relevant to oversized installations. Duty cycling runs large loads intermittently. In other words, duty cycling shuts down large loads for laps of time, to avoid the overconsumption.



**Figure 2.11: Optimum start/stop (Merz, Hansemann, & Hubner, 2009)**

➤ Limiting peak demand

Limiting peak demand program records the amount of electricity consumed over 15 minute periods, then calculate the energy demand for this period (Merz et al, 2009). If the demand is running faster than the set value of time, the program will switch off selected large loads for a laps of time till the demand will be running to the conformed set time. In other words, the load must run up in the same phase with the agreed value of time. If the demand exceeds the agreed value of time, the program will shut off selected large loads (Figure 2.12)

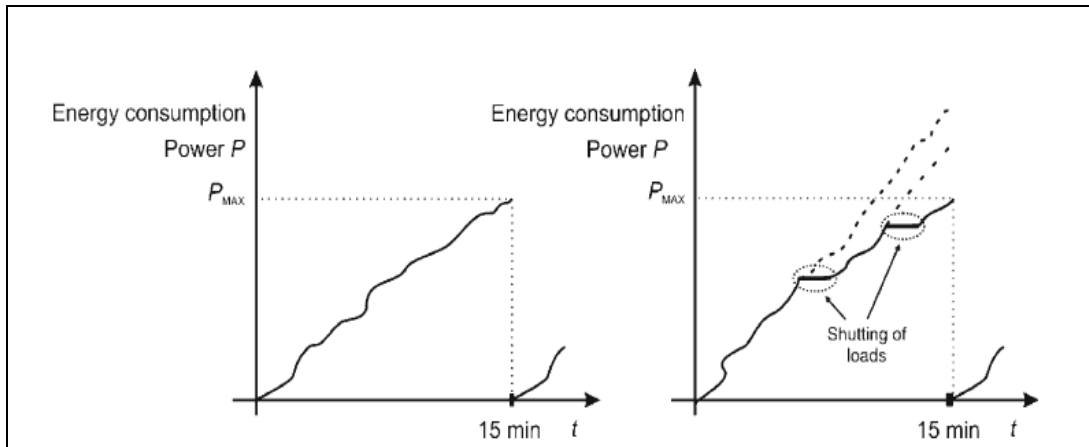


Figure 2.12: Limit peak load (Merz, Hansemann, & Hubner, 2009).

## 2.5.6 Main components and devices of building automation system

A control system consists of three basic elements such as a sensor, a controller and a controlled device. The sensor samples some variable values and send the information of these values to the controller. The controller compares these values to the set point value. If the sampled value and the set point are not identical, the controller will act on the controlled device to adjust these two values.

### 2.5.6.1 Sensors

The sensors are the hinge device for control system that measure the controlled variable and send the information to the controller. Without sensor there is no control system. Sensors are also used for monitoring purposes to keep the operator informed about elements in the system that indicate proper or improper information ( (CIBSE, 2000).Sensors are categorized in several functions such as sensing element, transducer, transmitter, active device, passive device and so on.

In the Building automation system, the most commonly used sensors for lighting, HVAC systems and security applications are: temperature sensors, humidity sensors, pressure sensors, velocity/flow sensors, airs quality sensors, presence detector, day lighting detectors, and fire and combustion detectors and forth.

### 2.5.6.2 Actuators

An actuator is an execution device that acts on output system to stabilize the system by providing adequate output. (CIBSE, 2000), An actuator responds to the output signal from a controller and provides the mechanical action to operate the final device, which is typically a valve or damper in HVAC systems.

### **2.5.6.3 Controller**

The Controller serves to get information from the sensor and compare that information with the set point values. If these two values are not identical that means there are some disturbances in the system, and the controller will command the actuators to regulate the system.

### **2.5.6.4 Direct device controller (DDC)**

A DDC is a control operated digital microprocessor. (Montgomery & Dowell, 2009), in a DDC system, all the inputs and outputs remain: however, they are not processed in the controllers, but all logic control is carried out in the computer, based on instructions called the “logic control”. In DDC, all control functions and logic are executed in software.

## **2.5.7 Standardized bus systems and Networks in building automation systems**

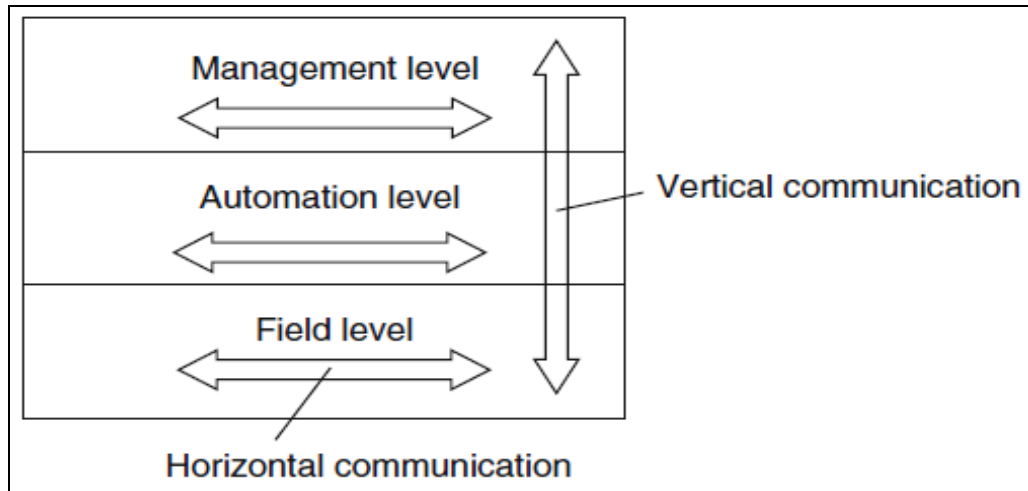
In the building automation systems, devices communicate with each other. In the other words, devices from the same level (Horizontal) transfer information with each other, and devices from different levels (Vertical) transfer information with each other that allows performing the automated functions at various levels (Figure 2.13). Sometimes interference problems occur in the communication system between devices, due to the transmission of many messages at the same time. In the medium sized administrative building alone, more than a thousand messages are transferred between the automation stations of various systems and control computer.

To overcome these problems, the bus system has been established as efficient and economical solutions. (Merz et al 2009), Recent years, the demand of building automation system has been increased considerably. That is why several bus systems from different manufacturers have been injected on the market.

The bus system from different manufacturers on the market came up against the big problem that is the lack of interoperability. The only way out was that one of the manufacturers would have to reveal its protocols to others called “open protocol”. Due to the increasingly complex nature of these systems, the demand for European open protocol bus systems has risen grammatically (Merz, Hansemann, & Hubner, 2009).

Amongst these many bus systems and networks on the market, only some of them have been standardized by European Standardization and they are denoted by the letter ENV, and EN symbolizes European Standard and ISO/IEC. The bus system and networks

widely used in the building automation system are: LON technology, KONNEX, BAT/bus, and EHS bus system. So far BAC net is the only protocol used for data communication at the management level (Merz et al, 2009).



**Figure 2.13: horizontal and vertical communications in building automation model (Merz et al 2009)**

### 2.5.7.1 Standard bus system

There is several standardized bus systems used in building automation control communication system. In this work we will focus on some of them such as: KONNEX (KNX), LON and BACnet).

#### ➤ KONNEX (KNX)

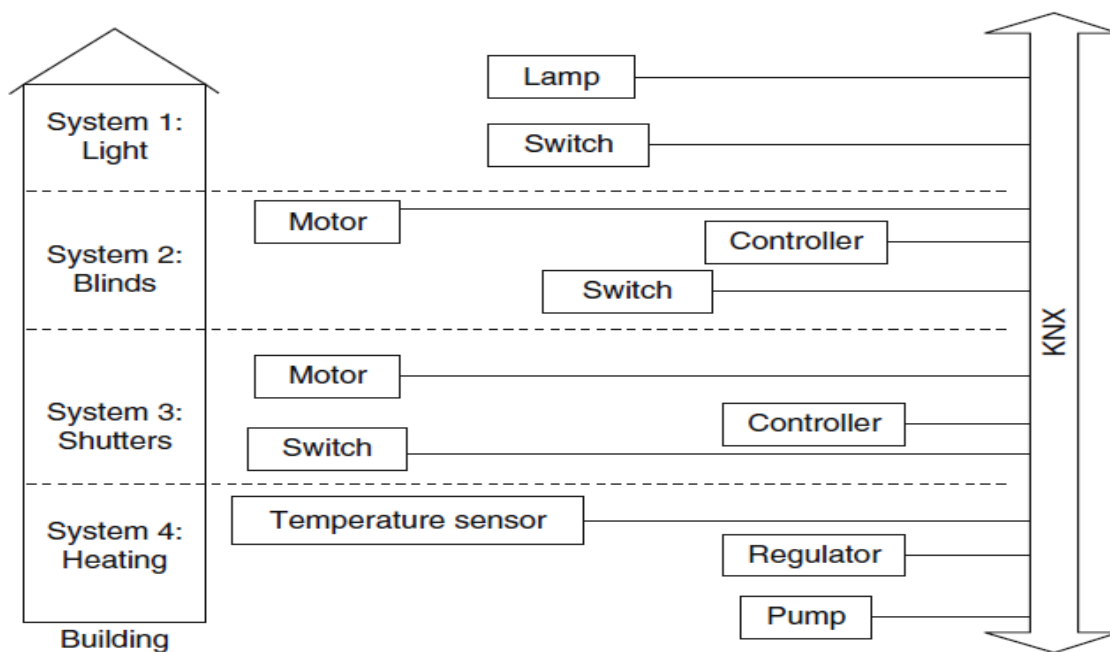
The conventional building installation technology came up against serious predicaments such as complexity, huge effort and cost of planning, requiring a vast amount of wiring that lead to fire risk, tough maintenance and so forth. KNX provides the way out from these predicaments although it requires high investment cost.

(Merz, Hansemann, & Hubner, 2009), KNX is an industrial bus system used in building control system that enables exchange of message between control devices and connect devices such as sensors, actuators, controllers, operating thermals and monitors at lower cabling cost by simplifying the system (Figure 2.14).

KNX is from the European Installation Bus (EIB) that uses diversity of transmission media such as twisted pair cable (KNX.TB), Power live (KNX.PL) and Radio Frequency (KNX.RF).

In December 2003, KNX has been modified to the perfection by CENELEC as the European Standard EN50090. And in 2006 a large section of the EN 50090 was approved for inclusion in the ISO/IEC 14543 (Merz, Hansemann, & Hubner, 2009).

KNX installation requires various kinds of bus devices (Merz, Hansemann, & Hubner, 2009). KNX specialist manufacturers provide lists of products referred in the KNX catalogue or KNX website. These products are classified in four main groups such as: system components (power supply units, accumulator, lines couplers, backbone couplers and so on), sensors, actuators and other devices such as logical component and control panel.



**Figure 2.14: Building control with KNX integrated system, lower cabling cost (CIBSE, 2000)**

➤ LONWORK (LON)

LONWORK is an open networking solution for building automation and networks that was developed by the American Company Echelon. Normally LONWORK is a bus system standardized by ANSI/CEA-709.1-B and ISO/IEC DIS 14908 that allows the communication between intelligent devices (Simpson, 2003).

LON can be used in both system such as centralized building automation and decentralized building control component. In the centralized system, all sensors and



actuators are directly connected to a central control system whereas decentralized building automation system, the control functions are in the system. Decentralized building control is more developed compared to centralized building automation.

LONWORK comprises three groups of components such as: hardware component, software applications and organizational structures. The basic LON components are: Neuron chip that is the brain of LONWORK system, LON TALK Protocol that defines how Neuron chips are programmed for different applications and how they communicate with each other as nodes in the network, Transceivers is one of the main elements of each network device, LON WORK Tools.

➤ BACnet

BACnet (building Automation and Control Network) was developed by the ASHREA to provide communication between devices and system in the building automation. BACnet improves the interoperability between various automations and components from different manufacturers in the building automation.

In BACnet, messages are transmitted in various ways such as local area network (LAN) that is particularly the best way for transporting message, MS/TP that is very simple with the lower cost however the transfer rate of message is very slow, LONTALK, Ethernet the more expensive that has been introduced CIRCA 1970 and standardized as IEEE 8023 with the fastest data transfer compared to other protocols, ARCNET and so on.

### **2.5.7.2 Bus network Topology**

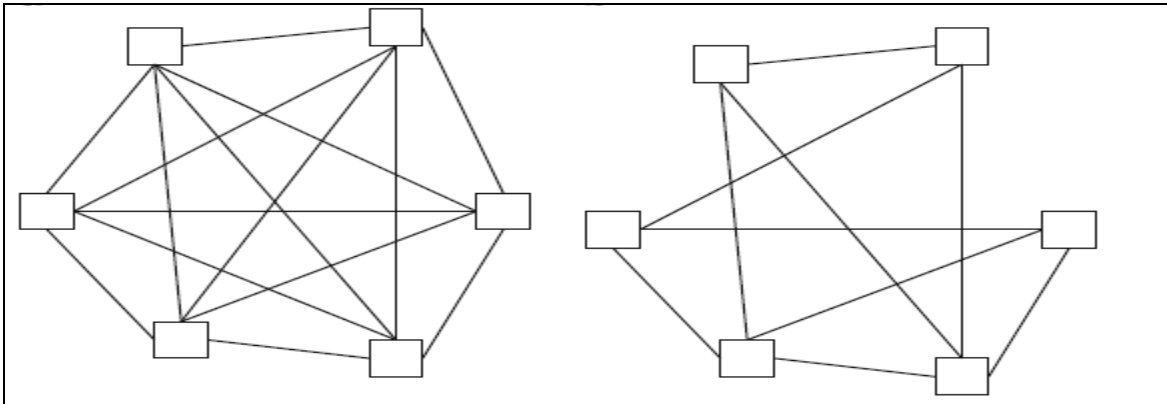
The network topology is called media access control protocols and prevents the transmitted signal from being disrupted if more than one device transmits data at the same time over a field bus or network (CIBSE, 2000).

In Building automation control, there are some topology the most widely used such as:

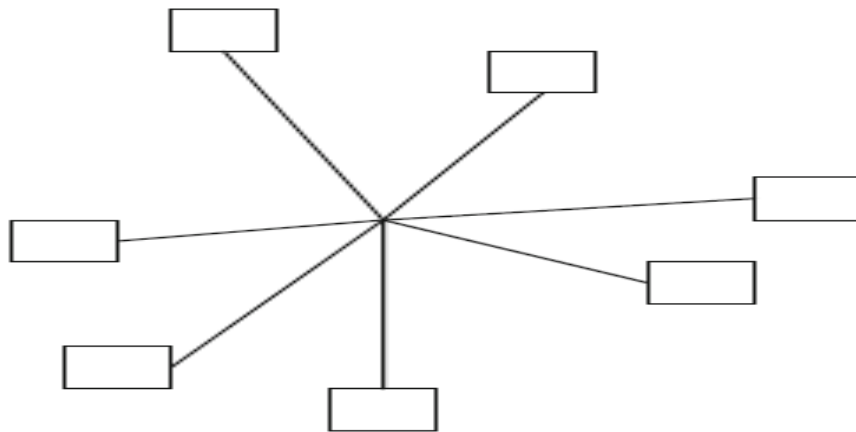
- Full mesh topology: all devices are connected with each other devices(Figure 2.15a)
- Partial topology : only main devices are connected with each other (Figure 2.15b)
- Three topology: that consists of many branches connected to the main line called “backbone line”(Figure 2.17)
- Star topology: in the star topology all devices are connected to one node called “Hub” (Figure2.16)

To wrap up with this point, three topologies have been taken as a structure of conventional building installation. According (Merz, Hansemann, & Hubner, 2009), three topology has

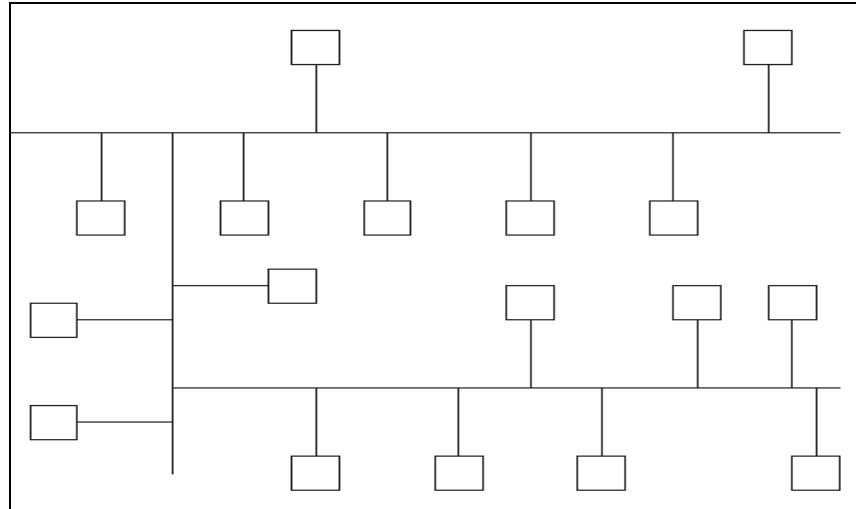
- Nodes (N) that are assigned to a line( L)
- Several lines are connected with each other via the main line (ML) and form an area( A)
- Several areas are connected with each other via the back line( BL)



**Figure 2.15: Full mesh topology on left side (a) and partial mesh topology on right side (b) (Merz et al 2009)**



**Figure 2.16: Star topology (Merz et al 2009)**



**Figure 2.17 tree topology (Merz et al 2009)**

With the new technology, full mesh topology is the most widely used in building automation system because it allows all devices of the system to communicate with each other.

As a conclusion for building automation system, we notice that building automation system is the best way for energy management and efficiency, and provides comfort and convenient indoor atmosphere.

In the second chapter, we did explain on the second category end use of electrical energy, the following chapter we explained about building energy modeling and the new modeling language (system modeling language) that we have to use for our model.

## **CHAPTER THREE**

### **BUILDING ENERGY MODELING AND SYSTEM MODELING LANGUAGE**

#### **3.1 Models and simulations**

A model is a representation of our ideas on paper that helps us to understand and to improve the concept, for this reason a model is used as backup for the conception. In system engineering, a model is a crucial tool, a hinge for designing process and a guideline to setup a system design. In other words, a model is a kind of language that allows the designer to express his design to others. (Holt & Perry, 2008), defines a model as a simplification of reality. In other words, a model is a simplified representation of the system, in order to understand the system. A model can be represented in different ways such as a mathematical model, textual models, physical/practical model, and visual model.

Moreover, a simulation predicts the behaviour of the system. Model and simulation are commonly used in all stages of the design process. This is particularly vital to the success of the systems engineering project where the system under consideration is complex and involves interactions between many interdisciplinary subsystems. Models and simulations can be used to refine and optimize a system with respect to the decision maker's objectives (Moore & Paredis, 2009). According to (Holt & Perry, 2008), the complexity of the system, misunderstanding and lack of communication issues are three evils of engineering systems. In other words these three elements are the main causes of project failure. So the model and simulation are the best way to eliminate these three evils.

For the next point we are going to break down system modeling language and giving all diagrams of system modeling language.

#### **3.2 System Modelling Language (SysML)**

##### **3.2.1 Definition of system modeling language**

SysML is a general purpose graphical modeling language for specifying, analysing, designing, and verifying complex systems including hardware, software, personal information and facilities (Holt & Perry, 2008). SysML is a visual modeling language that provides semantics and notations. SysML is based on Unified Modeling Language (UML). In other word SysML is the extension of UML.

A short description: UML is a general-purpose graphical modeling language aimed at software engines which appeared in 1997 that is originally from the initiative between

OMG and INCOSE (OMG, 2003). UML is the strongest and the most used modeling language in the past in System engineering compared to others modeling languages. UML was used very successfully for system engineering activities in many application domains for many years (Holt & Perry, 2008). UML is used to specify visual, modify and to build necessary support for reliable development of object oriented software. With UML modeling tools, it is possible to run automatically code.

UML consists of 13 types of diagrams that are divided in two groups such as behavioural and structural. The structural diagram regroups six diagrams such as class diagram, package diagram, composite structure diagram, object diagram, component diagram and deployment diagram. The behavioural regroups seven diagrams such as state machine diagram, activities diagram, use case diagram, timing diagram and interaction diagram.

To perform weaknesses of UML, several numbers of industries such as BAE, OOSE, Motorola, Boeing, IBM, universities and INCOSE have been working up to give a reliable shape to SysML. Now SysML can be used in any field of engineering system.

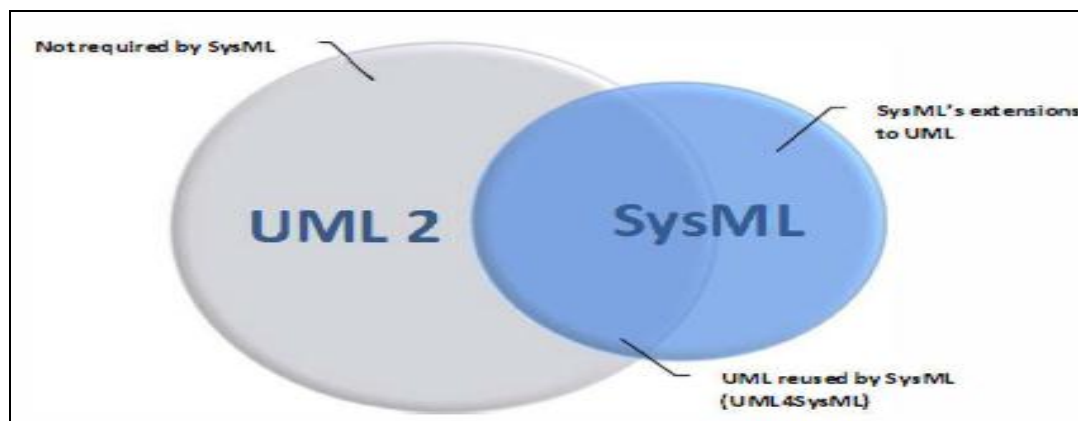


Figure 3.1 SysML and UML relationship

### 3.2.2 System Modeling Language diagrams

As we said above, SysML is an extension of UML. That is to say SysML uses most of UML diagrams (figure 3.1). In fact SysML is not a new modeling language because most of SysML diagrams are from UML. And we can say SysML is an innovation of UML, in other words SysML improves some weaknesses of UML. (Holt & Perry, 2008) SysML adds some new diagrams and constructs not found in UML: the parametric diagram, the requirement diagram and flow specifications and item flows. SysML defines also new types of associations (link of dependency stereotypes) such as derive, satisfy, verify and refine.

SysML is constituted of nine types of diagrams, such as: structural diagrams, behavioural diagrams, and requirement diagram (Figure 3.2). Whereas a structural diagram regroups: Block Definition Diagram, Internal Block Definition, Package Diagram and Parametric Diagram. Behavioural diagram regroups: Activity Diagram, Sequence Diagram, State Machine Diagram and Use Case Diagram.

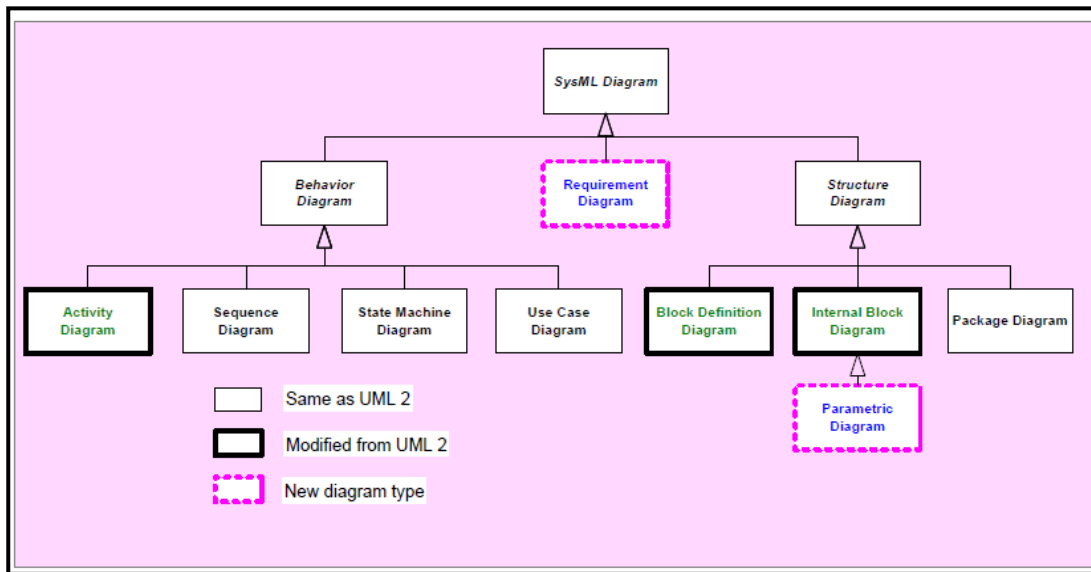


Figure 3.2: SysML diagrams

### 3.2.2.1 Bloc Definition diagram (BDD)

The BDD serves to show and to present all components of the system and their relations. BDD is a kind of system's black box that enumerates each elements of the system through blocks. Blocks describe types of things that exist in the system and the relationship brings to light the links that exist between blocks.

(Holt & Perry, 2008) BDD is made up of one or more "blocks", zero or more "relationships", zero or more "interfaces", zero or more port and zero or more Items flow.

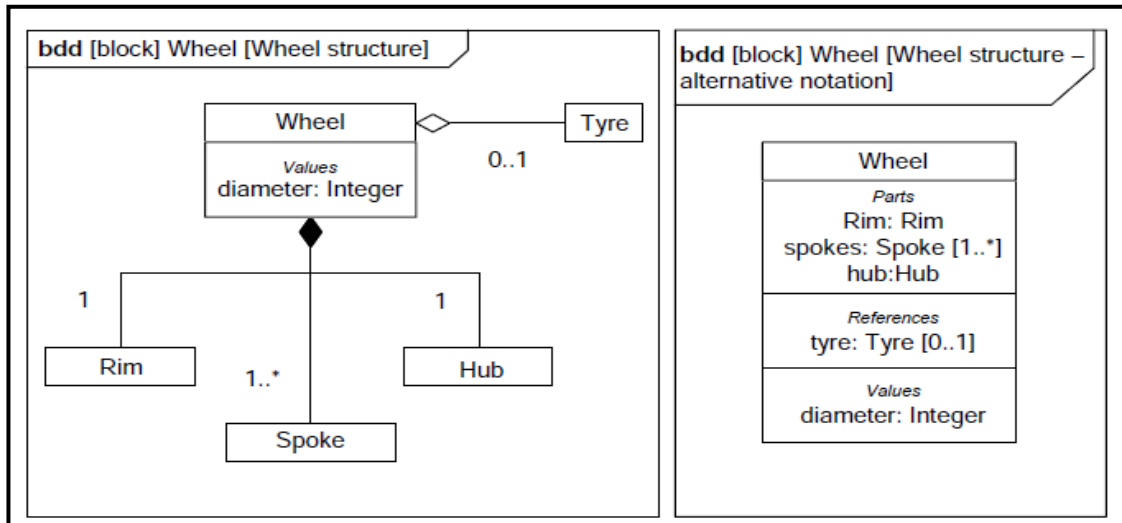


Figure 3.3: Types of property- alternative representations

### 3.2.2.2 Internal Block Diagram (IBD)

The IBD is called the “white box” because this one describes and digs out the internal structure of the system. IBD reveals the structure of the system’s heart and describes how blocks are connected with each other. Normally IBD are used to model the internal structure of blocks (hence the name) and can also be used to show how the system elements are deployed (Holt & Perry, 2008).

IBD is composed with one or more “Part”, zero or more “Ports” (Standard port and Flow port), zero or more connectors. A port enables to define an interaction point for a “Part”. (Holt & Perry, 2008), a Part can be directly connected to zero or more Ports via building connectors (Figure 3.4)

### 3.2.2.3 Package diagram

Package diagram allows structuring the model in everything. Package diagram identifies diagrams and establishes links between packages. Other diagrams use packages as well as package diagram.

Package diagram is made up with packages. And each package shows a collection of diagram elements and implies some sort of ownership (Internet). Figure 3.5 shows a meta-model of Package Diagram.

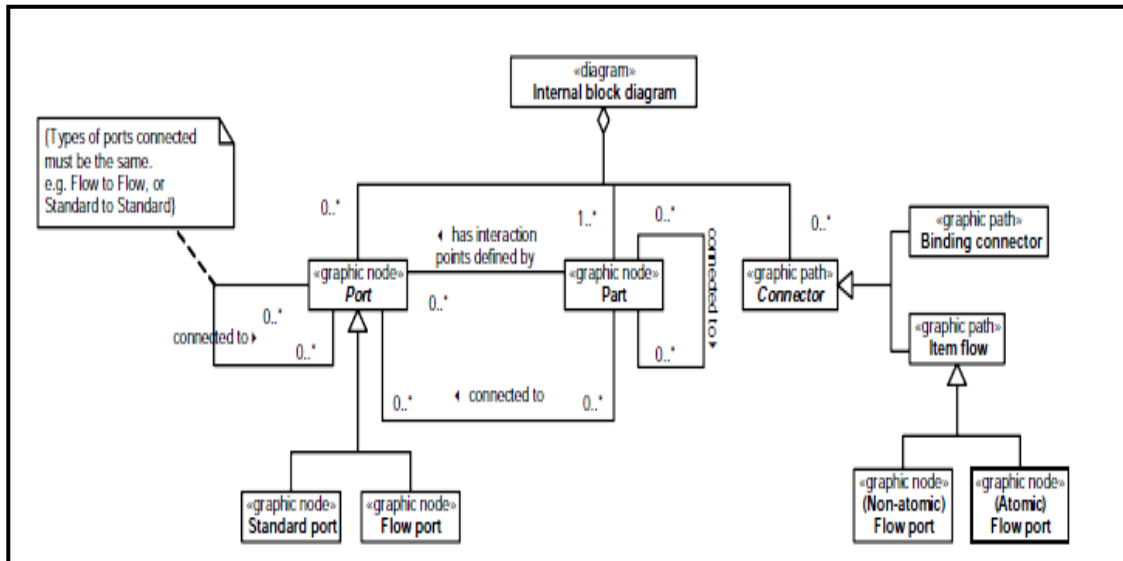


Figure 3.4: Partial meta-model of the Internal Block Diagram (Holt & Perry, 2008)

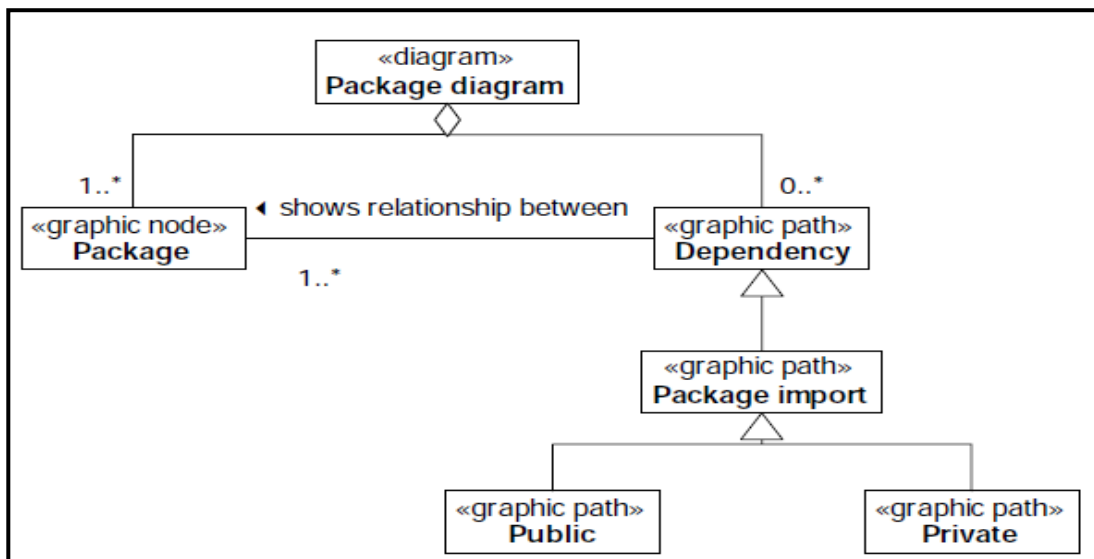


Figure 3.5: Partial meta-model for Package Diagram (Holt & Perry, 2008)

### 3.2.2.4 Parametric Diagram

Parametric diagram refines IBD and enabling to relate the reliability and effectiveness of the system with constraint blocks. Constraints blocks are mathematical expression to which the parameters are referred to system's elements. According to (INCOSE, 2006), constraints blocks allow for definition and use of networks of constraints that represent rules that constrain the properties of a system or that define rules that the system must conform to.



Package Diagrams are composed of one or more constraints blocks, zero or more “Parts” and one or more connectors. The constraint blocks serve to identify the constraints that have being used for modeling. Figure 3.6 shows a partial meta-model of parametric diagram.

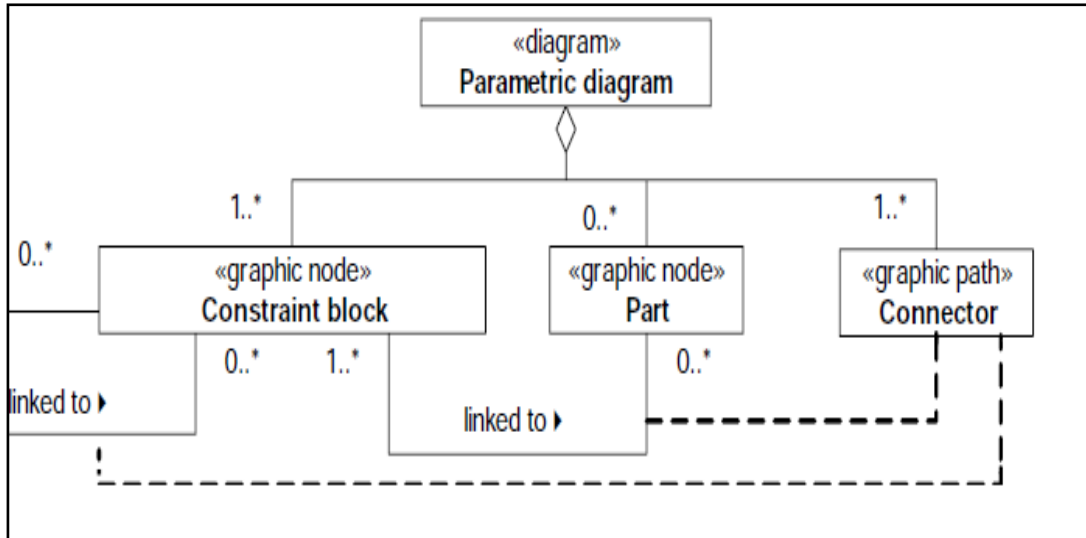


Figure 3.6 Partial meta-model of parametric diagram (Holt & Perry, 2008)

### 3.2.2.5 State Machine Diagram

State Machine Diagrams realize a behavioural aspect of the model and are sometimes referred to as timing models, which may, depending on your background, be a misnomer (Holt & Perry, 2008). The behaviour of the system is modelled by the State Machine Diagram during lifetime of the block.

State Machine Diagrams is composed with two basic elements, such as State and Transition. And these basic elements of state machines describe the behaviour of the blocks according to logical times. State show what is happening at any particular point in logic time. In other words, states show the beginning, the evolution and the end of activities and a Transition show how to change between one or two states.

There are four types of states such as “Simple state”, “Initial State”, “Final state” and “Composite state”. Each state is composed with zero or more “Activity” and activity describes an ongoing, non-atomic unit of the behaviour and is directly related to the operations on blocks. Figure 3.7 depict Partial meta- model of the State Machine Diagram.

### 3.2.2.6 Sequence diagram

Sequence diagrams serve to describe the ensembles of the scenarios identified (nominal, alternative and errors) and the interactions between actors and the system. In other words Sequence Diagram allows one to describe textually the interaction between actors and system that are represented in Use case Diagram. (Holt & Perry, 2008), the main aim of the sequence diagram is to show a particular example of operation of a system, in the same way as moviemakers may draw up a storyboard.

### 3.2.2.7 Activity Diagrams

The Activity Diagram allows representing the steps or the stages of operations. In other words, Activity diagram allow one to model the processes of the system. In The Activity Diagram, “inputs and outputs pin’ are used to represent the output, input and flow of activities or action in the system. Activity Diagrams are considered as a special type of a state machine diagram.

Activity Diagrams are made up with three basic elements such as, one or more “Activity node”, one or more “Activity edge”, and one or more “Region”. According to (Holt & Perry, 2008), there are three main types of “Activity node”: Activity invocation, the Object and the Central node.

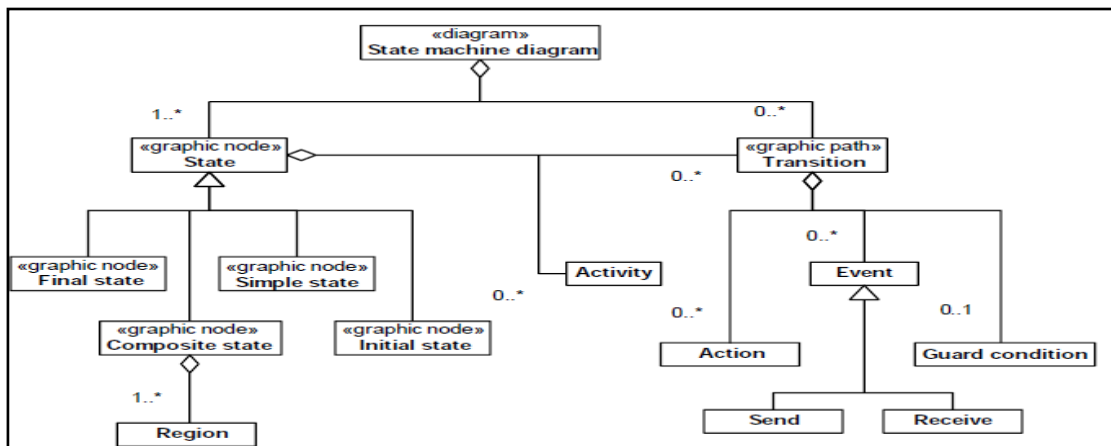


Figure 3.7: Partial meta- model of the State Machine Diagram (Holt & Perry, 2008)

### 3.2.2.8 Use Case Diagram

The Use Case Diagram represents the highest level of abstraction of a view that is available in SysML and it is used, primarily to model the requirements and contexts of the system (Holt & Perry, 2008). Use Case Diagrams are very similar to data-flow diagrams.

Use case (in use case diagram) and processes (in data flow diagram), both their symbols look the same and are represented by ellipses.

Use Case Diagrams are made up with four basic elements such as: use case, actors, associations and a system boundary. Where each use case denotes requirements of the system, an association expresses a very high-level of relationships between two diagram elements. Figure 3.8 depicts the partial meta-model of Use Case Diagrams on the left side and graphical representation of elements of Use Case Diagram on right side.

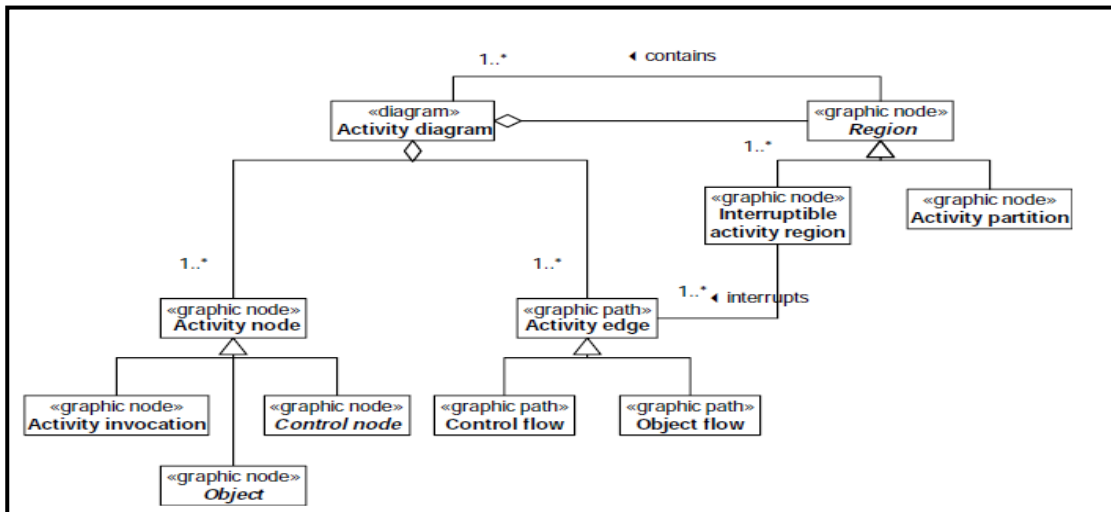


Figure 3.8: Partial meta-model of the Activity diagrams

### 3.2.2.9 Requirement Diagrams

SysML may be used in any field of System engineering. The Requirement Diagrams is composed with three basic elements: requirements, relationships, and text cases. The Requirements Diagrams are one of the most important Diagrams in SysML. Requirement Diagrams are the unavoidable diagrams during the model process in SysML. Requirements diagram are amongst the innovations of SysML.

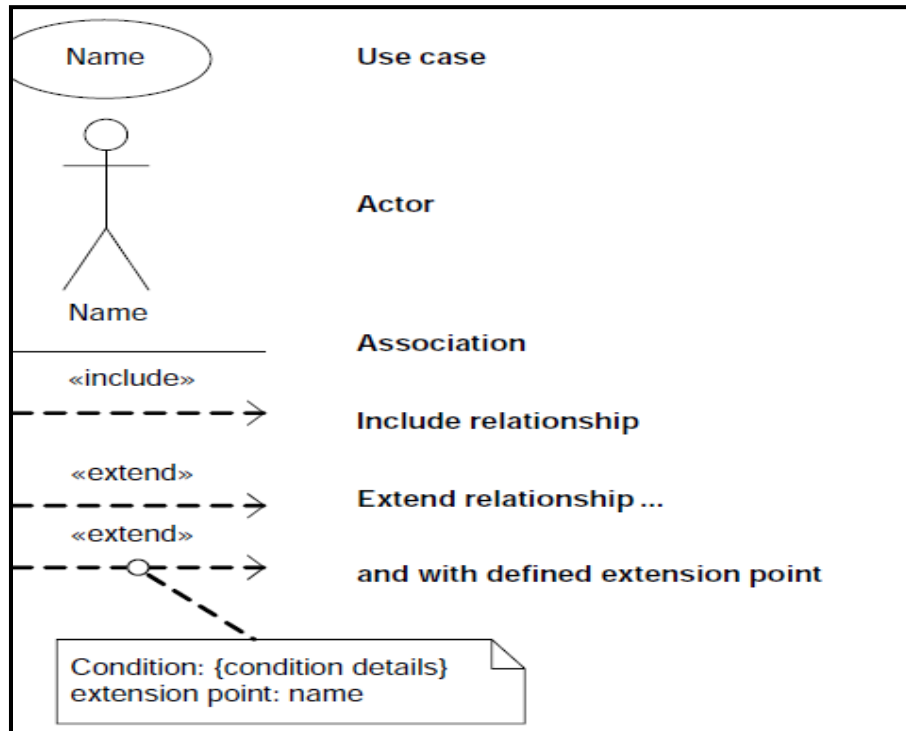
Requirement Diagrams are used to describe the requirements of the system. Requirement Diagrams are used, unsurprisingly to represent the system requirement that can be related to each other and to the system elements via relationships.

### 3.2.3 Advantages of system modeling language

SysML presents more advantages compared to other modeling languages such as:

- SysML is less complex than other modeling languages.

- SysML is more flexible and reliable compared to other modeling languages.
- SysML demystifies the complexity of the system.



**Figure 3.9: Partial meta-model and Graphical representation of elements of Use Case Diagram (Holt & Perry, 2008)**

So far, SysML is the best modeling language and may be applied in any field of engineering system. The following point, we are going to point out some software tools of building energy modeling

### 3.3 Building Energy modelling software

An easy way to solve the energy equations related to a given building environment is to use a building energy simulation tools. There are computer programs that can simulate a building and its HVAC systems. The simulations will help us to calculate with accuracy such as the heating and the cooling loads of the building, as well as the indoor (Preez & Vameulen, 2011).

For the building energy performance simulation, several programs have been developed. These energy simulations software tools run series of inputs to calculate heating and cooling loads, the annual energy consumption and the energy cost for the year. The

building energy model forecasts the building energy efficient, and helps to have the anticipated information that will enable to enhance the building energy efficiency.

For building energy software tools, directory currently list more than four hundred software tools for evaluating energy efficiency, renewable energy, and sustainability in the buildings with approximately one hundred and twenty tools just for whole building energy simulation (Bhandari, 2012).

Amongst the building energy software tools, some have been developed and widely used for building energy modeling such as: HAP, TRACE, DOE2, TRNSYS, SUNREL, HOT 2000, energy plus, Blast, and so forth. These software tools were chosen as the common instruments in the building modeling industry. These programs use different ways to calculate yearly energy consumption, energy cost.

According to (NREL, 2012), there are four generic types of energy simulation software tools: screening tools, Architectural Design Tools, Load Calculation and HVAC sizing tools, and Economic Assessments tools.

- Screening tools:

Screening Tools are designed to evaluate project viability during the earliest stages of programming and often includes some economic analysis capability. They also tend to be correlation, rather full hourly simulation.

- Architectural Design Tools

The architectural design tools are intended to evaluate the relative importance of design decisions such as building orientation, glazing, and day lighting.

- Economic Assessment Tools

Economic Assessment Tools provides comprehensive economic analyses proposed the building capital investment. The building life cycle cost and pay-back period are obtained from the economic assessment tools.

- Engineering Design Tools/ load Calculation and HVAC sizing

Engineering Design Tools/ load Calculation and HVAC sizing are designed primarily to calculate the load, to size and to help to select the equipment such as boiler, furnace, and chiller.

### **3.3.1 Department Of Energy 2 (DOE2)**

(OROSA & Oliviera, 2011), DOE 2 is an advanced engineering software that was funded primarily by the USA DOE to provide a free energy modeling software program. DOE2 was developed by James J Hirsch and associate Lawrence Berkeley National Laboratory ( LBNL).

Many users' interfaces have been created for use with the DOE2 engine, including EQuest. DOE has been extensively validated by comparison with actual measurement and calculation, so in consequence, DOE 2 is highly recommended by ASHRAE as a complete energy tools simulation.

With DOE2, the HVAC system must be selected from a handful of traditional system.

Building Loads analysis and System Thermodynamics (BLAST) provides a simulation of energy consumption, system performance and cost. Blast also computes hourly heating and cooling loads. Data of building skin may be put from library.

The main advantage of this tool is that it does not consider humidity transfer through the building skin and the light expertise level is required.

### **3.3.2 The transient systems simulation (TRNSYS)**

The transient systems simulation TRNSYS program was developed by the solar energy laboratory at the University of Wisconsin in 1975. This program models a building as a series of elements enabling it to access library of pre-defined components or create their own component. TRNSYS is a flexible simulation tool that can simulate the transient performance of thermal energy system (DOE, 2006).

The TRNSYS library of component includes models for many different HVACs systems for more packed HVAC system, enabling users to model for more systems than are available in DOE2. Example components include different types of fan and pumps (including variable speed drive, thermal storage walls, solar thermal collectors, photovoltaic, heat recovery and much more).

This program requires more details for input. TRNSYS is able to compute indoor temperature and relative humidity and allows the user to develop and to run the models of other building component. The TRNSYS is easy to use, widely modeling capabilities and more accurate than DOE2, although it is more complex than DOE2. TRNSY is very expensive for that reason it is not more commonly used in industry.

### **3.3.3 Energy Plus**

Energy Plus is a building simulation program that builds on the most popular features and capabilities of BLAST and DOE 2 (WBDG, 2011). The aim of Energy Plus was to enhance the weaknesses of BLAST and DOE2. Two important goals were to create a modular program to allow new systems to be added and to integrate heat from HVAC system into the building loads calculations (OPEN, 2010).

One of the big advantages of Energy Plus compared to DOE2 and TRNSYS is that Energy Plus models loads and system together. With Energy Plus during the load calculation, the heat going from HVAC equipment is accounted. That can lead load calculation to accuracy of simulation. Energy Plus contains more accurate models compared to other programs, such as a slab and basement program to model heat transfer from the ground. And the big weakness of Energy Plus is that, Energy Plus is more difficult to use than TRNSYS and DOE2 it lacks a GUI.

#### **3.3.4 SUNREL**

SUNREL was developed by the Renewable Energy Laboratory (NREL) to model loads on small building (OPEN, 2011). The newest version is based only on loads calculation with high (?) and it does not calculate energy consumption by the HVAC system accurately.

#### **3.3.5 HOT 2000**

Hot 2000 were developed by Natural Resources Canada to model energy consumption of houses (NRC, 2000). HOT 2000 software uses bin method to predict the annual energy consumption. Bin method is used only for small buildings and private houses not for commercial building energy consumption. HOT 2000 is very easy to use but it presents some problems with accuracy.

To wrap up, these software tools are the core of building energy modeling. Each software tool has its own weaknesses and strengths. Today Energy Plus is the strongest one, and the USA's Department of Energy for Energy efficiency and Renewable Energy is working hard to eliminate the imperfection of Energy plus and updating the new version.

The second and third chapters were the framework for literature review. In the following chapter; we are going to give the overview and the geographic area of the building and collecting building data that could enable us to make the model. In the fourth chapter we are going to enumerate some of the main South African norms of building and energy

supply provided by South Africa National Standard (SANS), South Africa Building Standard (SABS), and the national building regulation.



## **CHAPTER FOUR BUILDING INFORMATION**

### **4.1 Building location**

The building chosen for our model is the student residential building located in Stellenbosch, Western Cape, South Africa. The position of the building is influenced by factors such as the climatic condition and weather in Stellenbosch area. The building construction and power supply complies with the South Africa norms and code of construction and power supply elaborated by South Africa National Standard (SANS). SANS established some codes that classified the group of building according to their utilities and services. Residential buildings belong to the group E1 to E4, H1 to H5.

South Africa is one of the Sub-Saharan countries that is located in the Southern tip of the African continent, and shares the border with Namibia, Zimbabwe and Mozambique. South Africa is bordered by Atlantic Ocean on the West and by the Indian Ocean on the East.

### **4.2 Overview on the building's South Africa norms and codes**

To support the Kyoto protocol, South Africa established the energy policy with objective to: increase the access to affordable energy services, improving energy governance, stimulating economic development, managing energy, and security supply.

In October 2008, SANS 204 for energy efficiency in the building was been published. The Department of Mineral and Energy (DME), and Department of Housing gave some directive of standards. The series of standard SANS 204 have been developed by South Africa Building Standard (SABS), and inserted into the National Building Regulation (NBR) to shape a frame for energy efficiency in the building.

In 2007, the Green Building Council of South Africa (GBCSA) launched the Green Star that is based on assessment of the environmental, performance of the building on the range of issues including energy, water, and material.

Earlier, the DME and Department of Power and Water (DPW) together gave the initiative for retrofitting of the building that the objective was to improve the conservation of water and electricity in public buildings. The DPW is split up into regional offices whereby Cape Town and Johannesburg entered into the contract with private companies. On the other hand the Department of Housing and National Home Building Registration Council

(NHBRC) together established measures of energy saving which have been incorporated in the draft of National Norms and Standards. These measures are based on the ceilings with insulation, internal and external plastering, plastic membrane under floor, sealing the house at ground level and North-facing roof over long.

However, in the same optic of energy efficiency, some local initiatives were noticed such as: Cape Town Solar Hot Water System (SHWS), with objective to install the SHWS to 10% of all private households and 10% of all municipal housing by the year 2010. Johannesburg City Council is motivating and encouraging the designers of new buildings to improve natural ventilations, SHWS, roof insulation, efficient lights, and timer sensors on lights.

The SANS established some norms for power supply security and energy efficiency in the residential buildings such as:

- Residential building shall be supplied at standard voltages 230 V single phase and 230/400V three phases with four wires, and the dead band range +- 10%.
- Occupants should not have access to any “live” cables ( SANS 60529/IEC 60529)
- Earth leakage protection shall be used as an additional protective measure.
- Building installation must have disconnecting devices that will enable the installation to be disconnected for maintenance, testing, fault detection and repair.
- Building distribution board must be protected against corrosion and any point of a distribution board shall not exceed a height of two meter above the floor or walking level or out of reach of infant.
- Bus bar, the current density of copper bus bars shall not exceed  $2A/mm^2$  for current 1600A. The size and the design of the bus bar system shall be appropriate to the prospective short-circuit current that could occur at the supply terminals of the distribution board.
- Building Installation Standard Color Coding shall be respected, i.e. red, yellow, and blue or L1, L2 and L3 shall be used to identify the phase bus bars, green/yellow for the earthling, and black for the neutral bus bar.
- Roof, walls and floor shall be constructed tightly and firmly to minimize air leakage.
- Solar water heating system shall comply with SANS 1307 and the Hot Water System usage shall be minimized, the tank shall be installed with exposed pipes to and from the hot water tank, these pipes must be insulated.

- The HVAC shall comply with the relevant national legislation. The set point temperature of the heating and cooling space shall range between 20<sup>0</sup> Celsius and 24<sup>0</sup> Celsius.

#### **4.2.1 Building envelope and South Africa norms**

Building envelope is the physical separator between the indoor and exterior environment of a building (Kadlubowski & Yates, 2009). As explained above the building envelope is the biggest factor of heating and cooling loads, therefore several strategies have been applied to improve the R-value that could decrease U-value. U-value is a measure of the heat transmission through a building envelope (thermal transmittance), while R-value is a thermal resistance of a component.

The South African energy police emphasized that the new norms established by SANS and SABS for building envelope concerning U-value, R-value and solar heat gain coefficient (SHGC). According to SANS, the building envelope and any opening such as windows and doors in the external fabric shall be constructed to minimize air leakage. Caulking or adding skirting, architraves, or cornices methods maybe applied for building sealing.

In the optic to overcome the SHGC problems, SANS highlighted that the building construction should be compact with the rooms that are most used and the major Areas of glazing placed on the northern side of the building to allow solar heat to penetrate the space during winter season.

In our work, we did point out some major recent norms and codes that SANS and SABS established in 2011 regarding the building envelope, we are going to enumerate some of them, such as:

Buildings shall use insulation glazing

- The total U-values and Solar Heat Gain Coefficient (SHGC) shall be assessed for the combined effect of the glass and frame. The measurement shall comply with (NFRC).
- A roof assembly shall achieve the minimum total R-value specified in table 4.1 for the direction of heat flow according to the climate zone.
- The metal sheeting type of roofing assembly construction shall achieve the minimum total R-value as specified in table 4.2.
- U-value and SHGC values, in accordance with table (4.3 worse-case glazing), shall be used unless these values are supplied by the glazing manufactures as

verified in accordance with ASTM C 1199 and ISO 9050 for U-values, and given in NFRC 100 for SHGC values.

- Floor, the under floor heating system shall be insulated underneath the slab with insulation that has a minimum R-value.
- Non masonry wall shall achieve a minimum total R-value
- All fenestration air infiltration shall be in accordance with SANS 613
- A seal to restrict air leakage shall be fitted to each edge of an external door and other opening components.

**Table 4.1: Minimum total R-value of roof assemblies (SANS, 2011)**

1	2	3	4	5	6
<b>Climatic zones</b>					
1	2	3	4	5	6
<b>Minimum required total R-value</b>					
<i>m<sup>2</sup>·K/W</i>					
3,7	3,2	2,7	3,7	2,7	3,5
<b>Direction of heat flow</b>					
Up	Up	Down and up	Up	Down	Up

**Table 4.2: metal sheeting roof assemblies (SANS, 2011)**

1	2	3	4	5	6	7
<b>Description</b>	<b>Climatic zones</b>					
	1	2	3	4	5	6
Direction of heat flow	Up	Up	Down and up	Up	Down	Up
<i>R</i> -value ( <i>m<sup>2</sup>·K/W</i> ) of roof covering material	0,35				0,48	0,35
<i>R</i> -value ( <i>m<sup>2</sup>·K/W</i> ) of ceiling	0,05					
Added <i>R</i> -value of insulation	3,30	2,80	2,30	3,30	2,17	2,8

**Table 4.3 Worst-case whole glazing element performance values (SANS, 2011)**

1	2	3	4	5
Glass description	Performance values			
	Aluminium/Steel framing		Timber/PVCu/Aluminium thermal break framing	
	Total U-value W/m <sup>2</sup> ·K	SHGC	Total U-value W/m <sup>2</sup> ·K	SHGC
Single – Clear	7,9	0,81	5,6	0,77
Single – Tinted	7,9	0,69	5,6	0,65
Single – Low E <sup>a</sup>	5,73	0,66	4,06	0,63
Clear double <sup>b</sup> (3/6/3)	4,23	0,72	3,0	0,68
Tinted double <sup>b</sup>	4,23	0,59	3,00	0,56
Clear double <sup>b</sup> low E <sup>a</sup>	3,40	0,66	2,41	0,62
Tinted double <sup>b</sup> low E <sup>b</sup>	3,40	0,54	2,41	0,51

The following part will describe the weather for the Western Cape precisely Stellenbosch where the building is located.

#### 4.2.2 Climate and weather data

The climate in South Africa ranges from desert and semi-desert in the north-west of the country to Sub-tropical in the eastern coastline. The rainy season for most of the country is in the summer. In the Western Cape, rains come in the winter, and part of the Eastern Cape, (Portfolio, 2014). Figure 4.1 depicts climatic zone map of South Africa and table 4.4 shows the locations of big towns and provinces in such zones.

Stellenbosch is located in Western Cape and is influenced by the Western Cape climatic conditions. The Western Cape is located in (zone 4) as illustrated by table 4.4 which means Stellenbosch is located in (Zone 4). The Western Cape is crossed by Mediterranean climate. Summer season is warm and dry with high intensity of sunshine, and the temperature ranges between 17<sup>o</sup>C and 40<sup>o</sup>C. Winter season is cold and wet; the temperature ranges between 3 <sup>o</sup>C to 10<sup>o</sup>C. Figure 4.2 describes the monthly weather data of Western Cape.

South Africa is one of the countries that experience a huge amount sun shine. The sun shines throughout the year, the peak intensity of the sun reaches 1KW and the average

solar radiation level ranges between 4,5 KW to 6KW/m<sup>2</sup> per day. South Africa is in good position to use solar energy as a renewable source of energy for others alternatives.

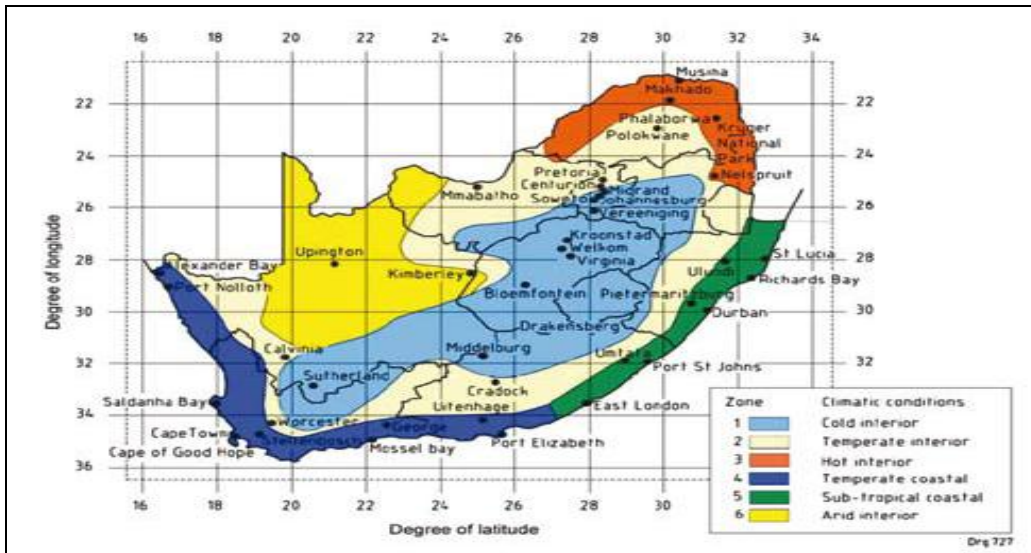


Figure 4.1:Climatic zones of South Africa (SANS, 2012)

Table 4.4 Location of South Africa big Towns and Provinces in such zone

Zone	Description	Major centre
1	Cold interior	Johannesburg, Bloemfontein
2	Temperate interior	Pretoria, Polokwane
3	Hot interior	Makhado, Nelspruit
4	Temperate coastal	Cape Town, Port Elizabeth
5	Sub-tropical coastal	East London, Durban, Richards Bay
6	Arid interior	Upington, Kimberley

### 4.3 Building presentation

In order to model the energy for our building we will describe the characteristics and give details of the building that could enable us to make an accurate model. Table 4.5 and 4.6 demonstrate the building information that could be used as input for the model. According to the SANS norms and code, this building belongs to the group H3 and is influenced by zone 4 climatic conditions.

**Table 4.5: Building information**

Building information( data)				
Type of building	H3 ( Residential)			
Building location and outdoor conditions	Location	Stellenbosch/W Cape		
		Climatic zone	Zone 4	
	Latitude	33,9 <sup>0</sup> South		
	Longitude	18.53 <sup>0</sup> East		
	Elevation			
	Outdoor conditions temperature	Cooling temperature	40 <sup>0</sup> C db	33 <sup>0</sup> C wb
		Heating temperature	7 <sup>0</sup> C	
	Volumetric air flow rate	4m/s		
	Humidity ratio	Wi=0.0093KgW/Kgda		
		Wo=0.0159KgW/Kgda		
Indoor design conditions	Indoor comfortable or designed temperature and relative humidity	Cooling	23 <sup>0</sup> C 50%RH	
		Heating	21 <sup>0</sup> C 30% RH	
Building Envelope	Windows with single glass plat without internal shading thickness 3m	U-value	5.7	
		R-value	0.173	
		SGHC	0.13	
	External walls	U-value	0.52	
		R-value	1.9	
	Roof Assembly	U-value	0.27	
		R-value	3.7	
	Ground-slabs	U-value	1	
		R-value	1	

**Table 4.6: Building Size and form**

<b>Building size</b>		
<b>External walls</b>	<b>North</b>	<b>336m<sup>2</sup></b>
	<b>East</b>	<b>67.2m<sup>2</sup></b>
	<b>West</b>	<b>67.2m<sup>2</sup></b>
	<b>South</b>	<b>336m<sup>2</sup></b>
<b>Windows</b>	<b>81m<sup>2</sup></b>	
<b>Roof area</b>	<b>312 m<sup>2</sup></b>	
<b>Floors area</b>	<b>312 m<sup>2</sup></b>	
<b>Building total walls area</b>	<b>709 m<sup>2</sup></b>	
<b>Building capacity</b>	<b>30 People/ two per apartment</b>	
<b>Building form</b>	<b>Rectangular</b>	

The U value and R value standards of the building envelop established by SANS, are based on the climatic zone map illustrated by figure 4.1. According to SANS, in the climatic zone 4 in which is located our building, wall shall achieve minimum R-value  $1.9\text{m}^2.\text{K}/\text{W}$ , a roof assembly 3.7, a floor minimum value of R required by SANS is 1, and for the window with Timber/PV Cu/Aluminum framing U-value required is  $5.6\text{ W}/\text{m}^2\text{K}$  single-clear and  $3\text{ W}/\text{m}^2.\text{K}$  double clear.

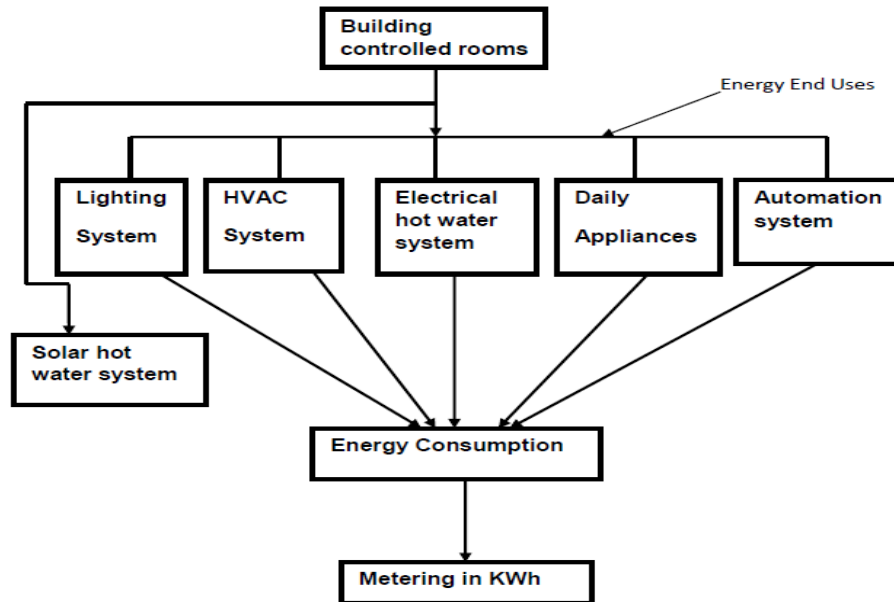
The indoor design conditions were normalized by ASHAREA, which are reliable, comfortable, and convenient to the building occupant's health. That is to say  $23^{\circ}$  Celsius and 50% Relative Humidity for cooling in the summer season, and  $21^{\circ}$  Celsius and 30% Relative Humidity for heating during the winter season.

Table 4.5 and 4.6 describe information of the building which could help as for the modeling and simulation. According to the building information, our building complies with SANS requirements regarding the building envelope and the energy supply.



## 4.4 Building systems structure

### 4.4.1 Building energy End Uses and structure of automation system in the building



**Figure 4.2: Building energy end uses for residential building in South Africa**

The block diagram Figure 4.3 describes the repartition of energy end uses in the building from the energy supply, over the automation system (control system) to HVAC system, lighting system, hot water system and daily appliances. The block building represents residential building in which the energy is used. Block energy consumption represents the total energy used in kilowatt-hours by the end users.

The block diagrams Figure 4.4 represents the hierarchy structure of automation system for energy management in the building, in which all devices are connected with each other through buses. Computer workstation (Human Interface Device) is placed on the top that serves to program the building systems according the energy management, to display graphically the behaviours and instability of the systems, to display and locate faults, errors and failures that occur in the systems.

Direct Digital Controller (DDC) is used as controllers for energy end uses and normally all the DDCs must be mounted in a control cabinet.

DDC1 serve to control and switching on/off lighting system by mean of actuators 1 according the information got from S1. S1 represent detectors that control the motions in the control rooms and outdoor's daylight/darkness.

DDC2 serves to control, to regulate HVAC system and to enable the whole system to operate automatically. S2 represent sensors that measure the temperature in the control rooms and send information to DDC2. DDC2 activates actuators, actuators 2 open and close valves and ventilation flaps to reach the set- point temperature desired by the users or shut on/off HVAC system when they are needed or not.

DDC3 serves to control hot water systems; it switches on/off electrical geyser (hot water system) through actuators 3 at specific times and according to the availability of hot water from the solar hot water system. S3 represent sensors that measure the temperature of water from the electrical geyser tanks and solar geyser tanks to send the message to DDC3.

DDC4 serves for energy management and security; it powers down the energy supply through actuators when unsteadiness occurs in the systems or if there occurs unsecure problems such as fire, smoke and others problems. S4 represent fire and smoke detectors linked to alarms. DDCS 4 serves as well to shut down selected large loads if the demand is about to exceed the set point peak load according the period.

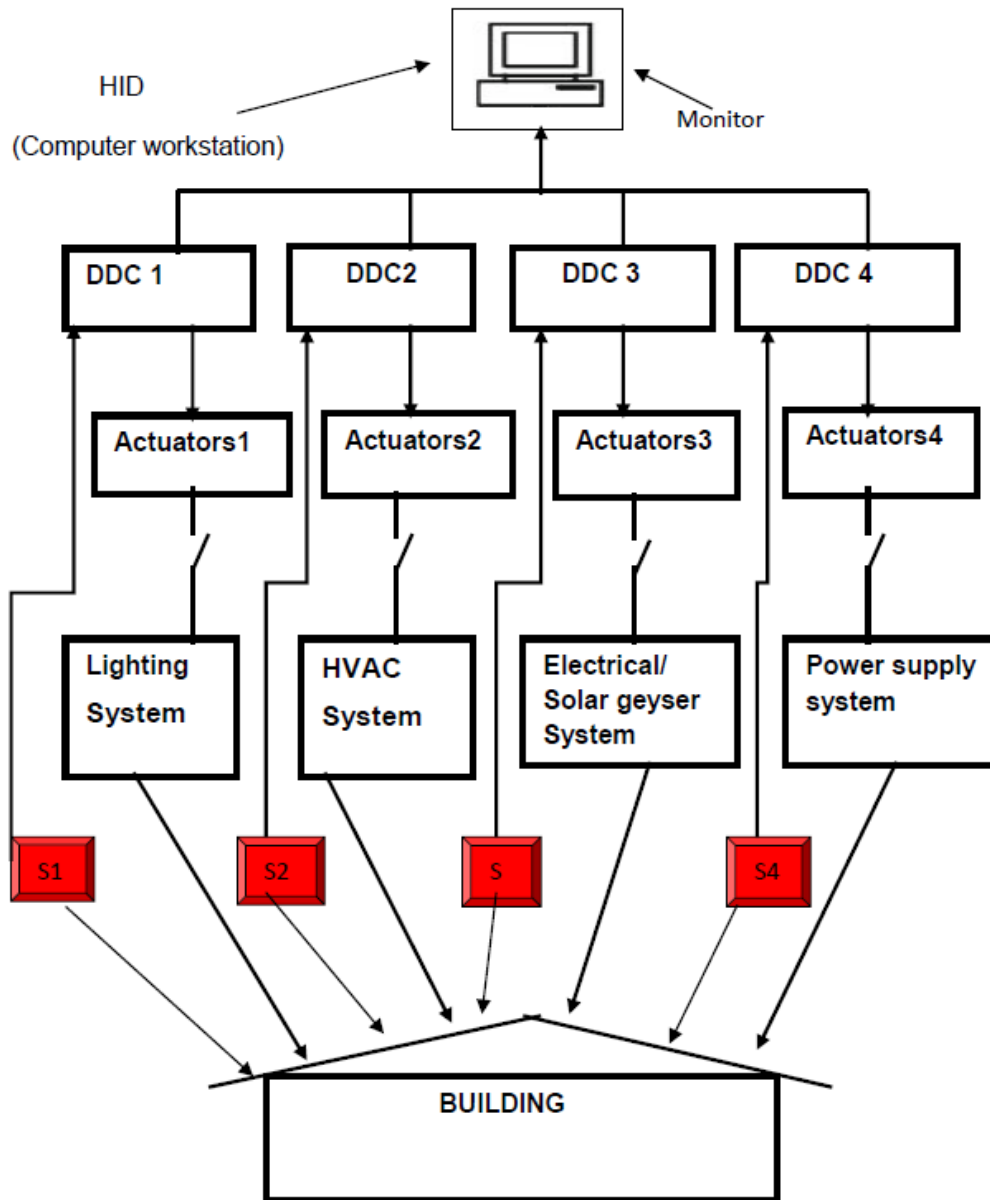


Figure 4.3: Structure of automation system in the building

#### 4.4.2 Electrical plugs loads

In residential buildings, electrical plugs loads are set up for daily appliances such as: cooking, washing, cleaning, and entertaining devices, refrigeration system and forth. Those daily appliances are used intermittently as facilities to make the lives of building's occupants easy and more comfortable. These facilities are out of automation system control and are used according to the schedules of building's occupants. Some of appliances such as: TV, oven, kettle, toaster, microwave and computer are used every day intermittently for the shot duration. Other appliances such as: vacuum cleaner, floor polisher, washing machine, tumble drier, frying pan and printer are used once a week sometimes once in two weeks. Regarding the fridge, it is on twenty-four hours with an automatic break of one to two hours.

According to the occupants of the building (students), during the weekdays they use most of appliances in the morning from 06:00 to 09:00 and in the evening from 18:00 to 21:00, and during the weekends and public holidays from 07:00 to 09:00, from 11:00 to 14:00, and from 18:00 to 21:00. Regarding washing and cleaning appliances, these are mostly used only during the weekends, especially on Saturdays.

Table 4.7 describes data of energy consumption for one apartment. Column one on the left side enumerates appliances mostly used by most of residents in the building, the second column denotes the wattage ratio (WR) measured in kilowatt for each appliance, the third column expresses total daily operating period(DOP) of each appliance measured per hour, the fourth column expresses total monthly operating period(MOP) measured per hour, the fifth column presents the monthly total energy consumption for each appliance(MEC) measured in kilowatt-hour, sixth column expresses total yearly operating period(YOP) , seventh column denotes the nominal total energy consumed by each appliances per year(YEC), and eighth column expresses the average total energy consumed by each appliance per year(Av-YEC) measured per kilowatt-hour.

The values illustrated by the seventh column are called nominal, because some of those values are not accurate compared to real life and our experimentations. These values are obtained by calculations from the electrical power of appliance, while some appliances are not using their maximal electrical power to work. Let us analyze the fridge, the fridge uses maximal electrical power only if the load reaches the peak level, but for residential applications, the fridge uses only the half or 2/3 of its maximal electrical power, because fridge is not often filled completely. Moreover the fridge uses

the maximal power during summer and less power in winter, whereas the kettle, oven, heater and geyser use maximal power in cold season and minimal power in hot season.

**Table 4.7: Overview of yearly average energy consumption by daily appliances in the residential building**

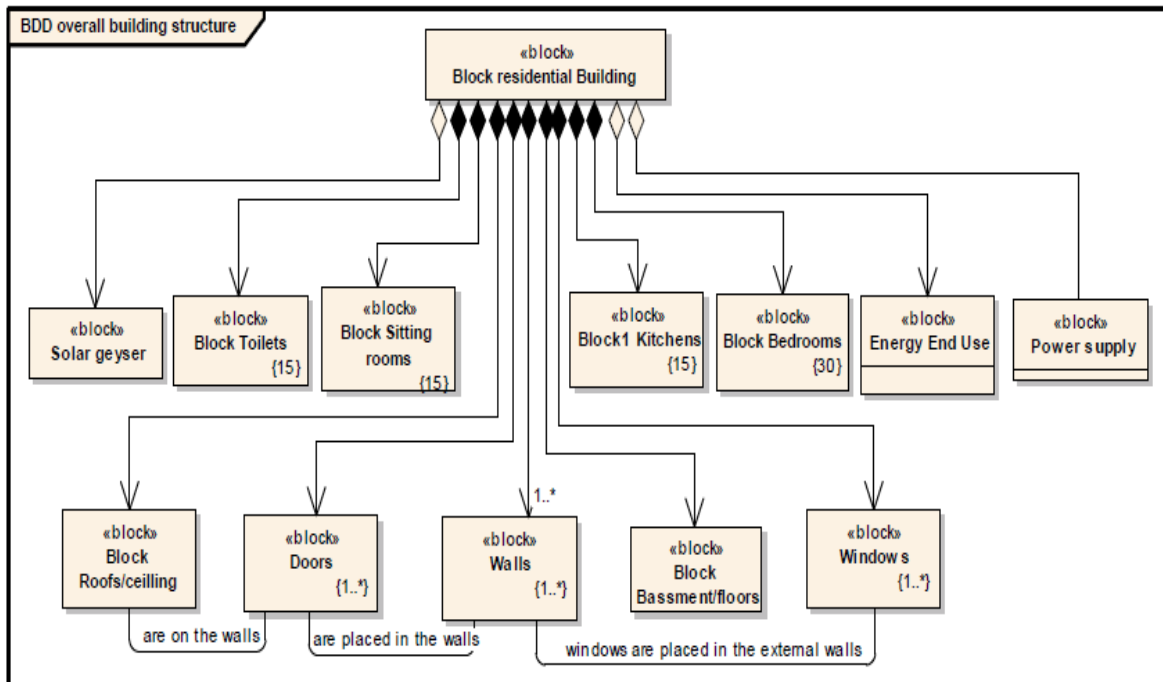
<b>Appliances</b>	<b>WR in [KW]</b>	<b>DOP in [h]</b>	<b>MOP in [h]</b>	<b>MEC in [KWh]</b>	<b>YOP in [h]</b>	<b>YEC in [KWh]</b>	<b>AvYEC [KWh]</b>
<b>Fridge</b>	<b>0.6</b>	<b>20</b>	<b>600</b>	<b>360</b>	<b>7200</b>	<b>4320</b>	<b>2160</b>
<b>TV</b>	<b>0.1</b>	<b>4</b>	<b>120</b>	<b>12</b>	<b>1440</b>	<b>144</b>	<b>100</b>
<b>Hi Fi</b>	<b>0.1</b>	<b>6</b>	<b>180</b>	<b>18</b>	<b>2160</b>	<b>216</b>	<b>180</b>
<b>Vacuum</b>	<b>0.6</b>	<b>–</b>	<b>4</b>	<b>2.4</b>	<b>4.8</b>	<b>28.8</b>	<b>25</b>
<b>Floor Polisher</b>	<b>0.4</b>	<b>–</b>	<b>4</b>	<b>1.6</b>	<b>48</b>	<b>19.2</b>	<b>16</b>
<b>Washing machine</b>	<b>2</b>	<b>–</b>	<b>8</b>	<b>16</b>	<b>96</b>	<b>192</b>	<b>150</b>
<b>Tumble drier</b>	<b>3</b>	<b>–</b>	<b>8</b>	<b>24</b>	<b>96</b>	<b>288</b>	<b>250</b>
<b>Oven</b>	<b>3</b>	<b>4</b>	<b>120</b>	<b>360</b>	<b>1440</b>	<b>4320</b>	<b>4000</b>
<b>Microwave</b>	<b>1.5</b>	<b>0.5</b>	<b>15</b>	<b>22.5</b>	<b>180</b>	<b>270</b>	<b>250</b>
<b>Kettle</b>	<b>2</b>	<b>0.5</b>	<b>15</b>	<b>30</b>	<b>180</b>	<b>360</b>	<b>330</b>
<b>Toaster</b>	<b>1.1</b>	<b>0.2</b>	<b>6</b>	<b>6.6</b>	<b>72</b>	<b>79.2</b>	<b>70</b>
<b>Frying pan</b>	<b>1.5</b>	<b>0.5</b>	<b>15</b>	<b>22.5</b>	<b>180</b>	<b>270</b>	<b>250</b>
<b>Computer</b>	<b>0.2</b>	<b>6</b>	<b>180</b>	<b>36</b>	<b>2160</b>	<b>432</b>	<b>400</b>
<b>Total yearly energy consumption of all daily household appliances for one apartment regrouping two occupants</b>						<b>10939.2</b>	<b>8181</b>

## CHAPTER FIVE BUILDING ENERGY MODELING AND SIMULATIONS

### 5.1 Building and systems structure

In South Africa, some residential buildings are made up of apartments commonly called “flats” and most of these flats are made up of one, two or three bedrooms, kitchen and sitting-room more often in mono-block, toilet and bathroom in mono-block as well.

Our building is composed of apartments (flats); each flat has two bedrooms, one kitchen, one sitting-room and one bathroom. The building chosen for our model has 15 flats with 5 flats each on the ground floor, first floor and second floor.

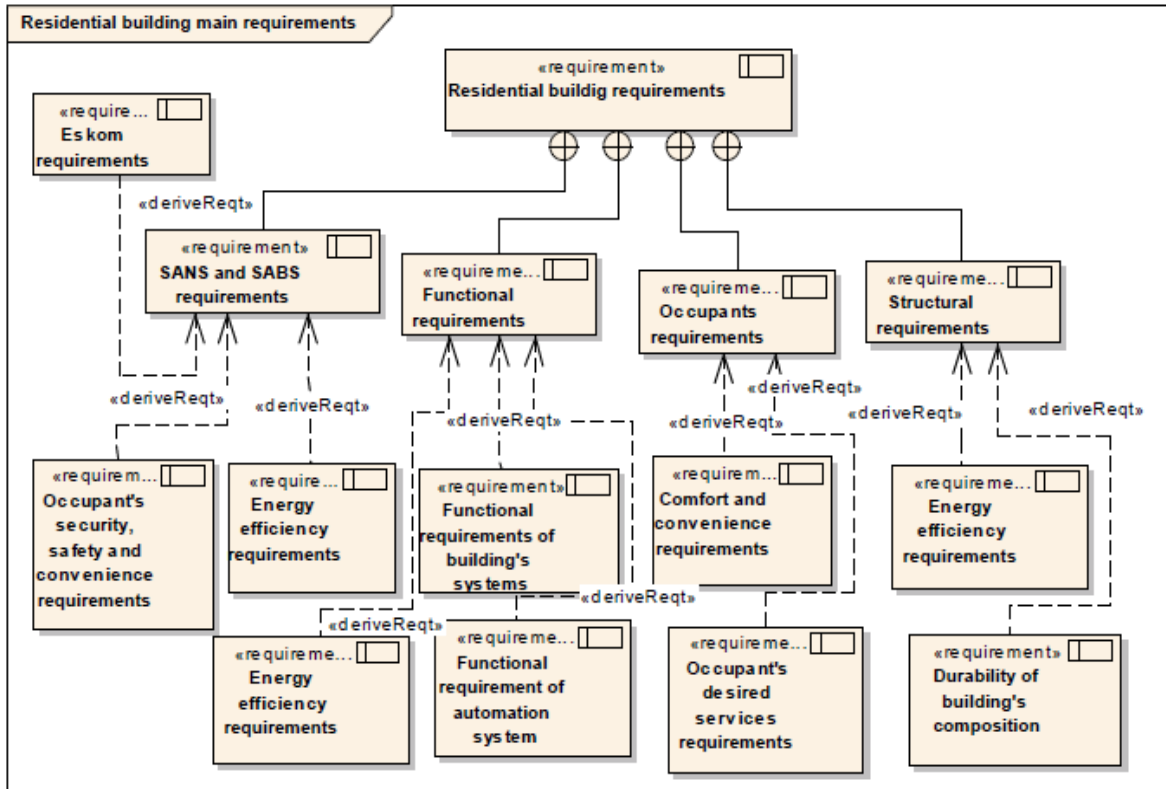


**Figure 5.1: Block Definition Diagram for the overall residential building**

To simplify the model, we made a break down all of the flats in one block, and the building will be considered as a simple box made-up with walls, roofs, ceiling, windows, doors basements and floors.

Figure 5.1 is a block definition diagram (BDD) of the overall building structure that illustrates the overview of the building structure. The BDD in Figure 5.1 describes the building skin such as; (walls, windows, ceiling, doors, roof, basement and floors), the building zones (toilet, sitting room, kitchen and bedrooms), and the building technology

or energy end uses in the building such as; lighting system, HVAC system, hot water system, automation system and daily appliances. The number below each zone block represents the amount of zones for the complete building.



**Figure 5.2: Requirement diagram for residential building in South Africa that describe the structures of building requirements to meet energy efficiency**

Figure 5.2 is the requirements diagram of residential building. This requirements diagram enumerates the structure of requirements that our building shall comply with to provide safety, security, comfort, and convenience to building's occupants at low energy consumption. This requirement diagram is based on the requirements of:

- SANS, SABS and South Africa national energy supplier in order to respect the South African norms and standards that are based on energy efficiency, safety, security and convenience of the users of buildings.
- The building's occupants in order to satisfy their needs to be in a comfortable environment.

- Structure of the building to respect and satisfy the requirements of both SANS / SABS and the occupants of the building.



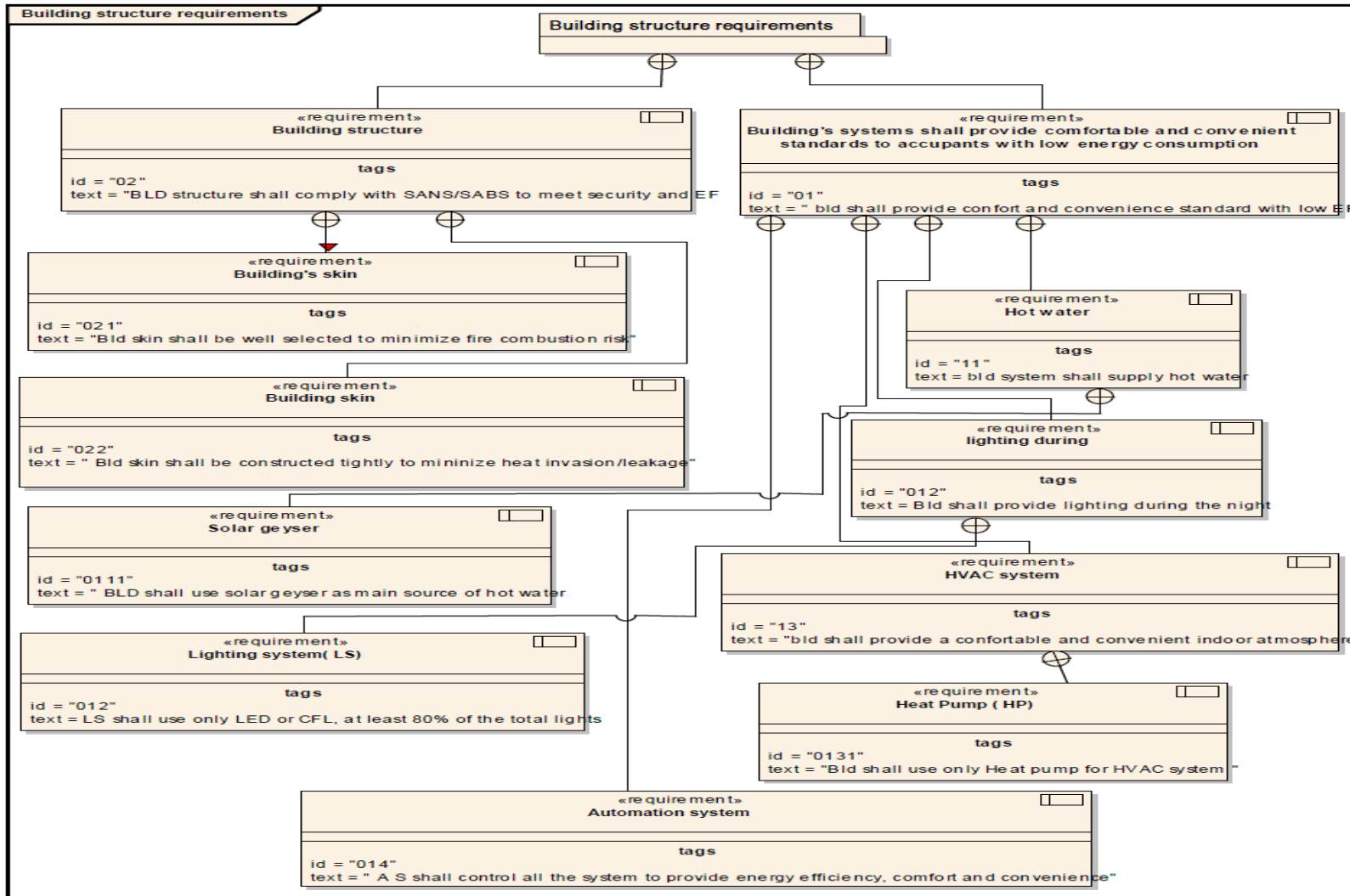


Figure 5.3: Requirements diagram for building's structure that define the main requirement of energy efficiency

Figure 5.3 is the requirements diagram that defines the requirements enumerated by the requirements diagram Figure 5.2, and describes the requirements of the building's structure. The first block child 02 and its derivatives blocks in the requirements diagram define the requirement of SANS and SABS that the building shall comply with. We did not enumerate all those SANS requirements in the requirement diagram because it is long list consist of several pages. These norms and requirements can be obtained at SABS standards division all versions.

According SANS and SABS, the building envelope shall comply with SANS norms to protect the building against fire, combustion, accident and collapsing of the building. Glazing of the building shall comply with all requirements of SANS 613, the building envelope must satisfy all the requirements for compliance with fire protection SANS 101775, the building envelope shall be constructed compactly to minimize heat invasion/leakage and comply with SANS to meet the minimum U-value and R-value requirements to mitigate heating and cooling loads. Piping system and ducts of hot water systems and HVAC systems shall be insulated to minimize heat evasion.

The second block child 01 with its derivative blocks on the right side in the requirements diagram define the requirements of the building to make occupants' lives more comfortable and convenient by using low consumption of energy. These requirements are the main requirements of the building such as: block 011 the building's system must provide hot water for bathing, dishes and cleaning by using solar geysers as the main source of energy and electrical geyser as backup source, block 012 buildings system must provide lighting by using CFL and LED bulb, block 013 the buildings system must provide the indoor air quality and comfortable temperature in the controlled rooms of the building by using heat pump, and block 014 'the building systems must be controlled by automation system to enable energy management. These are in concise the main requirements that the building must comply with to provide safety, security, convenience and comfort to the occupants with low energy consumption. In the following point, we are going to define and model the energy end use of the building.

Figure 54 is the domain model diagram that illustrates the structure of the model by enumerating elements represented by blocks. Energy end use represents the energy end use of the building that are controlled by automation system to provide comfort and

convenience to the occupants of building, at the same time automation system manages energy provided by power supply. SANS/SABS establish rules and norms of the building structure and energy end use, metering measures the energy consumed by energy end use, solar geyser supplies hot water to the building, weather conditions exchange heat with the building and supply solar geyser with solar heat energy and the building is hinge of the modeling.

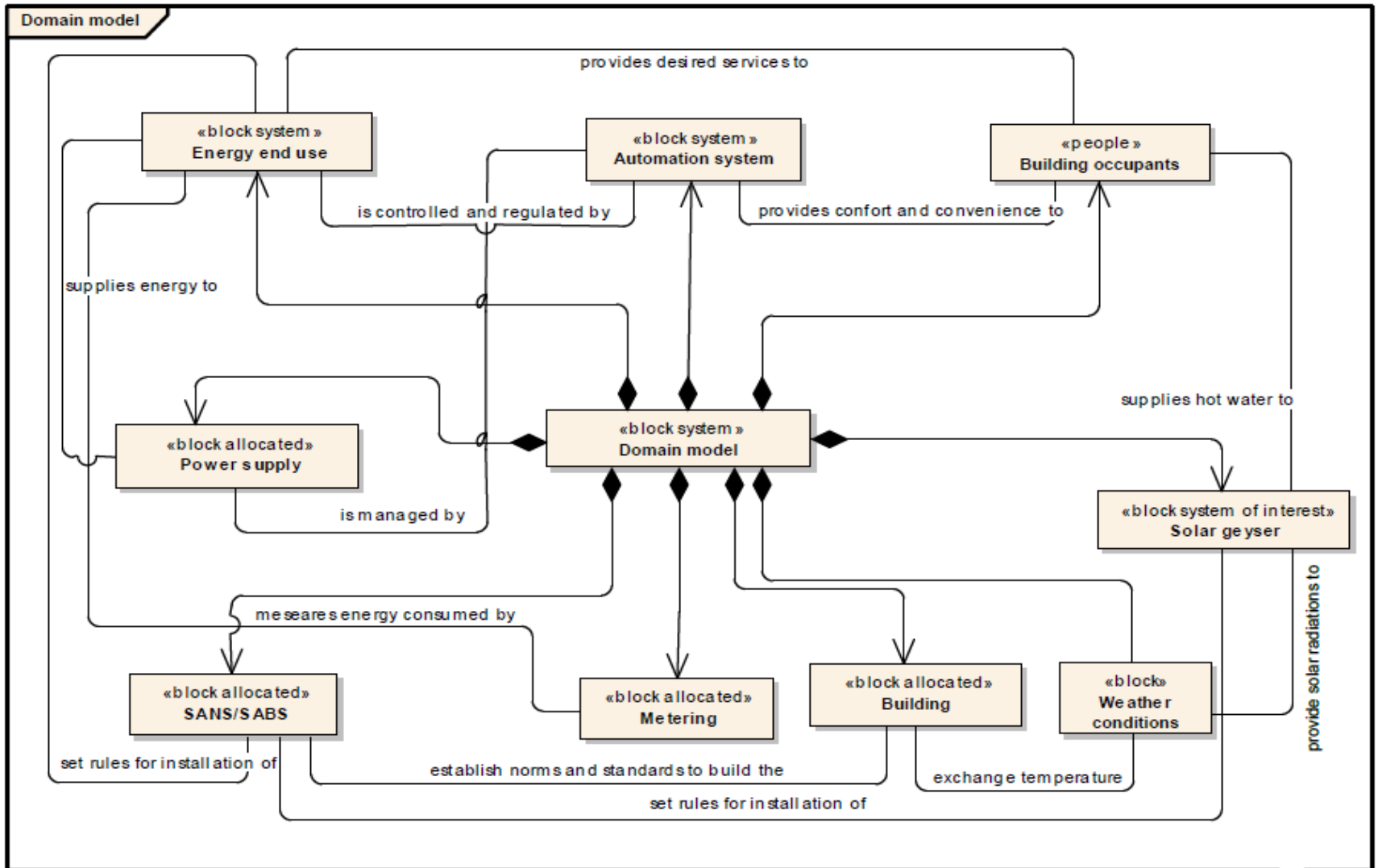


Figure 5.4: Domain Model

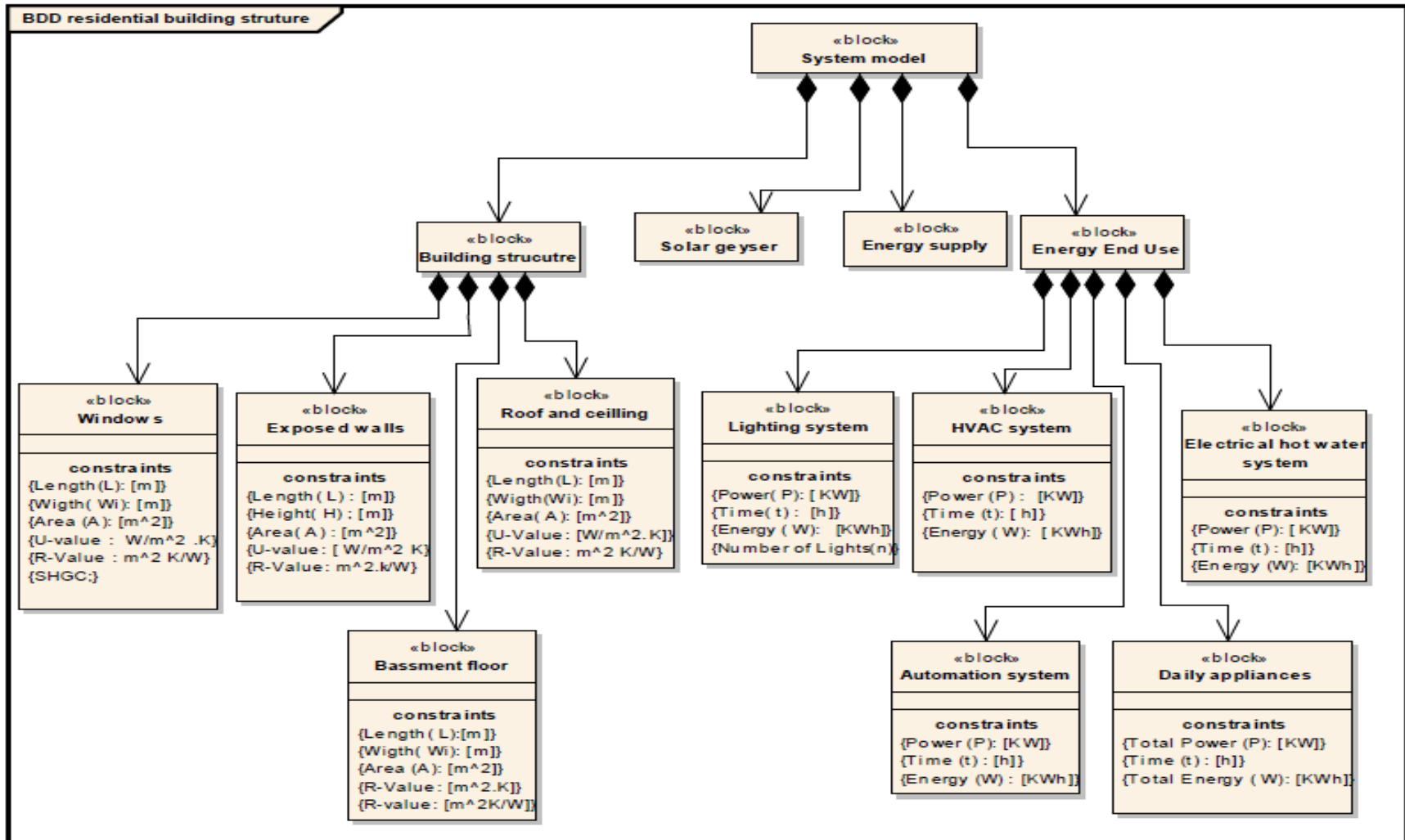


Figure 5.5: Block definition Diagram for building's structure

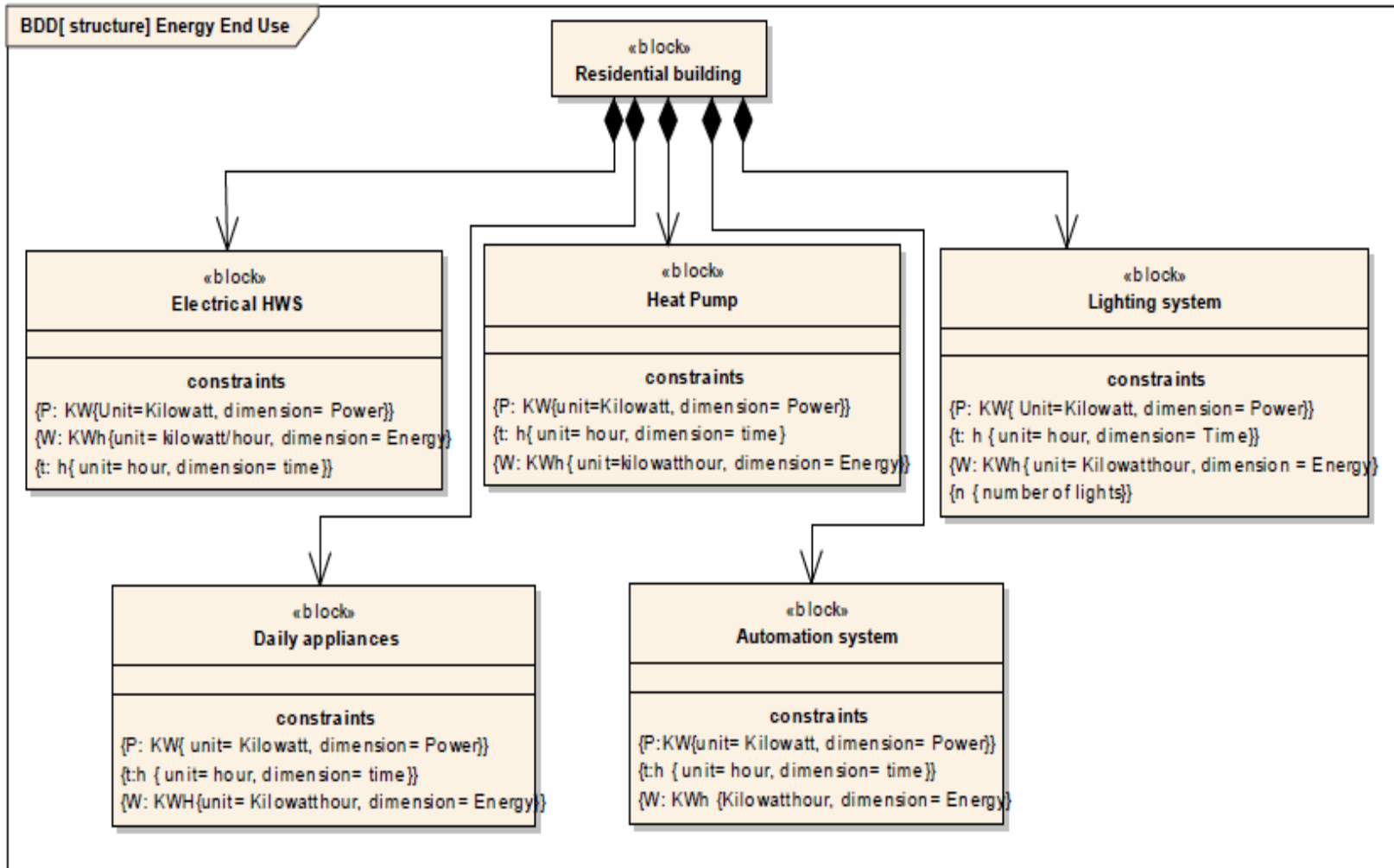


Figure 5.6: Block Definition Diagram of Energy End Use in the residential building

### 5.1.1 Residential building End Uses

Energy End Uses of the building are systems that provide more desired services to the building occupants per unit of energy, these systems transform unit of electrical energy supplied by the source to other desired energies or works by the building's occupants.

Energy End Uses is made-up and set-up for the building to satisfy the main requirements of the building described in the requirement diagrams Figure 5.3. Figure 5.6 is Block definition Diagram that describes Energy End-Use of the building such as: HVAC system, lighting system, Hot Water system, Automation system and appliances. These are the devices that consume electrical energy in the residential building.

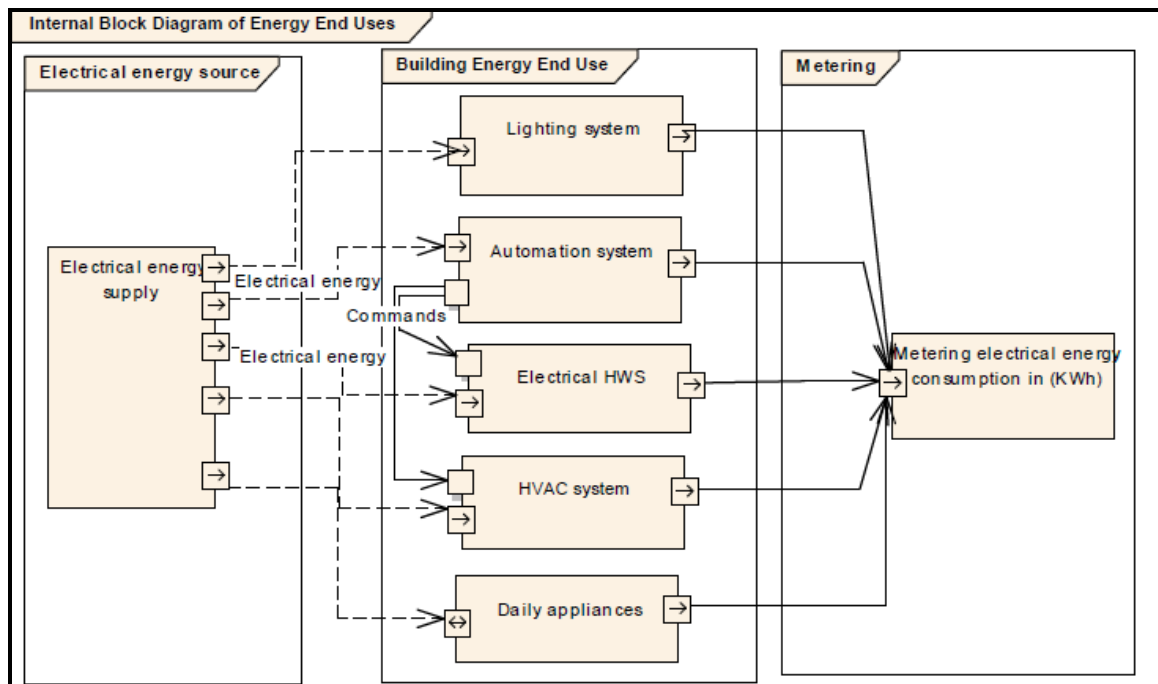


Figure 5.7: Internal Block Diagram of Energy end Uses

#### 5.1.1.1 Automation system

The energy end use automation system facilitates the execution of the main requirements for the control of the building's systems to work adequately and for energy management. Figure 5.8 is a requirement diagram of the automation system that defines the functional requirements of the building's systems to optimize energy management and provide comfort, convenience and security to the building's occupants as block parent mentioned in the requirement diagram. These requirements are used as the input

of the automation system's program, the building systems must work according to these requirements.

The first block child defines kind of bulbs (lights) that lighting system must use to mitigate the consumption of energy by the lighting system. CFL and LED are the more efficient lights and very competitive to new technology. Buildings require at least 80% of the total lights to use CFL and LED.

The second block child defines the requirements of energy management by the automation system. The automation system must limit the peak energy demand to avoid the overconsumption of energy. The automation system is required to shut down power supply if the systems do not respect the main requirements of the systems such as: the use of CFL or LED, the USE of heat pump for HVAC system, the use in parallel solar geyser and electrical geyser. The automation system is required to shut down power supply and activating alarms in case of fire and combustion.

The third block child defines that the automation system is required to control the hot water system; the automation system must shut on/off electrical geyser according to the scheduled time, and shut off the electrical geyser when the solar geyser can provide hot water.

The fourth block child defines that the automation system is required to adjust the temperature in the controlled rooms. The building occupants shall be able to control the temperature. The requirements described in the diagram are main requirements for the automation system.

Figure 5.9 is the Block Definition Diagram (BDD) of the automation system that describes different components of automation system and the relation to it. In the block definition diagram, block automation system is represented as block parent, and blocks child represent automation systems parts, and related systems. Block child DDCs that represents the DDCs of automation system, contains blocks child as well such: detectors, actuators, transducers, sensors, timer and valves. The second block child is workstation computer, and other blocks child represent the related if the automation system such as: HVAC system, Power supply system, solar hot water system, lighting system and electrical hot water system.



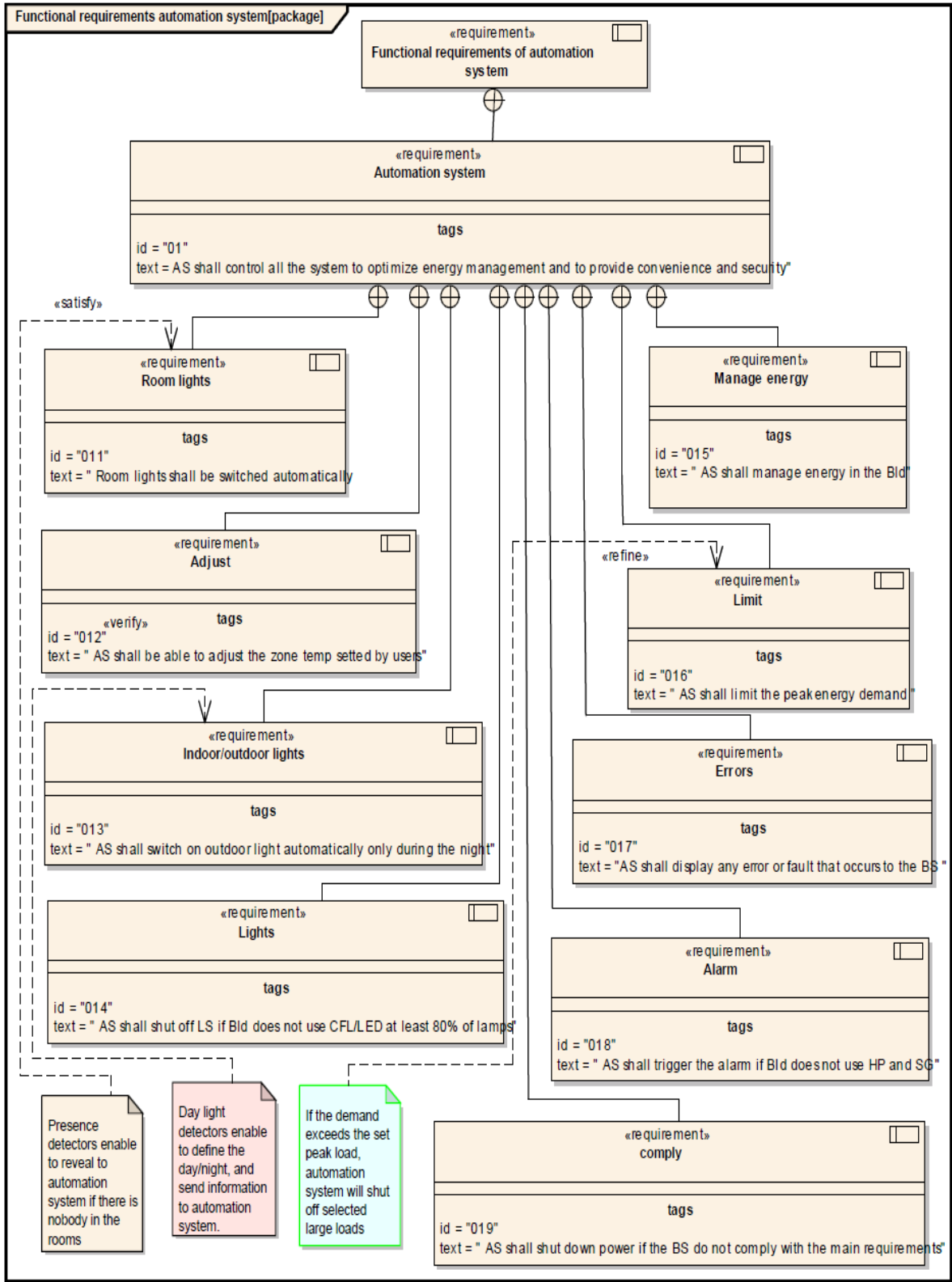
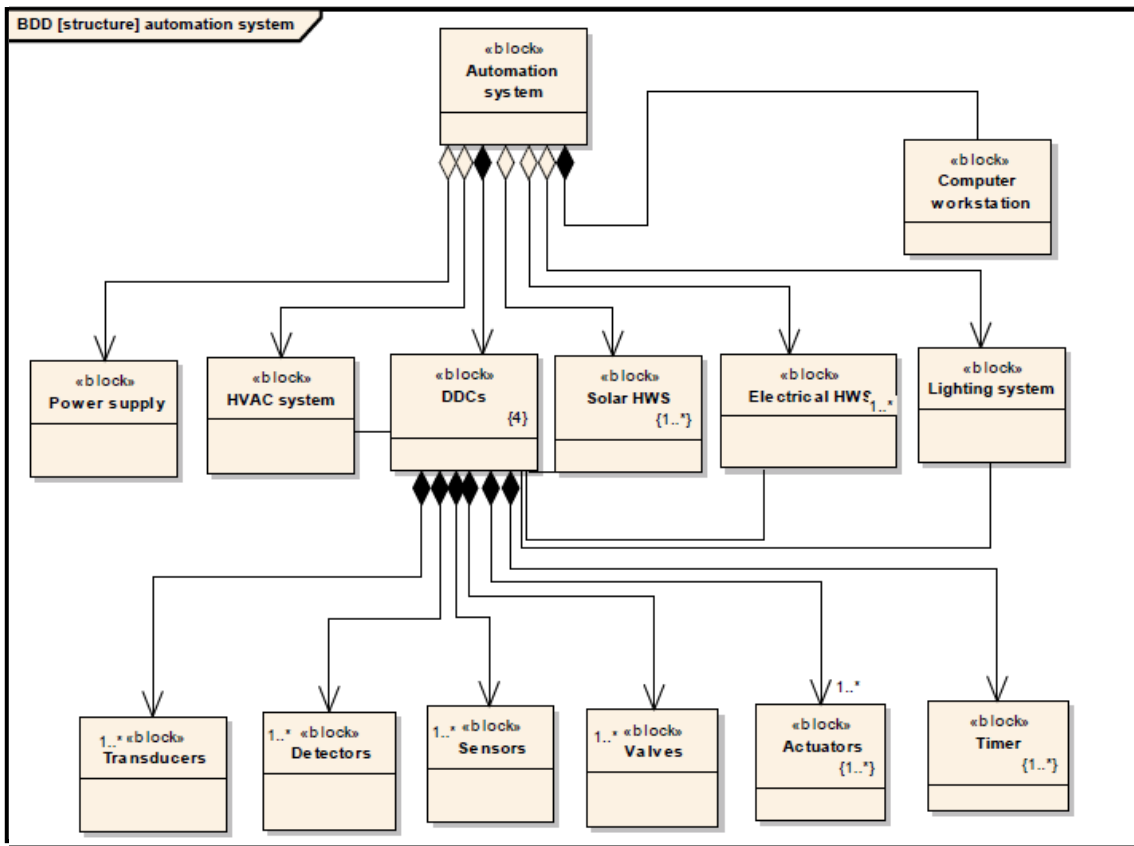


Figure 5.8: Requirements diagram for automation system

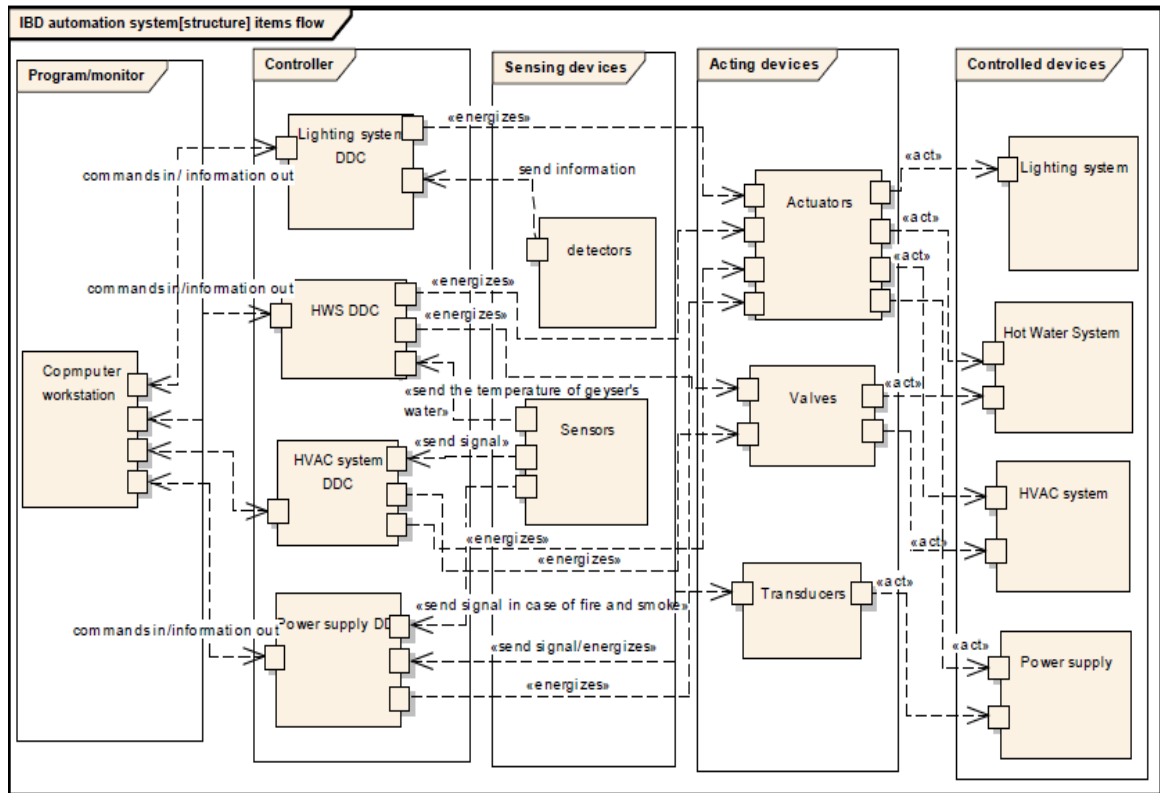
Figure 5.10 is the internal block diagram of automation system that describes the automation system parts represented by blocks, and each block contains flow ports that are connected to their related systems to allow the flow of energy, information, signals and commands. Block controller regroups DDCs of the system, DDCs are the central stations (Hub) of the automation system, and the automation system devices are connected with each other through DDCs. Block controller is the decision element that carries out the standards stored in the program. DDCs receive analog information from sensing elements, transform them to digital data and compare them with the standard data programmed by the computer station. If there are some discrepancies, DDCs energize and command the appropriate actuators to stabilize the concerned system. Each building system has its own DDC which they are dealing with.



**Figure 5.9: Block Definition Diagram automation system's structure**

Block sensing devices regroups sensors, transducers that collect data such as temperature, humidity, motion, daylight, light level, motion, fire, smoke level or state (such as on, off, open, closed and others) from the controlled zones and send them to DDCs through buses.

Block acting devices regroups actuators and transducers that receive commands from DDCs and act on slaves devices to perform the controlled devices. Slave devices may consist of valves, switches, circuit breakers to control the flow of energy, water air, and others matter. Block controlled devices regroups the systems of the building such as lighting system, Heating ventilation and air condition system, hot water system, and power supply that are controlled by automation system.



**Figure 5.10: Internal Block Diagram of automation system and connectors describes the flow of items in the system**

### 5.1.1.2 Lighting system

Lighting system in the residential building is required to work efficiently in a convenient and secure way to reach our targets. That is why requirements were established, and the building must comply with requirements.

Figure 5.11 is the requirement diagram of lighting system that describes the requirements of lighting system. The block parent in the requirements diagram of lighting system provides requirements, which enable the lighting system to operate adequately and efficiently.

The first block child on the left side is the requirement emphasized previously by the main building requirements diagram to optimize the consumption of energy by lighting system.

The second block child and its derivative blocks on the left side in the requirement diagram describe the requirement according to SANS and SABS which lighting system must comply with. SANS 10400/10399-1 established some standards and norms for the sake of building occupants. These norms are based on security, perfect light and other good reasons. The first derivative block of SANS requirements “light switches shall be horizontal aligned with door handles” is established to allowing disabled occupants to be able to switch on/off lights manually. The second derivative block of SANS requirements emphasizes the level of light illumination to perform the eyesight of occupants.

The third block child requires that lighting system must be controlled by automation system. Indoor lights must be switched on/off manually or automatically to avoid untimely use of lights, and outdoor lights must be on during the night and off during the day, these states are controlled by day light detectors for outdoor lights and presence detectors for indoor lights.

The fourth block child defines the main requirements “Lighting system shall provide lighting to the indoor and outdoor of building” as we said in the previous chapter that “light is an indispensable part of our lives, because the light is the mainstay of eye and eyesight.

Figure 5.12 is the block definition diagram of lighting system that defines the main components of lighting system and its relevant devices represented by blocks. Indoor lights are made up with 75 LED or CFL lamps. Each lamp belongs to a zone and each lamp has got its own switch. Presence detectors are installed in each controlled room.

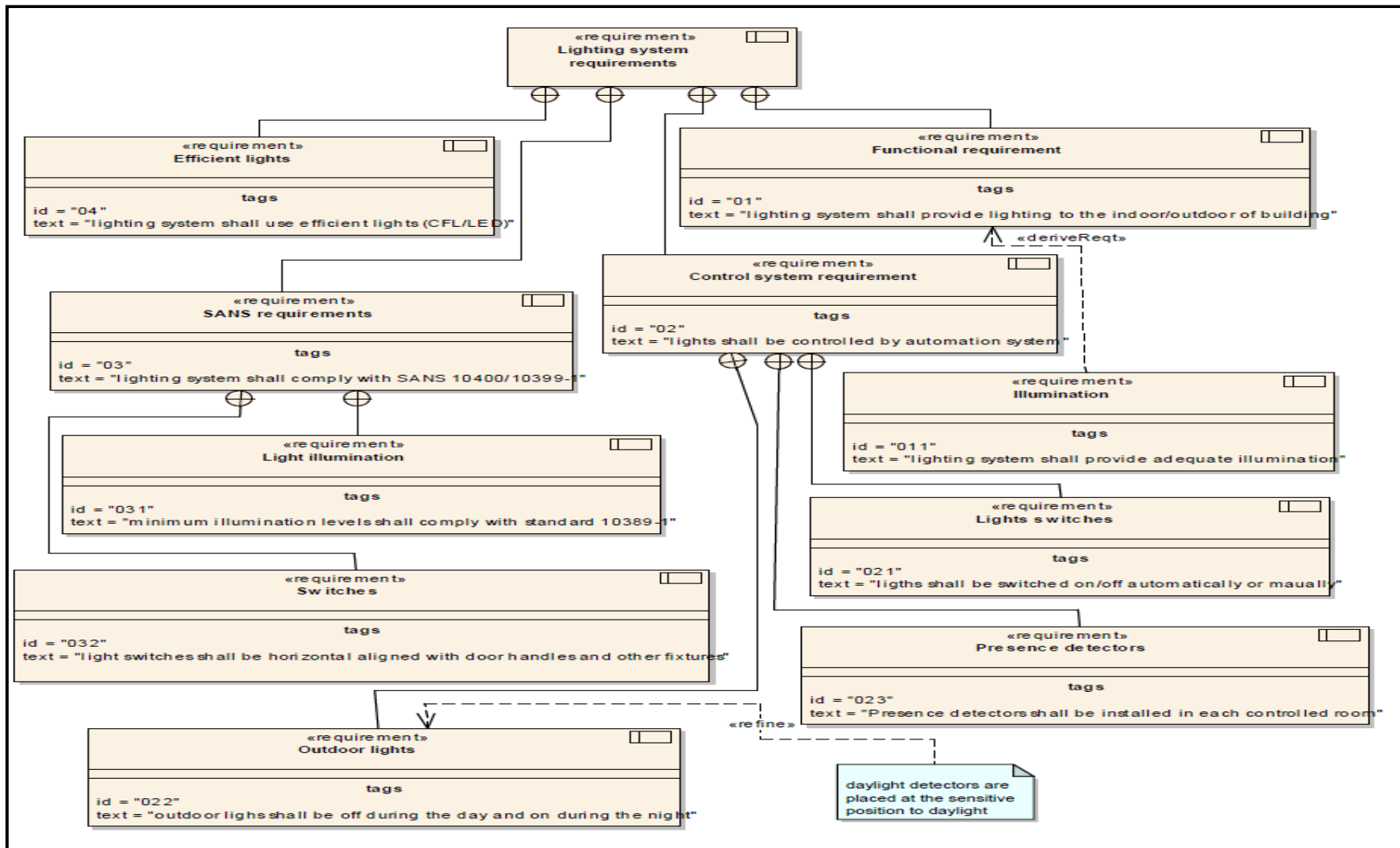
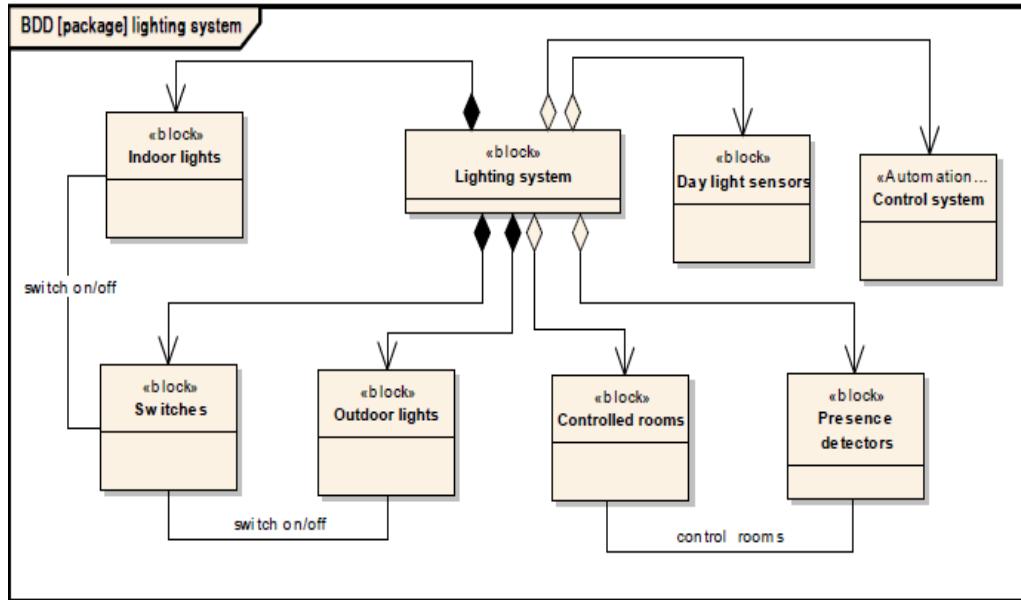


Figure 5.11: Requirement diagram of lighting system that describes main requirements to perform lighting system



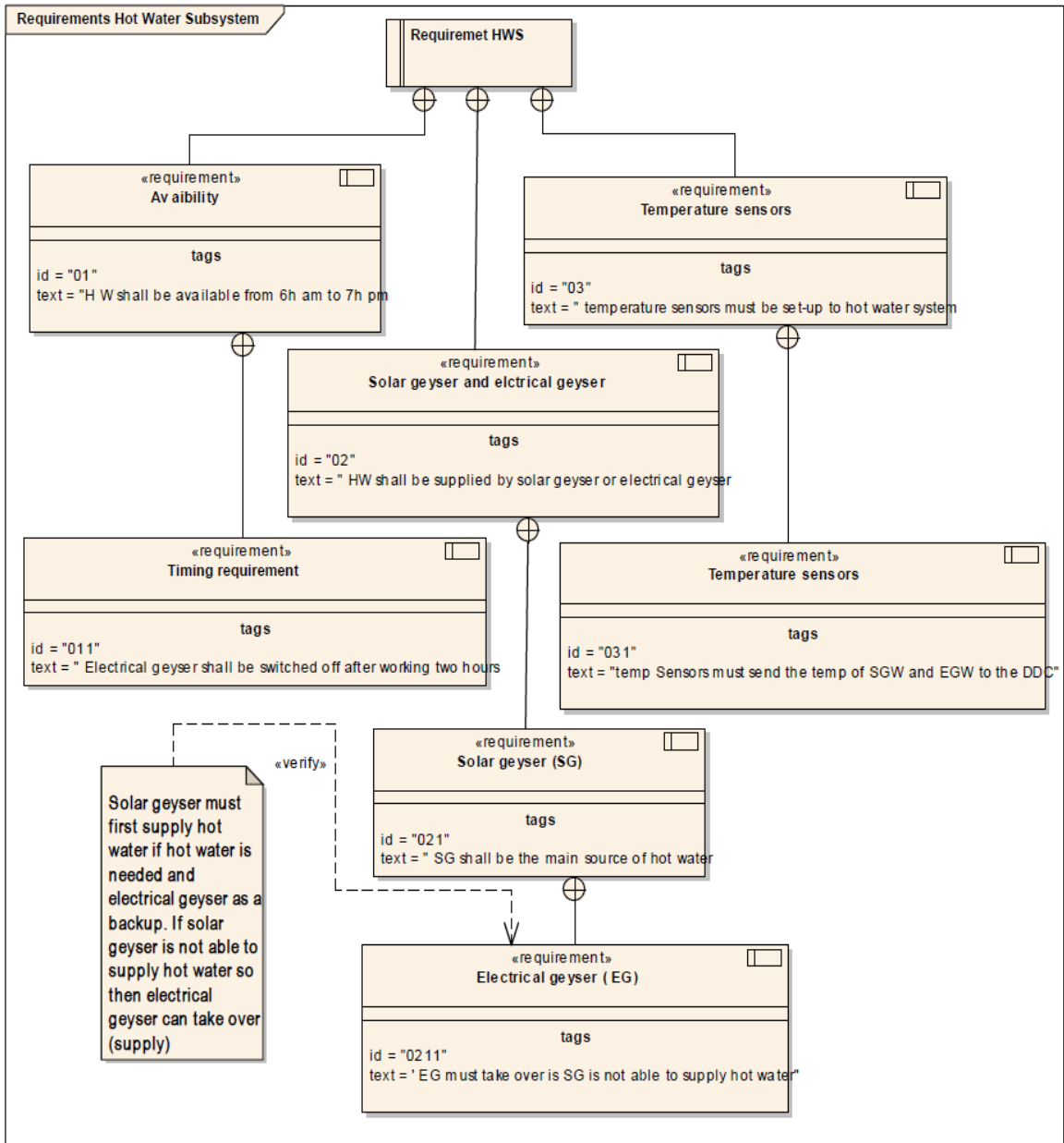
**Figure 5.12: Block Definition Diagram of lighting system that describes the main elements of lighting system**

### 5.1.1.3 Hot water system

Hot water system is an indispensable system to the residential building according to the South African norms of residential building. Hot water system is required to residential building for bathing, washing dishes, cleaning and washing clothes during cold season. That is why the hot water system is one of the main requirements.

Hot water system is one of the big consumers of electrical energy in the residential building; therefore some requirements are set up to meet energy efficiency. Figure 5.13 is the requirement block of hot water system that describes the main requirements to mitigate the consumption of electrical energy by hot water system.

The first block child of parent block HWS requires that hot water must be available from 06.00 to 19.00, because the probability for need of hot water during this period could be very high. The automation system must activate the hot water system during that period. The next block child requires that a solar geyser must be installed to the building, and the derivative block requires that the solar geyser will be the main source of hot water. Setting up a solar geyser contributes a lot to the energy efficiency policy. If a solar geyser is not able to supply hot water, the electrical geyser can take over. In that case automation system will be shifting the state on/off of electrical geyser. That means once the cylinder water starts getting cold and the temperature reaches set point value, automation system will be shutting on the electrical geyser for two hours.

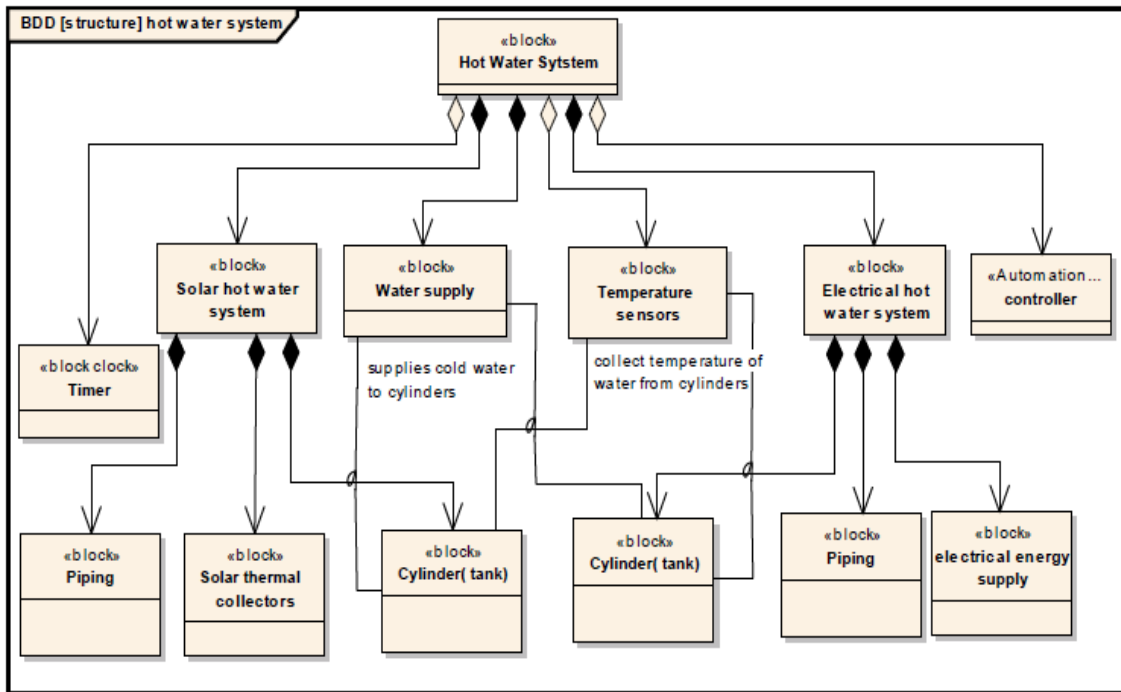


**Figure 5.13: Requirements diagram for hot water system that describe the main requirements to hot water system**

The following block child explains that temperature sensors are required for hot water system, to collect the temperature of water in the cylinders of solar and electrical geysers and send the information to automation system.

Figure 5.14 is the Block Definition Diagram (BDD) of hot water system describing main parts of hot water system and its relation. Hot water system comprises; solar geyser and electrical geyser, water supply system, temperature sensors, controller and timer. Solar hot water system is made up of a piping system, cylinder (tank), and solar thermal

collectors. Electrical geyser is made up of a furnace cylinder, piping system, and power supply.



**Figure 5.14: Block Definition Diagram describing main parts of hot water system**

Figure 5.15 is Internal Block Diagram (IBD) of water system describing items flow. The block environment regroups source of energy such electrical energy, cold water and solar energy. Block technology regroups collectors, sensors and cylinder for solar geyser, and furnace/cylinder and temperature sensors for electrical geysers. The block building regroups building hot water taps. Regarding solar geyser, weather condition is the main source of energy that supplies solar radiations to the solar thermal collectors, at the same time the water supply system provides cold water to the thermal collector; thermal collectors transform solar radiations to heat energy, next collectors warm up water supplied by water supply system, and supply hot water to the cylinder. Once water is needed the cylinder supplies hot water to the taps.

Regarding electrical geyser, water supply system supplies cold water to the cylinder and power supply supplies electrical energy to the furnace, next the furnace heats the water and supplies the building taps with hot water as and when needed.

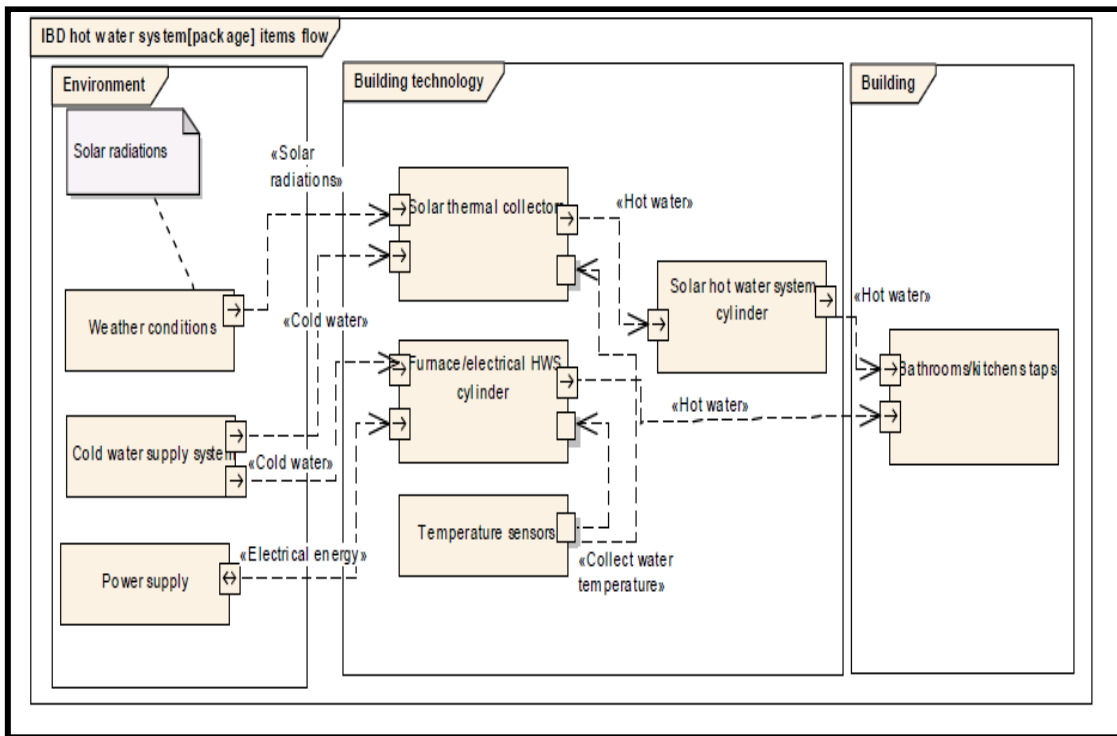
Temperature sensors collect the temperature of water in the cylinders of solar and electrical geysers, and send the information to the DDC. If a solar geyser is operating, DDC energizes actuators to close electrical geyser piping and open solar geyser piping.



If an electrical geyser is operating, DDC energizes actuators to close solar geyser piping through valves and open electrical geyser piping.

#### 5.1.1.4 Heating Ventilating and Air Conditioning system (HVAC)

To keep building's occupants healthy, the indoor climatic conditions of the building are required to be convenient and comfortable. That is why HVAC system is required for the residential building. To prevent the overconsumption of energy, some requirements are established to which HVAC system must comply.



**Figure 5.15: Internal Block Diagram of hot water system describing energy and matter flow**

Figure 5.16 is the requirements diagram enumerating main requirements to which HVAC system shall comply to provide desired Indoor Air Quality (IAQ), safety and energy efficiency objectives. The first block child, requires that HVAC system must comply with SANS and SABS requirements. According to SANS and SABS, piping and ducts of HVAC system shall be insulated to minimize heat evasion that could increase heating load, and HVAC system shall be chosen and sized according to the heating and cooling loads.

The following block child gives the standards temperature and relative humidity in the hot and cold season that the HVAC system shall be able to provide in the way to keep indoor climatic conditions comfortable and convenient.

The next block child requires that HVAC system shall be controlled by automation system to provide the temperature that occupants want at the same time to enable the energy management. The derivative block child requires that HVAC system shall use only heat Pump to perform energy efficiency objective.

Figure 5.17 is the Block Definition diagram that depicts the structure of HVAC system and its related system represented by blocks. HVAC is made up with heat pump that is connected to the automation system. Heat pump is made up with evaporator, condenser, refrigerant, compressor and expansion valve as main components, and air handling system which is made up with dumper, air filter valves, ducts, and diffusers. The related part or automation system is made up with transducer, DDC, actuators, valves, timer, temperature sensors, and thermostat.

Figure 5.18 is the internal block diagram that depicts through blocks different elements of HVAC system, its related system, and connectors that express the flow of information, energy commands and others items. The connector between heat pump and power supply is cabling that allow the flow of electrical energy supplied to heat pump.

The connectors between heat pump, air handling system, environment, and controlled rooms are ducts through which air and heat flow. If heat is needed in the controlled rooms, the heat pump absorbs heat from outdoor and supplies to the controlled rooms through air handling system ducts.

The connectors between temperature sensors and DDC are buses that enable temperature sensors to transfer information (temperature values) collected from the controlled rooms and send them to DDC.

The connector between DDC and thermostat, are buses that transfer the message from thermostat to DDC. The building's occupants set the desired temperature in the controlled rooms by mean of thermostats, and thermostats send analog signals to DDC.

The connectors between actuators and DDC are buses that allow DDC to energize actuators. That means DDC compares data furnished by temperature sensors and thermostats, if they do not match, DDC energize actuators to perform the system.

The connectors between actuators and valves enable actuators to act on valves, switches to control the flow of air, heat, and electrical energy at the same time to control and reverse the flow of refrigerant in the heat pump.

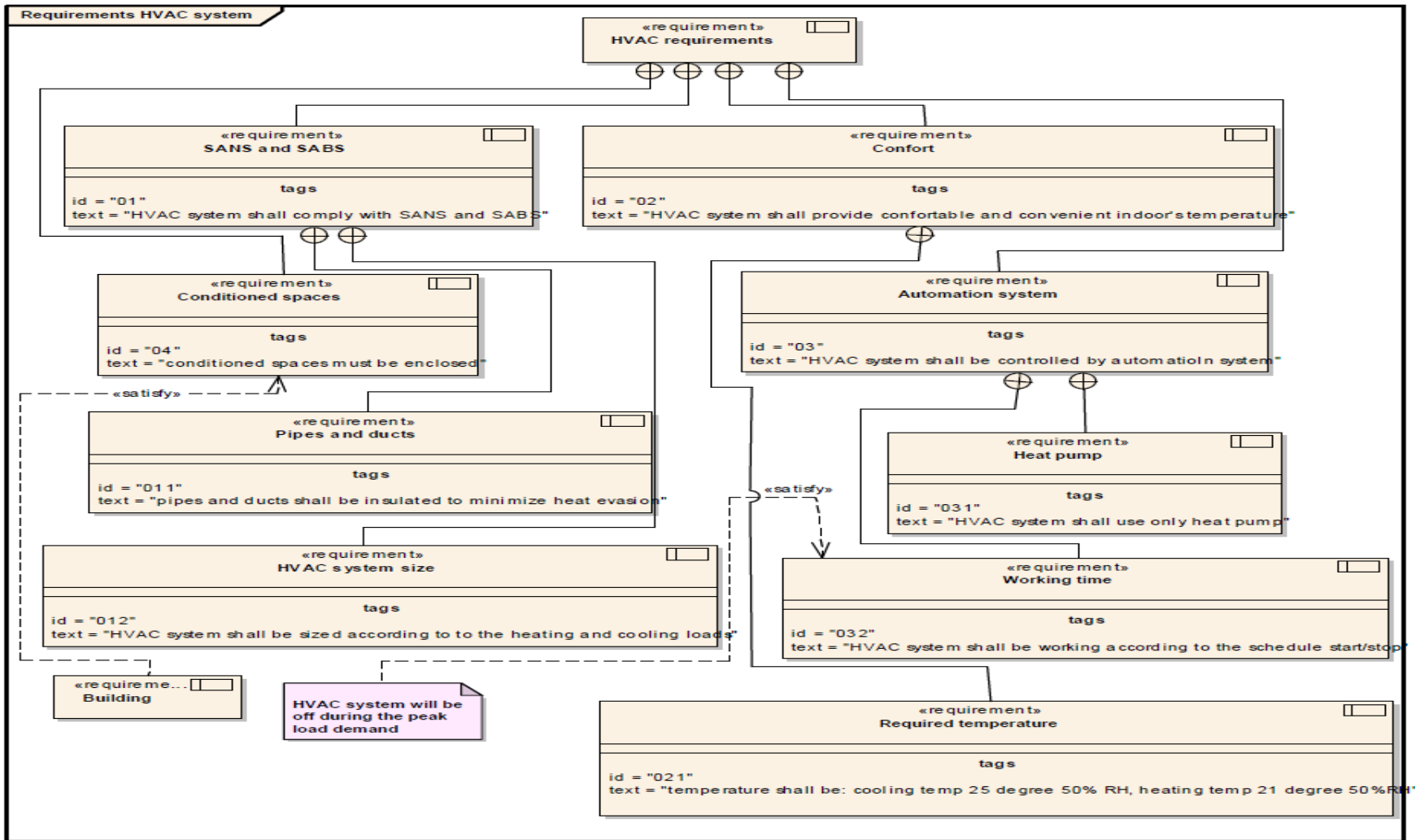


Figure 5.16: Requirements diagram of HVAC system enumerating main requirements to which HVAC shall comply

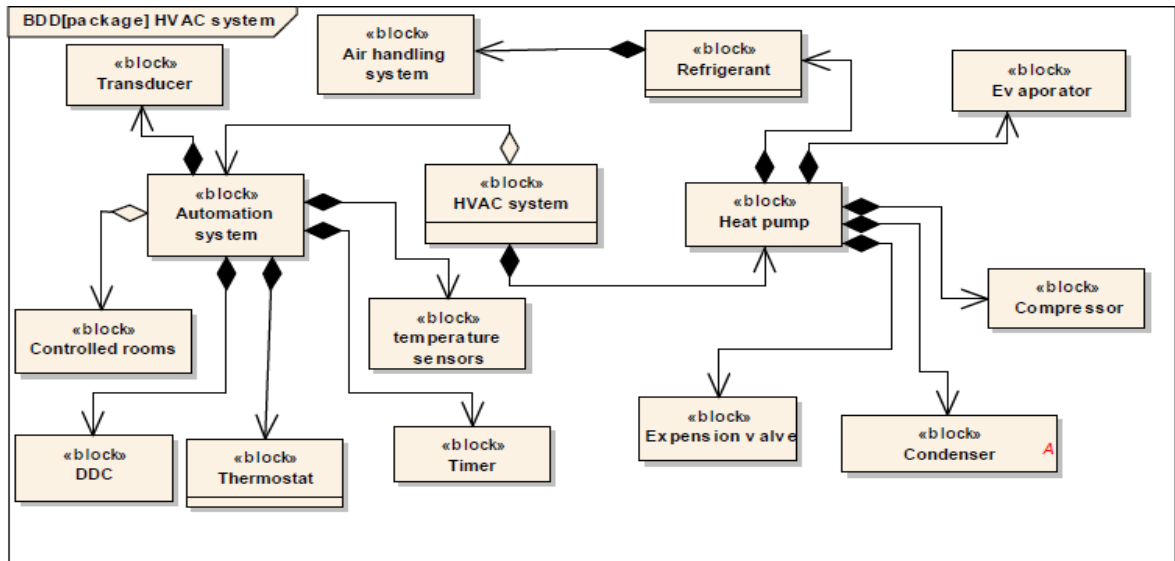


Figure 5.17: Block definition diagram of HVAC system that describes the main components of HVAC system

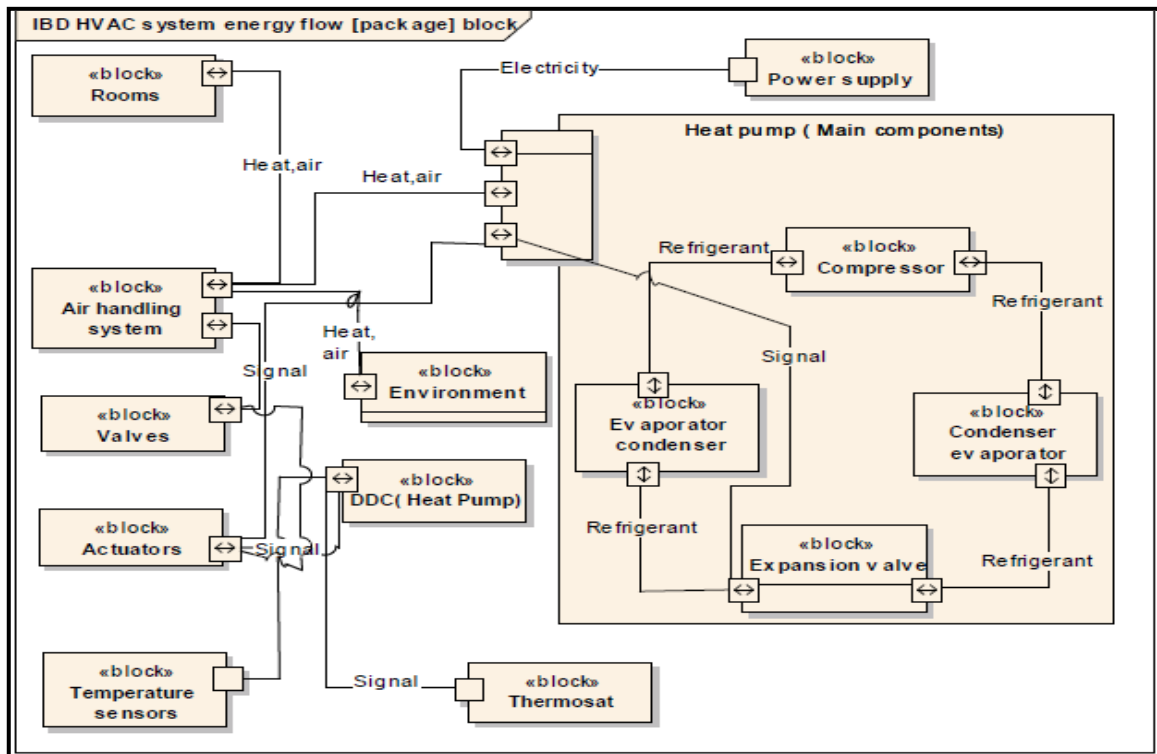


Figure 5.18: Internal Block Diagram of HVAC system that depicts the structure of HVAC system and the items flows

The connectors between compressor, condenser, evaporator and expansion valve, are piping in which the refrigerant flow. This system is reversible, that is to say, when the refrigerant flows in one direction, the system supplies heat in the controlled zones (heating), and when the direction of the refrigerant reverses, automatically the evaporator and the condenser shift, and the system shifts as well to the cooling phase by removing heat from the controlled zones.

## 5.2 Behaviour of Building's system

Figure 5.19 is the diagram used that describes the building's systems and their services provided to the building occupant by means of electrical energy. Blocks child enumerate the building's devices or building's energy end uses. Each energy end use and its task are linked with each other, and services are linked to the automation system as described in the diagram. The building occupant is the centre of each activity and task.

Figure 5.20 is the activity diagram of the building energy showing the flow process of energy and items through blocks and connectors. In the environment block, energy grid block represent the power supply that is the main source of building energy to supply the building's system with electrical energy. Weather conditions block represents the sunny season in summer, when the intensity of solar radiations reaches the peak level and solar radiation intrude into the building through the building envelope (solar heat gain), at the same time solar radiation is supplied to the solar geyser through the collectors to heat water. The Block atmosphere represents the outdoor atmosphere in the winter season when the outdoor atmosphere absorbs heat from indoor atmosphere through the building envelope (heat losses). The Building technology block regroupes energy end uses or building's system that transform the input electrical energy to output services desired by the building 'occupants'.

Figure 5.21 is the activity diagram of the hot water system that is working according to the automation system program; all systems are controlled by timers and sensors. According to the building's occupants hot water must be available from 5 am to 8 pm. Later during the night around 7 pm, timers send signals to DDC to switch off electrical geysers if they were on. Earlier in the morning around 4 am, timers send signal the DDC, DDC switches on electrical geysers for each apartment during two hours from 4 am to 6 am.

From 7 am to 7 pm, sensors keep on measuring the water's temperature of Solar Geysers (SGW) and send data to DDC. DDC compares the set point temperature (65<sup>0</sup> Celsius) with the sampled temperature. If the sampled temperature is higher than set

point temperature, DDC switches off electrical geysers and solar geyser (SGW) starts supplying hot water till the water's temperature of SGW drops to less than the set point temperature. When the temperature of solar geyser's water becomes less than set point temperature, DDC keep shifting on and off electrical geysers for each apartment till 7 pm. If the temperature of SGW is less than the set point temperature, DDC start shifting on and off the electrical geysers till 7 pm. When the temperature of water becomes less than set point, DDC switches on electrical geysers. At the same times sensors keep measuring the temperature of solar geysers. If the temperature reaches set point temperature, DDC switches on electrical geysers and the cycle continues.

Figure 5.22 is the activity diagram of lighting system that is made up with two branches, that is to say indoor lights and outdoor lights connected to the automation system as explained previously and described by structural diagrams. For indoor lights, presence detectors keep controlling the rooms and send signals to DDC, if any controlled room is occupied, DDC switches on lights of the occupied room, and if any controlled room is unoccupied, DDC switches off lights of the unoccupied room. For outdoor lights, daylight sensors send information to the DDC, if daylight is available, DDC switches off outdoor lights, and if the daylight is not available, DDC switches on outdoor lights through actuators.

Figure 5.23 is the activity diagram of automation system program based on the main requirements of energy end uses in order to meet energy efficiency with these large consumers of energy. The automation system controls through sensors and detectors if; lighting system is using CFL or LED at least 80% of the all lights, Hot water system is using solar geyser as the main source of hot water and if the system is using HP for cooling and heating according to the program. If these requirements are satisfied that means the system is steady and the system performs task continuously, if these requirements are not respected, the system will trigger the alarm and displays the matter to the monitor of the computer workstation by defining it.

To wrap up, point 5.2 was the overview of behavioural diagrams that defines the behaviours of the building's systems, energy flow and automation system. These activity diagrams can be used through the software to generate codes of the system. The following point is the heating and cooling loads calculation and simulations to predict heating and cooling loads.

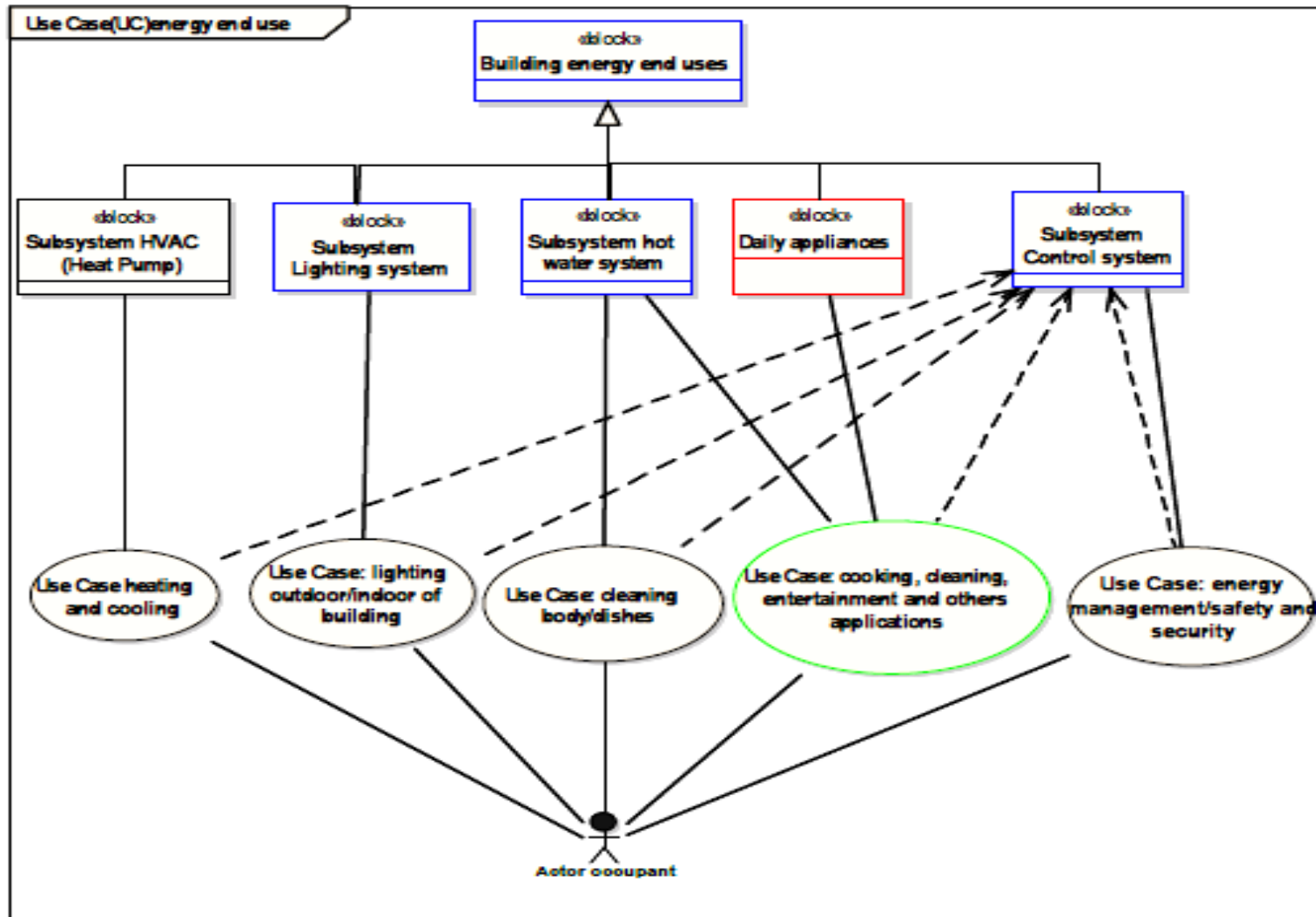


Figure 5.19: Use Case diagram that describe building's energy end use with their services required by the building occupant

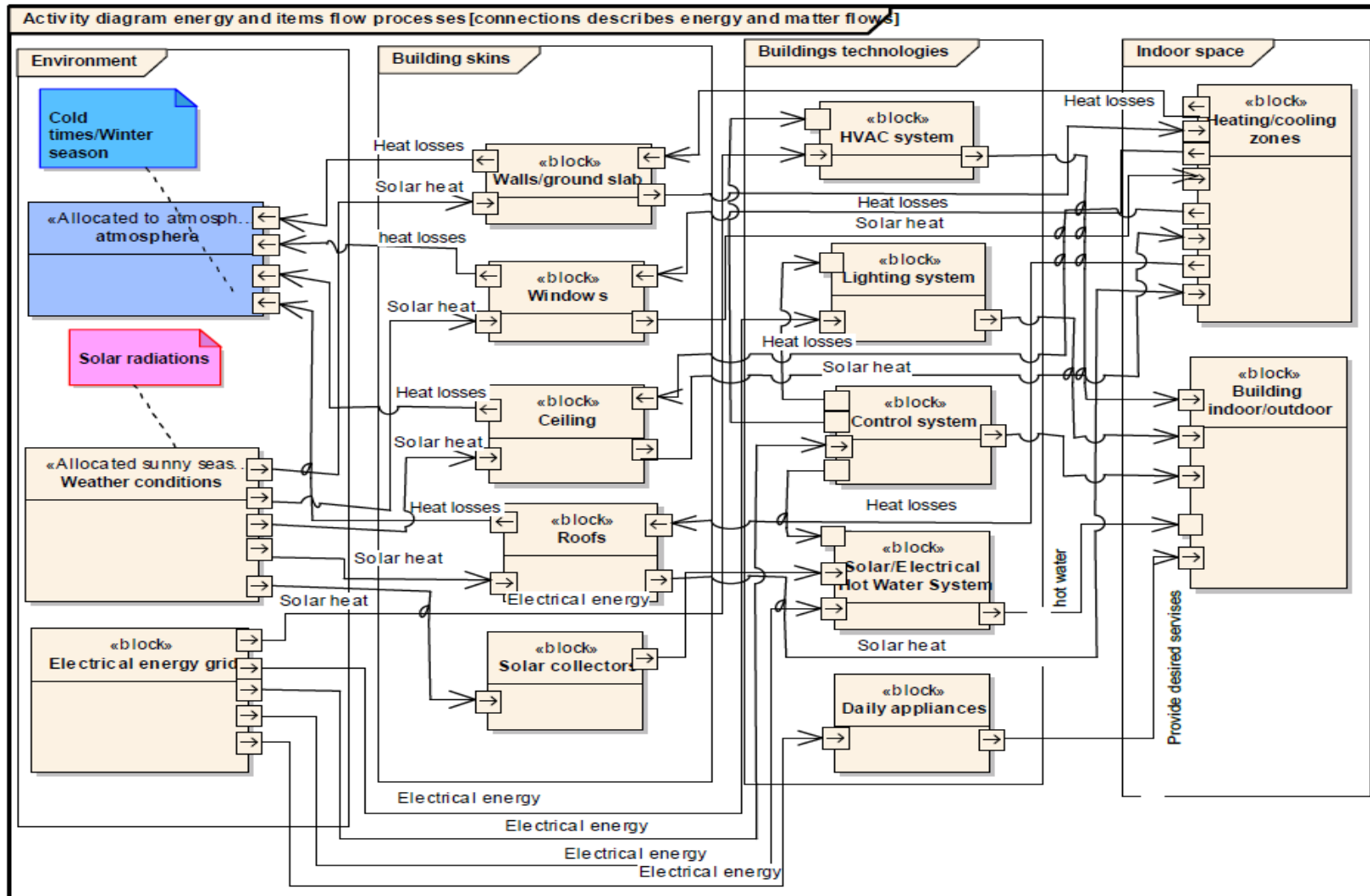


Figure 5.20: Activity diagram of energy and items flow into the building with connectors describing items and matter flow



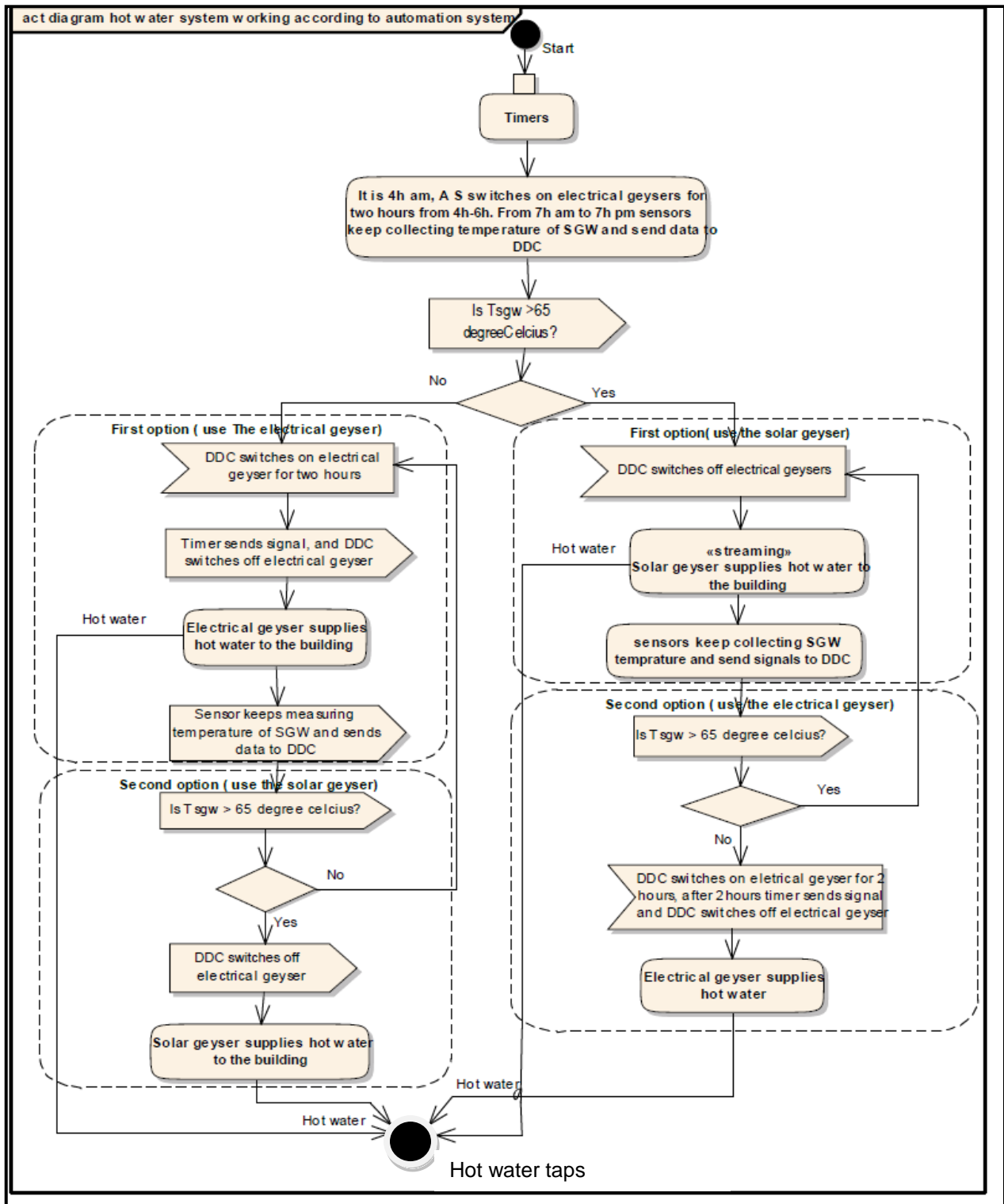


Figure 5.21: Activity diagram of hot water system working according to automation system

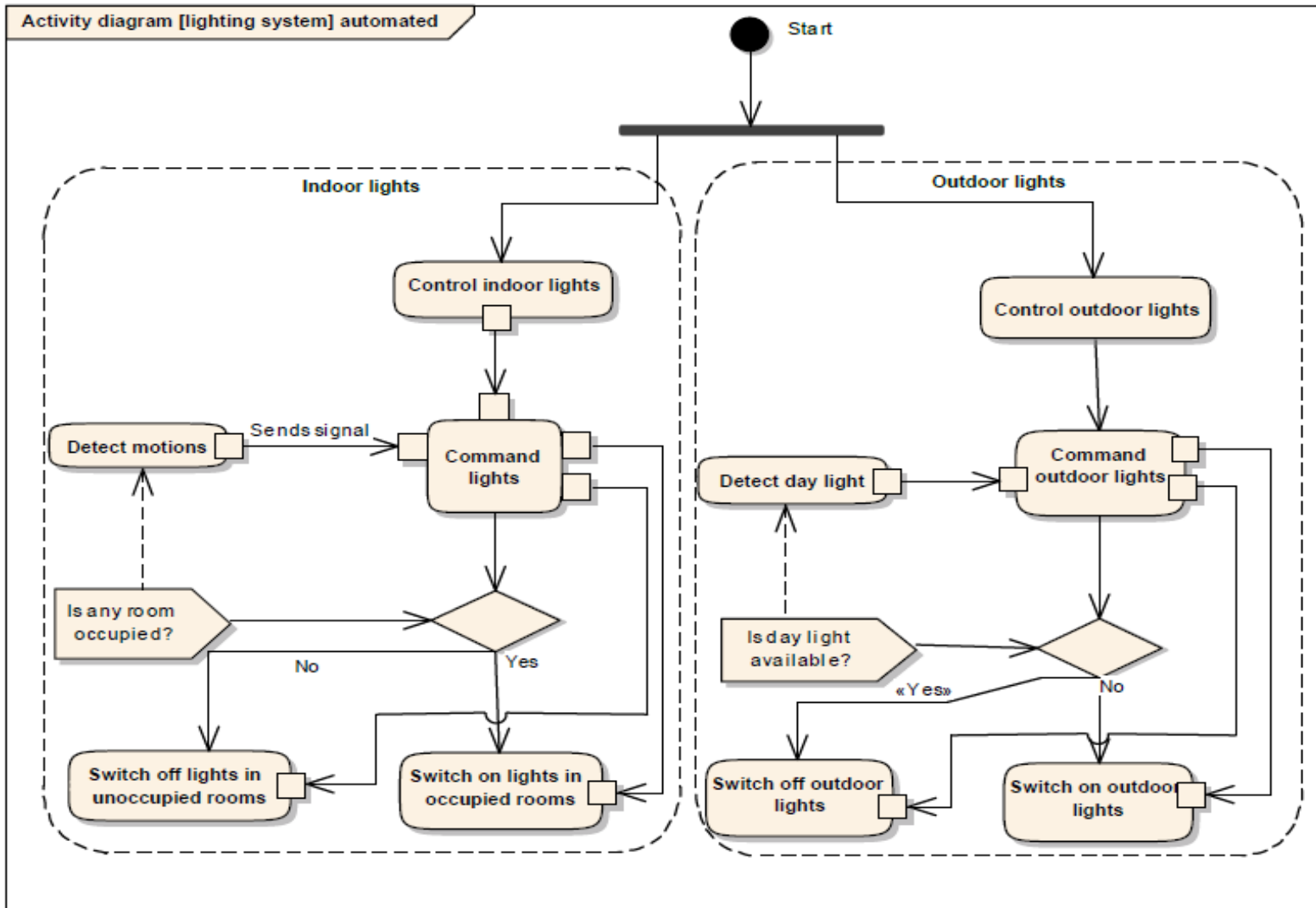


Figure 5.22 Activity diagram of automated lighting system

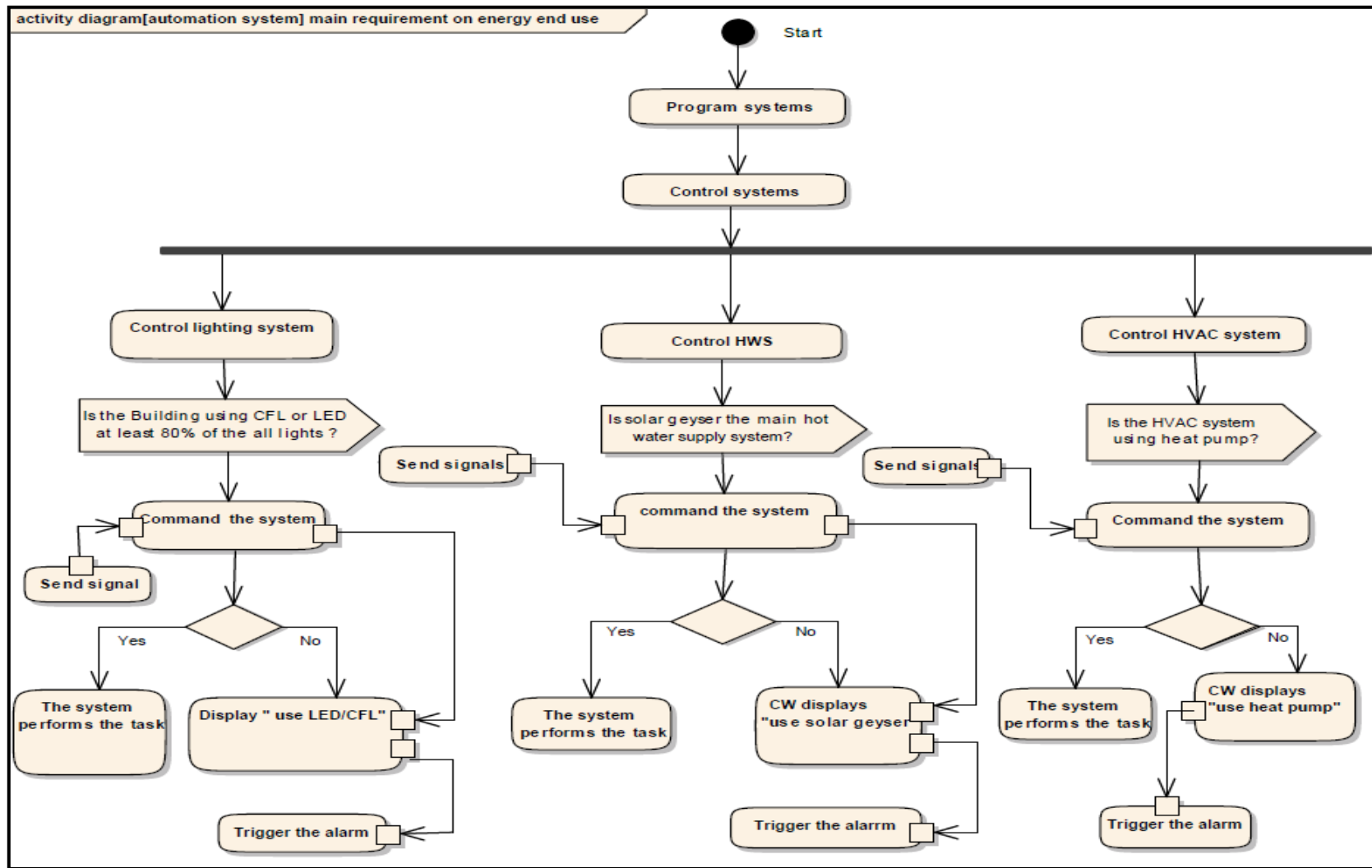
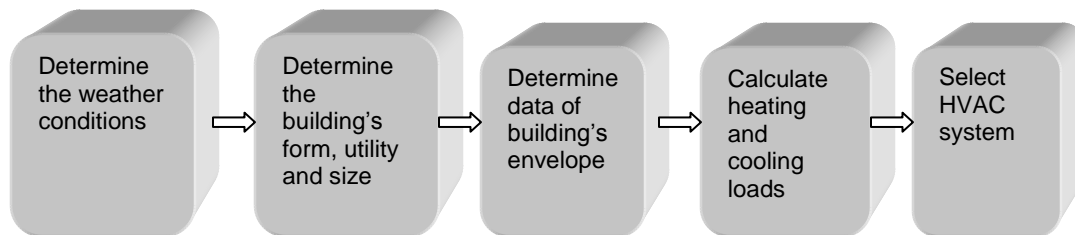


Figure 5.23: Activity diagram of automation system describing the automation's program based on the main energy efficiency requirements

### 5.3 Heating and cooling loads calculation and simulations

The selection of HVAC system goes through many steps in the designing process that is based on the right-sizing of HVAC equipments. Right-sizing the HVAC system begins with an accurate understanding of the heating and cooling loads on a space, and it is selecting HVAC equipments and designing the air distribution system to meet the accurate prediction of heating and cooling loads in the building (Burdick, 2011).

Heating and cooling loads are the amount of heat needed to be added or removed respectively from the space to provide a comfortable temperature within a space. Heating and cooling loads are the big factors are ones of the previous decisive steps during the designing process. (Burdick, 2011), explains that heating and cooling loads calculation result will have a direct impact on the first construction cost along with the operating energy efficiency. Figure 5.24 describes different steps to collect the building information for a successful selection of HVAC system.



**Figure 5.24: Different steps to right-size HVAC System**

#### 5.3.1 Cooling loads

The peak cooling load is the peak amount of heat in the building, which must be removed by the HVAC system to keep the comfortable indoor temperature, it comprises sensible and latent heat gain. The cooling load is made up with external, internal and ventilation loads, as internal load definition describes on Figure 5.27. The internal load is the heat from electrical devices (lights, oven, toaster etc...) and people. The ventilation load is the load from HVAC system.

### 5.3.1.1 Empirical methods for estimating external cooling load

The external load is the heat intruded through the building envelope in the building from the outdoor environment. That heat is from solar radiation that gets into the building through the external walls, roof, door, floor and fenestration (windows). Different empirical methods were used for estimating heating and cooling loads.

Empirical methods developed some equations for estimating the solar radiations that go through the fenestration or transparent surface such as the glass for windows. According to the empirical estimations, the amount of solar radiations passing through the transparent surface is expressed as:

$$Q_{sg} = A(\tau \cdot I_t + N \cdot \delta \cdot I_t) \quad (5.1)$$

where  $Q_{sg}$  is the heat passing through the material,  $A$  is the area of the surface exposed to solar radiations,  $I_t$  is the total radiation incidence on the surface,  $N$  is the fraction of absorbed radiation transferred to the indoor by conduction and convection,  $\tau$  is the transmittivity of glass for direct diffused and reflected radiations,  $\delta$  is the absorptivity of glass for direct diffuse and reflected radiations. Under steady state condition, the fraction of absorbed radiation transferred to indoor is expressed as:

$$N = \frac{U}{h_o} \quad (5.2)$$

Where  $U$  is the overall heat transfer coefficient and  $h_o$  is the external heat transfer coefficient. By combining equations 5.4 and 5.5, the heat passing through the glass is expressed as:

$$Q_{sg} = A \left[ I_t \left( \tau + \frac{\delta U}{h_o} \right) \right] \quad (5.3)$$

For a single sheet clear window glass, the term in square brackets is called as Solar Heat Gain Factor, (Kharagpur, 2008). To other buildings, the solar radiation incident on a glazed window is considerably reduced by using external shading. The external shading reduces the area of the window exposed to solar radiation, and thereby reducing the heat transmission into the building. The most widely used for providing external shading

is the overhangs. Thus for the building with external shading, the solar radiation passing through the fenestration is given by:

$$Q_{sg} = A_{unshaded} \cdot (SHGF_{max}) \cdot SC = (x \cdot y) \cdot (SHGF_{max}) \cdot SC \quad (5.4)$$

Where  $A_{unshaded}$  is the unshaded surface of the window, SC is the shading coefficient, x and y are the width and the height respectively of the no shaded area of the window that vary according to the solar geometry at any location at a particular instant. Thus x and y are given by:

$$x = W - d(\tan \alpha) \quad (5.5)$$

$$y = H - d \left( \frac{\tan \beta}{\cos \alpha} \right) \quad (5.6)$$

Where W is width of the inset window, H is the height of the inset window, d is the depth of the inset window,  $\beta$  is the altitude angle and  $\alpha$  is the wall solar azimuth angle. Previous equations were developed to calculate the solar radiation transmitted into the building through the window glazing, the following equations are developed to calculate solar radiation transmitted into the building through fabric heat gain. Fabric heat gain includes sensible heat transfer through the wall, floor, roof etc..., but that does not include radiation heat transfer through fenestration.

The fabric heat transfer is assumed to be steady if the indoor and outdoor conditions do not vary with time. The fabric heat gain/loss is assumed to be one-dimensional if the thickness of the building wall is small compared to the other two dimensions (Burdick, 2011). External wall is the big factor of fabric heat gain.

In general, there are two types of external walls, homogenous and non-homogenous walls. Heat transfer rate per unit area  $Q_{in}$  of homogenous wall under steady state is expressed as:

$$Q_{in} = \{q_{c/o} + q_{r/o}\} = \{q_{c/i} + q_{r,i}\} \quad W/m^2 \quad (5.7)$$

Where  $q_{c/o}$ , and  $q_{r/o}$  are the convective and radiation transfer of heat to outer surface of the wall from outside, and  $q_{c/i}$  and  $q_{r,i}$  are the convective and radiation transfers of heat to

the inner surface of the wall into inside. The liberalized radiation heat transfer rate per unit area is expressed as:

$$Q_{in} = h_o(T_o - T_{w,o}) = h_i(T_{w,i} - T_i) \text{ W/m}^2 \quad (5.8)$$

Where  $T_o$  and  $T_i$  are the outdoor and indoor temperature,  $T_{w,o}$  and  $T_{w,i}$  are the outer and inner surface temperature of the wall respectively, and  $h_o$  and  $h_i$  are the outer and inner heat transfer coefficients or surface conductance. Using the resistance networking methods, the surface conductance  $h_o$  and  $h_i$  are given as:

$$h_i = h_{c,i} + h_{r,i} \left( \frac{T_{w,i} - T_{s,i}}{T_{w,i} - T_i} \right) \quad (5.9)$$

$$h_o = h_{c,o} + h_{r,o} \left( \frac{T_{s,o} - T_{w,o}}{T_o - T_{w,o}} \right) \quad (5.10)$$

Where  $h_{c,i}$  and  $h_{r,i}$  are convective and radioactive inner heat transfer coefficients respectively, and  $h_{c,o}$  and  $h_{r,o}$  are convective and radioactive outer heat transfer coefficients respectively.

If the values of the surface temperature of the wall ( $T_{w,i}$  and  $T_{w,o}$ ) are neglected or zero, the steady state heat transfer rate per unit area of the wall is calculated by taking into account only overall heat transfer, and the indoor and outdoor temperature. In this case the heat transfer is given as:

$$Q_{in} = U(T_o - T_i) = \frac{(T_o - T_i)}{R_{tot}} \text{ W /m}^2 \quad (5.11)$$

The overall heat transfer coefficient is given by:

$$\left( \frac{1}{U} \right) = \frac{1}{h_i} + \frac{\Delta X}{K_w} + \frac{1}{h_o} = R_{tot} \text{ W/m}^2\text{K} \quad (5.12)$$

Where  $\Delta X$  and  $K_w$  are thickness and thermal conductivity of the wall respectively.

In South Africa, the walls of some buildings are non-homogenous, multi-layered and non-isotropic. Non-homogenous wall, heat transfer implicates simultaneous heat transfer

by convection, radiation and conduction. As result, the heat transfer network Q is comprises paths, parallel and series, and it is given as:

$$Q = C(T_{w,o} - T_{w,i}) \frac{W}{m^2} \quad (5.13)$$

Where C is the thermal conductance, which values have been tabularized and normalized by ASHRAE.

In South Africa, some buildings consists of air spaces between walls, it is used to provide effective insulation against heat transfer. In such a case, the heat transfer rate through the spaces is liable to its width, surface emissivity of the wall surface and the temperature difference between the two surfaces. The heat transfer rate per unit area is expressed as:

$$Q = C(T_1 - T_2) \quad (5.14)$$

In order to reduce considerably the U-value, other buildings are built-up with composite walls multilayered and non-homogenous material combining insulating material and air spaces. In this case the heat transfer rate is mathematically expressed as:

$$Q_{in} = U(T_o - T_i) = (T_o - T_i/R_{tot}) \quad (5.15)$$

Where total heat resistance is given as:

$$R_{tot} = \frac{1}{U} = \frac{1}{h_1} + \sum_{i=1}^N \left( \frac{\Delta X_i}{K_{w,i}} \right) + \sum_{j=1}^M \left( \frac{1}{C_j} \right) + \left( \frac{1}{h_o} \right) \quad (5.16)$$

To wrap-up, these previous calculations are used to calculate the heat transfer through the wall. In the same case of fabric heat transfer, regarding the floor, roof and the door, the heat transfer is obtained by using the equations applied previously for homogenous walls. Those methods used previously to calculate the heat transfer through the building envelope are very complex and with the possibility of inaccurate values. To overcome these problems, ASHARA E suggests other versatile and laconic methods for predicting heating and cooling load with accuracy.



### 5.3.1.2 ASHAREA methods for estimation heating and cooling load

The methods suggested by ASHARAE for estimating cooling and heating load, are mostly used for residential and commercial buildings. Thus for estimating cooling and heating loads of large commercial and institutional building, more accurate methods have been developed, but those methods are very expensive and consume time to process.

For cooling load calculation, ASHARAE methods are using Solar Heat Gain Coefficient (SHGC), Cooling Load Temperature Difference (CLTD) and Cooling Load Factor (CLF) for standard building envelope. CLTD, SHGC and CLF are tabularized and found in ASHAREA handbooks. ASHAREA methods classified cooling loads ( $Q_{COL}$ ) in three categories such as: external cooling load ( $Q_{EXT}$ ), internal cooling load ( $Q_{INT}$ ), load from infiltration and ventilation ( $Q_{INF}$ ). Total cooling loads is given as:

$$Q_{COL} = Q_{EXT} + Q_{INT} + Q_{INF} \quad (5.17)$$

External cooling load comprises solar heat gain through fenestration area ( $Q_{FES}$ ), conductive heat gain through fenestration area ( $Q_{FE}$ ), conductive heat gain through external walls area ( $Q_W$ ), conductive heat gain through roof ( $Q_R$ ), and conduction heat transfer through floor area ( $Q_{FL}$ ) as described by figure 5.26. Thus external cooling load is given by:

$$Q_{EXT} = Q_{FES} + Q_{FE} + Q_W + Q_R + Q_{FL} \quad (5.18)$$

Whereas solar heat gain through fenestration area ( $Q_{FES}$ ) is expressed as:

$$Q_{FES} = (A_{unshaded} \cdot \max SHGF + A_{shaded} \cdot \max SHGF) \cdot SC \quad (5.19)$$

Where  $A_{unshaded}$  is the unshaded area of window glasses,  $A_{shaded}$  is the shaded area of the window glasses, SHGF is the solar heat gain factor, and SC is the solar coefficient. Conductive heat gain through fenestration area ( $Q_{FE}$ ), conductive heat gain through walls ( $Q_W$ ) and conductive heat gain through roof ( $Q_R$ ) are given as:

$$Q = A \cdot U \cdot CLTD \quad (5.20)$$

Where Q represents conductive heat gain through the matter such as: window, roof, wall as well, A represents the area of the matter, U represents the overall thermal transmittance of the matter, and CLTD is the cooling load temperature different. Conductive heat through floor area is expressed as:

$$Q_{FL} = A \cdot U(T_b - T_i) \quad (5.21)$$

Where A is the area of the floor, U is the overall heat transfer of floor, T<sub>b</sub> is the adjacent temperature and T<sub>i</sub> is the indoor temperature. This is the overall external cooling load, the next point expresses the internal cooling load.

Internal cooling load is the heat released by lights, appliances and the occupants divided in sensible heat gain and latent heat gain. Q<sub>INT</sub> is obtained by summing heat released by lights, people and the appliances, as shown by block definition diagram Figure 5.28, and it is mathematically expressed as:

$$Q_{INT} = Q_{LIT} + Q_{PEOP} + Q_{APPL} \quad (5.22)$$

Where Q<sub>LIT</sub> is the heat released by lights, Q<sub>PEOP</sub> are sensible and latent heats released by people and, Q<sub>APPL</sub> is sensible and latent heats released by appliances. Lights release sensible heat only. Sensible heat gain from lights is given as:

$$Q_{LIT} = Input \cdot F_{USE} \cdot F_{all} \quad (5.23)$$

Where Input is the total light wattage obtained from the ratings of all fixtures installed, F<sub>use</sub> is use factor defined as the ratio wattage in use possibly at design conditions installation conditions. Occupants of the building as human beings release heat Q<sub>PEOP</sub> in the building which is divided in sensible heat gain (Q<sub>SP</sub>) and latent heat gain (Q<sub>LP</sub>) and it is expressed as:

$$Q_{PEOP} = Q_{SP} + Q_{LP} \quad (5.24)$$

Whereas sensible and latent heat gain from people are expressed as:

$$Q_{SP} = n \cdot SHG \cdot CLF \quad (5.25)$$

$$Q_{LP} = n \cdot LHG \quad (5.26)$$

Where  $n$  is number of people in the conditioned room, SHG is sensible heat gain from people, LHG is latent heat gain from building's occupants and CLF is cooling load factor for people. Heat gain released by appliances is mathematically expressed as:

$$Q_{APPL} = (Installation\ wattage) \cdot (Usage\ factor) \cdot CFL \quad (5.27)$$

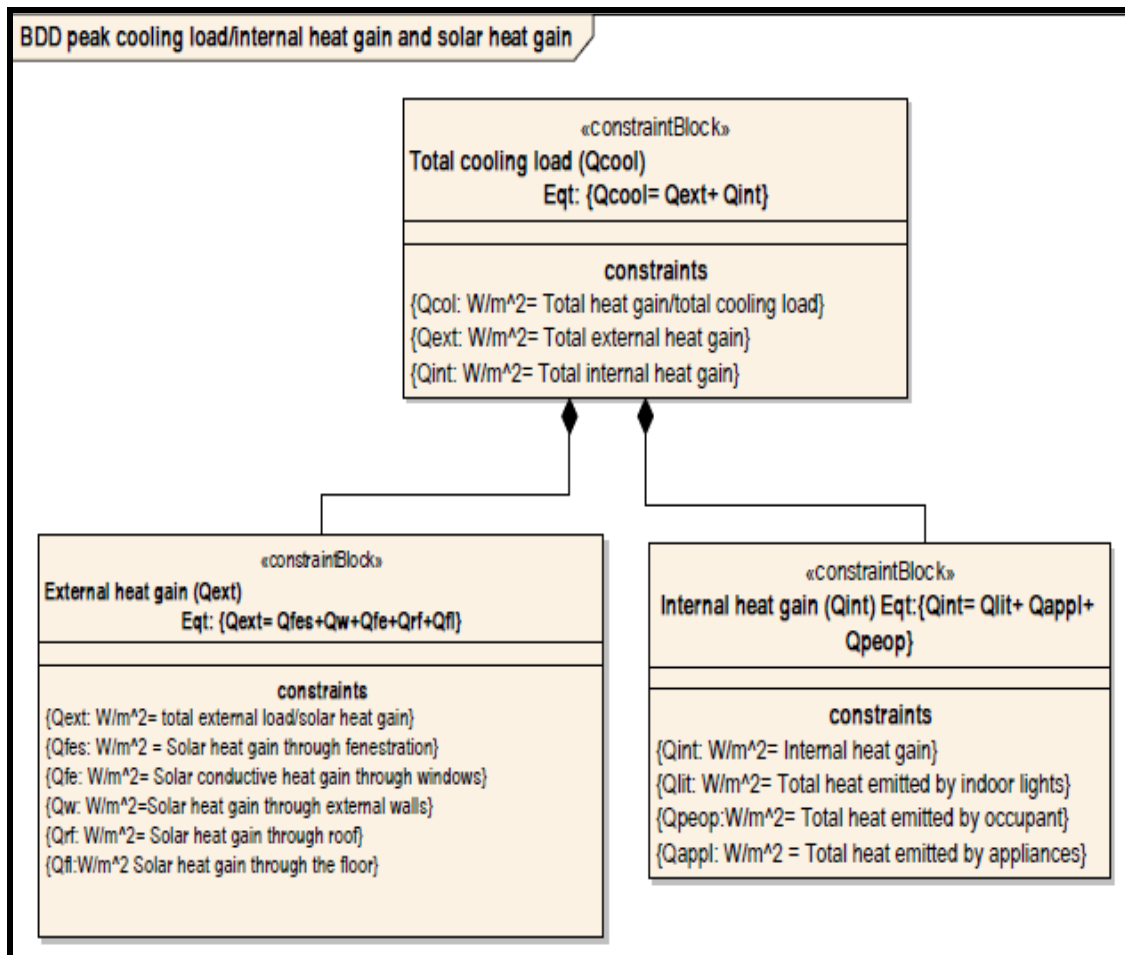


Figure 5.25: BDD diagram that describe total cooling load

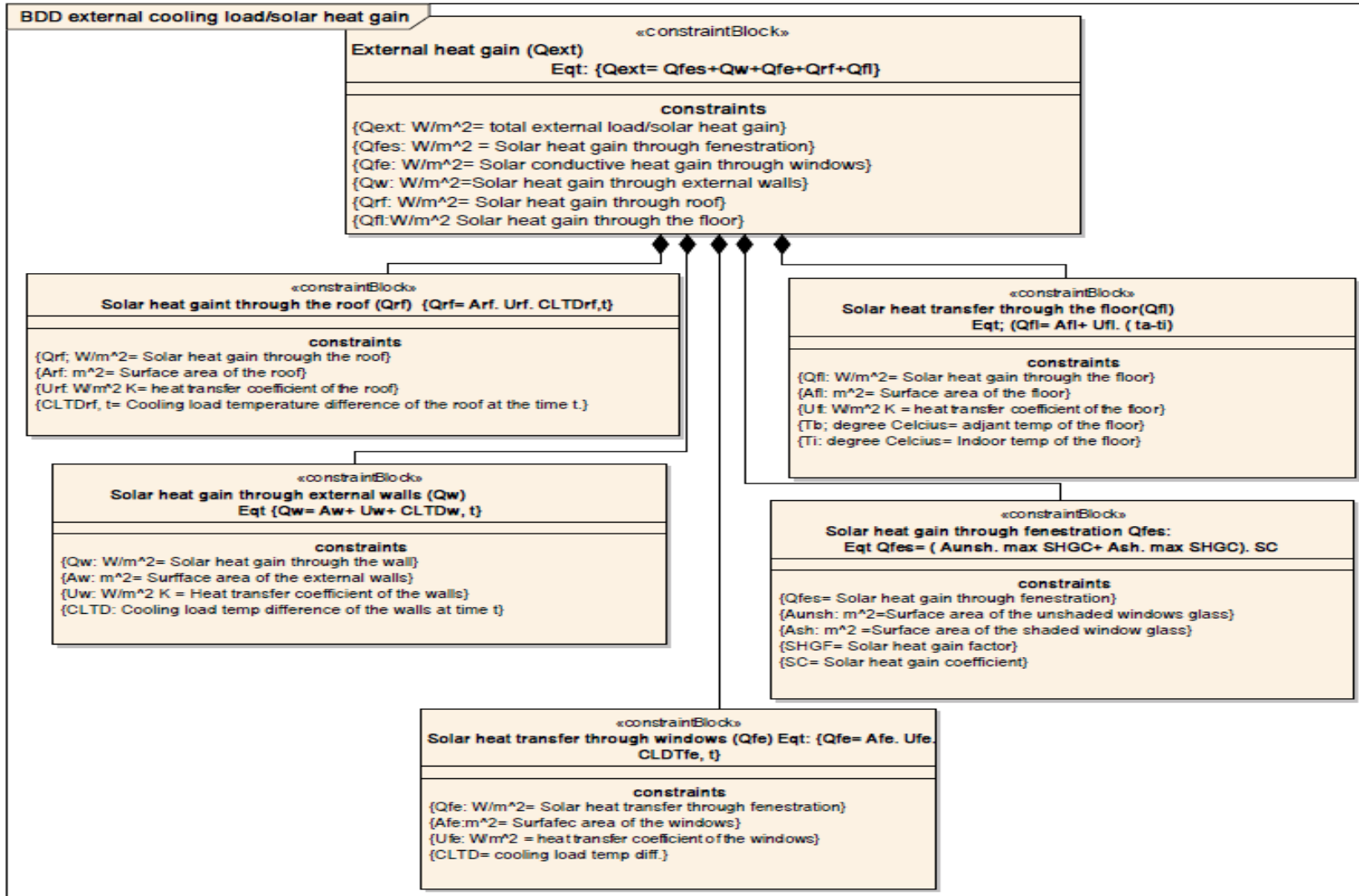


Figure 5.26: BDD diagram total external cooling load or solar heat gain

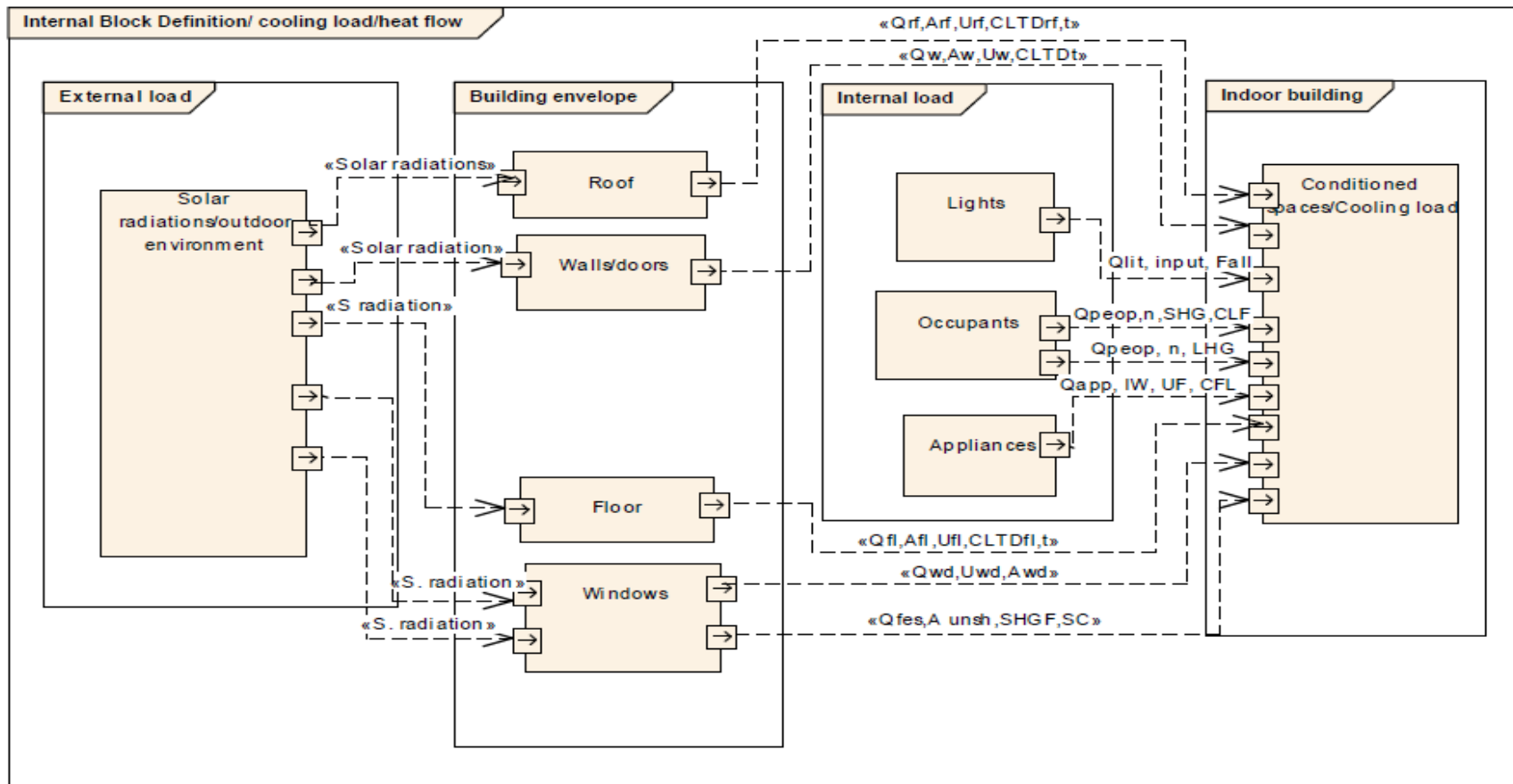


Figure 5.27: IBD expresses heat flow to the conditioned spaces that form cooling load

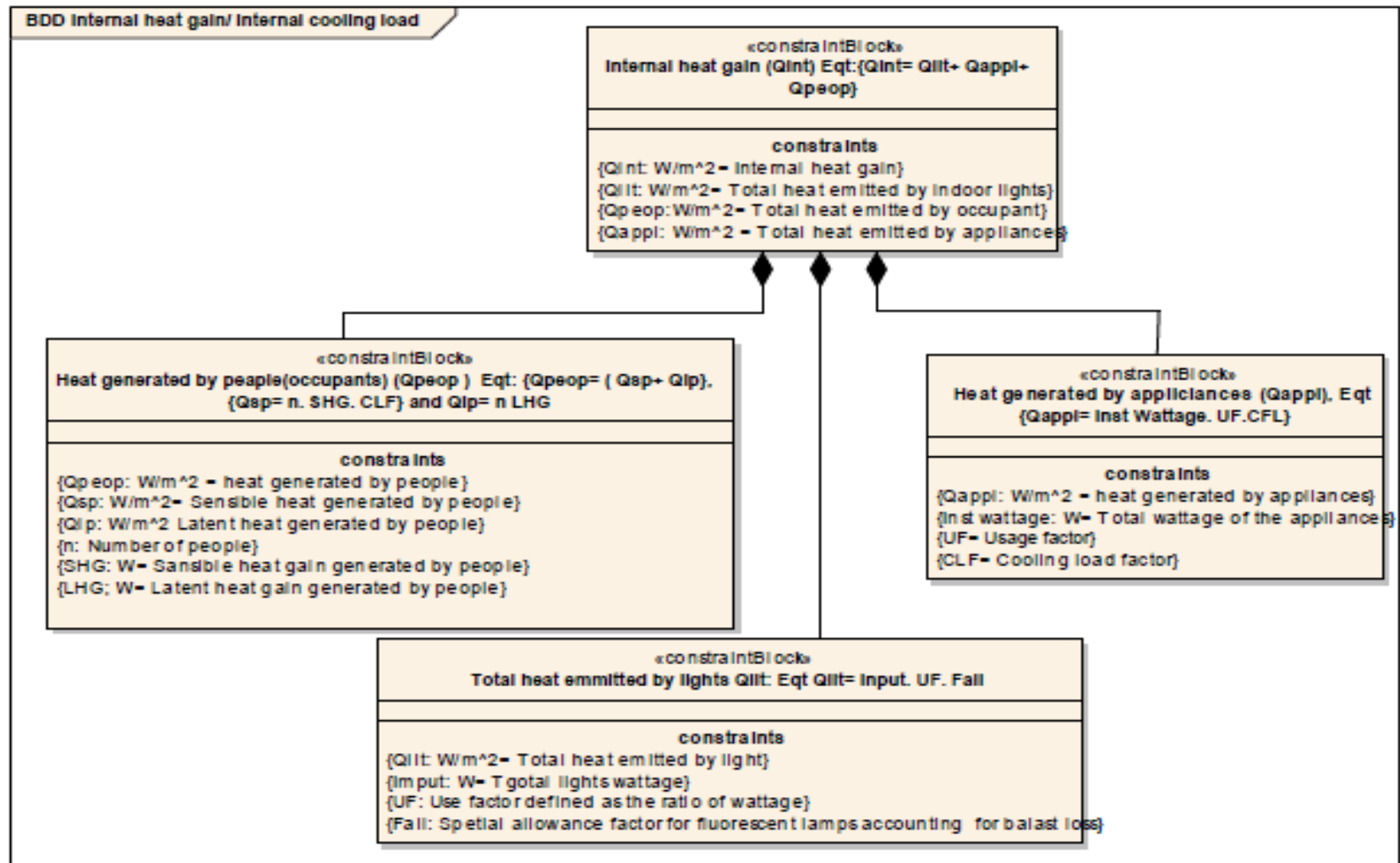


Figure 5.28: BDD diagram of internal cooling load

Figure 5.25 is a block definition diagram that defines constraints block of total cooling load which is made up with external and internal loads. In this case infiltration load is assumed insignificant. Figure 5.26 is a block definition diagram defining constraints blocks of total external cooling load which is made up with solar heat gain through external walls, roof, floor and windows. Figure 5.28 is a block definition diagram that describes the constraint blocks of internal cooling load from indoor lights, people and appliances.

Figure 5.29 and 5.30 are packages of block definition diagram of external and internal loads respectively, which contain constraint blocks that defines expected characteristics of the cooling load. Each constraint block enables to stock data and the behavior of the systems through editor scripts. The top section of each shows the attribute or data elements, and the lower section display the parameters of the data.

In the package of bdd in the figure 5.29, the constraint blocks “walls cooling load constraint block, window’s cooling load, roof cooling load, solar heat gain through floor and cooling load of fenestration” store data (equations) of heat gain through external walls, windows, roof, floor and solar heat infiltration respectively, in which scripts (equation) are sampled from 5.26, and are edited in java language. The constraints block “total Qext” stores equation of total external cooling load that sums solar heat gain through external walls, roof, floor and fenestrations. Constraint blocks CLTDs store data of CLTDs of walls, window, roof, and floor respectively in function of the time. Scripts of CLTDs are edited in matrix form with times of the day from 1hour to 24hours.

In the package bdd internal cooling load figure 5.30, Constraints blocks “People cooling load, appliance cooling load and light cooling load” store data or equations of heat generated by building’s occupants, appliances and lights respectively. The equations of scripts are pickup from figure 5.28. Designation in lower section of each constraint blocks are the parameters of the scripts edited in each constraint block. Constraint block “Total internal load” the script is the summation of all internal loads.

Figure 5.31 is the simulatable parametric model of peak cooling load that describes the behavior of cooling load according to day time. Boundary property “input” regroups input parameters which their data values and designation are described by table 5.8. Boundary output regroups the output of the simulation in which, the

external cooling load ( $Q_{ext}$ ), the Internal cooling load ( $Q_{int}$ ) and the main output total cooling load ( $Q_{cool}$ ) are located. Input and output boundaries are linked by connectors via constraint property blocks in which defined constraint blocks are reloaded. Constraint property block receives the input data from input boundary, operates according to the scripts (Code) of constraint blocks and plots the output. Constraint property block is the main mechanism of the simulation which enables simulations.

Blocks “wall, window, roof, floor and  $Q_{fes}$ ”, between input and output boundaries are constraint properties in which the constraint blocks “walls cooling load constraint block, window’s cooling load, roof cooling load, solar heat gain through floor and cooling load of fenestration” are reloaded to simulate solar heat gain through the building envelope.

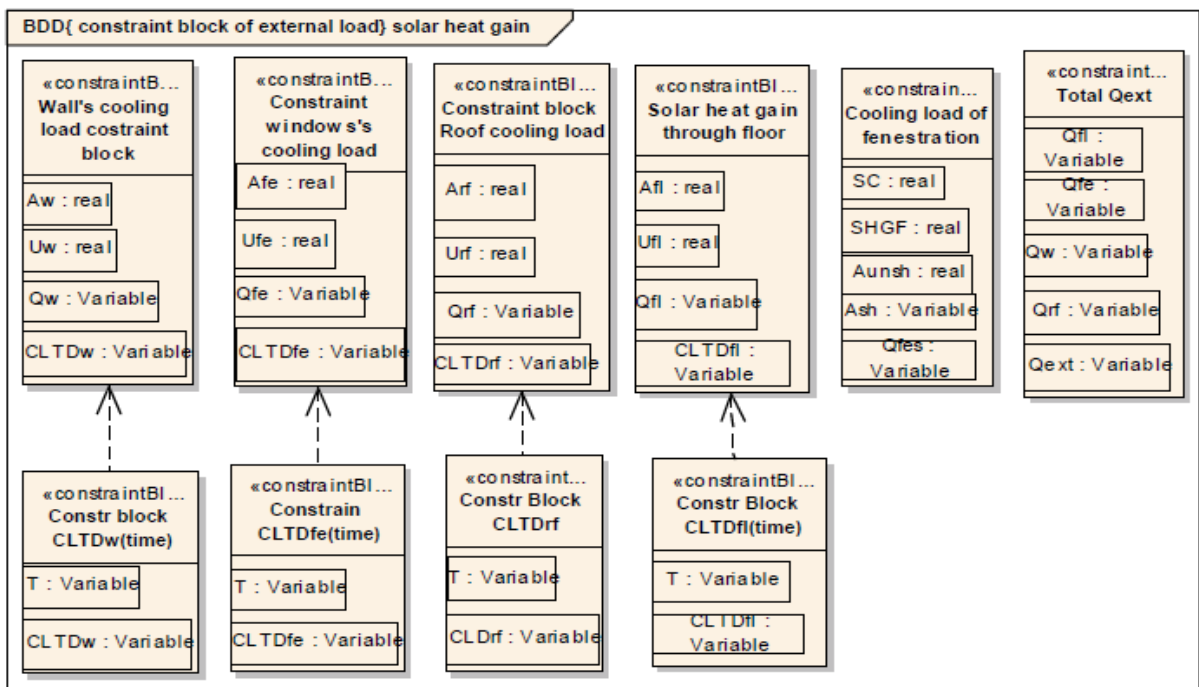


Figure 5.29: BDD showing constraint blocks for external cooling load



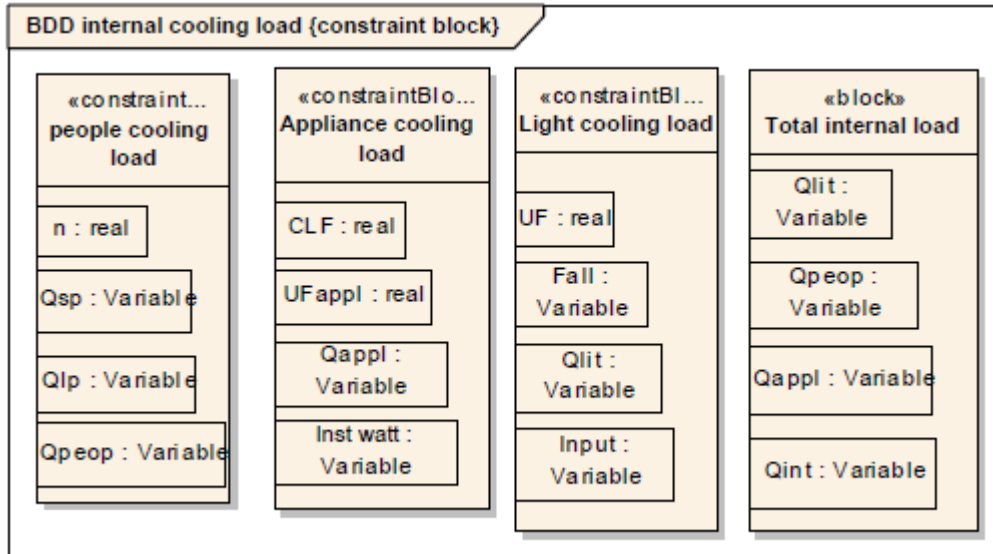


Figure 5.30: BDD showing constraint blocks for internal cooling load

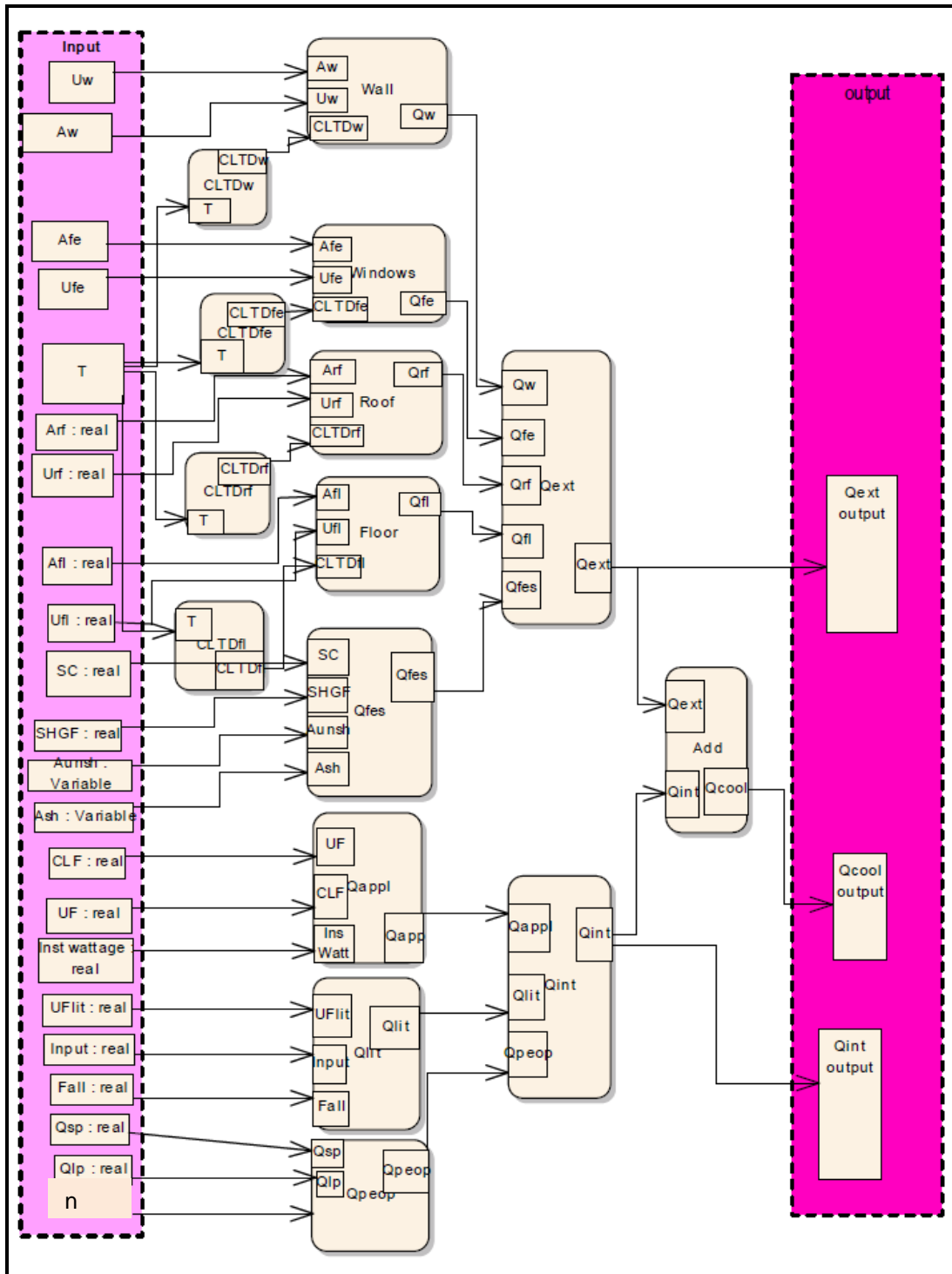


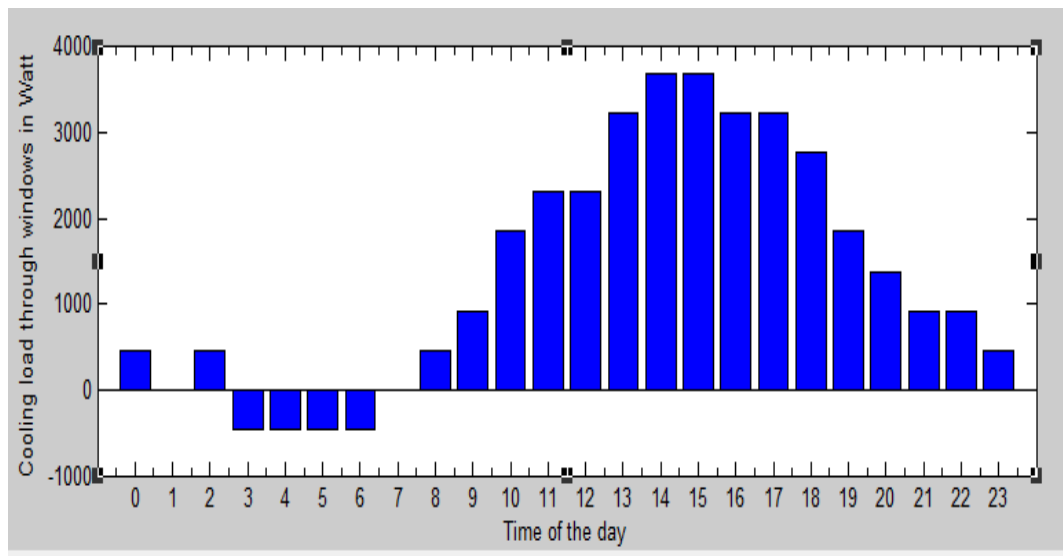
Figure 5.31: Parametric model for simulating total cooling loads for the building

**Table 5.8: Series of Data base used as input in the Figure 5.31 for cooling load simulation**

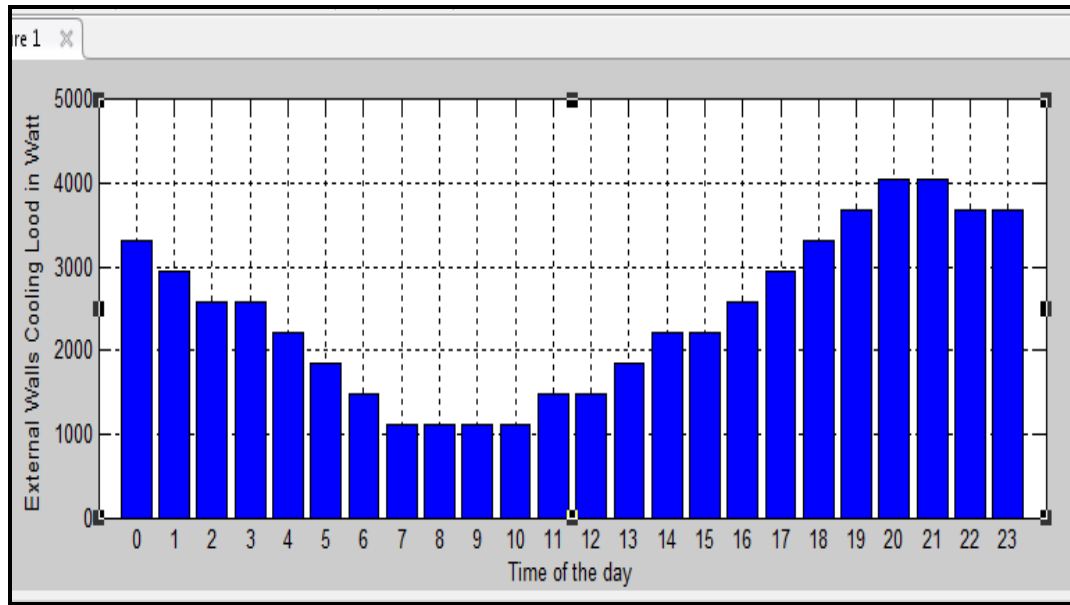
<b>Symbols</b>	<b>Designation</b>	<b>values</b>
Uw	Is U-value of external wall	The value is sampled from table 4.5. that is ( <b>Uw= 0.52 W/m<sup>2</sup>K</b> )
Aw	Is surface area of external wall	The value is sampled from table 4.6 that is ( <b>Aw=709m<sup>2</sup></b> )
Afe	Is surface area of total windows	The value is sampled from table 4.6( <b>Afe=81m<sup>2</sup></b> )
Ufe	Is U-value of total windows	The value is sampled from table 4.6( <b>Ufe=5.7 W/m<sup>2</sup>K</b> )
Arf	Is surface area of roof	The value is sampled from table 4.6( <b>Arf=312m<sup>2</sup></b> )
Urf	Is U-value of roof	The value is sampled from table 4.6( <b>Urf=0.27 W/m<sup>2</sup>K</b> )
Afl	Is surface area of floor	The value is sampled from table 4.6( <b>312m<sup>2</sup></b> )
Ufl	Is U-value of floor	The value is sampled from table 4.5 ( <b>Ufl=1 W/m<sup>2</sup>K</b> )
SC	Is shading coefficient of glass	The value is sampled from table 4.6( <b>SC=1</b> )
SHGF	Is solar Heat Gain Factor	The value is sampled from table 4.6( <b>SHGH=190 W/m<sup>2</sup></b> )
Aunsh	Is unshaded surface area of the window's glass	<b>Aunsh= 10m<sup>2</sup></b>
Ash	Is shaded surface area of window's glass	<b>Ash= 80m<sup>2</sup></b>
CLF	Is cooling load factor	The value is sampled from ASHAREA hand book ( <b>CLF=1</b> )
UF	Is usage factor of the building appliances	The value is assumed <b>UF=1</b>
Inst Wattage	Is the installation wattage of appliances frequently used	The value is <b>4000 W</b>
UFlit	Is usage factor of the lights	The value of ( <b>UF=1</b> )
Fall	Special allowance factor for fluorescent (ballast loss)	The value is sampled from ASHAREA hand book ( <b>Fall=1.30</b> )
Input	Total light wattage for light for all fixture	<b>11W . 300=3,300 W</b>
Qsp	Sensible cooling load per person multiplies per people	<b>60W. 30= 1800W</b>
Qlp	Latent cooling load per person times number of occupant	<b>40W. 30= 1200W</b>
T	Time of the day from 1h00 to 24h00	Is the solar time of the day
CLTDw	Cooling load temperature difference of external walls, roof, and window	The values were sampled from ASHAREA table

Block constraint properties CLTDs in which the input are the time of the day and output the variable CLTDs in function of day time that were tabularized by ASHAREA. The blocks “Qpeop, Qlit, and Qappl” are constraint property blocks which the simulation mechanisms are set up with equations of cooling load generated by people, lights and appliances respectively. Q extconstraint property block is the mechanism for simulating external load.

Table 5.8 describes the number of data collected from the building used as input for simulations, which may be set to the parametric model Figure 5.31, in order to simulate cooling and heating loads. With that parametric model figure 5.31 it is possible to simulate the load of each building’s element such external wall, roof, floor, and windows cooling loads. Regarding building’s elements, for our experimentations we did simulate only the external walls, windows and external cooling loads. In the Figure shown below, are the results obtained from cooling load simulations.

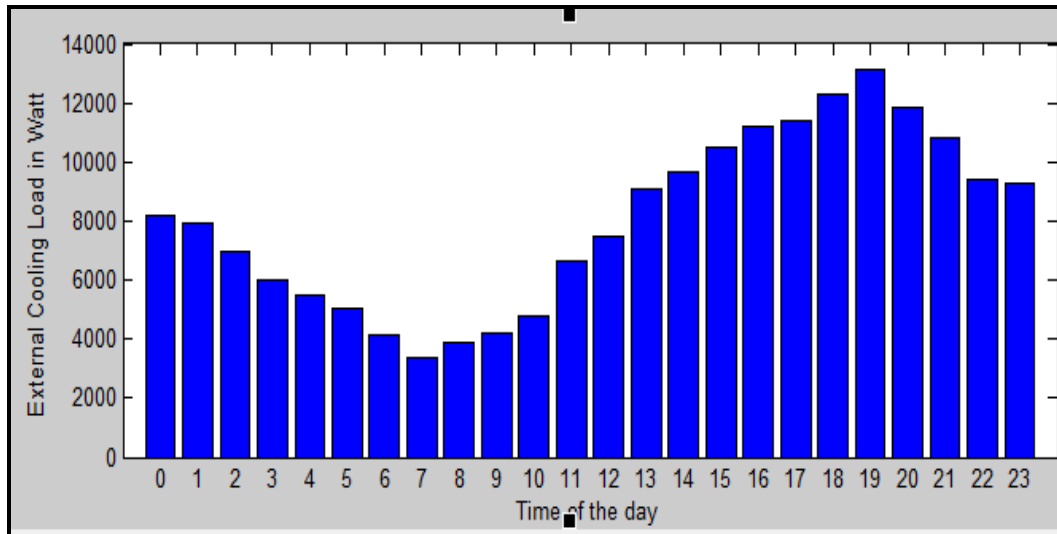


**Figure 5.32: Solar heat gains through fenestration or windows cooling loads simulation**

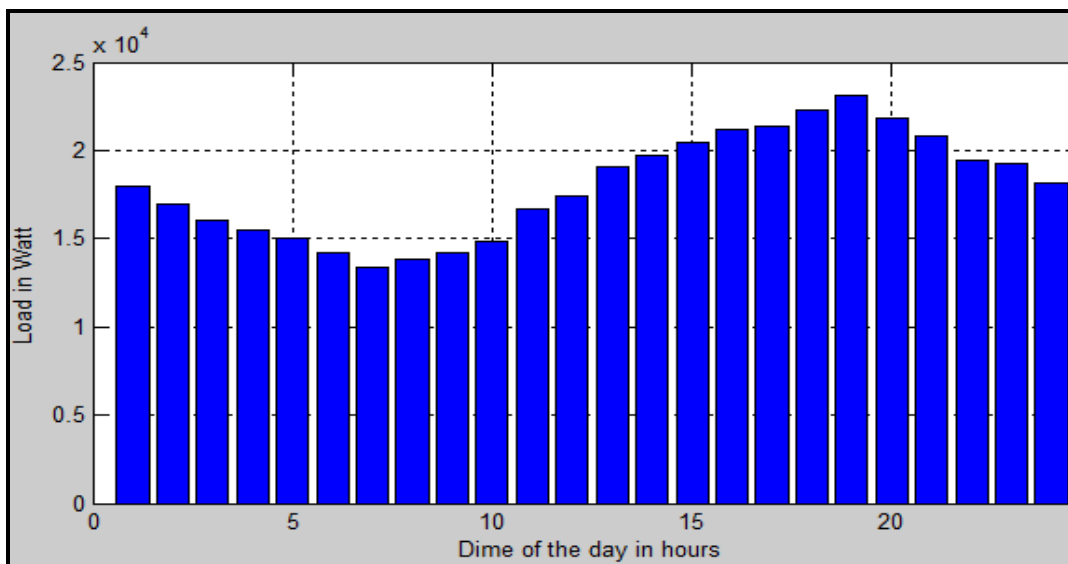


**Figure 5.33: Solar heat gains through external walls, daily cooling load of external walls**

According to the result got from simulation about total solar heat gains through fenestration as shown in Figure 5.32. It is noticeable that the peak cooling load of fenestration occurs almost at the same time with the peak intensity of solar radiation at noon. That means, glazed surface transfers solar heat directly into the building by conductive, convection and radiation. By analyzing the behavior of windows face to solar radiation as shown in Figure 5.32, the glazed surface transfers directly a big portion of solar heat into the building, reflects back small portion and the glass absorbs the remaining portion which will be released into the building later at sunset. Later around midnight when it is cold outside, the glass absorbs heat from indoor and releases it outdoor. Windows contribute significantly to the heating load; proper design of fenestration can reduce heat transfer, as resulting in the decreasing of the cooling load.



**Figure 5.34: Total external cooling load that is the sum of heat gains through roof, floor and total heat gains through external walls and fenestration**



**Figure 5.35: Peak total daily cooling load of the building simulation's result**

Figure 5.34 is the result of simulation for total solar heat gains through external walls and door. By analyzing the behaviour of the external walls concerning solar heat gain transfer, the peak load does not occur at the same time with the peak intensity of solar radiation. If the outdoor temperature is maximal at noon, the indoor temperature reaches the peak sometime in the evening. That is due to the time that heat takes to cross the compact bricks of the walls, that time is called “time lag”.

Figure 5.34 is the total external cooling load, however, Figure 5.35 is the total daily cooling load of the building that the lowest load occurs around 5am to 7am, and the load reaches the peak around 6pm to 8pm. By analyzing total daily external load and total cooling load obtained from simulations as shown in Figures 5.34 and 5.35 respectively, both loads are influenced by effect of time lag. According to the results got from simulations of cooling load, the cooling load of the building is about 74 W/m<sup>2</sup>.

### 5.3.2 Heating load

The peak heating load is the sum of peak heat lost to the outdoor environment at design outdoor and indoor conditions, which must be made up by the HVACs system to provide comfortable indoor temperature and IAQ for occupants. The total estimated heat loss is a combination of the sensible heat loss through conduction, infiltration and ventilation loads, (Burdick, 2011). In this stage the solar gain and the heat produced by internal devices are not taken into account, because those two factors contribute to the reduction of heating loads. The losses occur through building's envelope such as; exposed walls, roof ceiling, basement floors, windows, doors, attic new walls and bellow grade walls.

The heat loss that creates heating load is made up with heat transmission losses through the confining building envelope and the infiltrations through cracks and openings such as doors and windows.

#### 5.3.2.1 The heat transmission

Heat transmission loss is the heat loss by conduction and convection transfer through any surface of the building envelope (walls, windows, roof, ceiling and basement floor) as described by internal block definition diagram heat loss/heating load calculation Figure 5.39. The total heat loss is mathematically given by:

$$Q = AU(T_i - T_o) \quad (5.28)$$

Where  $Q$  is the heat transfer through wall, window, roof ceiling and floor,  $A$  is the surface area  $U$  is heat transfer coefficient for any surface of the building envelope,  $T_i$  is the indoor temperature and  $T_o$  is the outdoor temperature.

### 5.3.2.2 Infiltration loss

The heat loss due to infiltration is divided into sensible and latent losses. The sensible loss is expressed as:

$$Q_{sb} = V \rho c_{pa} (T_i - T_o) \quad (5.29)$$

Where  $Q_{sb}$  is the infiltration loss,  $V$  is volumetric air flow rate,  $c_{pa}$  specific heat capacity of air at constant pressure. The latent loss is expressed as:

$$Q_{ia} = V_p (W_i - W_o) h_{fg} \quad (5.30)$$

Where  $Q_{ia}$  is latent loss,  $V$  is volumetric air flow rate,  $W_i$  is the humidity ratio of indoor air and  $W_o$  is the humidity ratio of outdoor air.

Normally heat loss due to infiltration is the entry into the building of uncontrolled cold and dry wind through cracks in envelopes of the building, opened doors and windows. That means the internal environment (hotter) exchanges the temperature with the external environment (colder).

Total heat loss is the sum of total heat loss through the external walls, total heat loss through windows, heat loss through the roof and heat loss through the floor. Figure 5.36 is the bdd of total heat loss that expresses mathematically through constraint blocks total heat loss or total heating load, where as figure 5.39 is the internal block diagram of heat loss or heating load that explain through blocks and connectors the heat flow from the HVAC system that provides heat into the conditioned space of the building during the cold season, the heat escapes from the inside of the building through the roof, floor, external walls and windows.

The total heat loss through external walls is the sum of conductive heat loss through walls and doors, total sensible and latent heat loss through cracks and opened doors. The constraint blocks in block definition diagram of heat loss through external walls Figure 5.37, express mathematically the total heat loss through external walls. Regarding heat loss through windows, it is made up with conductive heat loss through windows, total sensible and latent heat loss through opened windows, as described mathematically on bdd total heat loss through windows as shown in Figure 5.38.



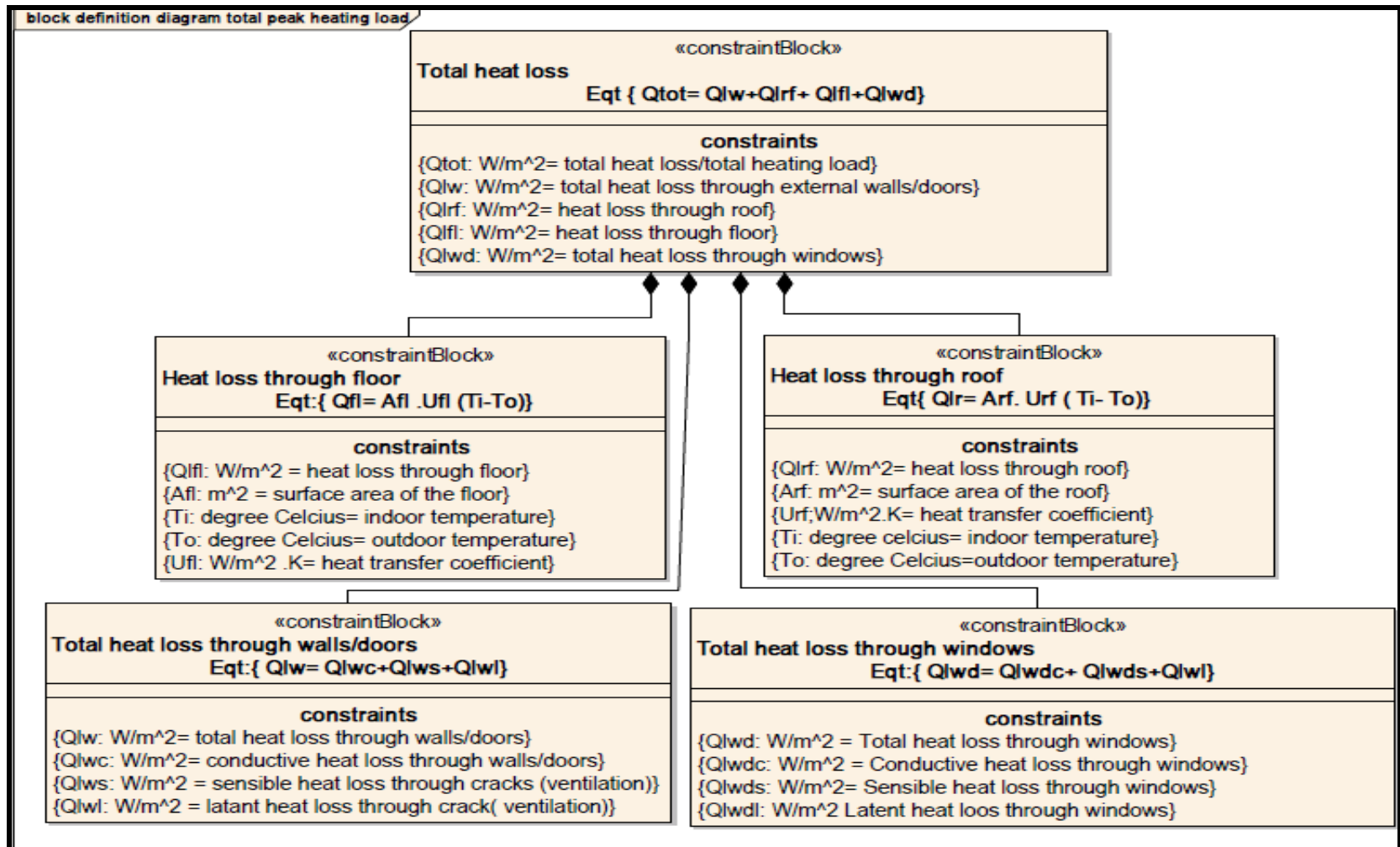


Figure 5.36: Block Definition Diagram of total heating loads

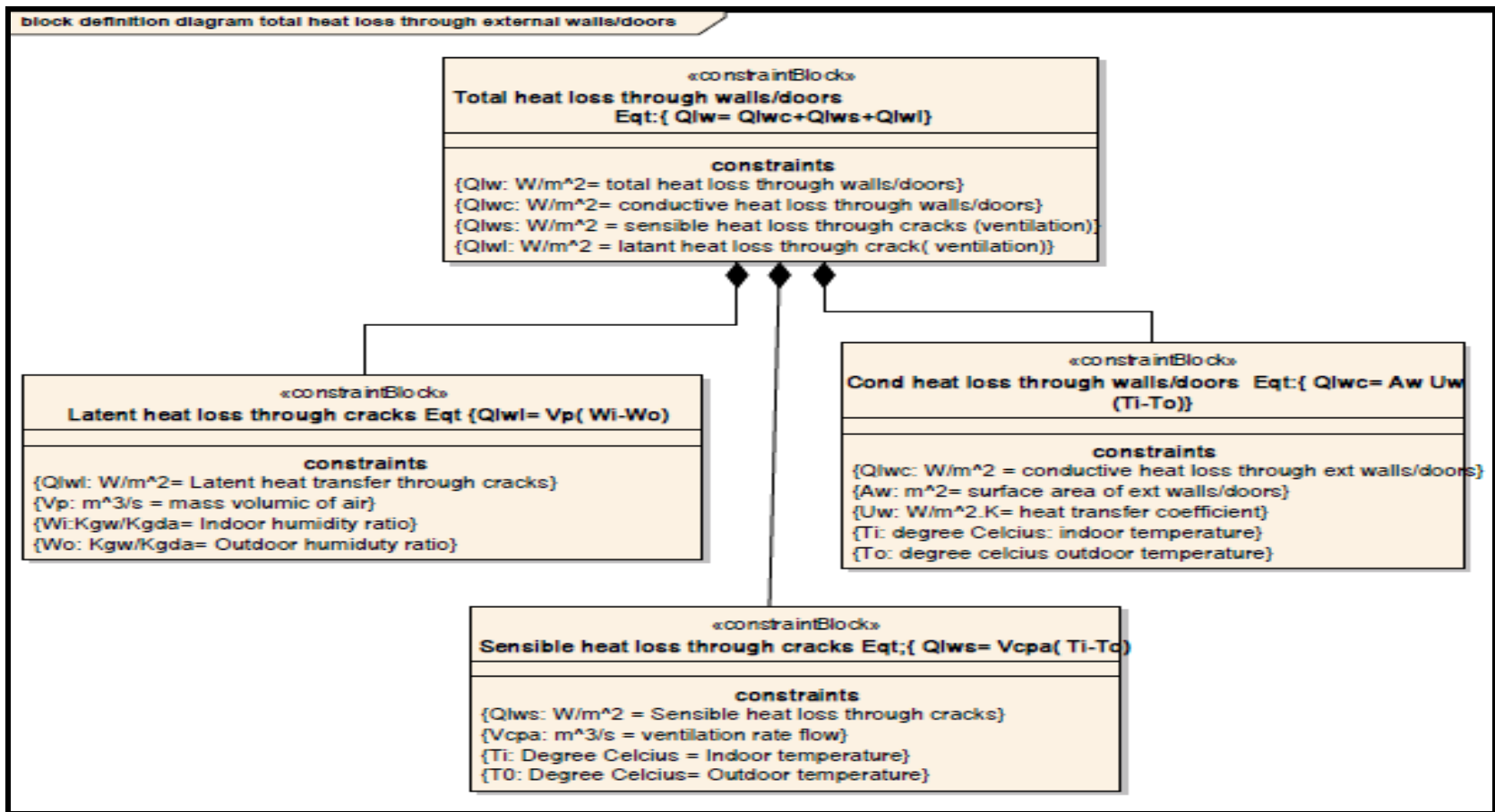


Figure 5.37: Block Definition Diagram of total heat loss through external walls and doors

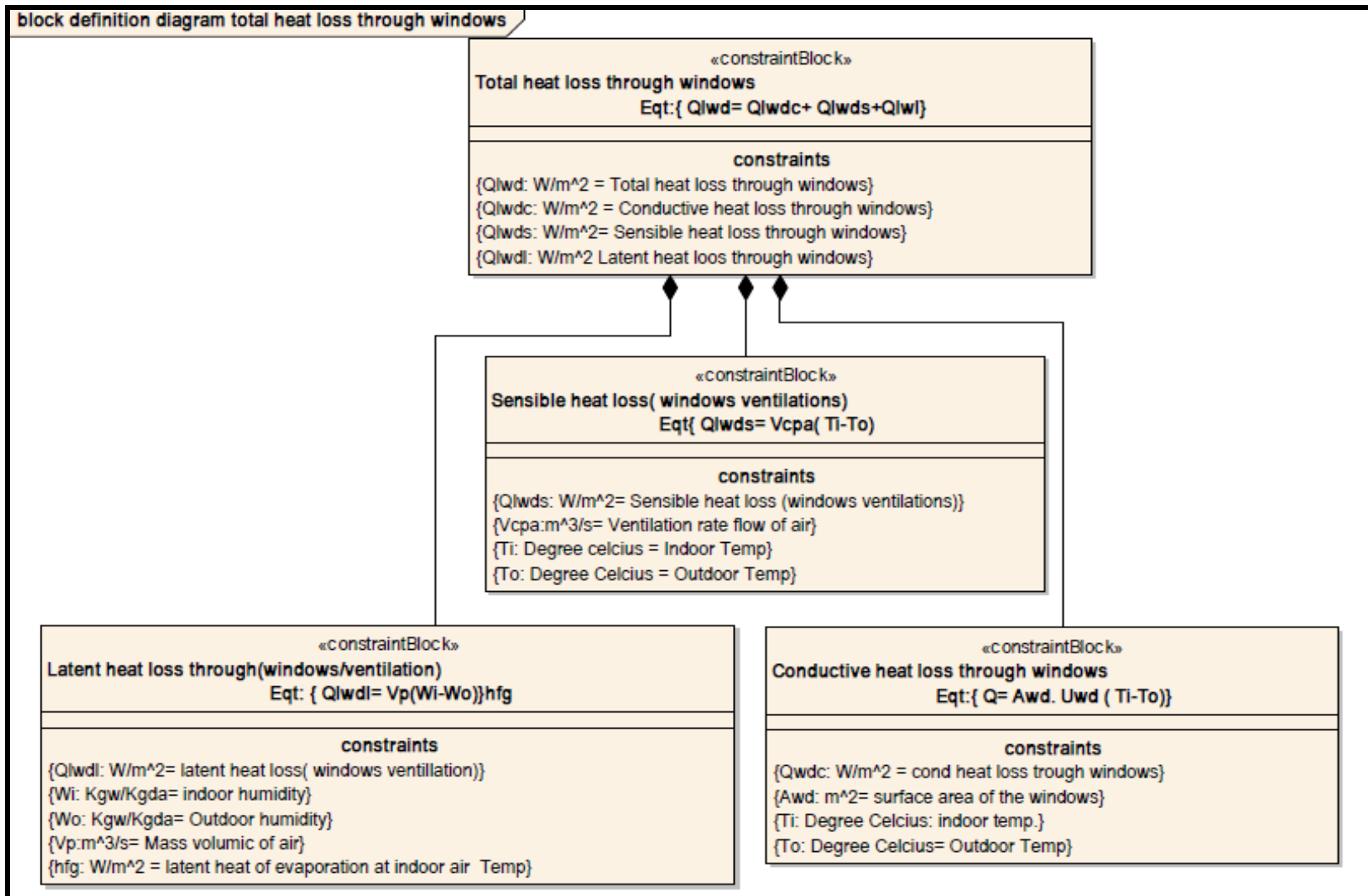


Figure 5.38: Block Definition Diagram of heat loss through windows

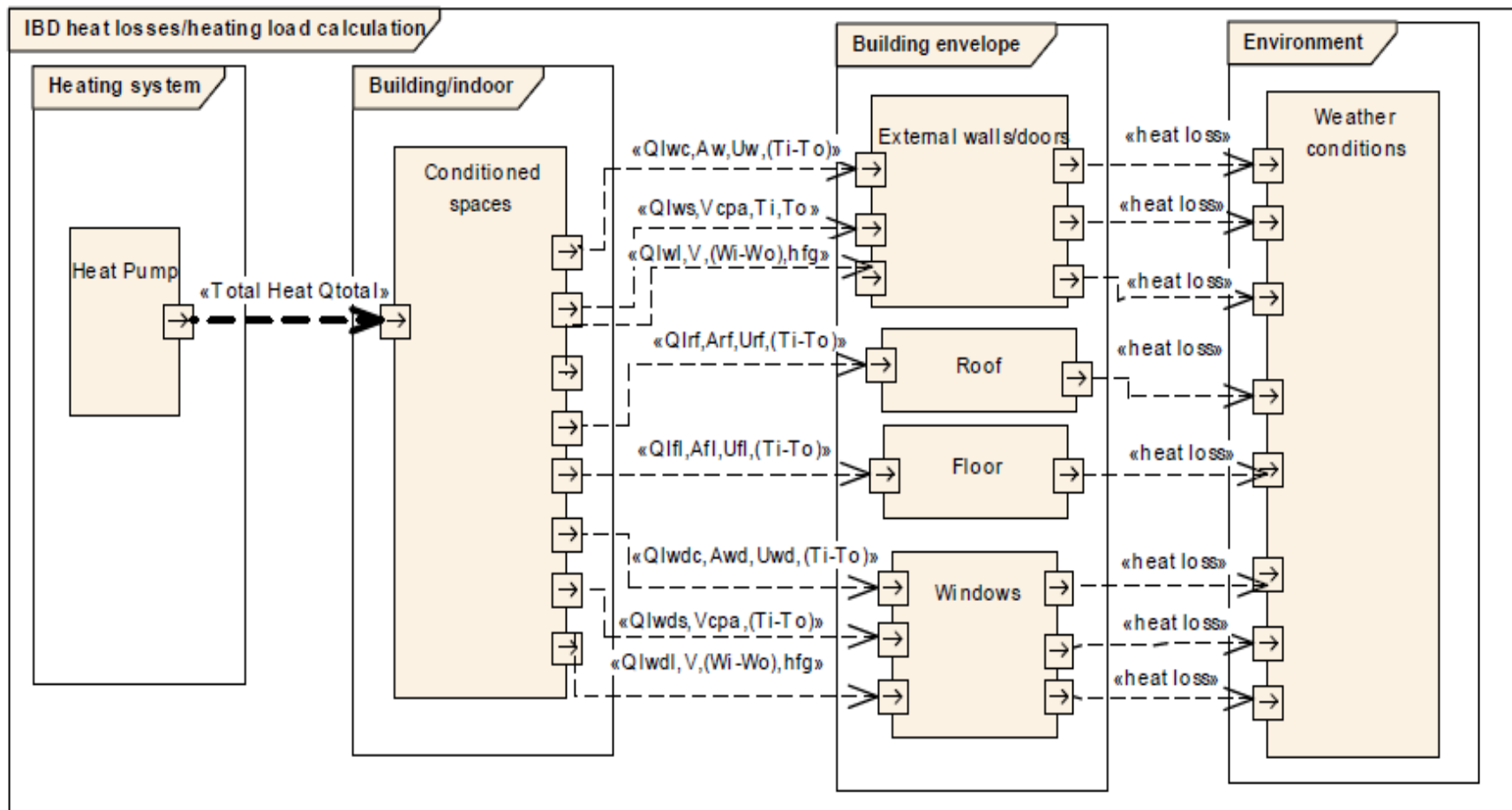
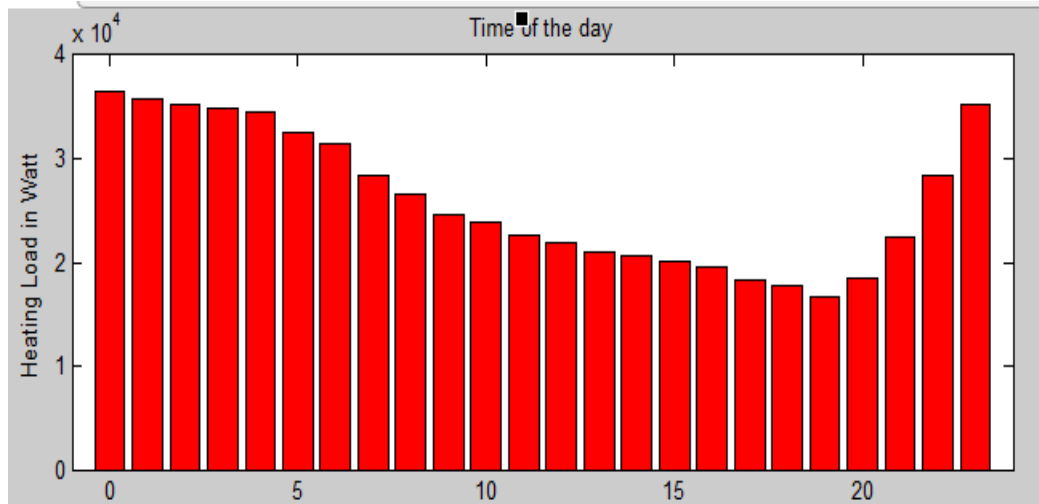
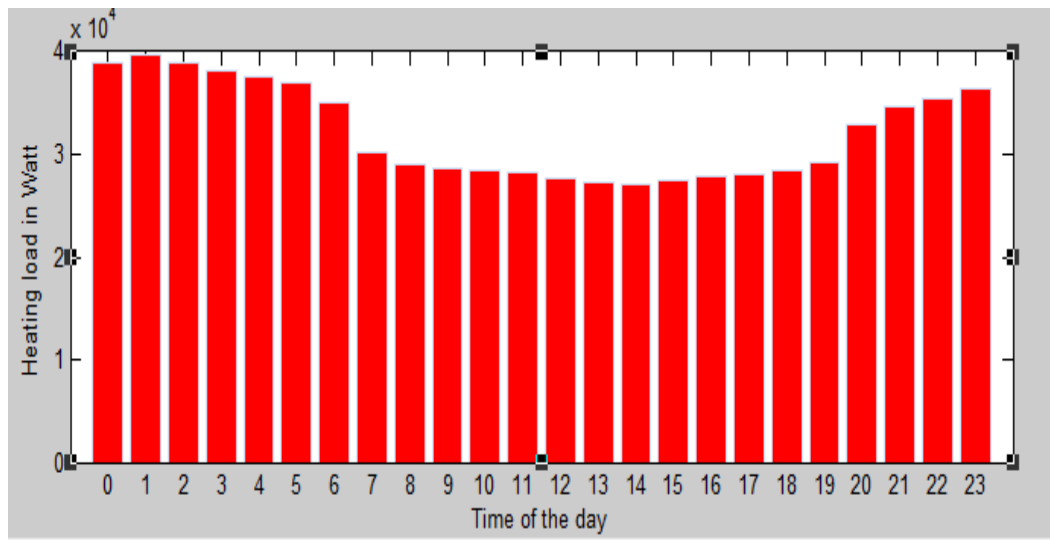


Figure 5.39: Ibd describes heat loss through the building envelope

For heating load simulation, the same methods as cooling load simulations have been used. That is to say the same parametric model has been used as cooling load simulation, but the CLTDs have been replaced by the different temperature between the indoor temperature and the outdoor temperature, in the input boundary the input data blocks of cooling load have been replaced by the input data blocks of heating load, constraint blocks of cooling load have been replaced by constraint blocks of heating load, which are reloaded in the constraint property blocks of heating load's parametric model. In the output boundary, the cooling load output blocks have been replaced by output heating load. Figures 5.40 and 5.41 shown below are the results of heating load simulations.



**Figure 5.40: Total daily heating loads during of the sunny day in winter season**



**Figure 5.41: Total daily heating load in June and July**

For heating load calculations, the internal loads are not taken into account. Nevertheless the internal heat source contributes to the mitigation of heating load. Heating loads calculations, heat losses through the building envelope are calculated by using the same equations used in cooling load calculation processes for heat gain

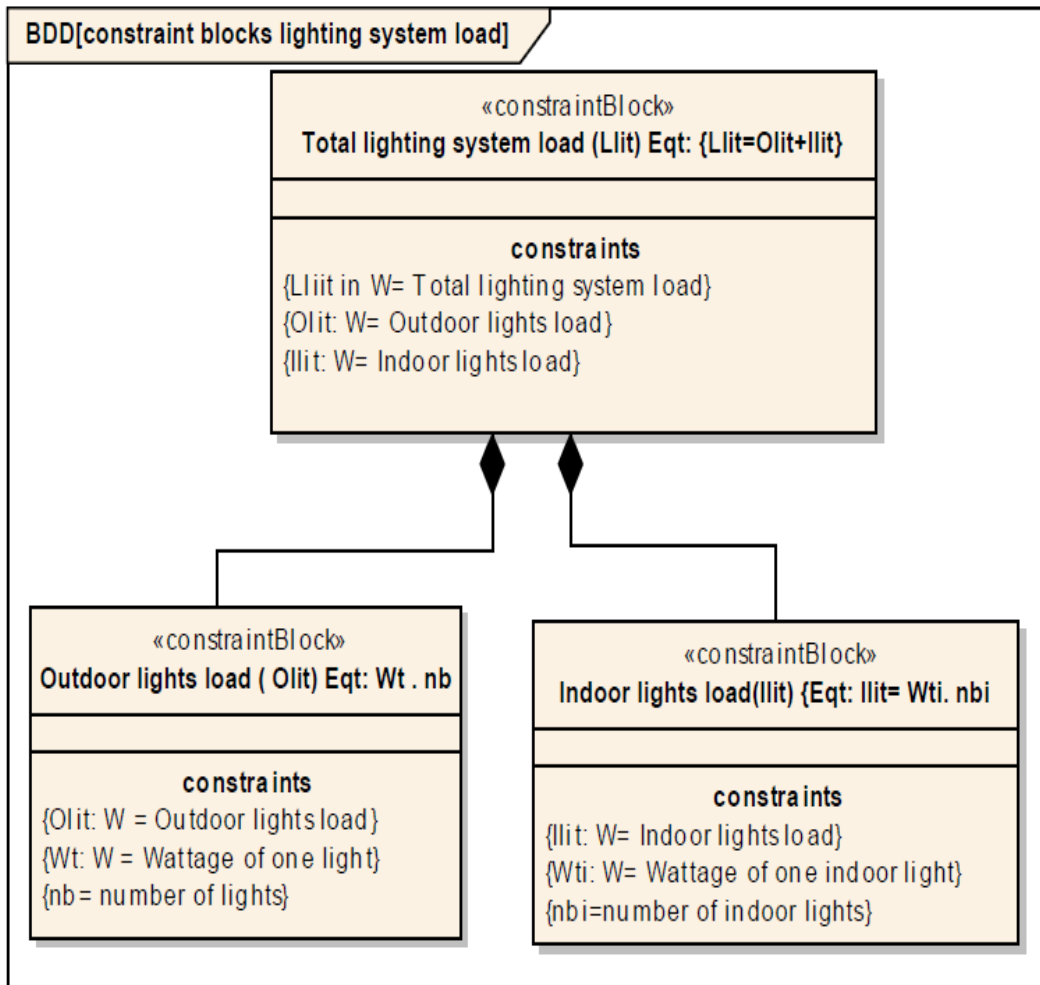
through the building envelope. In such a case CLTD is replaced by design temperature difference between the conditioned spaces and outdoor.

For heating load, simulations have been based on two days sampled from winter season. Data of the first simulation have been sampled from the sunny day when winter is not too heavy, and the data of the second simulation shown in Figure 5.41 have been sampled from worst case day when the temperature drops to the lowest temperature of winter period especially in June and in July. In the sunny day, heating load decreases as shown in Figure 5.40. For the sunny day, the decreasing of the load is due to the solar heat gain; moreover the dip load occurs in the evening around 6pm to 7pm because of the time lag of solar heat gain. For a cloudy day in Figure 5.41 the load is higher during the night and lower during the day, because generally in winter the outdoor temperature drops during the night. According to the simulation, the average heating load of the building is about  $110\text{W/m}^2$ ;

#### **5.4 Lighting system load simulations**

As explained previously, lighting system contributes significantly to the building energy consumption. After the investigation about lighting system to the building's occupants, we have noticed that most of building occupants are using incandescent lamps for indoor lighting, which the wattage ranges between 75W to 100W, and some of occupants fail to manage light utilization.

Figure 5.42 is the block definition diagram that describes constraint block which could allow to calculate and to simulate lighting system loads. Table 5.9 describes the attribute of no-automated building's lighting system in which occupants are using incandescent lamps. Tables 5.9 and 5.10 describe the characteristic of no-automated and automated building's lighting systems. In automated building only LEDs or CFLs have been used, and the daily ratio of operating. Figures 5.43; 5.44; 5.45; 5.46; and 5.47, are the results of lighting system load's simulations.



**Figure 5.42: BDD describing constraint blocks of lighting system**

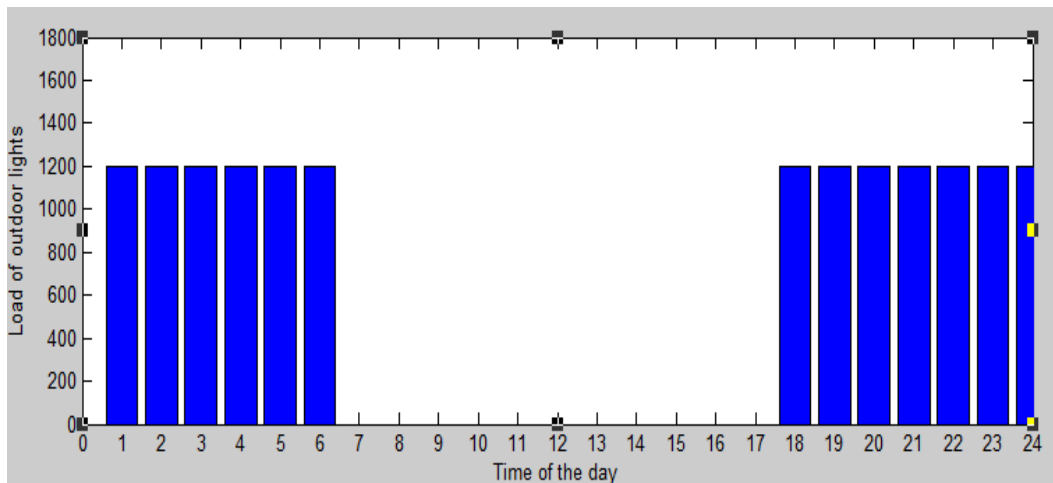
**Table 5.9: Description of lighting systems' characteristics, and the ratio of working per hour to no automated building**

Time of the day	Outdoor lights ratio of operation in percentage per hour	Indoor lights ratio of operation in percentage per hour
	Number of lights: 30	Number of lights: 75
	Wattage :40W	Wattage: 75 W
1hour	100%	10%
2hour	100%	10%
3hour	100%	10%
4hour	100%	10%
5hour	100%	10%
6hour	100%	10%
7hour	0%	20%
8hour	0%	20%
9hour	0%	20%
10hour	0%	20%
11hour	0%	20%
12hour	0%	20%
13hour	0%	20%
14hour	0%	20%
15hour	0%	20%
16hour	0%	20%
17hour	0%	20%
18hour	100%	100%
19hour	100%	100%
20hour	100%	100%
21hour	100%	100%
22hour	100%	100%
23hour	100%	10%
24 hour	100%	10%



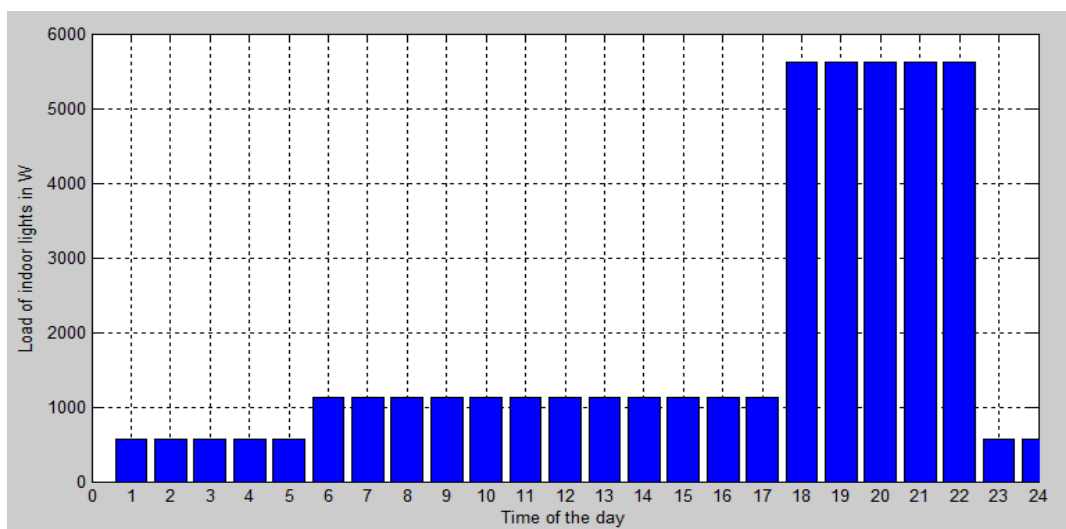
**Table 5.10: Describes lighting system characteristics, and ratio of operating to automated building using compact fluorescent lamps**

Time of the day	Outdoor lights ratio of operation in percentage per hour	Indoor lights ratio of operation in percentage per hour
	Number of lights: 30	Number of lights: 150
	Wattage :40W	Wattage: 11 W
1hour	100%	10%
2hour	100%	10%
3hour	100%	10%
4hour	100%	10%
5hour	100%	10%
6hour	100%	10%
7hour	0%	0%
8hour	0%	0%
9hour	0%	0%
10hour	0%	0%
11hour	0%	0%
12hour	0%	0%
13hour	0%	0%
14hour	0%	0%
15hour	0%	0%
16hour	0%	0%
17hour	0%	0%
18hour	100%	100%
19hour	100%	100%
20hour	100%	100%
21hour	100%	100%
22hour	100%	100%
23hour	100%	10%
24 hour	100%	10%



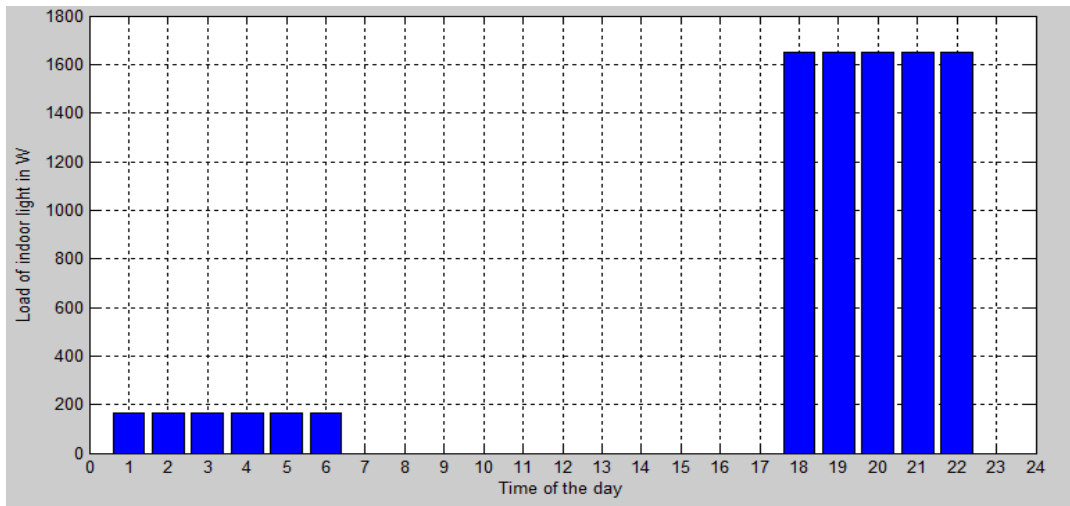
**Figure 5.43: Daily loads of outdoor lights connected to the daylight detectors**

Figure 5.43 is the load of outdoor light of no-automated building, from 7am to 5pm lights are off the load is nil, and from 6pm to 6am during the night lights are on the load is maximal. The system is using Fluorescent Lamps of 40W. The outdoor light sub-system is linked to the day light detectors.



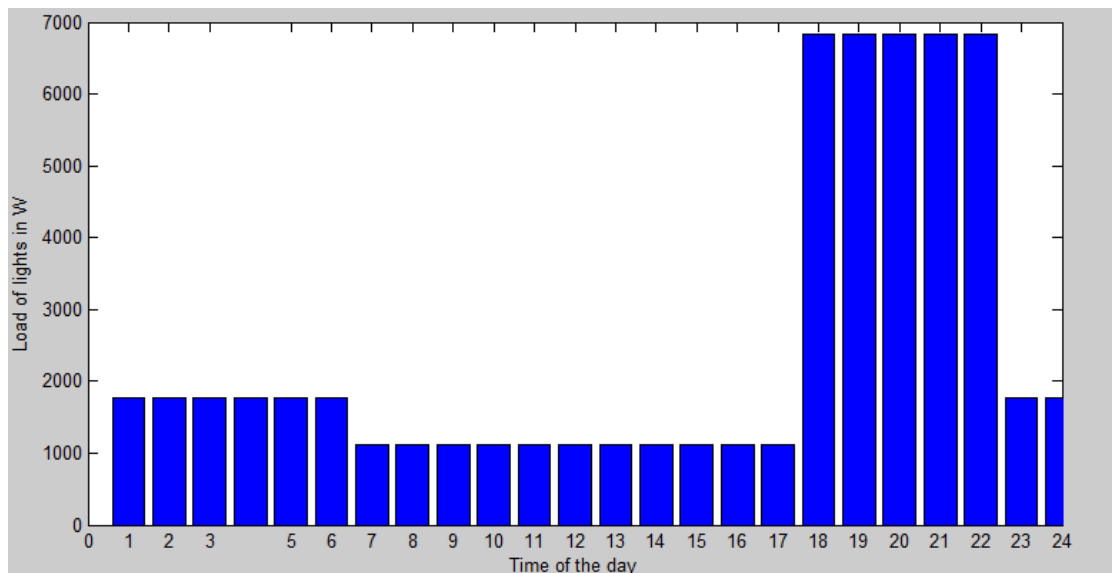
**Figure 5.44: Daily loads of indoor lights for no-automated building using incandescent lamps**

Figure 5.44 is the load of indoor lights of no-automated building using incandescent lamps. By analyzing the shape of the curve, it is noticeable that the load is maximal from 6pm to 10pm when occupants are seated, and working, from 11pm to 6am the load is minimal because occupants are sleeping some of them switch off all apartment lights. From 6am to 5pm the load raises a bite, because occupant wake up and switch on some lights, in order to get ready to go out for their daily activities (school and work). According to the investigation, most of the occupants forget to switch off lights when they are rushing to go out. That is why the load is permanent.



**Figure 5.45: Daily loads of indoor lights for of automated building using CFLs lamps**

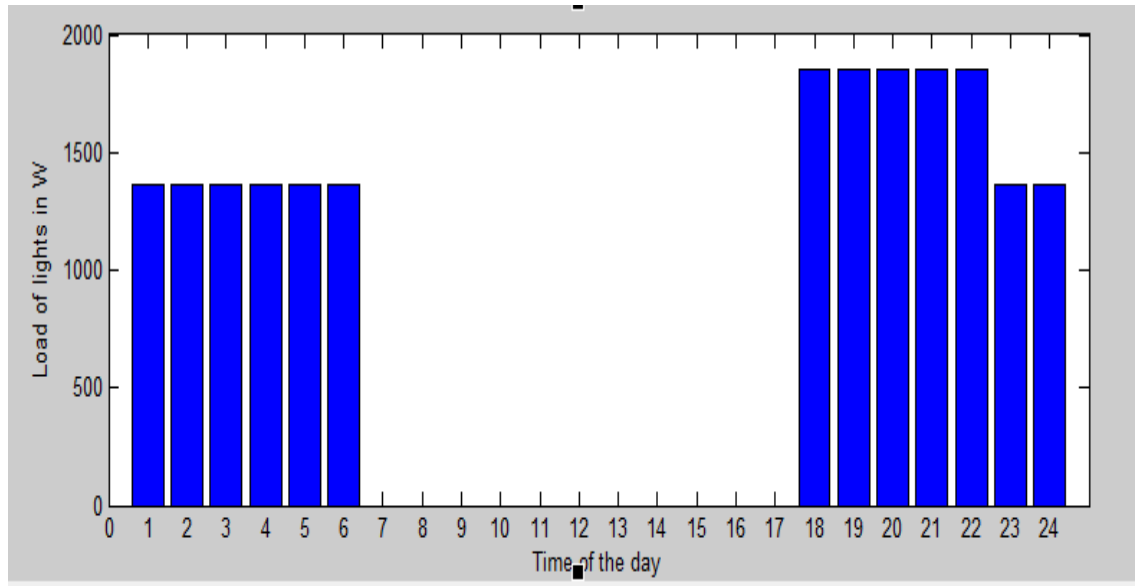
Figure 5.45 is the load of indoor lights of the automated building using CFLs. The indoor light is controlled by automation system. From 8am when the occupants leave the building for their daily activities, automation system switch off all indoor lights and the load becomes nil. We assume that everybody leaves the building during the day. The load is maximal from 6pm to 10pm when everybody is back in the evening, and it is assumed that during that time everybody is in the building. The peak loads of indoor lights reaches 1650 W, however the peak load of no-automated building reaches 5625 W.



**Figure 5.46: Daily total loads of indoor and outdoor lights of non-automated building**

Figure 5.46 is the total light load of a no-automated building using incandescent lamps for indoor lights and fluorescent lamps for outdoor. The load is maximal when

both sub-systems are on from 6pm to 10pm. Figure 5.47 is the total lighting system load of automated building using CFLs lamps. By analysing the behaviour of both buildings, that means automated and no-automated, we notice that at the maximal load, the lighting's system load of no-automated building, is three times lighting's system load of automated building.



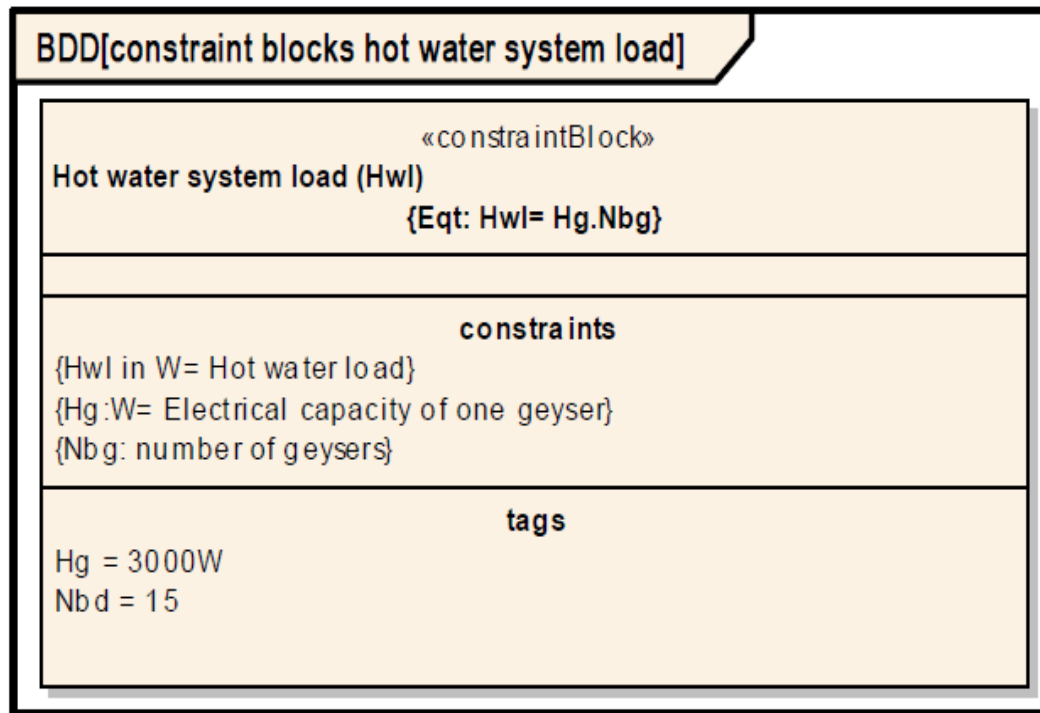
**Figure 5.47: Total daily lighting system load of automated building**

## 5.5 Hot water system load simulations

In the first chapter, we have emphasized that hot water system is one of the major consumers in the residential building. This system must be switched off when hot water is not needed, in order to optimize energy consumption, but most people do not switch off the geyser when not required. In general an electrical geyser has a thermostat, which is a device which continuously keeps the water in the geyser at a specific set point temperature. If the temperature drops below the set temperature, thermostat activates the heater until the temperature reaches the set point.

The main causes for a drop in temperature is when hot water has been used and the geyser fills up with cold water, when there is a heat leakage, and when the temperature of surroundings is lower.

Normally bathing consumes more hot water than showering; bathing uses about 40 liters of water per person, moreover showering uses 25 liters of water per person. According to the building occupants, they prefer to shower during the weekdays and bathing during the weekend.



**Figure 5.48: BDD describing constraint block of hot water system**

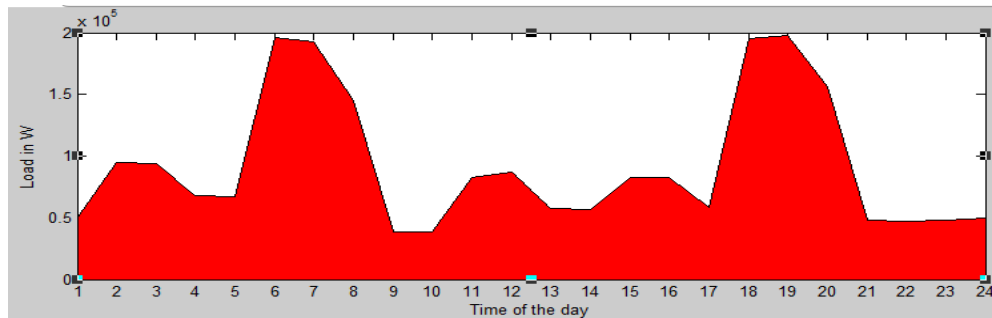
In winter, electrical geyser of no-automated building consumes more electricity than in summer. Due to the cold environment, the temperature of water takes more time to rise to the set point, and the temperature of hot water drop fast. According to the experimentations, electrical geyser shifts twelve times “on, off, on” and consumes about 15 to 18 KWh per day for one apartment and 270 KWh per day for the whole building. However in the automated building, electrical geyser is programmed to work two times a day or four shifts a day, in the morning before the peak demand time, and in the evening before the peak demand time. Thus electrical geyser in the automated building consumes 4 to 6 KWh per day for an apartment and 90KWh per day for the whole building.

In summer, electrical geyser of no-automated building consumes less energy because of the hot atmosphere, water gets warm faster than in winter when the geyser is switched on, and cools off slowly and gradually when the thermostat of the geyser is shut off. Whereas in the automated building, automation system switches on the geysers only in the morning, and solar geyser take over for the rest of the time. Thus in summer, all geysers of no-automated building consume 120 to 135 KWh per day, and automated building consumes 45 KWh per day.

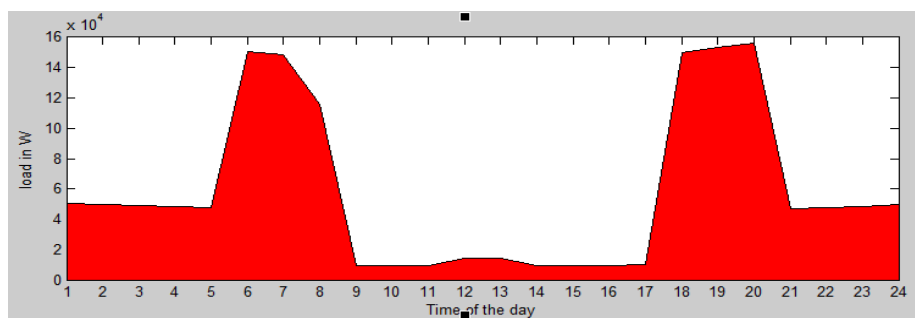
## **5.6 Building loads, automated building versus no-automated building**

In this stage, we are going to simulate the behavior of the total loads, for the same building with automation system and solar hot water system, and without automation

system in the same weather conditions, in order to compare them. The figures below are loads of the building obtained from simulations.

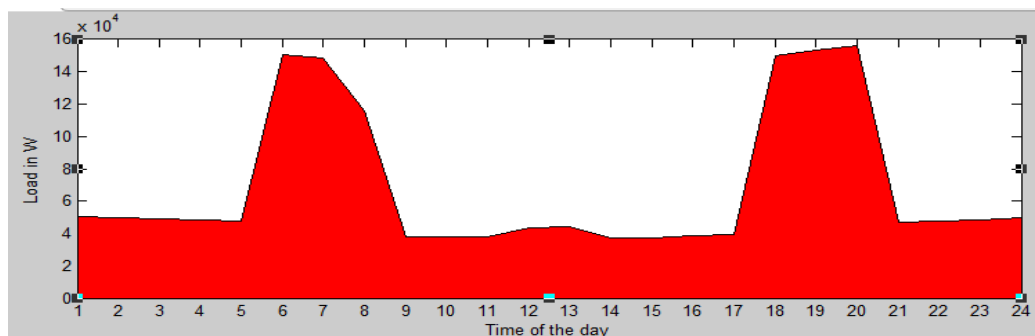


**Figure 5.49 Daily loads for a no-automated building in winter season**

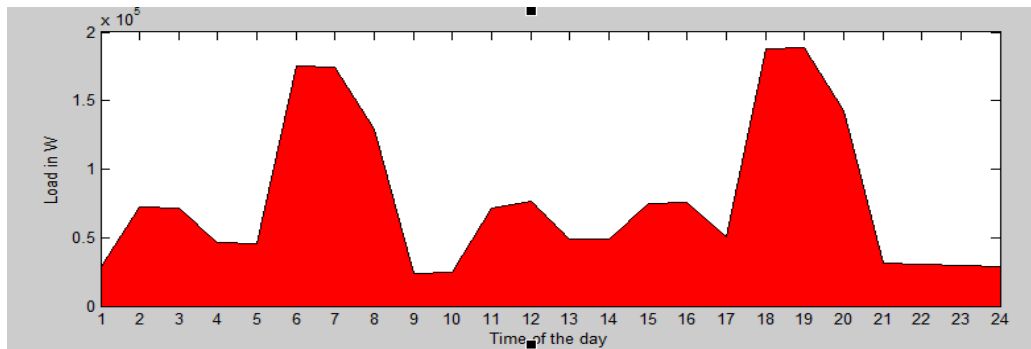


**Figure 5.50 Daily loads for automated building in the weekend day of winter season.**

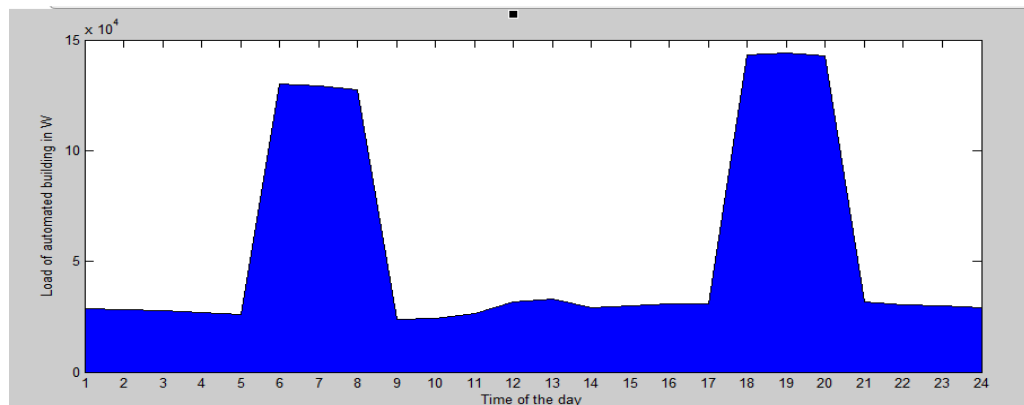
Figure 5.49 is the daily load of the no-automated building in winter season, which the peak demand occur in the morning from 6 am to 8am when occupants are busy washing, cooking breakfast and using other facilities to get ready for the routine activities, and in the evening between 6pm and 8mp. Furthermore large consumers of energy such as lighting, hot water and HVAC system go “on”. Between 11pm to 4am and 9am to 4pm, the load is shifting because of the geysers loads. The permanent load is due to the devices left “on” unintentionally and the fridges.



**Figure 5.51: Daily load of automated building in the weekdays of winter season**



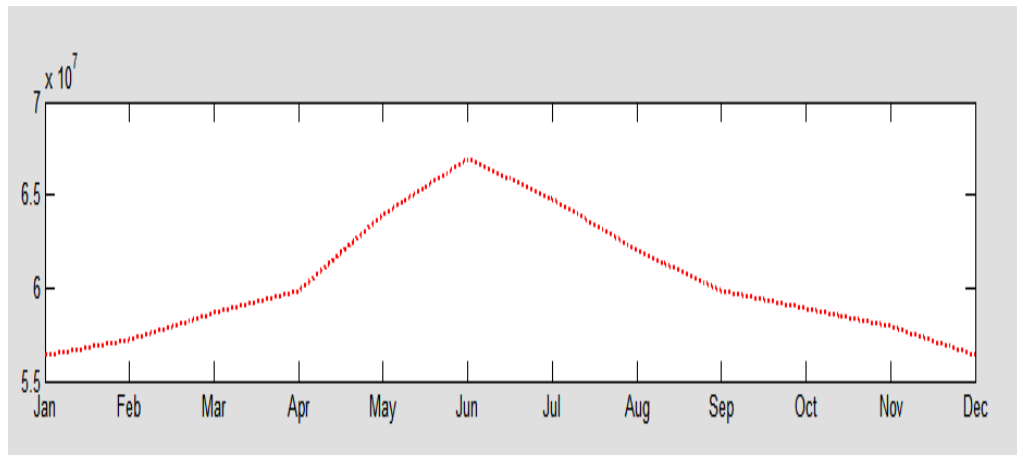
**Figure 5.52: Daily load of no-automated building in summer season**



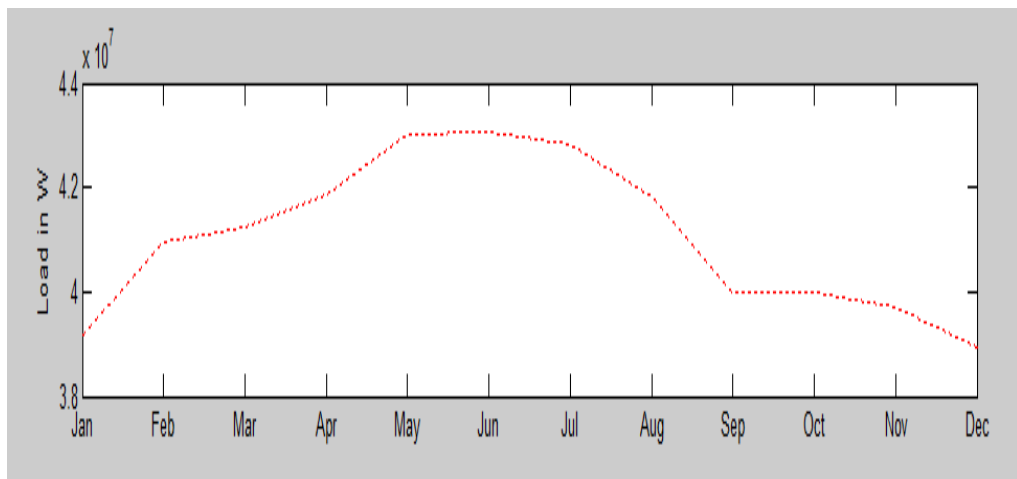
**Figure 5.53: Daily load of automated building in summer season**

Figure 5.50 is the daily load of the same building with automation system and solar hot water system. After the peak demand when everybody leaves the building, the automation system switches off all large consumers and the load drops to permanent loads, it assumes that there is nobody to the building. Figure 5.51 is the load of automated building in the weekend day; it assumes those occupants are at home during the all day. By comparing the daily and monthly energies consumed by automated building and no-automated building as shown in the table 5.11, the automated building saves about 717 KWh per day and 23900 KWh per month

Figure 5.52 and 5.53 below, are the daily loads of no-automated and automated buildings in summer respectively. The peaks loads reach 180000W or 180KW for no-automated building, and 140000W or 140KW for an automation building. By analysing the daily shapes of the curves, the energy demand in winter is higher than in summer season. The energy demand in winter is impacted by the heating load and devices with heaters.



**Figure 5.54: Yearly energy consumption of no-automated building**



**Figure 5.55: Yearly energy consumption of automated building**

Figure 5.54 and 5.55 are yearly energy consumption of automated building and no-automated building respectively. The peak loads of both figures occur in June and July. That period is the coldest period of the year and affects significantly the peak demand of energy.

By analysing the results of yearly energy consumption for both buildings as shown in figures 5.54 and 5.55. The shapes of curves for both figures vary according to the seasons. That is to say in winter season the consumption is higher than in summer season.



**Table 5.4 Description of daily and monthly energy consumptions for automated building versus no-automated building**

<b>Building state</b>	<b>Daily consumption per m<sup>2</sup></b>	<b>Monthly consumption per m<sup>2</sup></b>	<b>Yearly energy consumption per m<sup>2</sup></b>	<b>Yearly energy saving by the entire building</b>
<b>No-automated Building</b>	<b>1.447 KW</b>	<b>43.410 KW</b>	<b>520 KW</b>	–
<b>Automated building</b>	<b>0.889 KW</b>	<b>26.670 KW</b>	<b>320 KW</b>	<b>62400KWh</b>

Analysis of energy consumed by automated building versus a no-automated building. According to the results obtained from simulations, it is obvious that the energy consumed by no-automated building is much higher than the energy consumed by automated building. Table 5.4 describes the daily, monthly and yearly energy consumption for both buildings. The yearly energy consumption of no-automated building is 162240 KWh and 99840 KWh for automated building. Therefore automated building will be able to saving about 62400KWh per year.

## **CHAPTER SIX CONCLUSION AND DISCUSSION**

### **6.1 Introduction**

As the building energy modeling industry is facing a number of challenges such as complexity of the advanced methods, lack of accuracy for early design and existing buildings, this thesis has developed a new model in System Modeling Language (SysML) to predict annual energy consumption, and determine peak loads, at the same time set up automation system and solar hot water system to the existing building in order to meet energy efficiency. To simplify the simulation processes of cooling and heating loads in SysML, this thesis has opted for a Cooling Load temperature Different (CLTD) method, because this method is very simple to use and it is the most popular and widely used.

As SysML is a new modeling language that is very simple and can be used in Engineering System to overcome modeling challenges. So then this thesis was excited to deal with building energy modeling in SysML in order to overcome the energy modeling challenges such as: inaccuracy of heating and cooling load and the complexity of the system in the modeling processes.

### **6.2 Aims and objectives**

To solve the challenges of inefficiency of energy consumption in the building that affect climate change, the power supplier as well in South Africa. The project objectives were to mitigate energy consumption for existing and future buildings by developing a new energy model with aims:

- To provide good designs for future building during the planning process by targeting and breaking down the main causes of energy over-consumption
- To select efficient devices for large consumers of energy
- To set-up an automation system to the building for energy management and to monitor if the building is using efficient devices, in order to meet at the same time energy efficiency, convenient and comfort environment.
- To calculate the accurate cooling and heating load, in order to right-size the HVAC system.
- To set-up to the building other alternatives of energy such as solar energy for hot water system and lighting system in order to mitigate energy consumption

### 6.3 Discussion

After analysis and investigation developed by this project, it was concluded that the overconsumption was created by HVAC, lighting and hot water systems. Moreover, the consumption of energy by HVAC system is impacted by heating and cooling loads. The building envelope and building orientation have big impacts on heating and cooling load for building. Improving R-values of building envelope, and a good orientation will mitigate significantly heating and cooling loads. It is advised to use heat pump for HVAC system, however hot water produced by heat pump can be used for other purposes.

By analysing the results obtained from simulations, automated building is far more efficient than the no-automated building, and it makes occupants' life more comfortable and convenient. The big weakness of automation system is that the investment cost is very high, that is not affordable for common residential buildings; however it can be covered in a competitive time or pay-back period.

Solar energy can be another alternative to back-up the power supplier energy using solar equipment such as solar geyser, solar air conditioning system and tubular daylighting system will contribute to the high level energy efficiency. South Africa is in a good position to set up solar devices.

For building energy efficiency, the big targets are HVAC, Lighting and Hot water systems. Once they are broken down, the building can reach energy efficiency. Compact Fluorescent lamp for lighting systems and solar geysers for hot water system contribute significantly to high level energy efficiency for complex buildings.

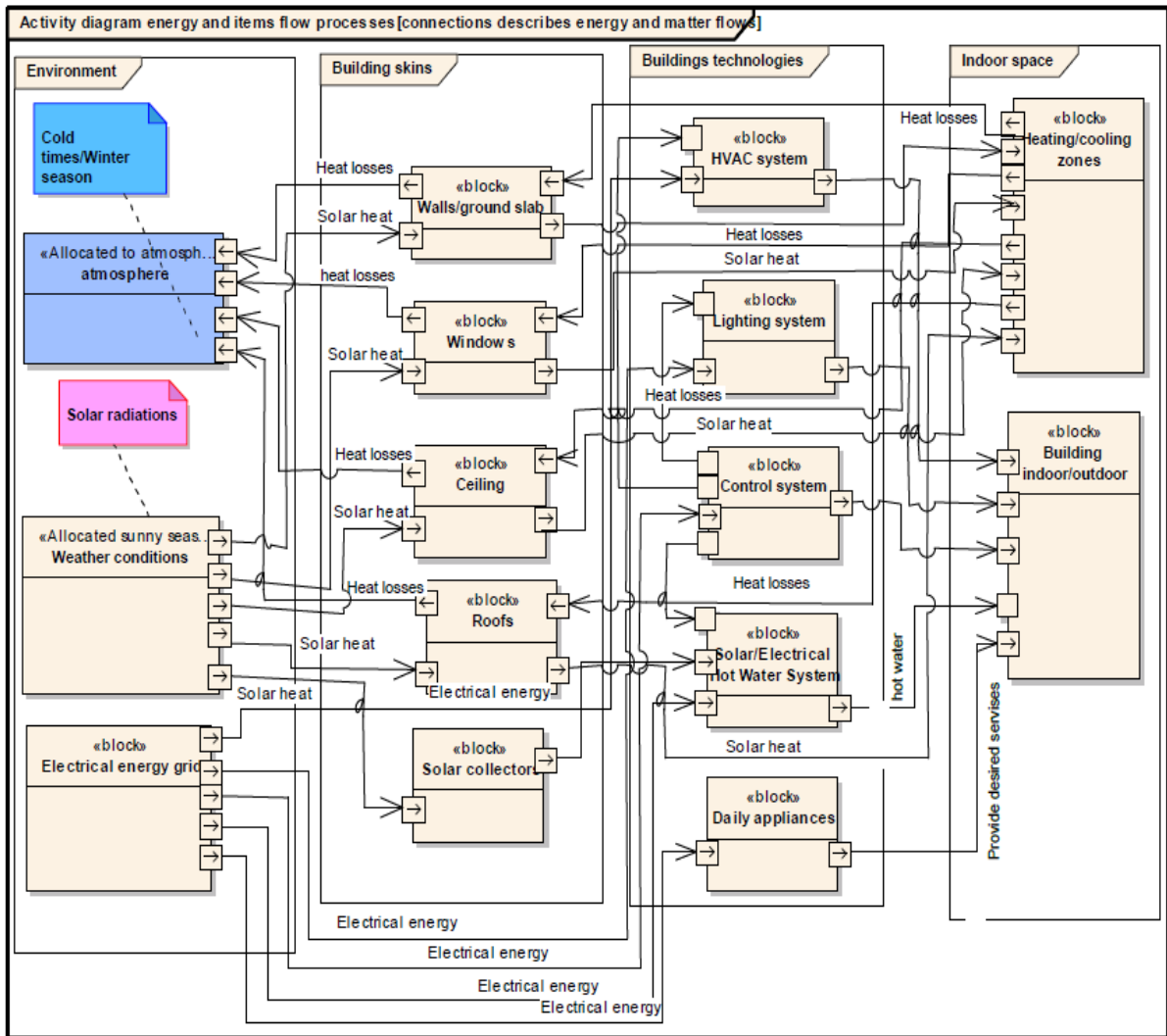
## REFERENCES

- America, I.E.S. of N. 1993. *Lighting Handbook: Reference & Application*. Illuminating Engineering Society of North America.
- CIBSE. (2000). *Building control system*. Woburn: CIBSE.
- commission, c. e. (2013). *www.consumerenergycenter.org*. Retrieved June 12, 2013, from [http://www.consumerenergycenter.org/home/heating\\_cooling/heating\\_cooling.html](http://www.consumerenergycenter.org/home/heating_cooling/heating_cooling.html)
- Company, L. C. (1999). *Engineering Cook book a handbook for the mechanical designer* (2nd edition ed.). Springfield.
- Dillon, B., & IBS. (2012, 07 31). *Sizing a guide to properly sizing residential equipment*. Retrieved 11 21, 2012, from [ibsadvisorsill.com](http://www.ibsadvisorsill.com): [http://www.ibsadvisorsllc.com/\\_library/residential\\_sizing](http://www.ibsadvisorsllc.com/_library/residential_sizing)
- E.Zambolan, & Padoven, A. (2009). Experimental daily energy performance of Flat Plat and Evacuated Tube Collector. *Energy Sustainability*.
- Engineers, C.I. of B.S. 2000. *Building Control Systems*. Routledge.
- Friedenthal, S., Moore, A. & Steiner, R. 2014. *A Practical Guide to SysML, Third Edition: The Systems Modeling Language*. 3 edition. Morgan Kaufmann.
- Grondzik, W. & Furst, R. 2000. HVAC components and systems. *Vital Signs Project*. [http://dualibra.com/wp-content/uploads/2011/06/hvac-big\\_opt.pdf](http://dualibra.com/wp-content/uploads/2011/06/hvac-big_opt.pdf) 31 October 2014.
- Guptan, G. W. (2003). *HVAC Controls Operation and maintenance*. Georgia: Fairmont.
- Holt, J., & Perry, S. (2008). *System Modeling Language for System Engineering*. London.
- Honeywell. (1997). *Engineering Manual of Automatic Control for Commercial Buildings HVAC*.
- Hordeski, M. F. (2001). *HVAC Control in the New Millenium*. Georgia: Fairmont Press.
- Janis, R. R., & Tao, W. K. (2005). *Mechanical and Electrical system in Buildings* (3th edition ed.). New jersey: Pearson.
- Jones, W. (2005). *Air Conditioning Engineering*. Elsevier.
- Kharagpur. (2008). *Refrigeration and Air Conditioning System*.
- Kreith, F., & Goswami, D. Y. (2007). *Hand bool of Energy Efficiency and Renewable Energy*. CRC Press.
- licht.wissen. (2012). *www.licht.de*. Retrieved march 06, 2013, from [http://www.licht.de/fileadmin/shop-downloads/lichtwissen01\\_artificial\\_light.pdf](http://www.licht.de/fileadmin/shop-downloads/lichtwissen01_artificial_light.pdf)
- Loren, C. C. (1999). *Engineering Cook Book*.
- Manyuchi, L. (2008). *Design Guidelined for Energy efficiency Buildings in Johannesburg*. Joburg: CSIR.
- Melki, S., & Hayek, M. (2009). Building Simulation Tools and their role in improvig Existing Building Design. *IEEE*. Lebanon: IEEE.

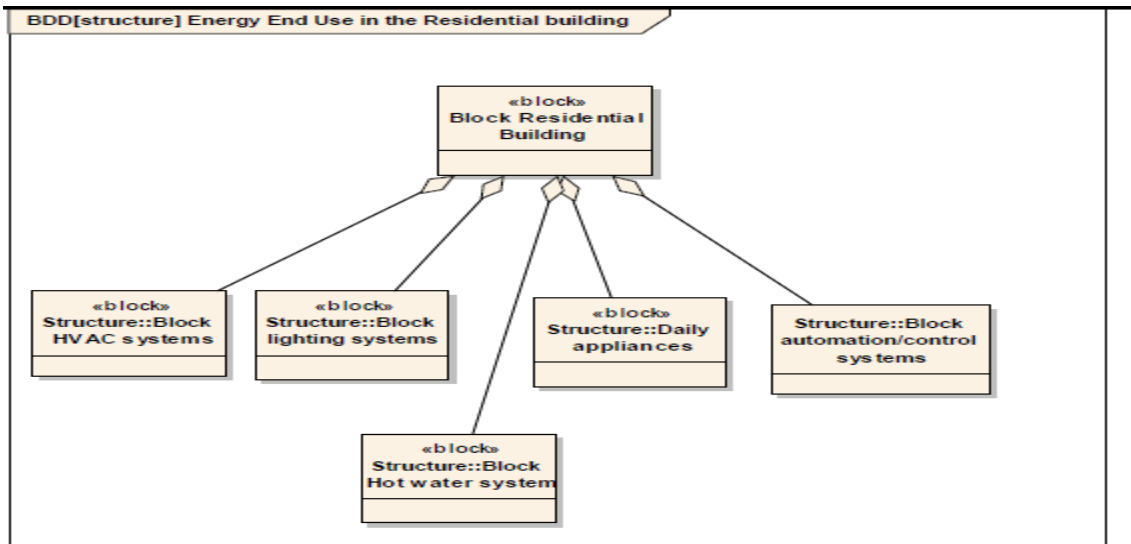
- Merz, H., Hansemann, T., & Hubner, C. (2009). *Building Automation communication system with EIB/KNX LON and BACnet*. berlin: Springer.
- Milford, R. (2009). *Greenhouse Gas Emission Baselines and Reduction Potentials from Buildings in South Africa*. Sustainable United Nations.
- Montgomery, R., & Dowell, R. M. (2009). *Fundamentals of HVAC systems*. bulington: Elsevier.
- Moore, R. A., & Paredis, C. (2009). Model-Based Optimization of a Hydraulic Backhoe using Multi-Attribute Utility Theory. *SAE World Congress*. atlanta: MBES.
- NREL. (2012, 03 8). *NREL*. Retrieved 06 22, 2013, from <http://www.nrel.gov/buildings/energy.analysis.com>
- NRL. (2012). *www.nrel.gov*. Retrieved march 08, 2012, from <http://www.nrel.gov/building/energy>
- Parise, G., & Martirano, L. (2009). Impact of Building Automation, control and building mamangement on energy performance of lighting system. Roma: IEEE.
- Porges, F. (2001). *HVAC Engineering's Hand Book* . Wolburn: Elsevier.
- Preez, K. D., & Vameulen, H. (2011). Development of an interactive, web, based energy usage applications for residential load. *Power engineering*. Berlin: IEEE.
- Quiston, F. C., Parker, J. D., Spitler, J. D., & J, W. (2005). *Heating Ventilatin Air Conditioning analysis and design* (6th edition ed.). Jonh wisley and son.
- Rajput, R. K. (2007). *Engineering Thermodynamics*. Doryaganz: LAXMI PuBLICATION.
- Rishel, J. B. (2006). *HVAC Pump Hand Book*. Elsevier.
- Ryer, A. (1998). *Light Measurement Handbook* . Newburyport: International light, Inc.
- Simpson, R. S. (2003). *Lighting control- Technology and Application*.
- Wang, Y. a. (2012). optimal control strategy for HVAC system in the building energy management . IEEE.
- Wenfa, H., & Wu, T. (2011). assessment in the resident building and case sutdy. (pp. 4860-4866). beijing: IEEE.
- Wissen, L. (2010). *www.licht.de*. Retrieved 4 12, 2012, from licht.wissen: <http://www.all-about-light.org/en/publication>
- Yang, Y., Zhu, Q., Maosoumy, & Sangiovanni, A. (2012). Development of Building Automation and control system. *IEEE*. California: IEEE.
- Zhan, H., Xia, X. ..., & Zhang, J. (2009). A residentail energy and power conservation system utilizing an Optimization model. *IEEE AFRICON* (pp. 22-25). Nairobi: IEEE.

# APPENDICES

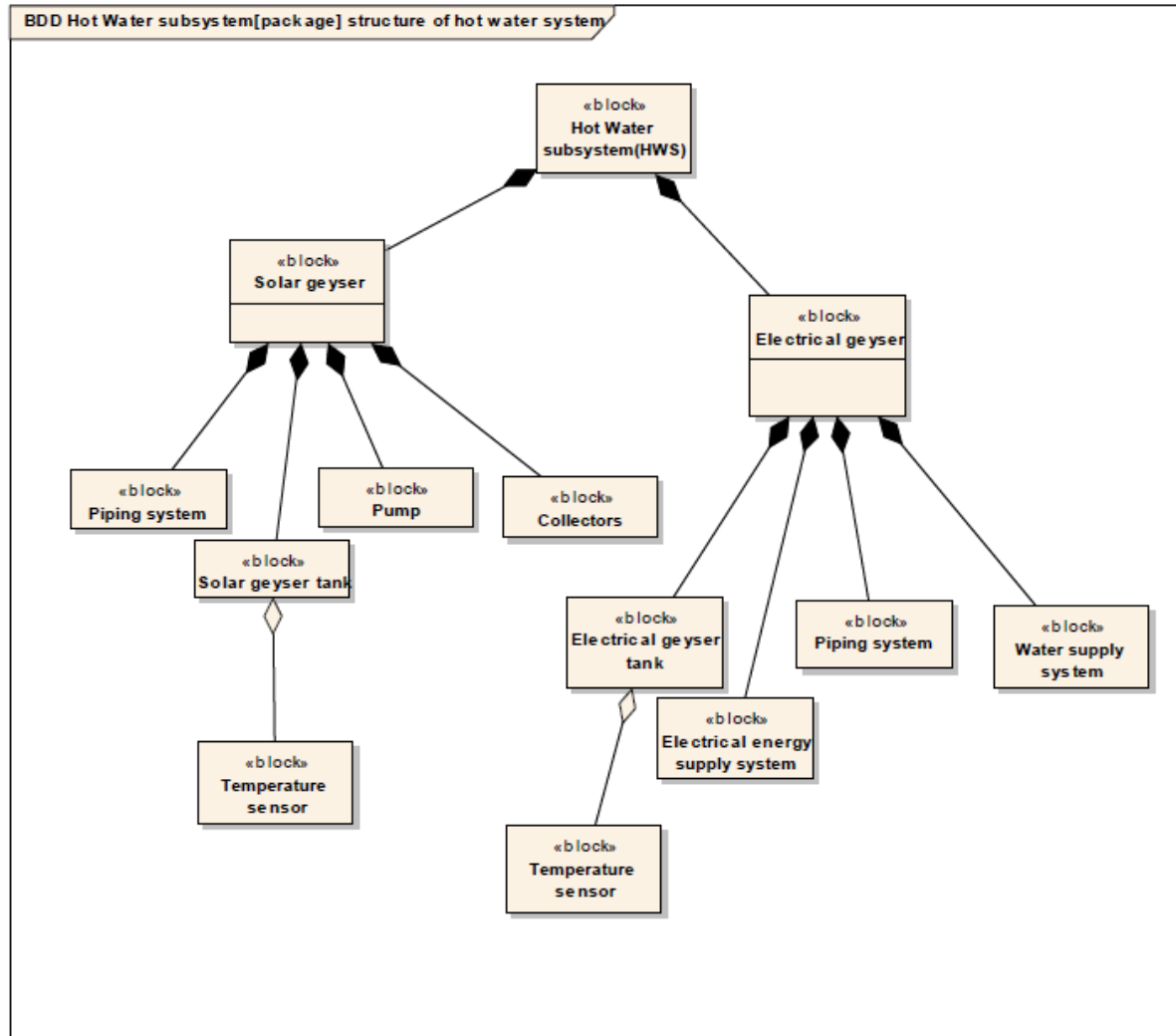
## APPENDIX A: SysML diagrams developed for building energy modeling



Activity diagram of energies and items flow processes

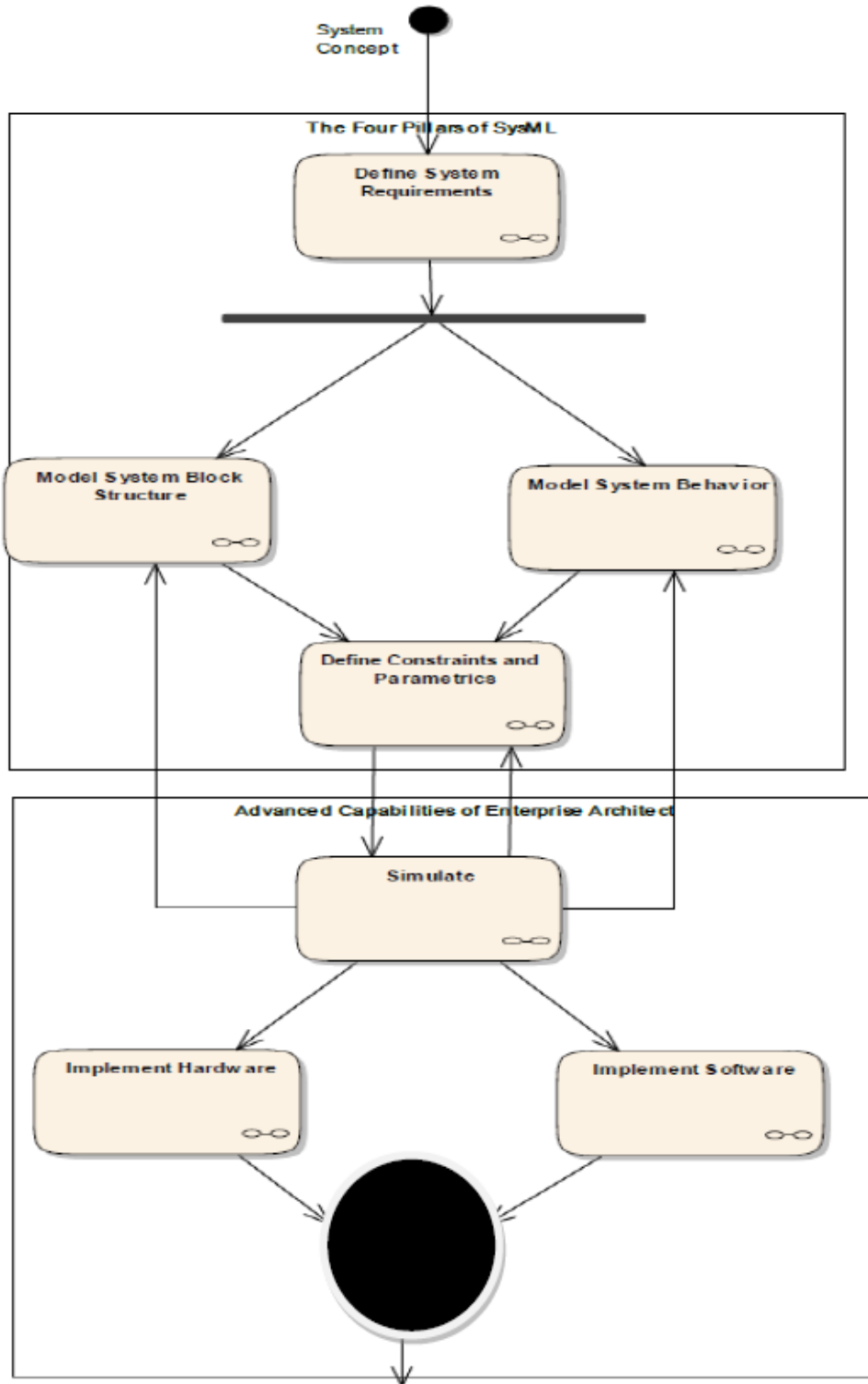


**Block Definition Diagram of Energy End Uses**



**Block Definition Diagram of structure of hot water system**

## APPENDIX B: Roadmap of System Modeling Language



Roadmap describing the four pillar of system modeling language



