

PENINSULA



TECHNIKON

FACULTY OF ENGINEERING

**A FEASIBILITY STUDY OF MANUFACTURING METHODS
FOR
LARGE SIZE MOULDS**

WANJUN LI

STUDENT NUMBER: 200206140

Submitted towards the Master of Technology Degree

(Mechanical Engineering)

2004

Supervisor: H. C. Bowles, M. Sc. Eng. Mech. (UCT)

**Co-Supervisor: W. P. Mitchell, B. Eng. Mech. (Pret), Dip. Datametrics (UNISA),
Pr. Eng, GCC (Factories)**

ABSTRACT

Most very large moulds are manufactured in Europe, especially in Germany and Italy. The main reason being that South Africa does not have enough very large size CNC machines on which these could be machined. A large size mould half can be split into two or more smaller parts for machining purposes and then reassembled later. In this way many large size moulds, especially rotational moulds can be manufactured on medium size CNC machines. Since the large component has been split into small parts, these can be distributed to different subcontractors to machine simultaneously, and thereby reducing the total manufacturing lead-time.

The project then uses three case studies to advance the proposed concept for mould manufacture. A small size rotational mould for a model drum is manufactured to confirm that Pentech had both the infrastructure and required skill to make a rotational mould of any sort. Then a medium size rotational mould of a steering wheel is manufactured. This case study is the key and longest stage in this project; it consists of the full process of mould subdivision followed by full mould manufacture, some subcontracting of parts and lastly full product testing. Finally, a part of a large size mould was manufactured for purpose of investigating all aspects around the subcontracting of mould parts.

In the first case study the clamping strategy used through out as an integral part of the subdivision strategy is proven. The second case study using the medium size rotational mould successfully demonstrates the subdivision concept, along with its material savings. This second case study also introduces the idea of including CNC lathe parts. Lastly, the third case study using a large size rotational mould proves the contractibility of the mould segments using NC files, despite certain industry leaders believing that machine shops would not be interested in accepting work on the basis of NC files.

ACKNOWLEDGEMENTS

The author is grateful to have been able to conduct a researching project in the CAD/CAM mould making industry, an industry in line with previous industrial experience and future career aspirations.

The author would like to express his gratitude to the following people:

Mr. Hellmut C. Bowles for his financial help at the beginning of the project, the original idea behind the project and for his full support through the full duration of this project.

Mr. Wayne Mitchell for his assistance with the English language in both spoken and written forms and for extensive technical CNC machining assistance.

Mr. Gamiel Saal for his EdgeCAM software training, tips and assistance, as well as his assistance with several tricky CNC machining problems.

Mr Keith Hector of the Bellville Technical College for his free usage of the CNC lathe.

Mr. Erich Essmann of Speedwell Engineering for the free manual polishing work done on one of project moulds and also the advice concerning manual polishing of mould cavities.

A special thanks for Mr. Gary Lategan, director of the Atlas Plastics Company, for the product ideas and free use of his factory facility to do the rotational mould testing. Mr. Lategan was instrumental in this work and initiated the concept of using this approach for the rotational moulding industry.

Thanks also to Prof. Graeme Oliver for his assistance with a whole range of academic matters.

TABLE OF CONTENTS

Chapter 1.	Introduction	1
Chapter 2.	Rotational moulding.....	9
Chapter 3.	Industrial software used	18
Chapter 4.	Optimum subdivision of mould halves	21
Chapter 5.	Small size rotational mould.....	27
Chapter 6.	Surface finish experiment.....	45
Chapter 7.	Medium size rotational mould.....	51
Chapter 8	Large size rotational mould.....	84
Chapter 9.	Conclusions	99
References	101
Appendices	A1

LIST OF FIGURES

Figure 1.1	Subdivided mould halves.....	2
Figure 1.2	Project Flow Diagram	5
Figure 1.3	Steering wheel mould half.....	7
Figure 1.4	One-piece billet to machine the mould half of figure 1.3	7
Figure 1.5	Two-piece billet to machine the mould half of figure 1.3.....	7
Figure 2.1	Schematic of the rotational moulding process	9
Figure 2.2	Rotational moulds mounted in a standard type rotational moulding machine.....	10
Figure 2.3	'Rock-'n-Roll' type rotational moulding machine with a single mould .	10
Figure 2.4.	Traffic sign product.....	13
Figure 2.5.	Various small size rotational mouldings.....	15
Figure 2.6.	Large size rotational moulded oil recovery bank	15
Figure 3.1.	An exploded CAD assembly model made up of separate CAD part models all created in SolidWorks	18
Figure 3.2.	EdgeCAM milling simulation, one view.....	19
Figure 3.3.	EdgeCAM milling simulation, multi views	20
Figure 4.1.	Rotational moulded floor sweeper frame part.....	21
Figure 4.2.	Rotational moulded used coolant reservoir part.....	22
Figure 4.3.	The water tank product.....	23
Figure 4.4.	Water tank mould top half.....	23
Figure 4.5.	Water tank mould lower half.....	24
Figure 4.6.	Mould segments of the mould top half.....	25
Figure 4.7.	Mould segments of the mould lower half.....	25
Figure 4.8.	Choosing a split line.....	26
Figure 5.1.	CAD drawn rotational mould parts inserted into available billet.....	27
Figure 5.2.	Top view of CAD designed product	28
Figure 5.3.	Bottom view of CAD designed product.....	28
Figure 5.4.	Aluminium workpiece.....	29
Figure 5.5.	Steel workpiece clamping frame	30
Figure 5.6.	Workpiece mounted on the clamping frame	30
Figure 5.7.	Hole arrangement on clamping frame.....	32
Figure 5.8.	Hole positions on workpiece.....	32
Figure 5.9.	Machining steps on mould product side.....	33
Figure 5.10.	Product side of mould parts completed before flipping workpiece.....	34
Figure 5.11.	Close-up of the drum side cavity.....	34
Figure 5.12.	Mould reverse side in process on CNC milling machine.....	36
Figure 5.13.	Mould reverse side in process on CNC milling machine.....	37
Figure 5.14.	Mould part separation slots	38
Figure 5.15.	Finished rotational mould parts, product side	39
Figure 5.16.	Finished rotational mould parts, reverse side.....	39
Figure 5.17.	Assembled mould to be tested.....	40
Figure 5.18.	The processing of the moulding	41
Figure 5.19.	Product and mould during demoulding	41
Figure 5.20.	Final product of model size 220 l drum	42
Figure 5.21.	Mould part separation slots	43
Figure 6.1.	CAD model of the test part.....	46
Figure 6.2.	EdgeCAM toolpath generation.....	48
Figure 6.3.	Cutting simulation in EdgeCAM.....	48

Figure 6.4.	The five machined test parts.....	50
Figure 7.1.	Workpiece for mould topside.....	51
Figure 7.2.	Mild Steel clamping frame.....	52
Figure 7.3.	Workpiece bolted to clamping frame.....	52
Figure 7.4.	Steering wheel, front-side view in SolidWorks.....	53
Figure 7.5.	Steering wheel, reverse side view in SolidWorks.....	54
Figure 7.6.	Rotational mould for steering wheel, exploded view.....	55
Figure 7.7.	Rotational mould for steering wheel, assembled view.....	55
Figure 7.8.	CAD model of smaller insert part.....	57
Figure 7.9.	CAD model of bigger insert part, product side.....	59
Figure 7.10.	CAD model of bigger insert part, reverse side.....	59
Figure 7.11.	EdgeCAM programming of first turning step.....	60
Figure 7.12.	EdgeCAM programming of second turning step.....	61
Figure 7.13.	EdgeCAM programming of third turning step.....	62
Figure 7.14.	The bigger insert part after completion of CNC turning.....	63
Figure 7.15.	Bigger insert part for CNC milling.....	64
Figure 7.16.	CNC milling toolpaths for the 3 fillets of bigger insert part.....	64
Figure 7.17.	Product side cutting flow with required cutter types.....	65
Figure 7.18.	Toolpath programming for the top mould plate, product side.....	65
Figure 7.19.	Simulation of the reverse side roughing of the top mould plate.....	66
Figure 7.20.	Toolpath programming of cavity of the lower plate, product side.....	69
Figure 7.21.	Lead-in and lead-out test part CAD model.....	70
Figure 7.22.	Horizontal type lead-in and lead-out EdgeCAM settings.....	71
Figure 7.23.	Horizontal type lead-in and lead-out result.....	72
Figure 7.24.	Tangential to surface lead-in and lead-out EdgeCAM settings.....	73
Figure 7.25.	Cutting marks at tangential to surface lead-in and lead-out position.....	74
Figure 7.26.	Comparison of cutting marks for the two methods.....	75
Figure 7.27.	Hole toolpath programming of reverse-side of the lower plate.....	76
Figure 7.28.	Simulation of the reverse side of the lower plate.....	77
Figure 7.29.	Completed top mould half, product side.....	79
Figure 7.30.	Completed top mould half, reverse side.....	79
Figure 7.31.	Completed lower mould half, product side.....	80
Figure 7.32.	Completed lower mould half, reverse side.....	80
Figure 7.33.	Mould assembled in process machine mounting frame.....	81
Figure 7.34.	Processing of moulding in the rotational machine.....	81
Figure 7.35.	Demoulding of first product.....	82
Figure 7.36.	Close-up of first product.....	82
Figure 8.1.	Flow diagram of workpieces to be subcontracted.....	84
Figure 8.2.	CAD model of the reverse side of mould part.....	85
Figure 8.3.	CAD model of the product side of mould part.....	85
Figure 8.4.	Toolpath programming reverse side of mould part.....	86
Figure 8.5.	Reverse side of mould part after machining.....	87
Figure 8.6.	Toolpath programming product side of mould part.....	88
Figure 8.7.	Product side of the part after being machined.....	89
Figure 8.8.	CNC milling machine at ISP Company.....	92
Figure 8.9.	Subcontractor's quotation from the ISP Company.....	95
Figure 8.10.	Quotation from the C.F.W Industrial Company.....	97
Figure A1.	Letter from the industrial partner company on their assessment of the medium size steering wheel mould produced.....	A1
Figure C1.	Pentech's Eumach CNC milling machine.....	C1

LIST OF TABLES

Table 6.1	The common parameters for all 5 of the ball nose cutters	46
Table 6.2	The feedrate and spindle speed of these five brand cutters.....	47
Table 6.3	Comparison of simulation time and actual cutting time for this experiment	49
Table 7.1	Simulation time versus Actual cutting time for the top part	67
Table 7.2	Simulation time versus actual cutting time for this part.....	77
Table 7.3	Breakdown of material utilized with and without mould segmentation approach	83
Table 8.1	NC files, which can be used for the subcontract for the reverse side.....	87
Table 8.2	NC files, which can be used for subcontracting of the product side.....	89
Table B-1:	Seco material group classifications	B1
Table B-2:	Cutter parameters specifically for aluminium	B2
Table C-1:	Comparison between Mitsubishi and Fanuc control system	C2
Table C-2:	Specification of Pentench's CNC milling machine.....	C3

GLOSSARY

CNC	Computer Numeric Control which refers to any machine tool which is controlled by a computer program defining move and process commands as well as the co-ordinates to be able to complete these commands.
NC	Numeric Control very similar to CNC and for purposes of this work considered to be the same. The subtle differences are only really of significance to the machine tool supply industry.
CAD	Computer Aided Design (or Draughting)
3D	3 dimensional i.e. not flat. Here refers mostly to a computer model of an object with 3 dimensions as apposed to a 2 dimensional drawing that will be printed to be used on a factory floor.
CAM	Computer Aided Manufacture in a broader sense can mean all computer assistance used in manufacture which is a very wide range of software types and applications. This work uses the more narrow common usage meaning a type of software that can read a 3D CAD model and then be used to generate cutting toolpaths for various machine tools such as CNC milling machines, CNC lathes, wire cutting machines etc.
CAD / CAM	As CAD and CAM are used largely together so this term is seen joining the two.
NC file	A file which contains G and M-code type machine commands as well as many X, Y, and Z coordinates. This type of file generally contains the cutting program to cut a part on a CNC machine tool. These files are usually machine specific, especially the header and tail of the file (the first portion in the beginning of the file and also the last portion).
IGES file	Initial Graphics Exchange Specification file format. This is one of the more general file formats used when importing and exporting CAD models between both CAD and CAM software packages.

CHAPTER 1 INTRODUCTION

The purpose of this research is to investigate the feasibility of manufacturing large size moulds, especially rotational moulds, using a layered object manufacturing approach to subdivide the mould into several parts and reassemble after machining. This approach has the advantage that smaller CNC machines can be used and material waste can be reduced. Every year in South Africa's mould making and tool-making industry many large size moulds, including rotational moulds, plastic injection moulds and plastic blow moulds are being manufactured outside the country because of cost and resource issues. Further more, if at least some of the large size moulds can be manufactured in this layered or segmented approach then smaller parts can be subcontracted to several smaller businesses with medium size CNC machines to in the end create large and complete moulds. There are two benefits of subcontracting: firstly, the product manufacturing lead-time can be shortened and secondly, it can provide more employment opportunities to small business in South Africa.

Atlas Plastics, the project partner, is one such company, which sources all of its large size rotational moulds from manufactures in Italy. Being a developing country, South Africa has many conventional manual machines at its mould maker and toolmaker workshops, a few medium size CNC machines and an increasing number of small size CNC machines. The question of how to improve the manufacturing capacity and ultimately utilize the limited medium size CNC machines for mould manufacture is becoming critically important in South Africa. In this project, CAD/CAM software is being used to create 3D solid models and generate proposed split moulds. These are then manufactured using a medium size CNC milling machine in Mechanical Engineer Department at the Peninsula Technikon to demonstrate the concept.

1.1. PROBLEM STATEMENT

A large size mould half can be split into 2 or more smaller parts and then, bolts and nuts are used to assemble them at the return flanges, as indicated in the Figure 1. In this way many large size moulds, especially rotational moulds can be manufactured on medium size CNC machines. Since the large component has been split into small parts, these can be distributed to different subcontractors to machine simultaneously, and thereby reducing the total manufacturing lead-time.

The basic concepts of this research can be illustrated by using the following sketches.

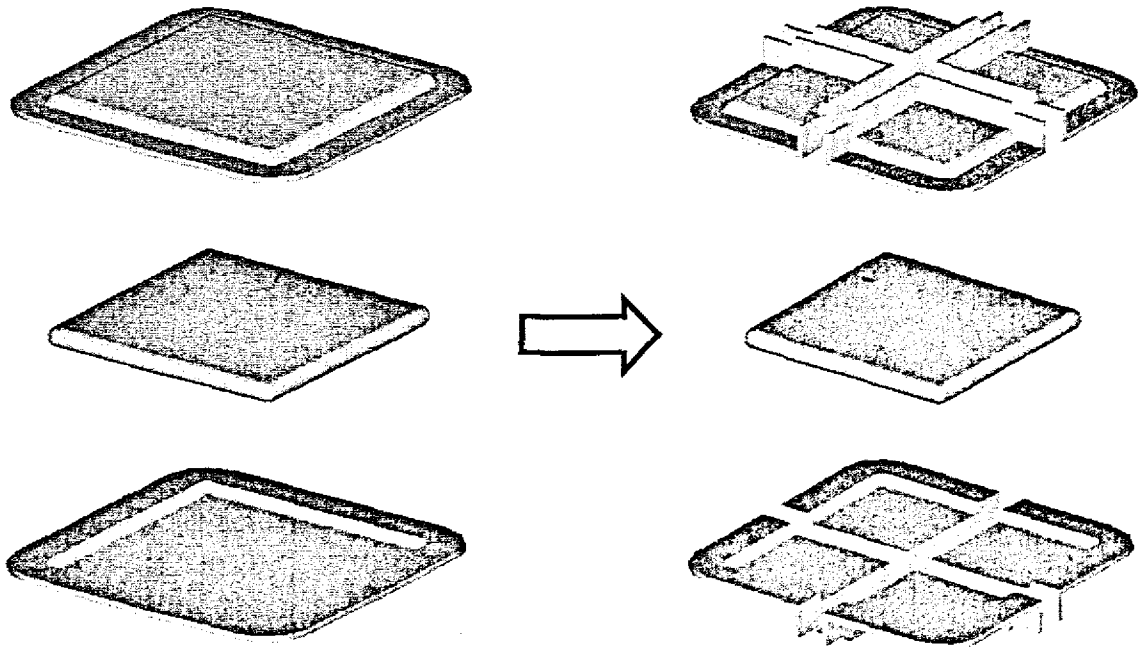

Figure 1.1. Subdivided mould halves. [24]

1.2. EXPECTED CHALLENGES:

Although one mould can be divided into several machinable parts or segments, this mould making strategy cannot work for all moulds, especially not for injection moulding where the cavity pressures are high. A number of challenges are anticipated concerning the design of the split mould, clamping, and manufacturing when using a medium size CNC machine.

- a) How to clamp workpiece into the CNC machine worktable. Although the large size mould has been split to small pieces, some small pieces are still large and make clamping at the worktable difficult. Many of these small mould pieces will need to be clamped from below only. Thus some innovation will be required in order to achieve the envisaged goals.
- b) Identifying the best split line on mould halves, allowing for further subdivision and deciding on the final number of pieces for a large size mould in order to obtain easy manufacturing.

- c) In order to achieve short manufacturing lead times it is inevitable that work will have to be subcontracted for the various split mould parts. Some management will be required to allocate work appropriately according to workshop capabilities and ensure satisfactory deliveries.
- d) Access to large size CNC machines or high speed milling machines in South Africa is limited, so one of the key purposes of this project is aimed at distributing the split mould parts to several machine shops, whereby all the CNC codes should be generated by one source in order to control the manufacture time and costs. By taking advantage of the fact that each mould would typically consist of 6 to 12 split mould parts, it will be faster to utilize several medium size CNC machines to finish the cutting job than using a large size or high speed CNC machine. So one of the difficulties that need to be overcome is developing a “team South Africa” approach within the manufacturing sector, rather than the current “each one for themselves” attitude.
- e) Establishing the software and machine parameters so that the actual cutting time will be exactly same as the simulation time in the software.
- f) There are some disadvantages of using this method to manufacture large size moulds in that the mould design will become more complicated and designers will have to consider the geometric details and the possibility of splitting these. There will be issues associated with determining the best split lines to assure manufacturing precision as well as the best ways to manufacture the mould.
- g) Assembly problem, e.g. gaps, tolerance, may occur when assembling the components of each mould half.

1.3. THE DELIMITATIONS

Only rotational moulds are being considered in this research. There are many different kinds of moulds in the moulding industry including; plastic injecting mould, rotational mould, and plastic blow mould, etc. In plastic injection moulding, the melted plastic material is injected into the mould cavity by high injection pressure. Because of the high injection pressure there is some flashings on the product's outer surfaces at the mould part lines. The higher the injection pressure inside the mould, the more rough the flashings at the product's surfaces. Sometimes the flashing is unacceptable and regarded as a critical defect on the products. Also the cost to make a large size plastic injection mould is higher than making a rotational mould because it requires an expensive large size steel mould base and large size injection machines to make products. Therefore, in this research only large size rotational moulds are being considered and investigated.

This project requires minimum lead times and thus only insert tooling will be used for rough cutting. The faster feed and speed times of this type cutter make it an obvious choice. Only insert tooling from the Seco Company, Sweden, will be used because of our large collection of Seco tool holders and the expert technical advice we enjoy free of charge from the local agent.

All moulds require excellent surface finishes. Experiments on which cutter type provides the best finish will need to be done. Early indications are that Tungsten Carbide may present the best answer. There is however a new range of X-Power cutters from ToolQuip and an engraving range from Jabro, Holland, which need to be investigated.

Aluminium is used in this project for manufacturing large size rotational moulds because of its good heat transfer properties required by the rotational moulds. It is also beneficial to the project due to its ease of machining.

Usually a complicated large size mould has many manufacturing processes including CNC milling, CNC turning, EDM Wire, Grinding, etc. Only CNC milling and CNC turning machines will be considered in this project due to availability of infrastructures (Pentech CNC milling and Bellville Technical college CNC turning machine).

1.4. RESEARCH ASSUMPTIONS.

In rotational moulding, plastic powder is poured into the mould cavity, the mould is then heated and rotated, plastic powder flows within the mould and attaches itself to the mould surface where it melts and subsequently solidifies on cooling. Since there is no high injection pressure inside the cavity, it is assumed that the split lines of the rotational mould on the surfaces of the products do not have a significant impact on the appearance and product function. Hence a split line on the product surfaces will be considered acceptable by the customers.

For this research purpose only, if a CNC milling machine has the capacity of accommodating a workpiece of or greater than 1500mm×1000mm×600mm; it is defined as a large size CNC machine.

The worktable size of CNC milling machine at Mechanical Department of Peninsula Technikon is 1000mm×500mm×500mm. It is called a medium size CNC machine. The parts, which can be clamped at this machine worktable, are called smaller parts.

1.5. RESEARCH OBJECTIVES

Rotational mould manufacturing companies can ultimately utilize local medium size CNC machines to manufacture large size rotational mould and increase South Africa's capability to compete for this work. The labour costs and manufacture costs are cheaper in SA than other countries in Europe because of the weak Rand exchange rate to dollar. The Department of Mechanical Engineering at Pentech together with its rotational moulding partner, CNC machine shop subcontractors, will have demonstrated the capability to produce large size rotational moulds.

Reducing rotational mould manufacturing lead times through subcontracting small parts to different subcontractors at the same time. If a large size mould has been split to small parts using computer software, then we can export these parts files to some neutral file forms, such as IGES, STEP. Our subcontractors can import these neutral

files into their different computer software. In this way, they can start the manufacturing work using their own software and their own experiences. Hopefully we can establish longstanding co-operation relationships with reliable contractors.

Potential problems exist using different software for CAD / CAM operations. Experience suggests that compatibility issues can be problematic. A method to overcome these issues will have to be devised.

Reduced long term cost, since it is cheaper and easier to maintain or replace the parts of a divided mould half than maintain / replace original one-piece mould half. Mistakes during manufacturing therefore only affect that part and do not require the remanufacture of the entire mould.

1.6. RESEARCH METHODOLOGY

The author will become sufficiently proficient with the necessary software, namely SolidWorks as the CAD package and EdgeCAM, to develop and manufacture three different rotational moulds, namely a small, medium and large size rotational mould.

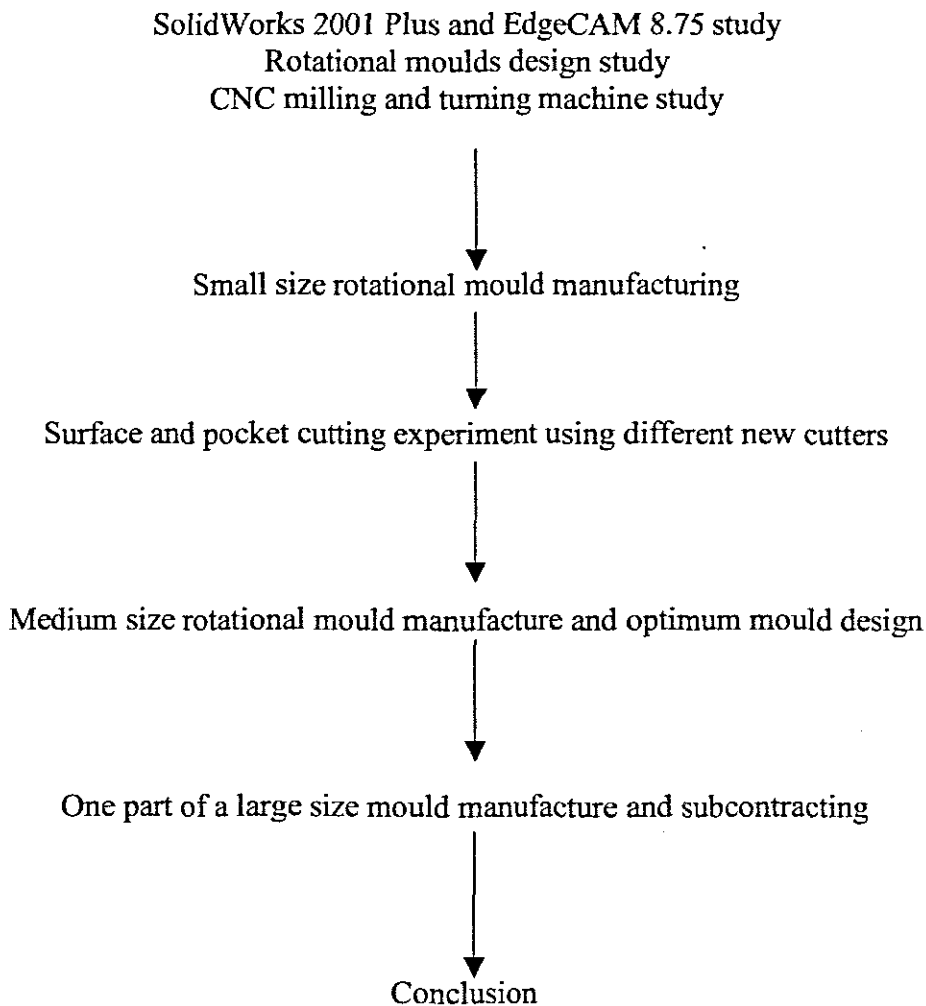

Figure 1.2. Project Flow Diagram

The Software study in this project is focused on SolidWorks 2001 Plus and EdgeCAM versions 5.75, 7.5 and 8.75. The software training started in the second semester of 2002 at Peninsula Technikon with short training courses by the representatives of the software suppliers. SolidWorks is the CAD software that will be used for creating 3D solid models and editing those supplied by the industrial partner. EdgeCAM is the CAM software that will be used for creating the toolpaths needed for the cutting operations and then from the toolpaths the NC part programs to actually do the cutting on the CNC machines.

CNC lathe programming and machine operation training has been done at Bellville Technical College during the second semester, 2003, in order to manufacture the turned parts for the large size mould.

The purpose of the small size rotational mould manufacture is to prove and qualify the rotational mould making ability on Pentech CNC milling machine. This mould will have no part subdivision and all parts will be small enough to fit comfortably on the table of Pentech CNC milling machine. This small size mould has two added objectives. Firstly, the proposed frame type work holding method to be used on the larger mould parts is to be tested. Secondly, the concept of making more than one part from one aluminium billet and then slitting then on the holding frame, as a last step will be tested. Atlas Plastics provided the CAD 3D model and aluminium material for the manufacture of the rotational mould. This has been completed successfully in the first semester, 2003.

From the process of manufacturing the first small size rotational mould the importance of the surface finish quality was highlighted and hence an experiment was designed to establish the best cutter types and cutting parameters to use to ensure a high quality surface finish.

The medium size rotational mould was used to develop the optimum mould half subdivision strategy. Typically in this mould i.e. the steering wheel mould, there is a central boss that stands proud of the rest of the mould half making it an ideal feature to be converted into a separate part. Here an insert type part is made. This gives a large material waste and machining time saving.

The following figures show this principle:

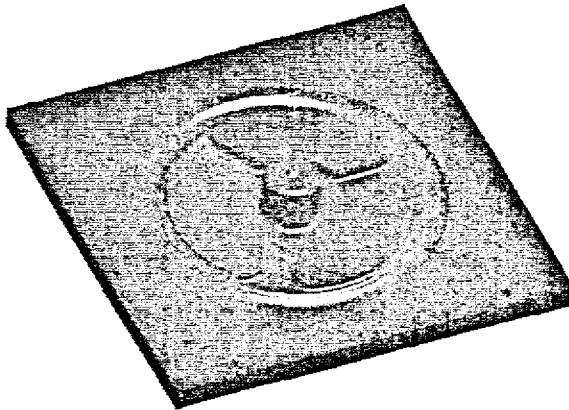

Figure 1.3 Steering wheel mould half

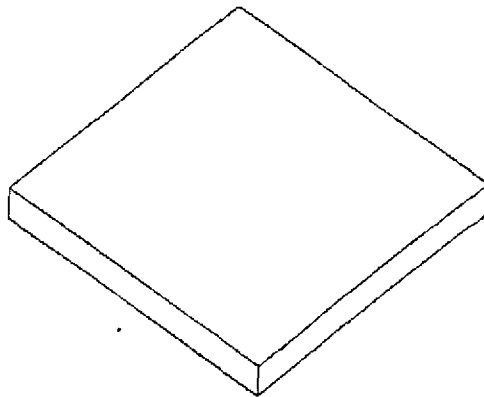

Figure 1.4 One-piece billet to machine the mould half of figure 1.3

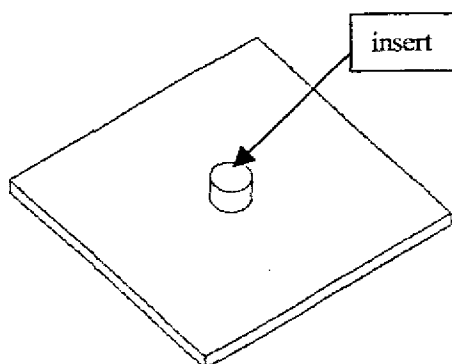

Figure 1.5 Two-piece billet to machine the mould half of figure 1.3

Notice how the thinner plate and round insert of figure 1.5 make up much less material than the single thicker plate of figure 1.4. Both can be used to machine the same mould half if figure 1.3.

One set of medium size moulds is to be manufactured at Peninsula Technikon during semester 1, 2004. The rotational mould includes some split mould parts, which will be manufactured using a CNC lathe. Atlas Plastics will provide the computer-designed 3D product model. The purposes of the mould is to demonstrate the project strategy on a small scale with relatively simple mould half subdivision, to obtain the actual manufacturing time in order to compare with the simulation time, to sharpen the top surfaces corner on flanges, to test the assembling methods after the split mould parts have been finished, to check if the finished surfaces can approach the required standard quality, to improve the roughing lead times especially at the reverse side of split mould parts.

One eighth of a large size mould is to be manufactured at Peninsula Technikon during the first semester, 2004. Atlas Plastics will provide the computer-designed 3D product model and mould drawing. The purposes of the mould include to demonstrate the project strategy on a full scale, to obtain the knowledge of how to manufacturing large size mould on the medium size CNC machine, to test the whole subcontracts cycle, to compare and analysis all the other three subcontract machine shop's manufacturing data with the one made by Pentech, to get some CNC milling expertise from other machine shops.

The time span for this project should be from July 2002 to December 2004, namely two and half years.

1.7. SCOPE OF THESIS

Because of the low internal pressures this study has been limited to the rotational moulding industry. This is a very versatile moulding method that allows very large size products to be formed, which would not be possible using other processes.

Next consider the CAD/CAM software used by mould maker in designing and machining of moulds. In this project will use SolidWorks 2001 Plus and EdgeCAM 8.75. The idea of mould half subdivision is put forward with an example.

The project then uses three case studies to advance the proposed concept for mould manufacture. A small size rotational mould for a model drum is manufactured to confirm that Pentech had both the infrastructure and required skill to make a rotational mould of any sort. Then a medium size rotational mould of a steering wheel is manufactured. This case study is the key and longest stage in this project; it consists of the full process of mould subdivision followed by full mould manufacture, some subcontracting of parts and lastly full product testing. Finally, a part of a large size mould was manufactured for purpose of investigating all aspects around the subcontracting of mould parts. Along the way a few experiments are carried out to assist in solving problems experienced in the case studies. These is a surface finish experiment and a lead-in and lead-out experiment.

CHAPTER 2 ROTATIONAL MOULDING

Rotational moulding is one of the most versatile moulding methods in the plastics industry. It allows very large size products to be formed, which would not be possible using other processes. Rotational moulding is a three-station process. An enclosed mould rotates as it is moved from a loading, heating, and cooling station. The principle for this moulding is as follows:

- 1) Plastic is introduced to the rotational mould in powder form up to the mass required for the required product.
- 2) The mould is then closed and passed into an oven chamber; the mould is then heated externally to a temperature typically between 220°C and 400°C and is rotated around both vertical and horizontal axes. As the mould rotates, the inner surface passes through the mass of powder at the bottom of the mould. As the mould heats up, the powder begins to melt and adhere to the inner surface of the mould. The mould continues to rotate in the presence of the heat and more plastic melts and builds up to produce an even layer over the surface of the mould.
- 3) The mould is then withdrawn from the oven and moved into a cooling chamber where cool air is directed at the mould and in some cases water are used to cool the mould. When the plastic inside the mould has solidified, the mould can be removed from the cooling chamber and the plastic component is then demoulded from the mould. The rotational speed, heating and cooling times are all controlled throughout the process.

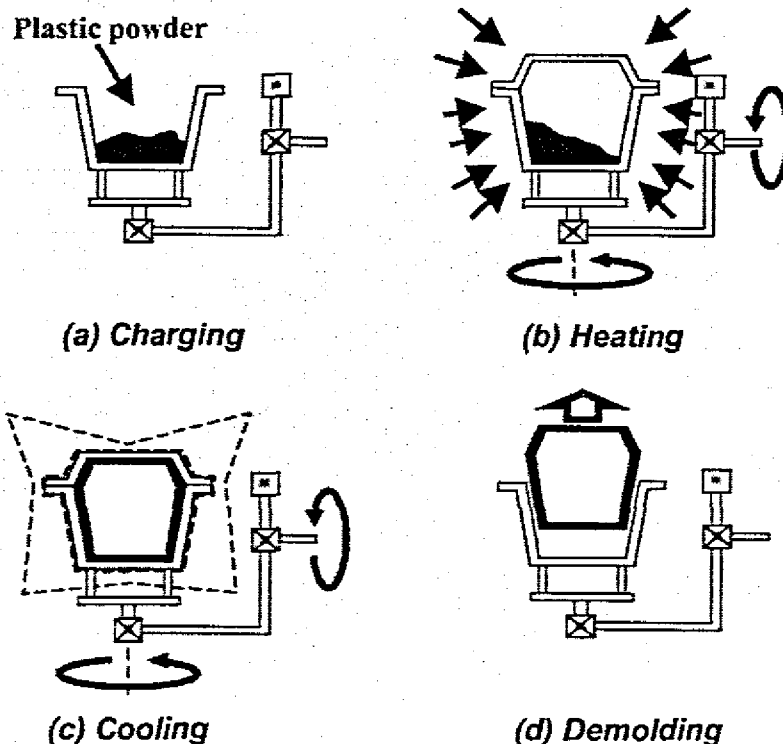

Figure 2.1 Schematic of the rotational moulding process. [1]

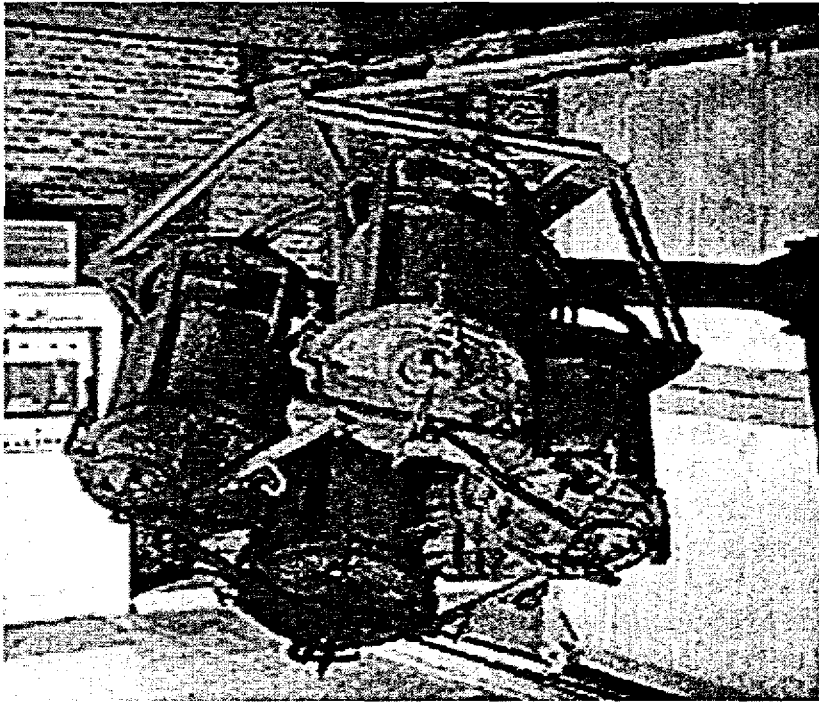

Figure 2.2. Rotational moulds mounted in a standard type rotational moulding machine
(Compliments of Atlas Plastics)

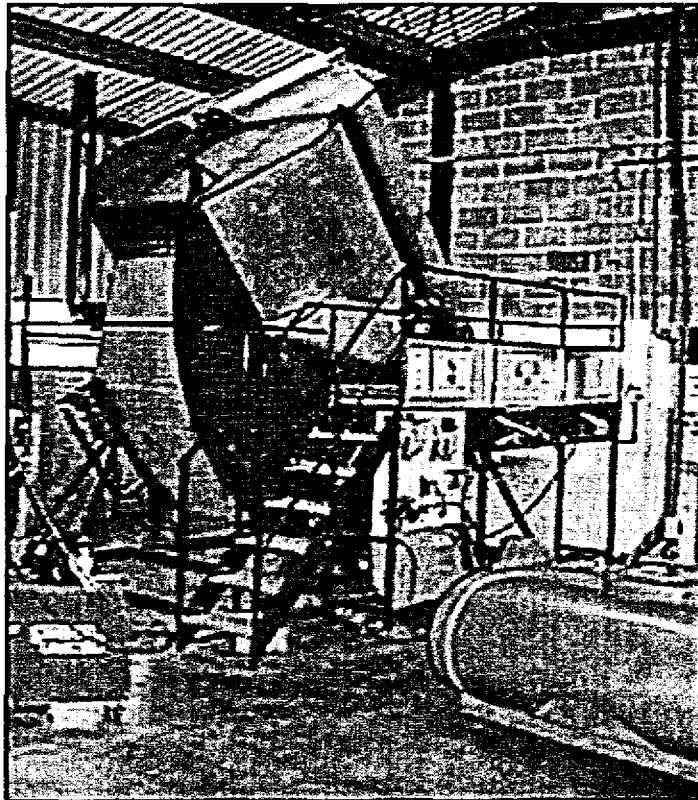

Figure 2.3. 'Rock-'n-Roll' type rotational moulding machine with a single mould
(Compliments of Atlas Plastics)

Rotational moulding is a slow and low-pressure process. Plastic parts that are enclosed, such as children toys, barrels, surf boards, tanks, and watering pitchers, are rotationally moulded. Moulds can be easily made from aluminium sheet or castings. Moulds are thin walled for good heat transfer. The wall thickness of the part is controlled by the amount of material placed in the mould. The interior surfaces of all rotationally moulded parts are smooth with a high gloss finish. The exterior appearance of the part duplicates the mould surface finish. Generally, these products have thick walls and are heavy. Large 40,000-gallon acid storage tanks have been successfully moulded with this process. Rotational moulding easily and economically produces liquid storage tanks with complex shapes.

The manufacturing lead times can vary from five minutes to one hour depending on the material used, the wall thickness and the equipment being used.

Previous research results have shown that the lead-time varies when using different machines and tools. "A machine tool selection is an important decision-making process for many manufacturing companies. Improperly selected machines can negatively affect the overall performance of a production system. The speed, quality and cost of manufacturing strongly depend on the type of the machine tool used." [2]

"We present a detailed theoretical heat transfer model for the entire rotational moulding process (including heating and cooling stages) and identify the key dimensionless groups affecting the process cycle time. This theoretical model is employed to generate numerical results that are in very good agreement with the experimental data available in the literature. The effects of variations in the dimensionless groups on the cycle time are evaluated. In addition, part shrinkage has been incorporated in the models, and its effect on the process cycle time has been studied extensively." [17]

The product size of a rotational mould can be as big as a street removable bookstall. Comparing with the injection mould, the products of rotational moulds are bigger and cheaper because it is impractical to have such a huge injection machine to produce such big a product. On this basis it provides the opportunity for the feasibility study to split large size rotational mould halves into assemblies of smaller parts.

Rotational moulding is a low pressure, high temperature manufacturing method for producing hollow one-piece plastic parts. The moulding process dates back hundreds of years to the Swiss use of the method to make hollow chocolate eggs. The technology involves aspects ranging from mould design to mould heating and cooling, and demoulding methods. Not all materials are suitable for the process - resin and additive selection are critical.

Rotational moulding is a very competitive alternative to blow moulding, thermoforming and injection moulding for the manufacture of hollow plastic parts. It offers designers the chance to produce stress-free articles, with uniform wall thickness and complex shapes. Typical moulded parts include bulk containers, tanks, canoes, toys, medical equipment, automotive parts and ducts.

There are many advantages associated with rotational moulding. Firstly, the moulds are relatively simple and cheap, because the process is low pressure, unlike injection

moulding. The wall thickness of parts is more uniform and it is possible to alter the wall thickness without changing the mould. Complex parts with undercuts and intricate contours can be manufactured relatively easily. There is also very little waste as the required weight of plastic to produce the part is placed inside the mould.

The ever-changing nature of this industry means that it is very important for those involved in the manufacturing operation to keep abreast of the advances that are being made. The industry is becoming more competitive and customers are making increasing demands in terms of part quality and performance.

Rotational moulding is becoming a highly sophisticated manufacturing method for plastic parts. New mould and machine features, and advanced process control technologies, are being developed. This gives designers, and end users, access to new opportunities to create novel and innovative plastic mouldings. New technologies such as mould internal air temperature measurement; mould pressurization and one shot foaming are now available. [8]

2.1. THE ADVANTAGES OF ROTATIONAL MOULDING

Unlike other plastic moulding processes, rotational moulding results in seamless parts with uniform wall thickness and more material in corners, to absorb shocks and stresses where they occur most. Since the material isn't stressed during production as in thermoforming, the finished part is stronger. Plus, the moulds don't need to be designed to withstand the high pressures of injection moulding. Since the mould has no internal core to manufacture, tooling costs are lower in that regard as well and minor changes can be easily made to existing moulds.

Rotational moulding also offers superb flexibility and precision. Complex contours, metal inserts, and moulded-in threads can be designed into the walls – requiring fewer steps to get to the finished product. And the colour can never crack or chip off, because it's moulded-in, all the way through. Of course, this means no painting is required.

The following picture is a traffic sign moulded as a seamless, single piece part with two different coloured resins.

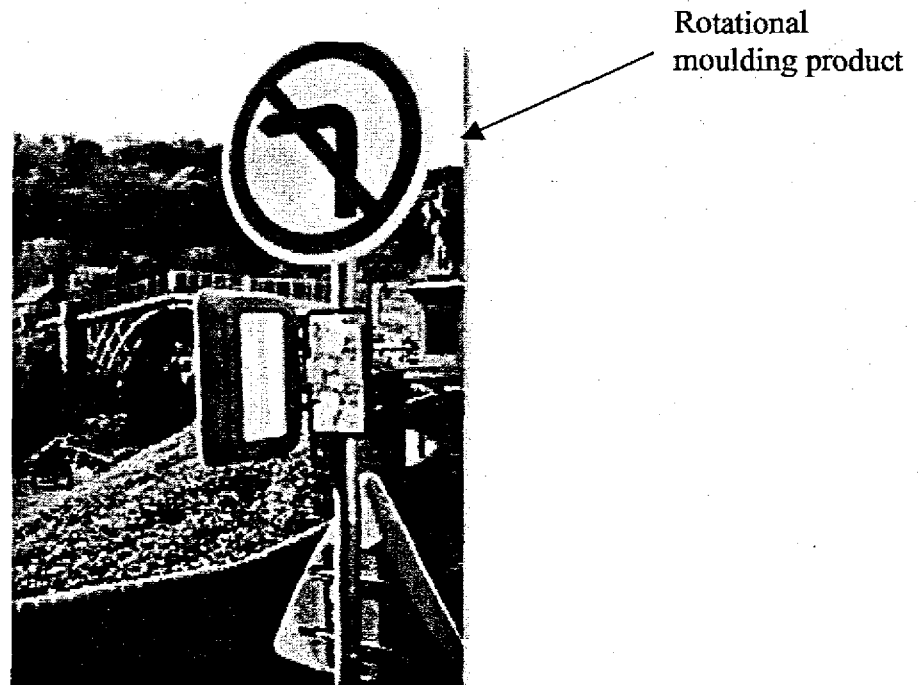

Figure 2.4. Traffic sign product [3]

Generally lighter in weight than metal or fibreglass, rotation moulded plastic products are easy to handle and less expensive to ship. They're tougher than injection moulded parts, long lasting, and corrosion-proof.

The advantages of rotational moulding include:

2.1.1. DESIGN ADVANTAGES

Rotational moulding offers design advantages over other moulding processes. With proper design, parts that are assembled from several pieces can be moulded as one part, eliminating expensive fabrication costs. [3]

The process also has a number of inherent design strengths, such as consistent wall thickness and strong outside corners that are virtually stress-free. If additional strength is required, reinforcing ribs can be designed into the part.

Rotational moulding delivers the product the designer envisions. Designers can select the best material for their application, including materials that can meet some special requirements. Additives to help make the part weather resistant, flame retardant, or static free can be specified.

Size is no limitation. Products can range in size from ear syringes to 45,000-liter tanks.

Rotational Moulders can add colour with pigment applied to the powder or paint applied to the finished product. Textures such as wood, leather grains or fluting can be designed in.

Metal inserts can be moulded in. Minor undercuts are possible – without the need for draft angles. Threads, handles, flat surfaces or fine surface detail can all be part of the design. Designers also have the option of multi-wall moulding that can be either hollow or foam filled.

2.1.2. COST ADVANTAGES

When cost is a factor, rotational moulding has the advantage over other types of processes as well. In comparison to injection and blow moulding, rotational moulding can easily produce large and small parts in a cost effective manner. Tooling is less expensive because there's no internal core to manufacture. Since there is no internal core, minor changes can be easily made to an existing mould. [3]

And because parts are formed with heat and rotation, rather than pressure, moulds don't need to be engineered to withstand the high pressure of injection moulding.

Production costs for product conversions are reduced because lightweight plastics replace heavier, often more costly materials, which make rotational moulding as cost effective for one-of-a-kind prototypes as it is for large production runs.

2.1.3. TECHNOLOGICAL DEVELOPMENTS

Some break through technological developments in recent years has increased rotational moulding's accessibility and effectiveness. Here are some new areas of application:

Urethane foam used to fill rotationally moulded parts:

For added stiffness and structural strength, double walled rotational mouldings are filled with polyurethane (PU) foam. For products such as boats, the foam in some instances provides permanent buoyancy.

Structural foam moulding:

Large, thick-walled, lightweight parts can be rotationally moulded using a multistage process that produces foam mouldings having a solid outer layer. Different materials can be used for each layer. For instance, each layer could be a different colour, the outer layer could be impact-resistant polyolefin compound, or the inner layer could be a post consumer resin.

Powders based on post consumer resins:

Pressure from environmental groups is leading some rotational moulders to use post consumer resin (PCR) in their products. Most commercially available PCR's are made from high-density polyethylene (HDPE), which results in resins having lower melt indexes than do typical rotational moulding resins. For rotational moulding, HDPE PCR is blended with virgin resin with content ranging from 10 to 25 percent.

Moulds that do not require release agents:

Coating a rotational mould with fluoropolymer can improve a part's surface gloss and smoothness and reduce manufacturing costs. The fluoropolymer coating allows the polyolefin melt to flow more uniformly, which can significantly reduce pinholes in the surface of moulded parts. A fluoropolymer-coated mould can sometimes eliminate the need for an expense of repeatedly spraying the mould with a release agent.

Moulded-in graphics:

Embedding a graphic into a rotational moulded part is a possible addition that won't peel off. Neither surface pre-treatment is required, nor post manufacture painting.

2.2. SOME ROTATIONAL PRODUCTS

The following figures show the range of the rotational products from smaller to big.

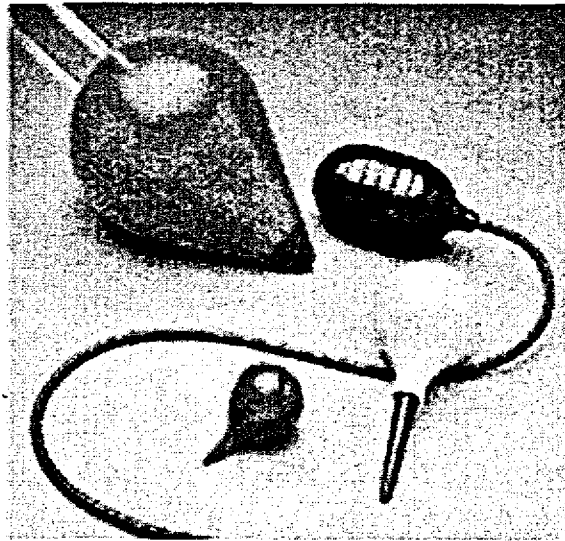

Figure 2.5. Various small size rotational mouldings [5]

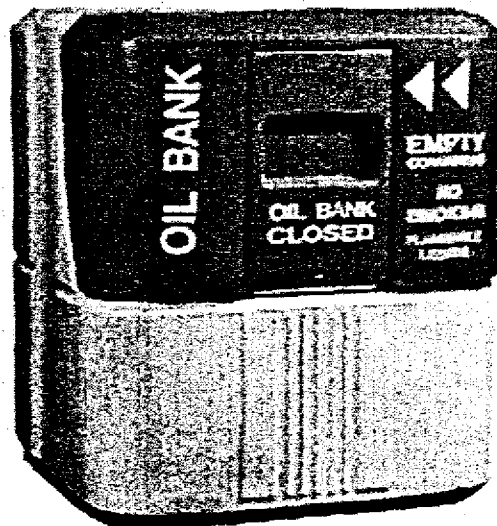

Figure 2.6. Large size rotational moulded oil recovery bank [5]

These larger size rotational moulded products being a lot more popular as there are many processes suited for smaller plastic parts but only very few for making the parts of the size shown in figure 2.3. Large size products typically include:

- Specialty tanks and containers for fuel, water, and chemical processing:
- Livestock feeders
- Drainage systems
- Food service containers
- Instrument housings
- Vending machines
- Highway barriers and road markers

Recreational, special application, toy, and transportation:

- Boats and kayaks
- Childcare seats
- Light globes
- Tool carts
- Planter pots
- Playing balls
- Playground equipment
- Headrests
- Truck/cart liners
- Air ducts

2.3. SOME DISADVANTAGES OF ROTATIONAL MOULDING

- Hollow parts can be moulded quite efficiently with this process yet internal ribbing is not possible.
- Wall thickness is constant making variations difficult to control. Thickness can range from 1.5mm to 12.0mm.
- The process is relatively labour and material intensive, especially if multiple parts are moulded in one cavity and have to be separated.

2.4. COMPARISON OF ROTATIONAL MOULD AND INJECTION MOULD

In this research project, only rotational moulds are going to be investigated on account of virtually no internal pressure. This give a much greater tolerance to additional split lines. The main difference between rotational mould and plastic injection mould are:

- Moulding equipment are different
In plastic injection moulding, the traditional plastic injection machines are used. It consists of heating system, injection system, clamping system, and mould opening system. In rotational mould, the equipment consists of three different stations, namely loading, heating, and cooling station.
- The pressure inside the cavity are different
In the plastic injection moulding, there is a high injection pressure existing inside the mould cavity. And because of the high pressure inside the mould, it needs a strong clamping system. In some big injection machine, the clamping force can be above 300 Tons. The rotational moulding has a very low cavity pressure because the plastic resin has already been put inside the cavity before it is heated.
- The material of the moulds are different
Most of the rotational mould can be made using aluminium, while most of the plastic injection moulds are made of tool steel.
- The cycle time for products are different
The rotational moulding is a slow process; it can take as long as 30 minutes to make a single product. In most cases, injection moulding has a short cycle time for a single product.
- The plastic resins are different for these two moulding processes
In injection moulding, the most popular resins are: ABS, PC, PP, etc.
In rotational moulding, the most popular resins are: polyethylene.

CHAPTER 3 INDUSTRIAL SOFTWARE USED

Currently there are many software packages that are being widely used in manufacturing industry for product design, mould design and mould manufacture. The two principle types of software used are 3D CAD packages for drawing, design and 3D computer model creation of both products and moulds and also CAM packages for toolpath creation to do the CNC cutting of the moulds. In fact most CAM packages include CAD functionality. The stand-alone CAD packages however generally include many more 3D model creation tools. Among the more popular 3D CAD packages there are Pro/Engineer, AutoDesk's Inventor and Mechanical Desktop, also Unigraphics NX 3, SolidWorks and SolidEdge. Pentech owns licenses for AutoDesk's Inventor and Mechanical Desktop, also Unigraphics NX 3 and SolidWorks. Among the more popular CAM packages there are MasterCAM and EdgeCAM. Pentech owns licenses for EdgeCAM. In projects of this nature very often the choice of software ends up being a matter of which ones the Institution owns licenses for because these packages come at prices well in excess of R100 000. Thus the CAM choice was already made. The rotational moulding partner company uses SolidWorks CAD software and hence that choice was also natural.

3.1. SOLIDWORKS

Of the CAD 3D solid modeller and draughting packages, SolidWorks turns out to be one of the more affordable options and hence is very widely used in South Africa. It will be used in this project for minor edits to CAD models of products supplied to Pentech by Atlas Plastics, for creating CAD models of the moulds from these products and for CAD models of test pieces jigs etc. which will need to be manufactured during the cause of the project. At the start of the project the current version of SolidWorks was Version 2001 Plus. This increased to Version 2003 and then Version 2004. The needs of the project did not require the added work to keep upgrading and hence only Version 2001 Plus was used for the duration of the project.

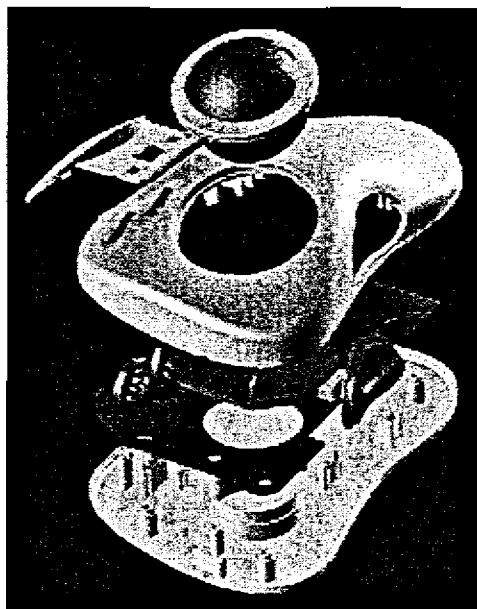

Figure 3.1. An exploded CAD assembly model made up of separate CAD part models all created in SolidWorks

3.2. EDGE CAM

EdgeCAM has two modes, the Design Mode in which it can be used as a CAD package and the Manufacture Mode for the CAM work. In this project it will largely be used for CAM work. At the start of the project the current version of EdgeCAM was Version 5.75. This increased to Version 7.5 and then Version 8.75. Version 7.5 came with a lot of improvements to the simulation of actual cutting and hence was implemented. Version 8.75 came with facilities to assist in large-scale teaching and thus had to be implemented. Note that for different parts of the project, different versions have been used depending as to which version was in-service at the time. EdgeCAM can read in SolidWorks part files directly so no drawing exchange file types are necessary with the hassles that can bring.

EdgeCAM has libraries of all the CNC milling and CNC turning cutters and many different toolpath types. The rather large array of toolpath types is a big plus on this type of software. Features are chosen on the 3D CAD solid model and the relevant toolpath button selected and the toolpath is created from there it is just a matter of the settings of the toolpath. The settings of the toolpaths are where most of the problems occur and are fixed. Once the toolpaths are checked and cross-checked by various simulations etc. a machine specific postprocessor is used to get the NC file for the CNC machine tool which is going to be used to do the machining. For this project, the NC file would be used to cut the part on either the CNC milling machine or the CNC lathe. One of the nice features of EdgeCAM is that these postprocessors, which come with the package, are totally customisable to suit the needs of any machine.

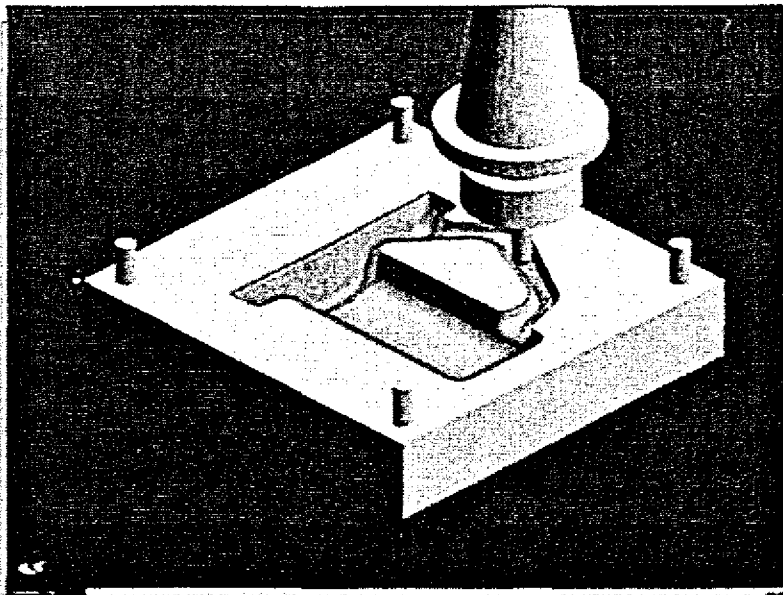

Figure 3.2. EdgeCAM milling simulation, one view

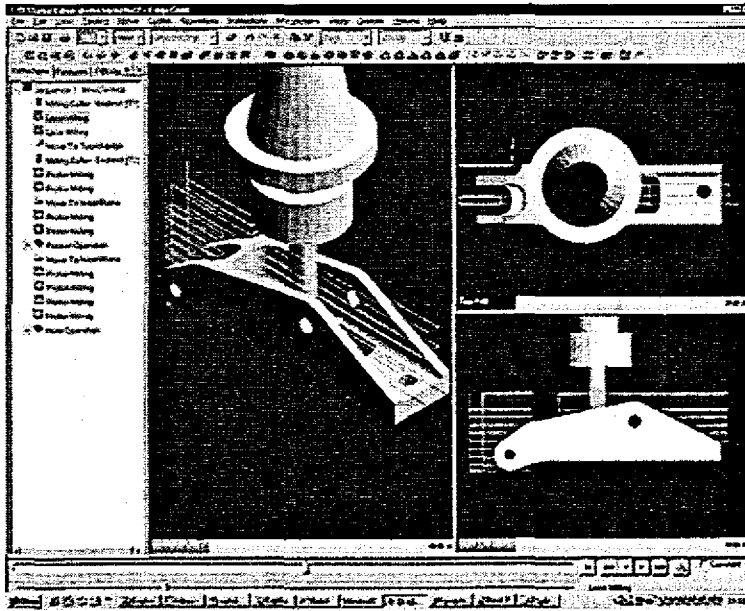

Figure 3.3. EdgeCAM milling simulation, multi views

CHAPTER 4 OPTIMUM SUBDIVISION OF MOULD HALVES

Rotational moulding is one of the most cost-effective moulding methods; it can be used to produce complex parts that have features such as intricate contours, undercuts, moulded-in inserts and double walls. So the design for rotational mould in some cases is complex too, depending on the products' features.

These two products can demonstrate the complexities of the rotational products:

- 1) Floor sweeper frame: It combined 120 metal parts into one rotational moulded part, reducing assembly time and increasing product integrity and durability.

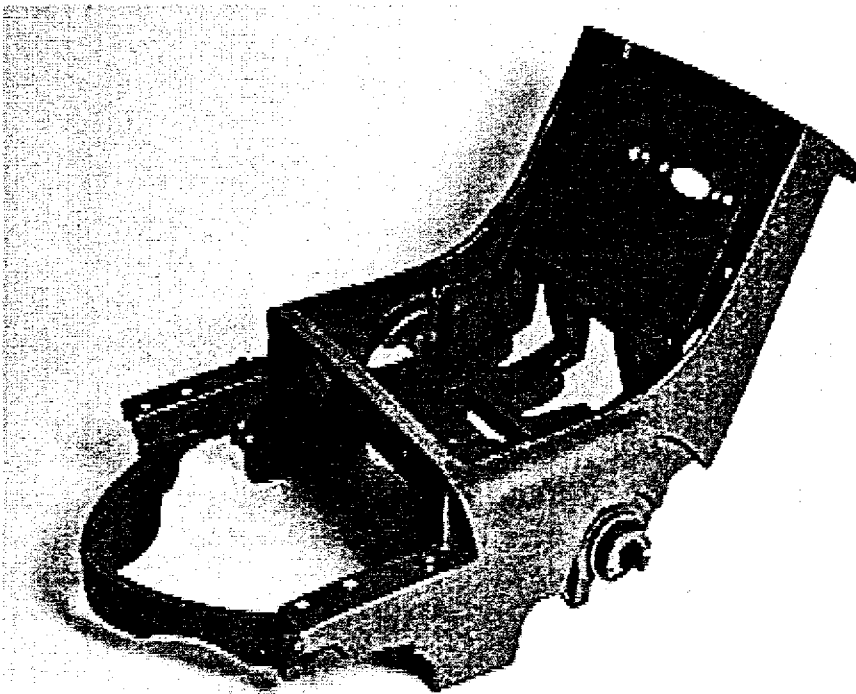

Figure 4.1. Rotational moulded floor sweeper frame part [3]

- 2) Used coolant reservoir: It has a complex shape that lends necessary strength to the part. Due to its complex shape, this part could only be produced by rotational mould.

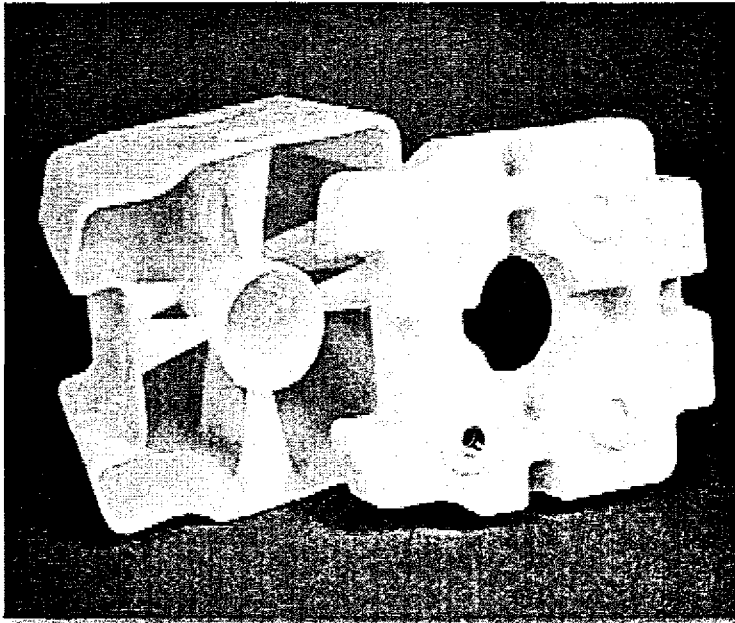

Figure 4.2. Rotational moulded used coolant reservoir part [3]

Basically, no matter how complicated a rotational mould is, a large size rotational mould half can theoretically be split into some small size parts, so the small size parts can be machined at the small or medium size CNC machines, and then the small mould parts can be assembled together to form a large size mould. This is the principle strategy used in this research propose. In this chapter, one large size rotational mould is going to split to demonstrate this principle.

4.1. OPTIMUM SUBDIVISION OF A WATER TANK ROTATIONAL MOULD

Water tank products are popularly moulded by rotational moulding since the water tanks are normally of a very large size. It is impossible to have such a huge injection machine to hold such a large size injection mould if the water tank was moulded by injection moulding. In this design, the size of the water tank is: $\text{Ø}500 \times 2200 \text{mm}$.

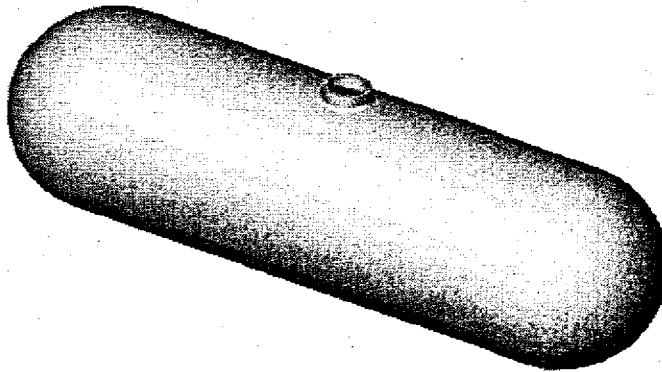

Figure 4.3. The water tank product

Consider the case where only two mould halves are used for this water tank:

If this water tank rotational mould is to be made from a two-piece mould out of single large size workpieces, then the mould halves will look like the following:

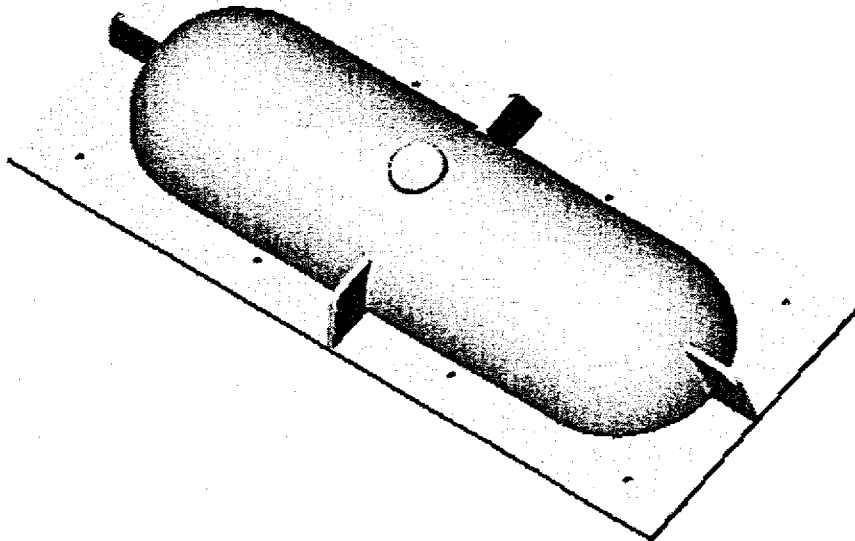

Figure 4.4. Water tank mould top half

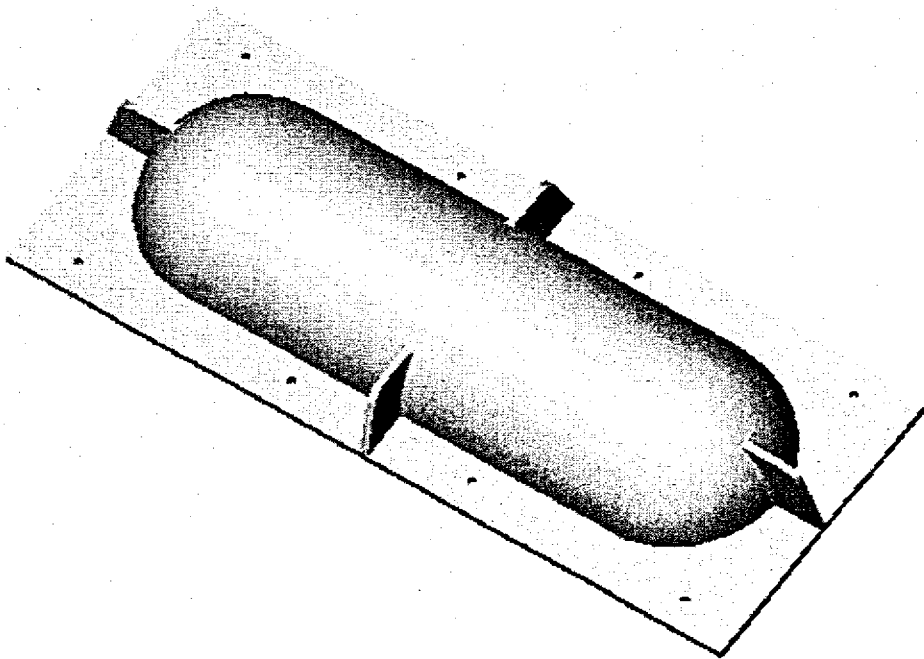

Figure 4.5. Water tank mould lower half

From this two-half mould design, the rotational mould can only be machined on a very large size CNC milling machine from single very large size workpieces. The worktable size of the CNC milling machine to be used would have to be at least 3000x1500x1500mm. Currently in the South African mould making industrial, it is very difficult to find such a big CNC machine. So, the alternative approach would be to re-design the mould, splitting the two halves to many small segments, so that each segment can be manufactured on most readily available medium size CNC machines. Further more, the small mould segments can be manufactured at different machine shops using a subcontracting methodology in order to shorten the mould making lead-time.

Consider a more optimum mould subdivision:

The re-design will split each mould half into five smaller segments, and each segment will have the size at about 300x400x800mm. This kind of workpiece can easy to be clamped and manufactured at any medium size CNC machine.

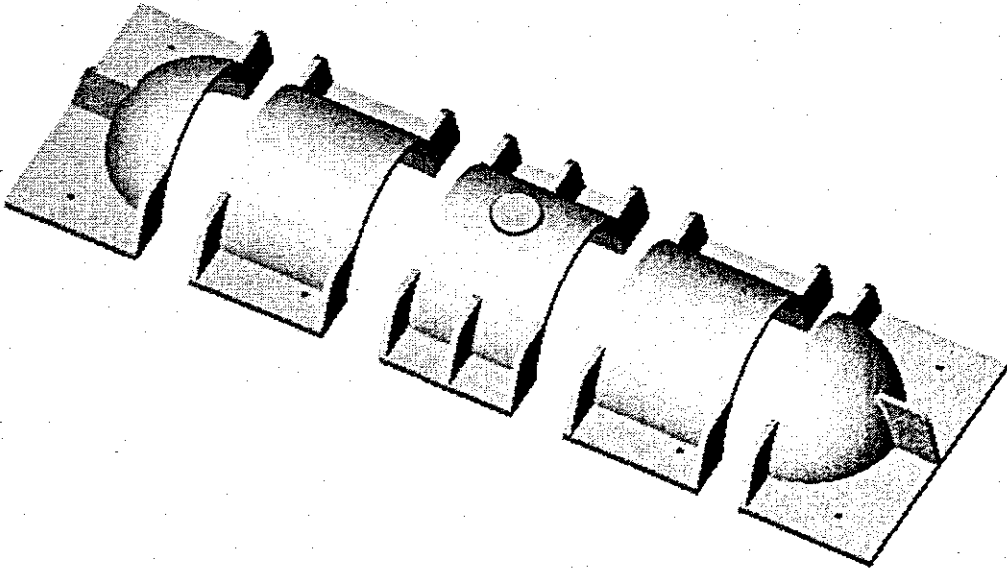

Figure 4.6. Mould segments of the mould top half

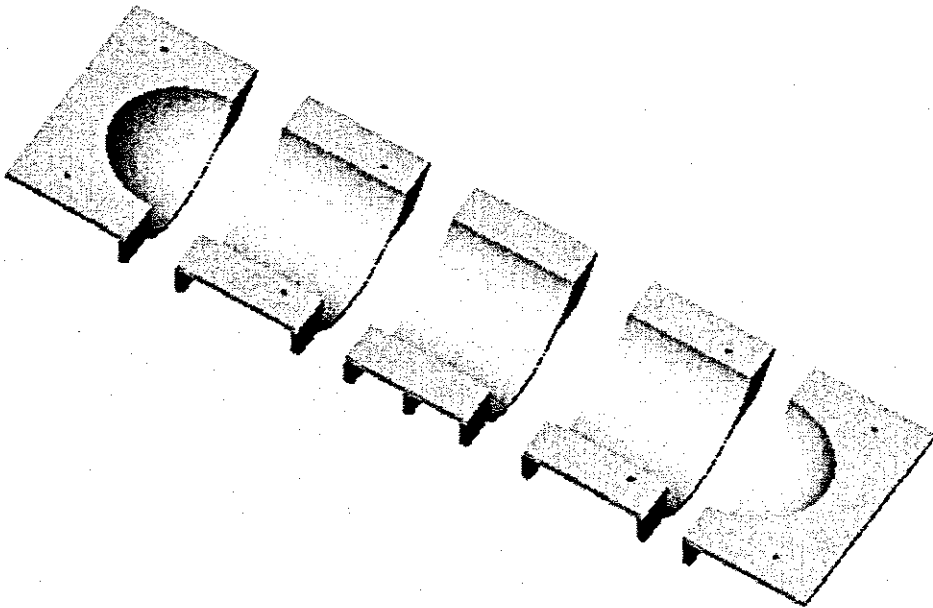

Figure 4.7. Mould segments of the mould lower half

4.2. WHAT SHOULD BE TAKEN INTO CONSIDERATION WHEN SUBDIVIDING ROTATIONAL MOULD HALVES

- Each mould segment should be small enough to be clamped in the toolmaker's medium size CNC machine. Pentech's CNC milling machine can cut jobs of a maximum size of 800mm x 500mm x 500 mm. If the workpiece size is fairly close to this maximum then a clamping frame as used in the following chapter becomes essential.
- Both mould halves should be split into same number of segments.
- All possible attempts should be made to keep all segments as similar in size and shape as possible.
- Extra ribs should be added to the additional split lines along segment boundaries in order to act as return flanges where boltholes and dowel pins can be located for mould half assembly.
- Split lines should be chosen according to product cross-section lines. For example, this water tank mould has a split line between the arc surface and the flat surface. This approach simplifies machining as well as assembly.

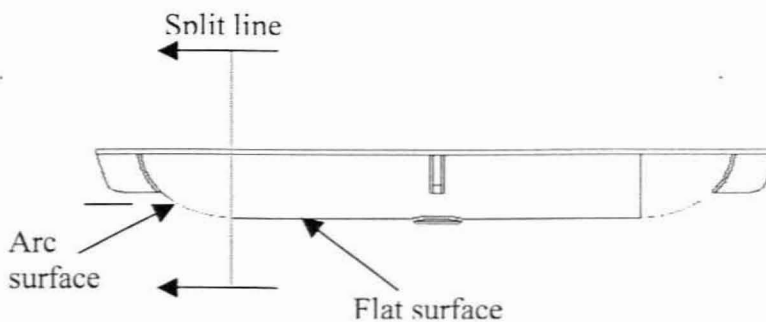

Figure 4.8. Choosing a split line

- Attempt to keep all flanges, return flanges either vertical or horizontal. This ensures that they can be cut flat without scallops using the blade end edges or the blade side edges of an end mill cutter on a 3-axis machine. The smooth, flat surface is imperative for mould sealing on assembly.
- Another issue to keep in mind is the fact that there is a relationship between pocket fillet radius and maximum depth of pocket. This results from the fact that pockets with internal fillets and undulating shapes are cut using ball nose cutters. Typically a $\varnothing 3$ ball nose cutter has a maximum cut depth of 20mm and a $\varnothing 6$ ball nose cutter has a maximum cut depth of about 60mm and so on.

CHAPTER 5 SMALL SIZE ROTATIONAL MOULD

First up it was decided to start off with a small size rotational mould where all parts would definitely fit on Pentech's medium size CNC milling machine. Here the primary goal was to confirm that Pentech had both the infrastructure and required skill to make a rotational mould of any sort. It would also give Pentech an idea of lead-time for the whole process as no such mould had been made in the Department workshop before. This small size mould has two added objectives. Firstly, the proposed frame type work holding method to be used on the larger mould parts is to be tested. Secondly, the concept of making more than one part from one aluminium billet and then slitting then on the holding frame, as a last step will be tested. Atlas Plastics provided the CAD 3D model and aluminium material for the manufacture of the rotational mould.

The product is a miniature of a 220 l drum that Atlas Plastics make, which will be used for marketing purposes. The mould consists of four different parts, vis-à-vis a top, bottom, and two different sides. Note this is not two halves split into four parts. The undercuts on the product demand a four-part mould.

The only purpose of manufacturing the reverse side is to cut away stock to ensure the parts have a thickness of 5 mm. So the toolpath for the reverse side are usually rougher than the inside surfaces. The last step is to use a 2D profile toolpath to depart the four parts from the big workpiece at the reverse side.

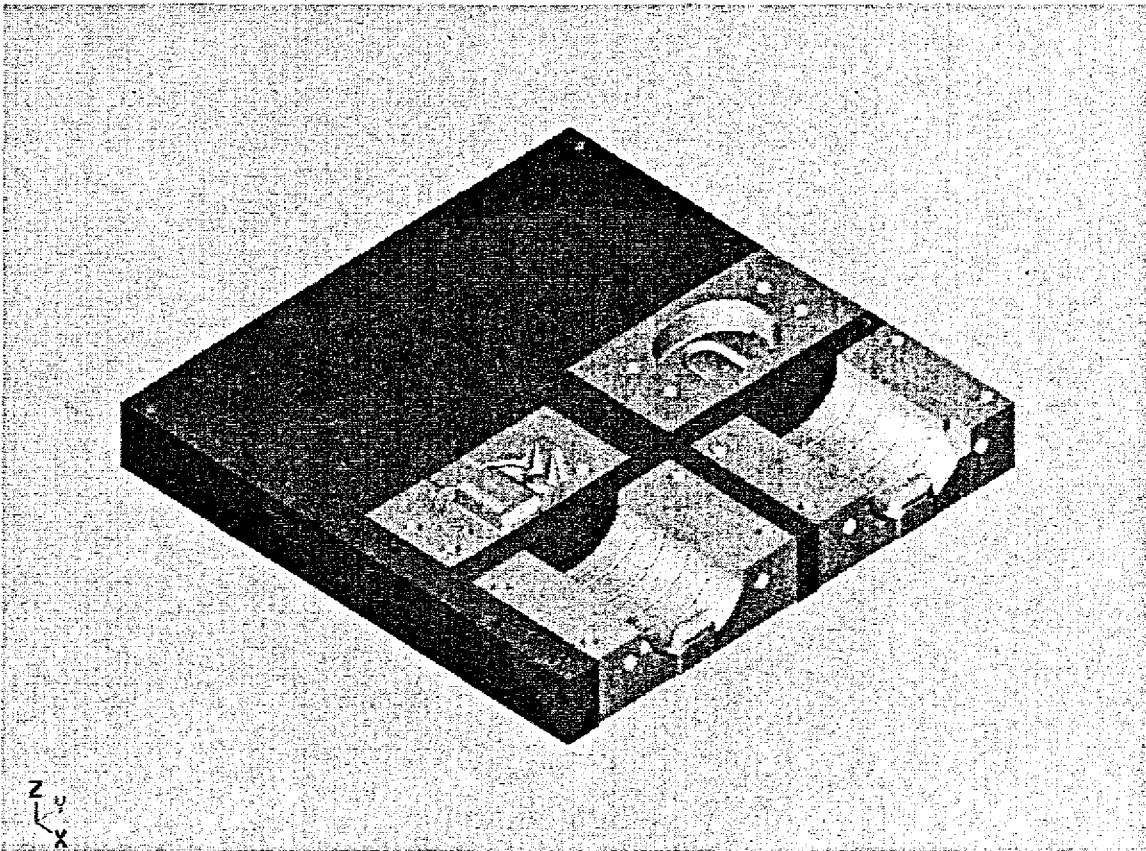

Figure 5.1. CAD drawn rotational mould parts inserted into available billet

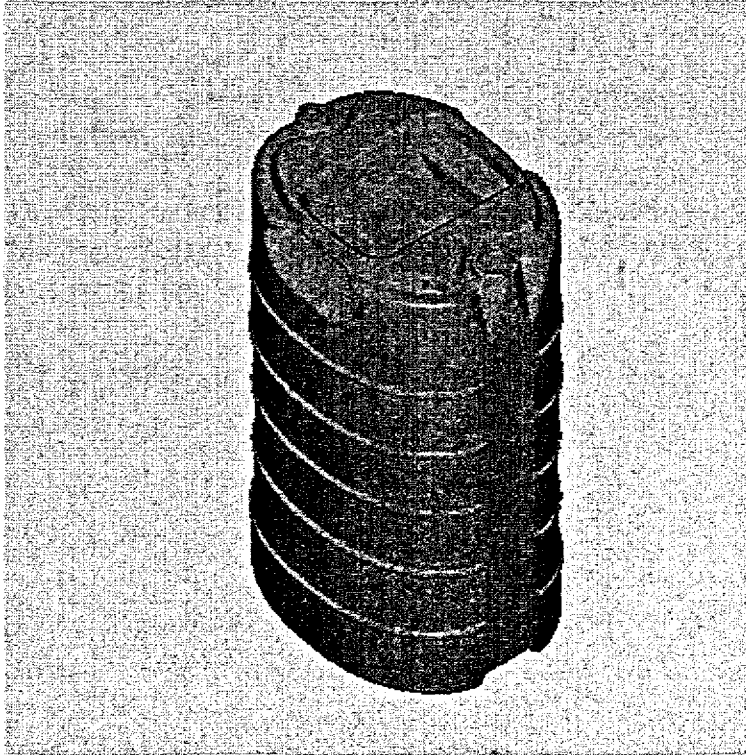

Figure 5.2. Top view of CAD designed product
(Compliments of Atlas Plastics)

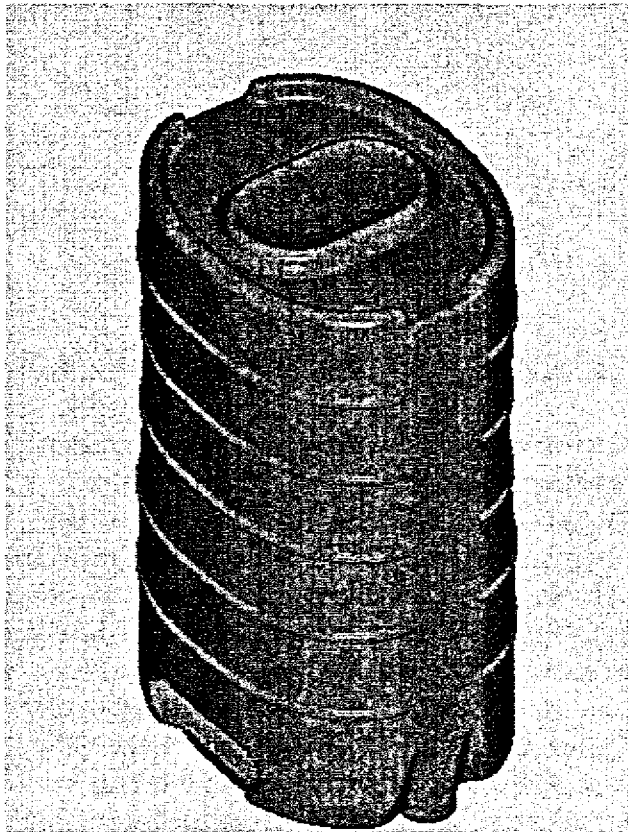

Figure 5.3. Bottom view of CAD designed product
(Compliments of Atlas Plastics)

5.1. WORKPIECE

The workpiece consists of an aluminium billet of 430 x 430 x 60 mm. The workpiece is going to be cut on both sides, i.e. product side and reverse side.

The workpiece has four clamping holes as showed in the following figure. Because of the layout of the parts, the workpiece is not symmetrical so the four holes are not symmetrical about the x-axis.

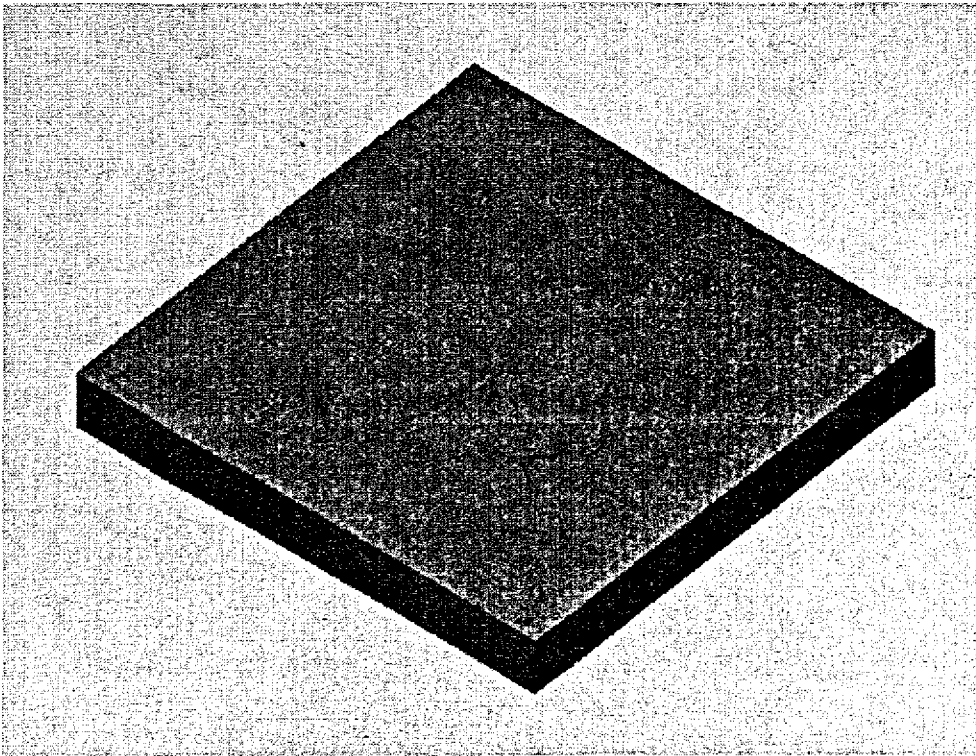

Figure 5.4. Aluminium workpiece

5.2. CLAMPING FRAME FOR THE WORKPIECE

The idea of holding the workpiece from below with a rectangular frame came from Mr. Gary Lategan of Atlas Plastics. He had seen that the rotational mould makers in Italy, where all his very large moulds are made, use this clamping technique on all their workpieces. The clamping frame is made from 40 mm mild steel square tubing. The idea seems simple but it is in fact ingenious. The reverse side of any mould part can always be designed to have four threaded holes flush on the frame. M10 or M12 cap screws are then used from the frame upwards. If the mould part is well planned and designed then these clamping holes can be reused as assembly holes on the flanges when assembling the mould halves. In figure 5.6 notice how the clamping frame protrudes both left and right from below the workpiece. It turns out that mostly milling machine tables are a bit longer in the x-axis that the machining volume is. This is true of Pentech's CNC milling machine. It can machine an x-length of 800mm and the worktable is 1000mm long, leaving the 100mm on each side where the T-bolts can be bolted through the protruding clamping frame.

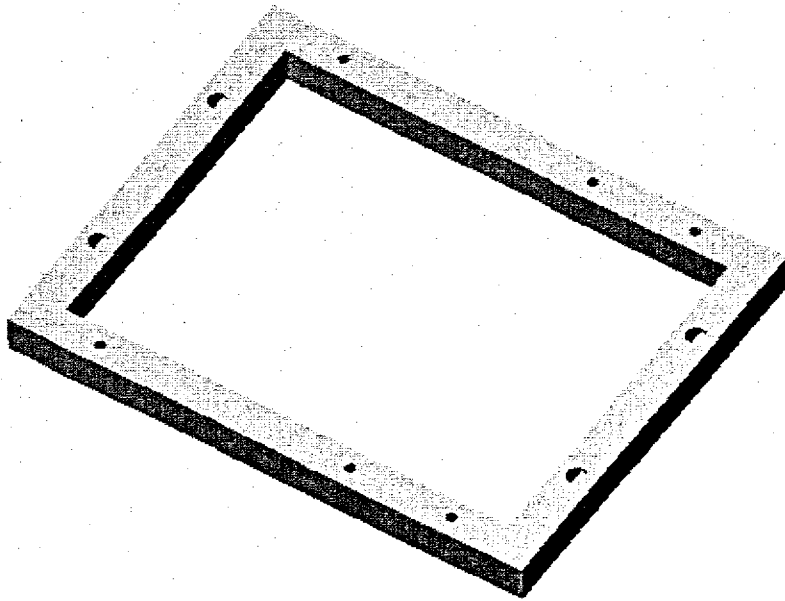

Figure 5.5. Steel workpiece clamping frame

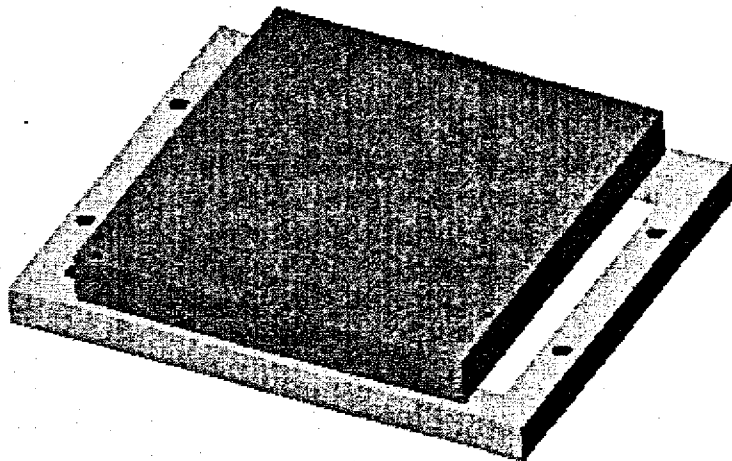

Figure 5.6. Workpiece mounted on the clamping frame

5.3. MILLING CUTTERS USED FOR THIS JOB

The cutter type is one of key factors to get the best surface finish and also the highest machining speed. For this job the following cutters have been selected:

Endmill cutters:

- Ø40mm, HSS, used for facing the flanges
- Ø20mm HSS, used for the profiling toolpath that separates the mould parts
- Ø12mm HSS long reach (long reach cutters only available in HSS), used in a 2D profile toolpath to finish vertical flange walls.

Bullnose cutters:

- Ø20mm, insert radius R0.4 Seco Turbo mill, used for all roughing both on the product side as well as the reverse side. With Seco insert cutters the highest cutting speeds are achieved, ideal for roughing when minimum cutting time is the only real concern.

Ball nose cutters:

- Ø5mm Tungsten carbide, used to semi-finish the product cavities.
- Ø3mm Tungsten carbide, used to finish the product cavities.
- Ø1.5mm Tungsten carbide, used to pencil mill the corners of the product cavities where the very small fillets are found. The cutting formulas show that a cutter of this very small diameter should be cutting at a spindle speed of between 20 000 and 30 000 rpm. Cutting slow means more cutter breakages. On a medium size milling machine such as Pentech's the maximum spindle speed is 6000 rpm. This fact makes a Ø1.5mm cutter the smallest that is practical and then only to be operated at a feed of about 20 mm/min i.e. feed on the absolute minimum. Note also that such a cutter can only cut a cavity to a maximum depth of about 20mm. These very small diameter cutters require specialized, expensive collet holder i.e. ER16 collets, for tool holding in the spindle.

5.4. CLAMPING FRAME AND WORKPIECE ATTACHMENT HOLES

When drilling the holes on the frame to hold the workpiece, it is important to consider the holes needed for clamping the workpiece on both product and reverse sides. Thinking about the holes required for the reverse side in the beginning will prevent a need to drill more holes after completing the first side before starting the second side.

Holes drilled on the workpiece for bolting to the clamping frame need to be drilled and tapped right through the workpiece or else more holes will need to be drilled after completing the first side of the workpiece. Extra drilling between first and second sides of workpiece will wastes time and cause a loss in hole positional accuracy due to re-clocking. See the following two figures for more clarity.

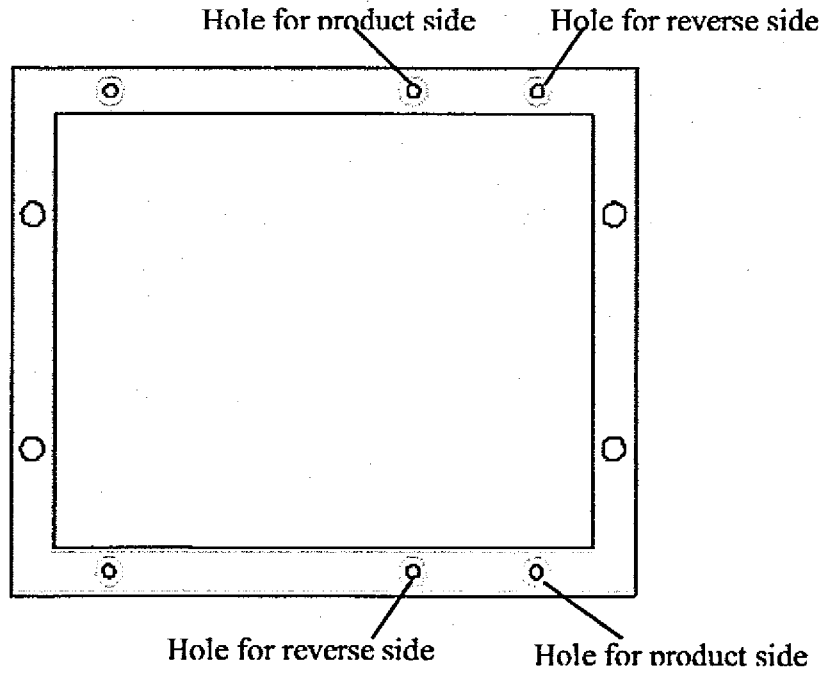

Figure 5.7. Hole arrangement on clamping frame

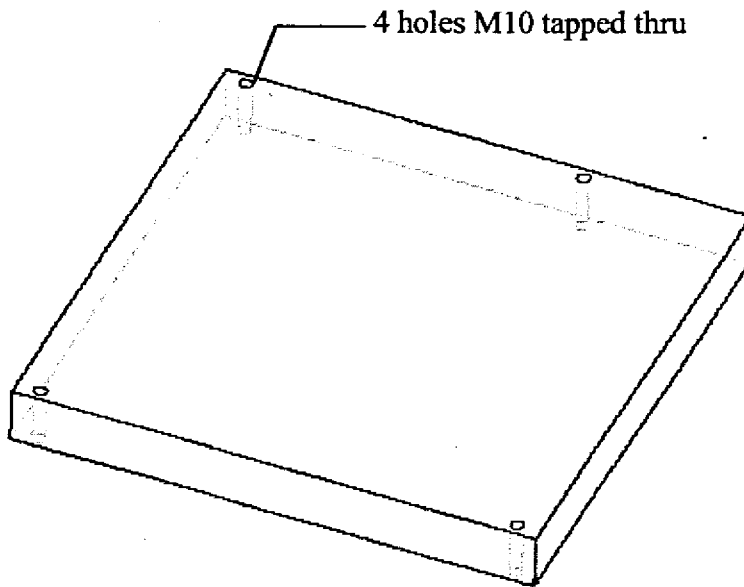

Figure 5.8. Hole positions on workpiece

5.5. MANUFACTURING WORKPIECE PRODUCT SIDE.

The surface finish of moulds product side cavities determines the finish achieved on the product. Thus more attention must be devoted to getting the surface finish of this side correct. First the product side will be machined, then the reverse side and finally the mould parts will be separated.

The following flow can demonstrate the working plan for the workpiece product side.

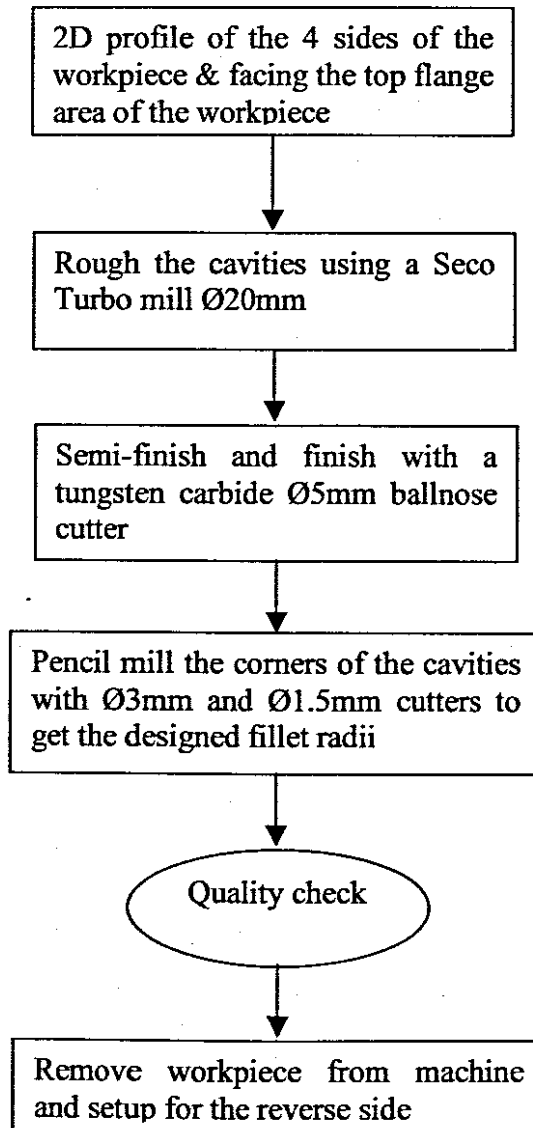

Figure 5.9. Machining steps on mould product side

The workpiece product side was manufactured successfully. The correctly selected cutters and the clamping frame played a key role to this result. The following pictures show the workpiece product side when it was still mounted at the worktable.

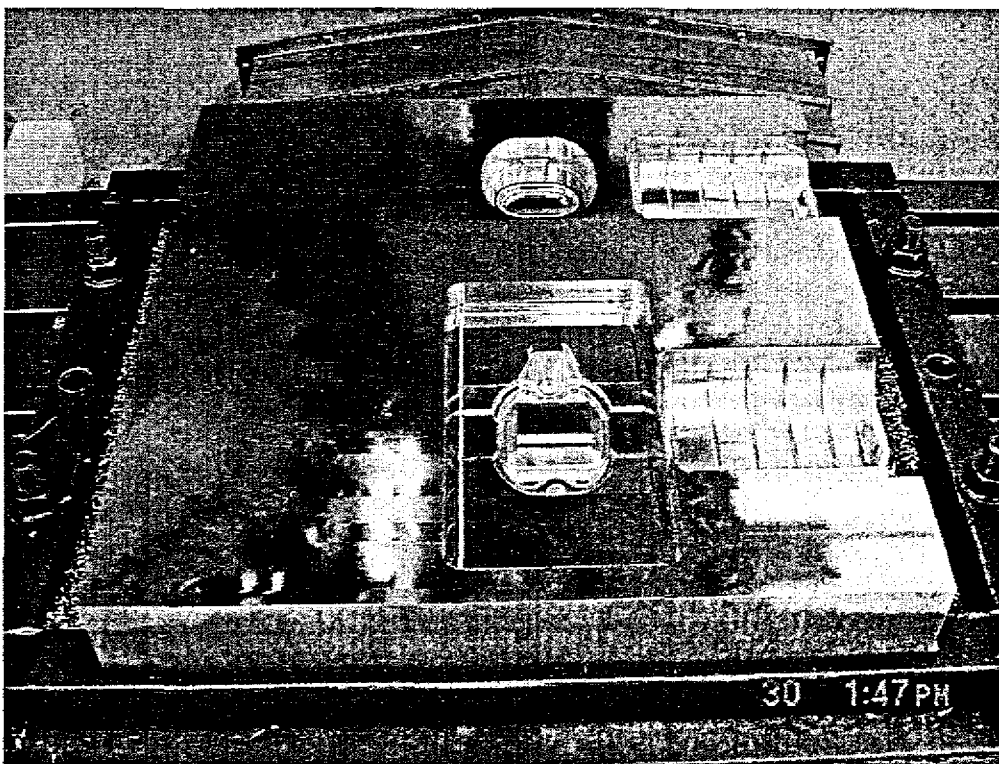

Figure 5.10. Product side of mould parts completed before flipping workpiece

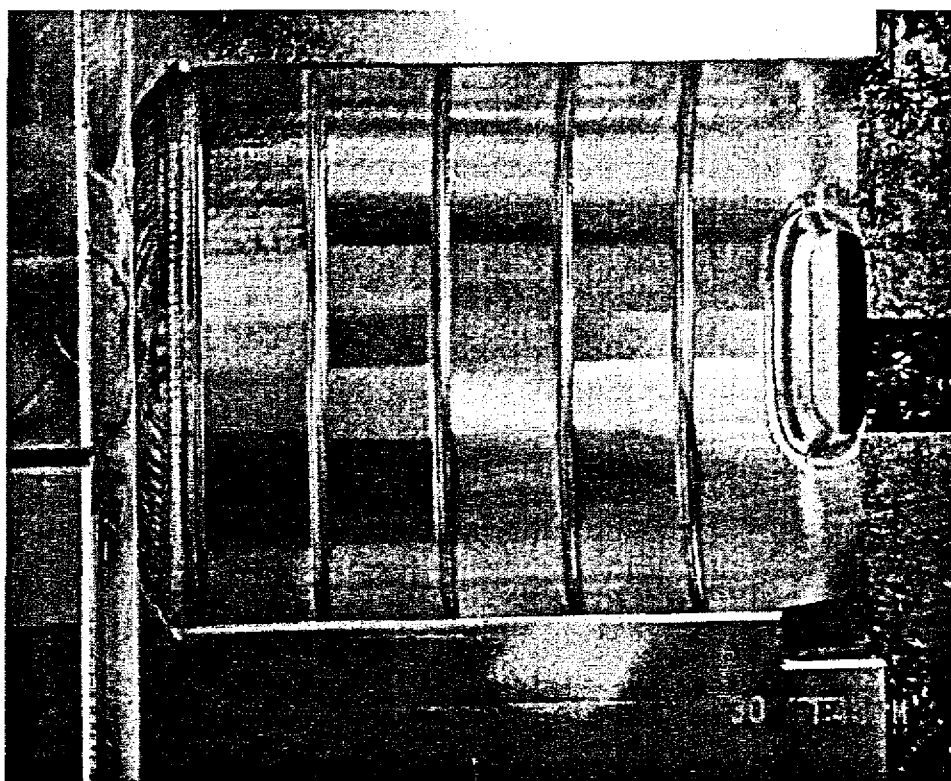

Figure 5.11. Close-up of the drum side cavity

During the machining of this side the following lessons were learned:

1. It is a good idea to give the NC files meaningful names. For example, using **final-detail-a.nc** instead of **j34.nc**, will assist the machine operator to know that this file is for finishing of the first side.
2. The Castrol ClearEdge coolant currently in the CNC machine is not designed specifically for aluminium use. If the coolant is allowed to lie on a machined surface overnight, then in the morning there will be black oxidation marks on the surface. These can be polished out using Brasso, a waste of extra effort. Thus a better coolant will need to be investigated.
3. During the machining of this job, many $\text{\O}1.5\text{mm}$ Tungsten carbide ball nose cutters were broken. This happens especially when it sticks out too far, 20mm maximum. It was discovered that to reduce cutter breakage the best toolpath parameters are: Feed rate 20mm/min, plunge rate 10mm/min and spindle speed 5800rpm. (The maximum spindle speed for this CNC milling machine is 6000rpm)
4. From $\text{\O}3\text{mm}$ Tungsten carbide ball nose cutter breakage during pencil milling it was discovered that when pencil milling vertical corners it is important to machine downwards and not down one side and up the other side. Machining from bottom to top in a vertical corner will add extra lateral forces to the cutter, resulting in small diameter cutters breaking. The parameters needed for the $\text{\O}3\text{mm}$ Tungsten carbide ball nose cutter are: depth of cut at 0.25~0.12mm, feedrate 48mm/min, plunge-rate 24mm/min and spindle-rate 5800rpm.
5. A problem was experienced with getting the simulation time and the real cutting time to correlate. It was realized that the problem lay in the rapid movement time calculations by the software. It was a matter of setting the software rapid speed. The CNC machine has a maximum rapid feedrate of 12 000mm/min. So when the rapid feedrate override on the machine is set at 50% during the milling, the value for the rapid feedrate in the post processor should set to 6000 mm/min. This setting seemed to correct the situation.
6. The simulation function of the software is very important and helpful, especially from Version 7.5 onwards. Many toolpaths have been changed due to bad simulation results and after the changes to the toolpaths the quality surface finish greatly improved, as well as having the lead-time shorten. For example, from simulation it was seen that using a Surface Scallop Toolpath on a vertical walls gave a poor surface finish. When this toolpath was changed to a Surface Contour Toolpath, the product cavity ended up with a very good finished surface.
7. Experience here showed that in the toolpath settings the parameter, "stock to leave" was best set at 0.5mm for roughing, 0.2mm for semi-finishing and then obviously 0.0mm for finishing. In this way, the cutting force loading is kept low enough to reduce cutter breakage, especially with the smaller diameters used for semi-finishing and finishing.

8. As already mentioned deep product side cavities and small fillet radii are a problem because small ball nose cutters very short since they do not handle lateral forces. An ER16 baby collet chuck extension was used to hold the small ball nose cutter to get into these cavities. There is still always the risk of the collet chuck nut rubbing the sidewalls of the cavity thus great care must be taken with the toolpath simulation. The exact shape of the baby collet chuck was programmed into EdgeCAM's tool library and the simulation carefully watched for any collision detection. Earlier versions of the software did not report collision detection well at all.

5.6. MANUFACTURING WORKPIECE REVERSE SIDE

The purpose of cutting the reverse side is to ensure the mould parts have a constant thickness of 5mm for purpose of heat transfer. Better heat transfer is achieved with a very rough reverse side. In fact, "the rougher, the better" according to Mr. Gary Lategan of Atlas Plastics. Thus only a convenient roughing toolpath is applied. The "Step Down" parameter of the toolpath determines the step level giving the roughness. This is set to the maximum Depth of Cut that the tool will cut without problems. The roughing was done with a Surface Pocket Toolpath. After the roughing, a 2D Profile Toolpath is used to separate the four independent mould parts from the workpiece remainder.

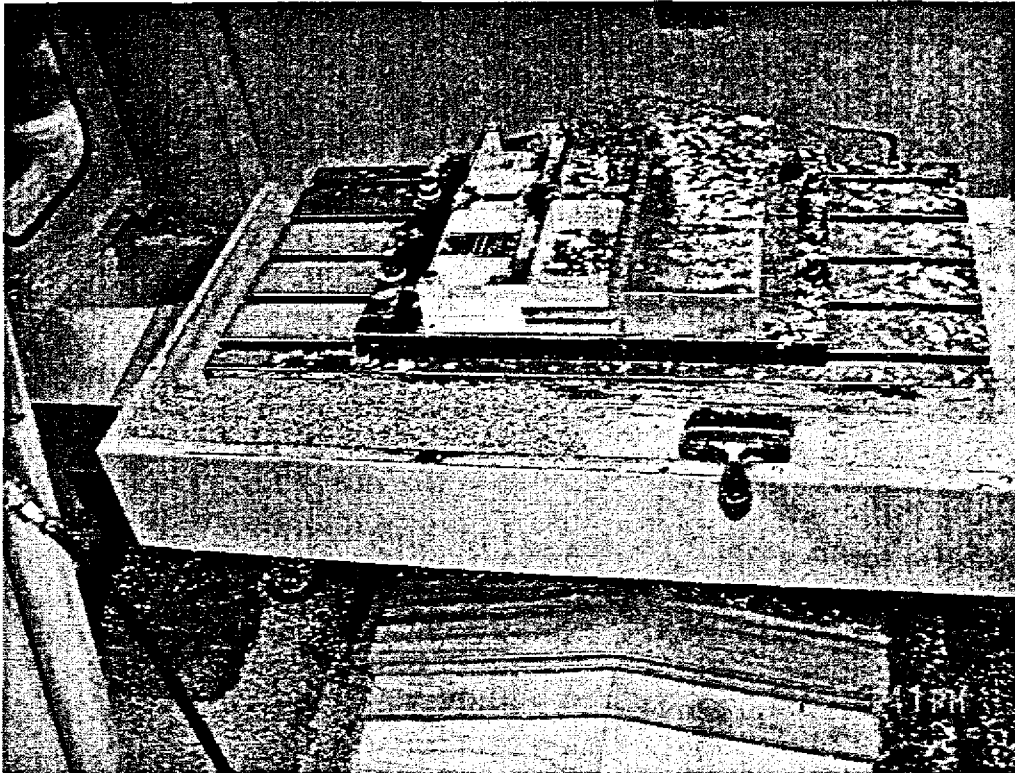

Figure 5.12. Mould reverse side in process on CNC milling machine

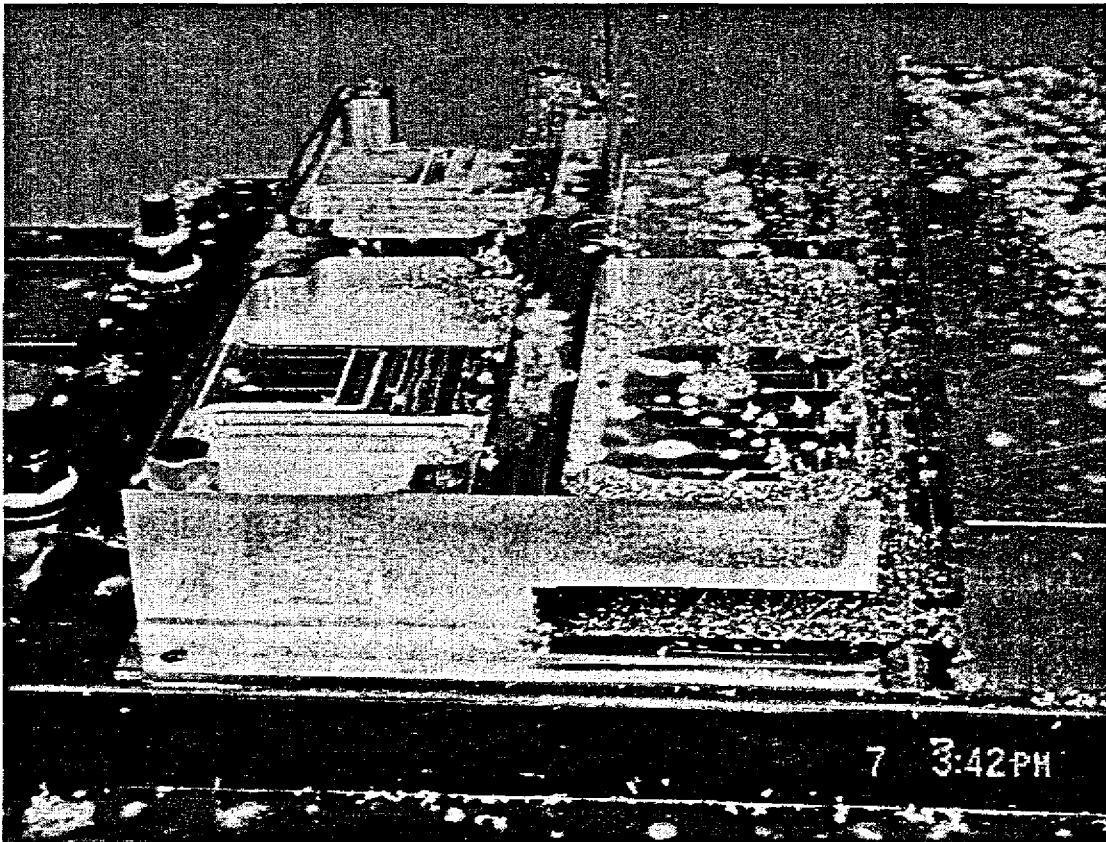

Figure 5.13. Mould reverse side in process on CNC milling machine

The reverse side was machined without any problems. The same is not true for the slots to separate the four mould parts. The slot gap was modelled at 20mm and then a $\text{Ø}20\text{mm}$ slot drill cutter was used to cut this slot. It broke because as it cut, the workpiece parts tended to release and pinch the cutter. Clearly a circular 2D Profile Toolpath was needed and not a Slot Toolpath. A $\text{Ø}16\text{mm}$ slot drill cutter was then used with the circular 2D Profile Toolpath to finish the job.

A 2mm thick bridge (See figure 5.14) was left at the bottom of the separation slots while the vertical side walls of the four mould parts were finish cut with the side of the slot drill. The 2mm thick bridge proved to supply enough rigidity for the side milling. This was a cause for concern.

As a last step the 2mm remainder was then cut through using a 0.1mm offset on the vertical sidewall profile to a finishing Z-offset of 0.1mm as well. A tin snips was then used to cut through the last piece of tin foil before a rather large burr could be filed off. In retrospect a Z-offset of 0.0mm would have been better. The mould pieces tend to lift a little at the end and the aluminium pushes out of the way rather than getting cut. Thus even at a Z-offset of 0.0mm there would still be the tin foil remainder but it would have been thinner for the tin snips to handle more easily.

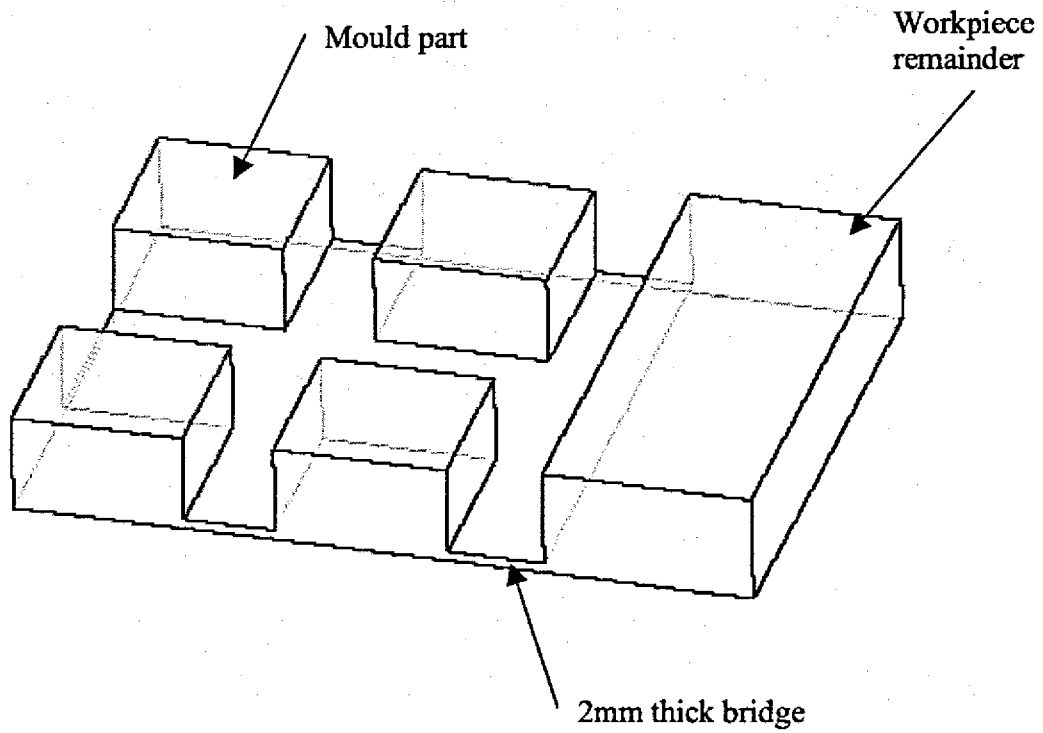

Figure 5.14. Mould part separation slots

5.7. POST CNC MILLING TASKS

- Debur all the finished parts
- Using Brasso to polish all the parts.
- Assemble the four parts with bolts and nuts.
- Testing of the mould on a rotational machine.

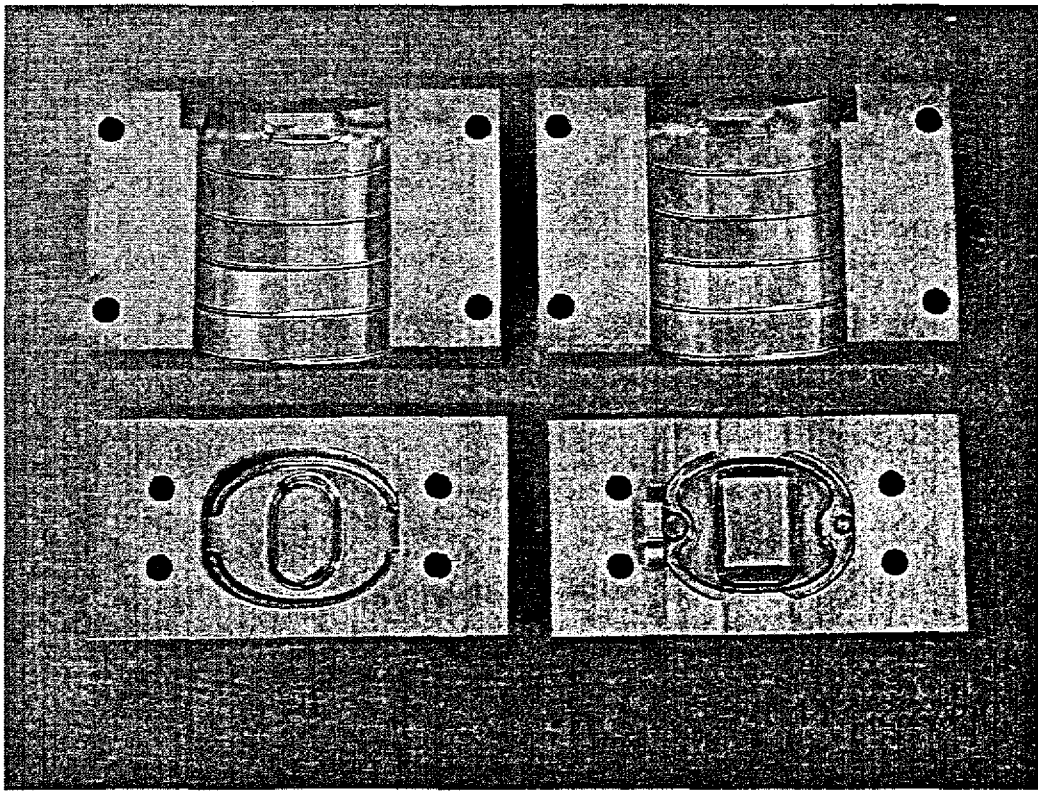

Figure 5.15. Finished rotational mould parts, product side

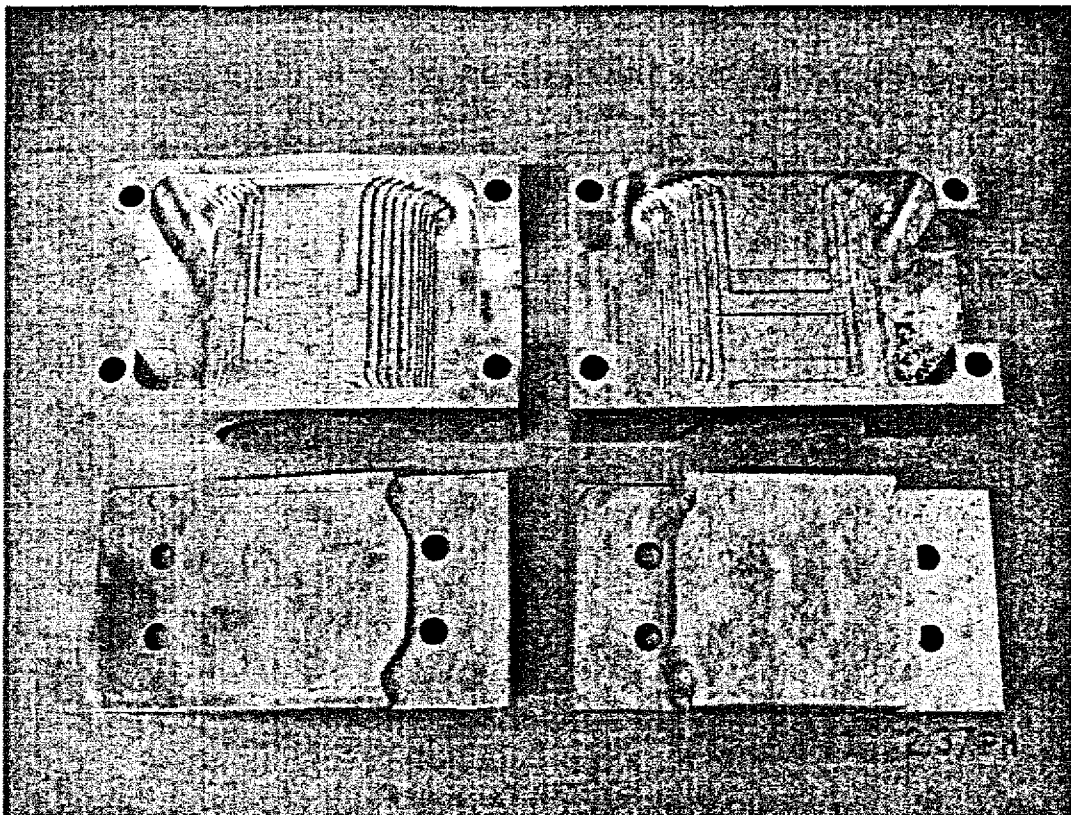

Figure 5.16. Finished rotational mould parts, reverse side

5.8. SOME PICTURES OF THE SMALL SIZE MOULD AND PRODUCTS

This small rotational mould was tested at the Atlas Plastics making a perfect product first time and thus the manufacture of this mould has been proved successful. Thus Pentech has the skills and technology to manufacture rotational moulds.

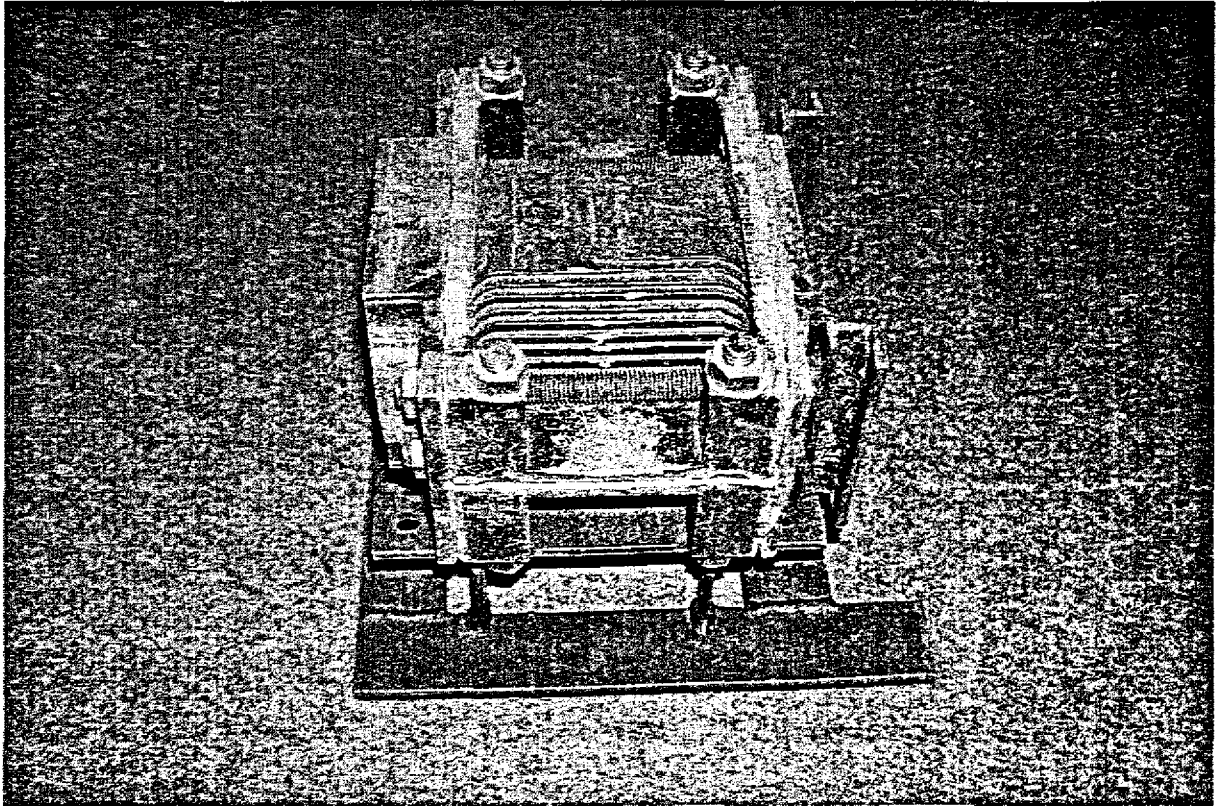

Figure 5.17. Assembled mould to be tested
(Compliments of Atlas Plastics)

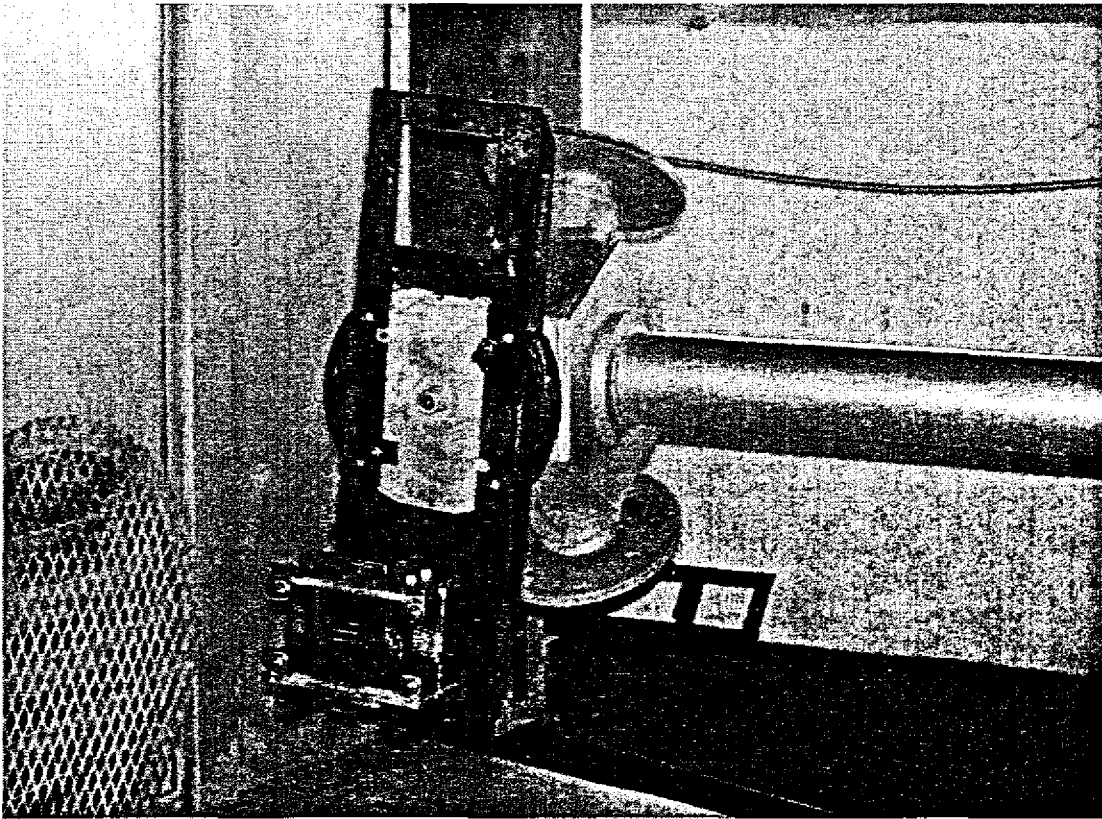

Figure 5.18. The processing of the moulding
(Compliments of Atlas Plastics)

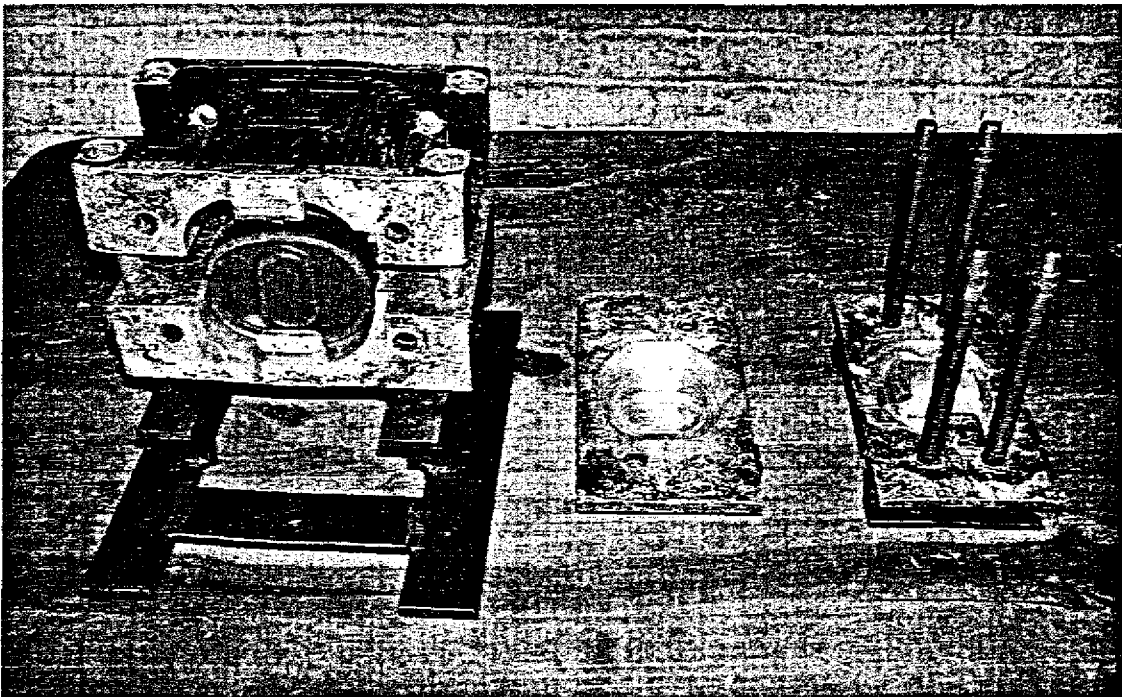

Figure 5.19. Product and mould during demoulding
(Compliments of Atlas Plastics)

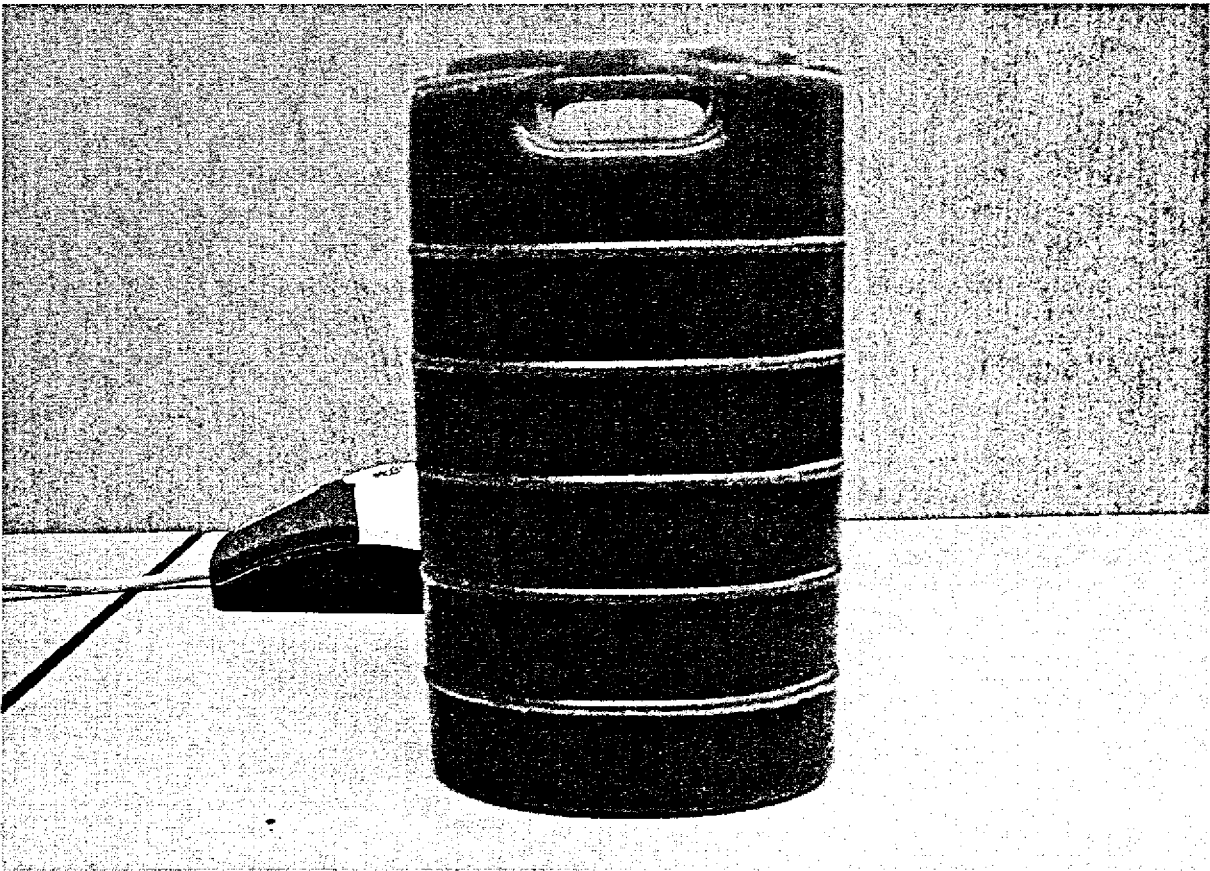

Figure 5.20. Final product of model size 220 l drum
(Compliments of Atlas Plastics)

5.9. DISCUSSION OF THIS SMALL SIZE ROTATIONAL MOULD

During the manufacturing of this small size rotational mould the following lessons were learned:

- 1) $\text{Ø}3\text{mm}$ and smaller Tungsten carbide ball nose cutters can only be used with speeds and feed of $S=5800\text{rpm}$, $F=20\sim40\text{m/min}$.
- 2) In order to get the best surface finish on aluminium, Tungsten carbide cutters should be operated at a linear tip velocity of $V=150\text{m/min}$.
- 3) With some clever design the mould flange holes can be used to attach the workpiece to the clamping frame. This removes the need for extra clamping holes. In this small rotational mould, the flange holes are designed at $\text{Ø}12\text{mm}$. Some of these holes were first tapped at M10 for clamping and then re-drilled to $\text{Ø}12\text{mm}$.
- 4) As it turns out one of the M10 holes used for attachment of the workpiece to the clamping frame ended up being under the toolpath used to separate the four mould parts. This caused complications and should be avoided if cutting multiple parts from one workpiece in the future.

- 5) If two or more mould parts are machined from one workpiece then the gap that is required between the parts should be a minimum of 22mm. So the gap can be cut with a $\text{Ø}20$ long series 3-flute slot drill. The cut must be made using a circular 2D profile toolpath because the gap distance (22mm) is wider than the diameter of the cutter (20mm). If the toolpath does not consist of a circular 2D Profile, then the material will pinch the $\text{Ø}20\text{mm}$ cutter. Pinching a cutter always leads to cutters breakage. The 2mm is needed to be able to leave a 0.5mm final cut on each part's vertical faces.

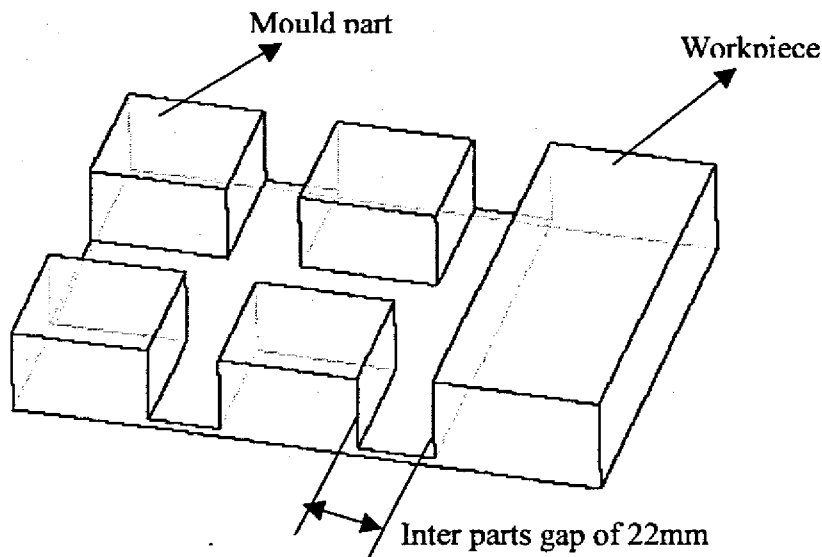

Figure 5.21. Mould part separation slots

- 6) As a general recipe for a great surface finish on aluminium the following must be observed:

1. Maximum Depth of Cut = 0.5mm, preferably 0.2mm
2. Linear cutting velocity:
 $V = 90\text{m/mm}$ for HSS,
 $V = 150\text{m/mm}$ for Tungsten Carbide.
3. Chip load $d=0.02\text{mm/rev/flute}$
4. Spindle speed S from formula $S = \frac{1000 V}{\pi D}$ [37]

Where D = cutter diameter.

If $S > 5800\text{rpm}$, then choose $S=5800\text{rpm}$. (Machine maximum spindle speed is $S6000\text{rpm}$ at Pentech)

5. Feed rate F from formula $F = dSN$,
 Where d = chip load,
 S = spindle speed to be used
 N = number of flutes (blades)
6. Step Over = 0.1mm for ball nose cutters, or = 60% for end mills/slot drills
7. Coolant must blast cutter

- 7) To prevent breakages of small diameter cutters (diameter smaller than 6mm) only tungsten carbide cutters should be used. This is because Tungsten Carbide cutters are tougher than HSS and do not easily break when cutting aluminium.
- 8) When the spindle speed formula indicates a higher spindle speed than the maximum spindle speed of the machine, then only insert type and Tungsten Carbide cutters should be used.
- 9) For rough cutting a max depth of cut of 2mm can be used safely. If the depth of cut is too big, the cutting forces also get too big and then the workpiece can be pulled from its clamping arrangement scrapping the job.
- 10) For rough cutting a maximum chip load of 0.15mm/rev/flate for aluminium has proved safe.
- 11) The surface finish produced by Seco MiniMaster cutters is not good enough for a mould cavity surface. MiniMaster inserts are not sharp enough and there is too much vibration on the slender shanks of the tool. Rather use Tungsten Carbide cutters, they give a better surface finish and are way cheaper.
- 12) In order to get shape definition on the mould cavity surfaces, a range of ball nose cutters should be used. Typically this job uses:
- | | | |
|--------|---|---|
| Ø8.0mm | } | Each time the diameter is a little more than half the previous diameter |
| Ø5.0mm | | |
| Ø3.0mm | | |
| Ø1.5mm | | |
- 13) In order to get a sharper edge at each split line, face all flanges leaving 0.2mm stock, complete the machining of all cavities and product surfaces and then lastly comeback and face off the last 0.2mm off the flanges.
- 14) It is very important to plan the entire job first with all toolpaths before the start of any machining. The planning should include setting up of all operations for all toolpaths as well. If not done this way, it will cause clamping problems and lead to unnecessary extra setup steps on the workpiece, reducing accuracy. If one solves the entire software problem first, then all clamping problems can be solved next and all machining jobs can be ordered without problems.
- 15) The type of coolant used on aluminium is important for the surface finish of the machined parts. Two coolants were used at this project, the first one being Castrol ClearEdge, which is a general coolant used for steel, copper, etc. the second one being Castrol Alusol, which is special designed for aluminium usage. The difference between these two coolants are:
- | | |
|---------------------|---|
| ClearEdge: | Leaves black oxidation mark |
| Alusol: | No marks |
| Both cost about | R500 / 20L |
| ClearEdge dilution: | 1:3 to 1:6 |
| Alusol dilution: | 1:4 to 1:10. The 1:10 dilution was used and worked very well. |

CHAPTER 6 SURFACE FINISH EXPERIMENT

During the machining of the small size rotational mould it was realized that the cutter type seemed to be one of the deciding factors in finish surface quality. One got the sense that Tungsten Carbide seemed to be the best. A recipe had also been developed for the settings to be used in the toolpaths, this needed to be qualified a bit more rigorously. A surface finish experiment was then decided upon and additional cutter types were investigated to be included in the experiments. That is when the YG X-Power and YG Alu-Power cutters were discovered.

6.1. THE CUTTERS USED FOR THE EXPERIMENT

There are five different cutters types chosen for this experiment. In each cutter type a Ø8mm ball nose cutter will be used for the surface test and a Ø10mm slot drill for pocket test. A separate test part will be used for each cutter type. The cutters are listed below:

1.	YG X-Power Ø8mm	ball nose	for surface test
	YG X-Power Ø10mm	slot drill	for pocket test
2.	Seco MiniMaster Ø8mm	ball nose	for surface test
	Seco MiniMaster Ø10mm	slot drill	for pocket test
3.	YG Alu-Power Ø8mm	ball nose	for surface test
	YG Alu-Power Ø10mm	slot drill	for pocket test
4.	Tungsten Carbide Ø8mm	ball nose	for surface test
	Tungsten Carbide Ø10mm	slot drill	for pocket test
5.	Seco Spade Ball nose Ø8mm	ball nose	for surface test
	Seco Nano Turbo Ø10mm	Turbo mill	for pocket test

6.2. THE TEST PARTS

The test part is designed using SolidWorks 2001 Plus and the workpiece size is 100mm x 100mm x 25mm. The left side of the test part represents a typical cavity surface, which will be machined by ball nose cutter during the experiment. The right side of the test part is a pocket, which will be machined by slot drill cutter. The right side pocket has two test surfaces, namely the flat bottom and the four sidewalls of the pocket.

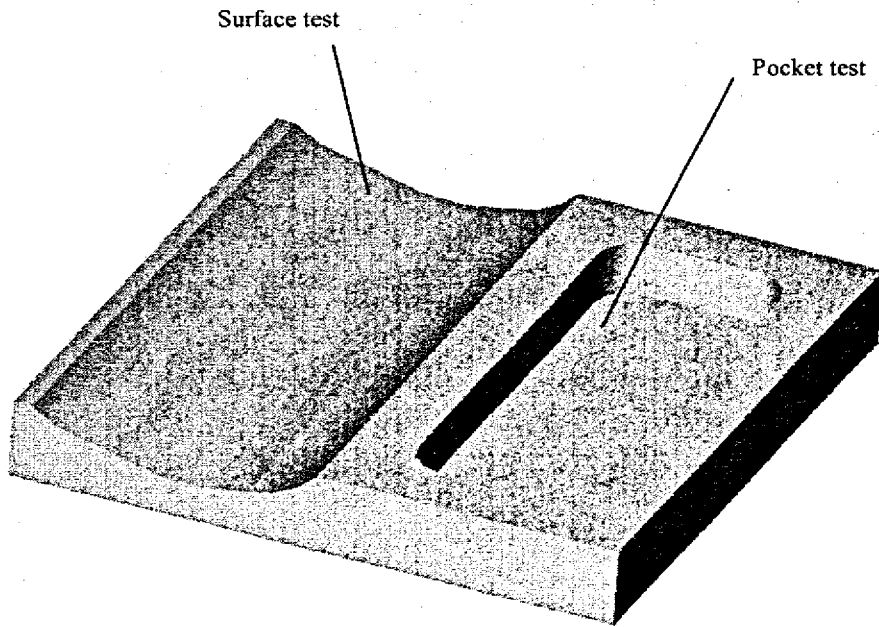

Figure 6.1. CAD model of the test part

6.3. TOOLPATH NC PROGRAMS USING EDGE CAM

EdgeCAM 5.75 was used to develop the toolpaths and generate NC files for these test parts. At the rough cutting stage, the same roughing NC program, with a Seco Turbo Mill Ø16mm is used for all the five test parts. At the semi-finishing stage, the five test parts share two NC programs, a HSS Ø8mm ball nose program for the surface test area and a HSS Ø12mm slot drill program for pocket. At the last stage, all the different cutters use different NC programs according to their different cutting parameters, including spindle speed, feedrate and plunge rate.

Table 6.1 The common parameters for all 5 of the ball nose cutters:

Surface machine	Cutting increment	Step over	Offset	Tolerance
Rough	0.8mm	50%	0.8mm	0.02
Semi-finish	N/A	10%	0.2mm	0.02
Finish	N/A	2%	0.0	0.01

The common parameter for all the slot drill cutters when cutting pocket

Pocket	Cutting increment	Step over	Offset	Tolerance
Rough	2.0mm	50%	0.8mm	0.02
Semi-finish	8.0mm	N/A	0.2mm	0.02
Finish	8.0mm	N/A	0.0	0.01

Table 6.2 The feedrate and spindle speed of these five brand cutters:

	Lin. Tip Velocity (m/min)	Spindle speed (rpm)	Chip load (mm/rev/fl)	Feedrate (mm/min)	Number of Blades
X-power ball nose Ø8mm	200	5900	0.02	236	2
X-power slot drill Ø10mm	200	5900	0.02	236	2
MiniMaster Ø8mm	880	5900	0.02	236	2
MiniMaster Ø10mm	880	5900	0.02	354	3
Alu-power ball nose Ø8mm	350	5900	0.02	354	3
Alu-power slot drill Ø10mm	350	5900	0.02	236	2
Tungsten carbide ball nose Ø8mm	360	5900	0.02	236	2
Tungsten carbide slot drill Ø10mm	360	5900	0.02	236	2
Seco spade ball nose Ø8mm	800	5900	0.02	236	2
Seco Nano Turbo Ø10mm	620	5900	0.02	236	2

From the above table it is clear that even the lowest Linear Tip Velocity of any of the cutters results in a Spindle Speed higher than the machine maximum of 6000rpm and hence 5900rpm, just under maximum. This seems to be the modern trend. When using a fancy cutter type and a medium to small side cutter the Spindle Speed invariably end up at maximum. Thus for most of the cutting work the machine spindle runs flat out and spindle bearings do not last very long.

The Chip load, which largely determines the Feedrate, is always set at 0.02 for a good finish. This is a well-trying and tested recipe.

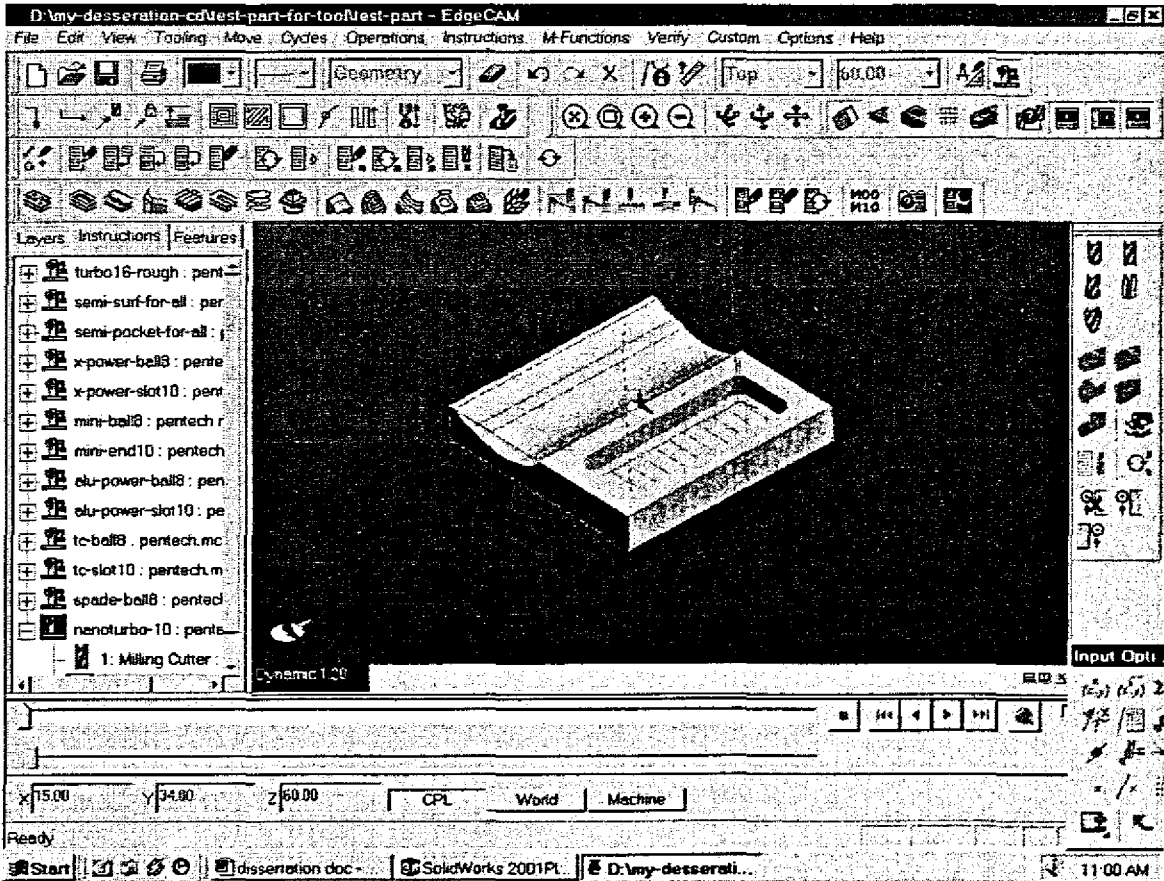

Figure 6.2. EdgeCAM toolpath generation

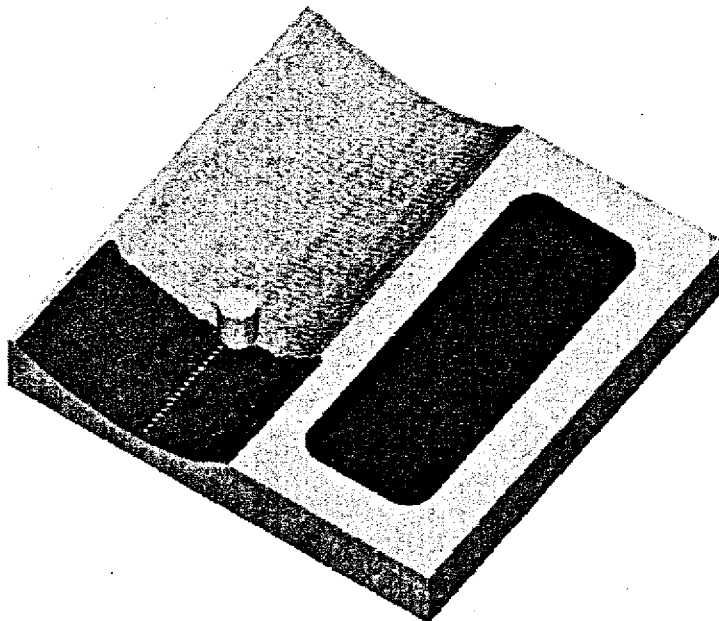

Figure 6.3. Cutting simulation in EdgeCAM

6.4. COMPARISON BETWEEN SOFTWARE SIMULATION TIME AND REAL CUTTING TIME

The software simulation time normally can't be exactly the same as the actual machining time because there are many factors that influence the actual cutting time. Firstly, software simulations will have a numeric tolerance when calculating the machining time. Secondly, the start co-ordinates of the cutter on the machine are often not the same as those set in the computer program, Thirdly, during the actual machining process, the operator may pause the machine to check for problems and to adjust the coolant flow. So minor differences between the software simulation time and the actual machining time are expected.

Table 6.3 Comparison of simulation time and actual cutting time for this experiment

	Simulation time	Actual cutting time
Roughing	2'46"	2'42"
Semi-finishing	6'29"	6'33"
X-Power cutters	2h18'8"	2h18'5"
MiniMaster cutters	2h17'26"	2h17'20"
Alu-Power cutters	1h33'11"	1h33'16"
Tungsten Carbide cutters	2h18'8"	2h18'13"
Seco Spade and Nano cutters	2h18'8"	2h18'2"

The above values are surprisingly very close

6.5. DISCUSSION OF THE EXPERIMENT RESULTS

This experiment was successful. Normal coolant was used, as the new coolant had not been delivered before the start of the experiment. The experiment results are as follows:

- 1) For the range cutters used, the simulation time and the actual cutting time are close enough to be considered the same. Good news for the quoting of jobs in the future.
- 2) In both the surface test and the pocket test Alu-Power, X-Power, and Tungsten Carbide cutters gave a very similar high quality surface finish. The big difference being that Tungsten Carbide is about half the price of the other two

cutters. This test does not give any indications of wear rates, but with the number of one-off jobs Pentech does this is not really an issue. Some of the Alu-Power cutters come with 3 flutes, giving a faster feedrate. Possibly if Pentech's machine's maximum Spindle Speed was a lot higher, then the cutters would be pushed closer to their limits showing more advantages for the more expensive cutters.

- 3) Clearly for aluminium all the Seco insert cutters do not give the desired surface finish, These cutters are, however, still the best for roughing due to their very high speeds and feeds.

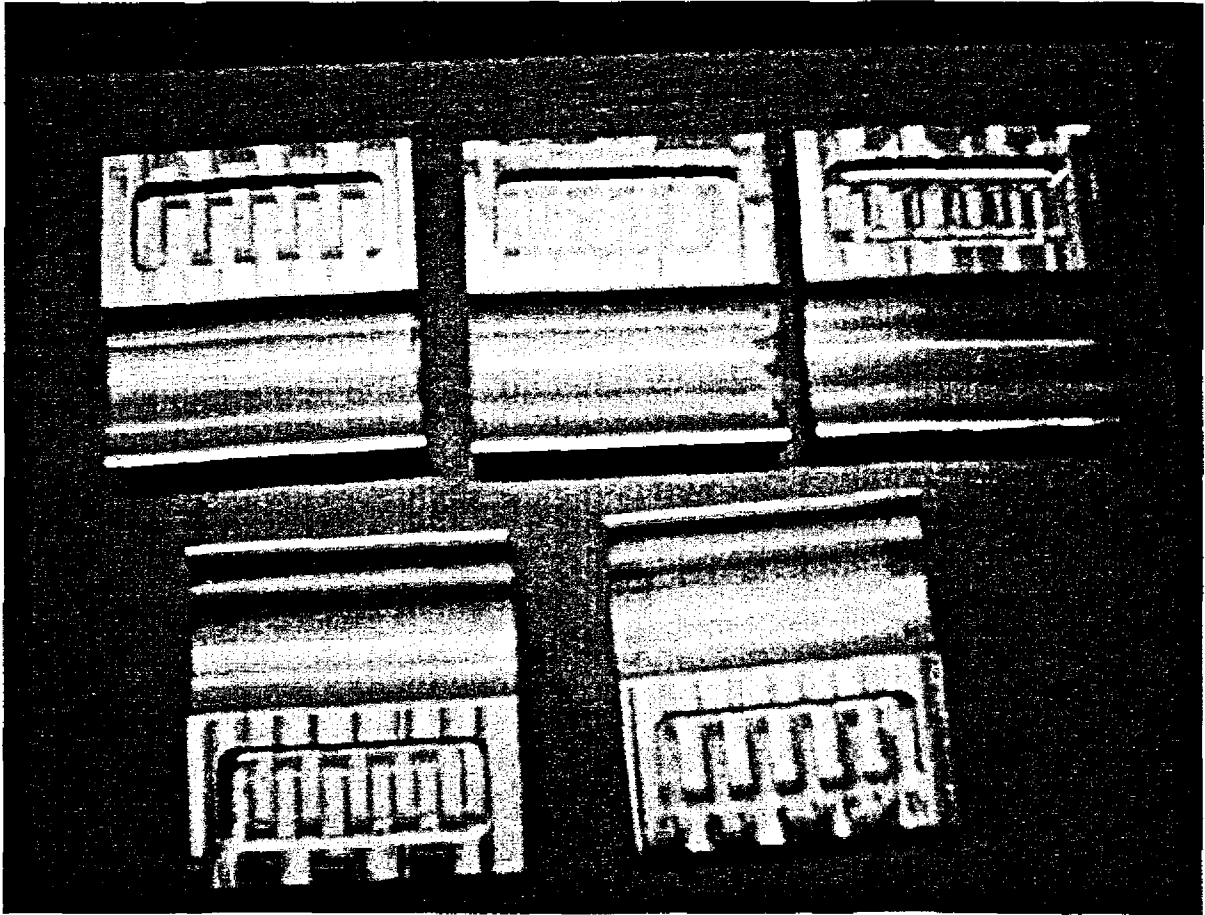

Figure 6.4. The five machined test parts

CHAPTER 7 MEDIUM SIZE ROTATIONAL MOULD

After having proved Pentech's rotational mould making ability with the small size mould, the medium size mould is now used to demonstrate the advantages of mould half subdivision. The product used for this part of the study is a steering wheel.

Both halves of the medium size steering wheel mould will use a boss insert type subdivision. It will be shown how making use of these insert parts will dramatically reduced the mould workpiece size and also has reduced the machining time significantly. It also strengthened the theory in this research proposal that a big size rotational mould can be split into a number of small segments, and then be manufactured on medium size CNC machines.

7.1. WORKPIECES

If the mould halves were to be made from single workpieces the size would be:

Plate workpiece for mould top half 380 x 380 x 50mm

Plate workpiece for mould lower half 380 x 380 x 120mm

After the subdivision with the boss insert type parts, the workpiece sizes are:

Plate workpiece for mould top half 380 x 380 x 20mm

Plate workpiece for mould lower half 380 x 380 x 60mm

Round Bar Stock of smaller insert $\text{Ø}50 \times 37$ long

Round Bar Stock of bigger insert $\text{Ø}160 \times 70$ long

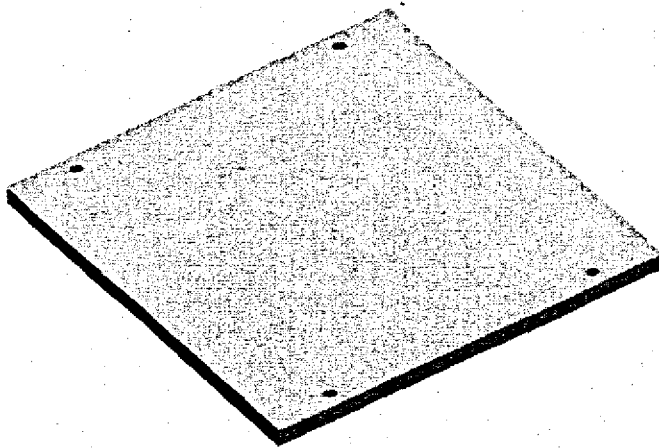

Figure 7.1. Workpiece for mould topside

7.2. CLAMPING FRAME

Once again the same clamping frame arrangement will be use as with the small size mould. Once again made from mild steel 40 x 40 x 2.5 mm square tubing.

The frame size is: 500mm x 380 x 40mm

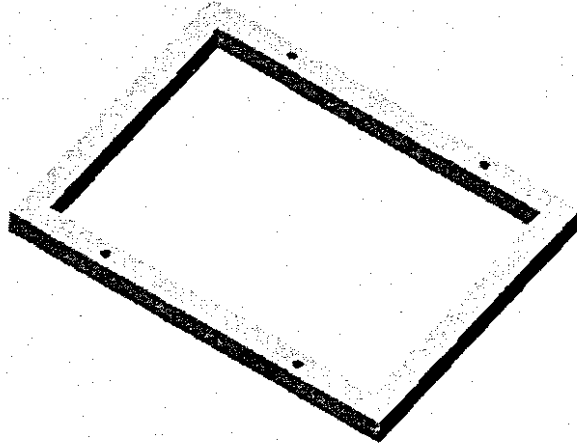

Figure 7.2. Mild Steel clamping frame

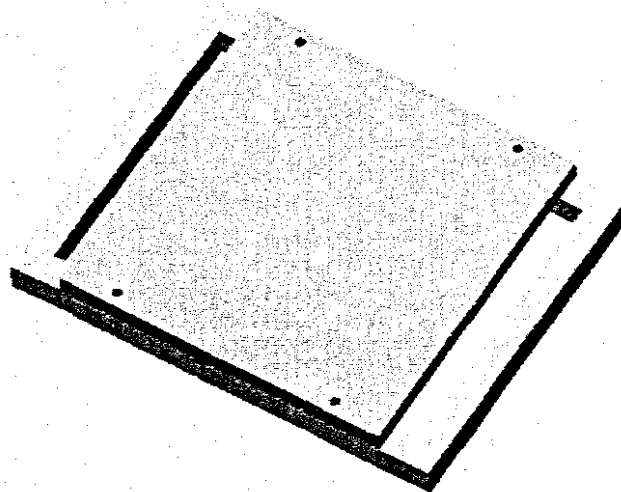

Figure 7.3. Workpiece bolted to clamping frame

7.3. THE CAD DESIGNED PRODUCT

The product of this medium size rotational mould is steering wheel, which was supplied by Atlas Plastics, the project partner. Because of version incompatibilities, it was decided that the fastest way to proceed was to redraw the product from the eDrawings image that was accessible. This is one of the big disadvantages of the SolidWorks software; they purposefully do not allow backwards compatibility of CAD model files. The educational versions seem to come out a lot later than the commercial versions, making Pentech's collaboration with industry difficult.



Figure 7.4. Steering wheel, front-side view in SolidWorks
(Compliments of Atlas Plastics)

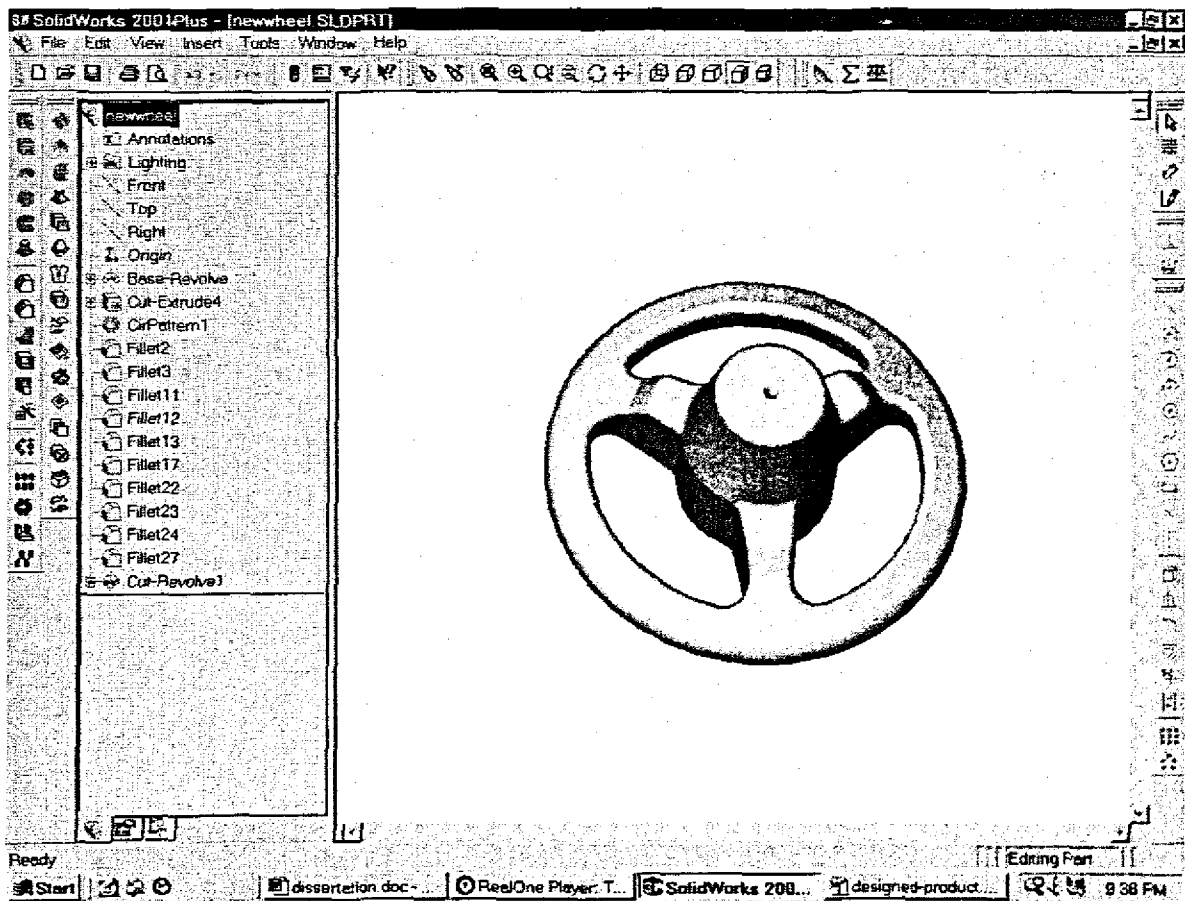

Figure 7.5. Steering wheel, reverse side view in SolidWorks
(Compliments of Atlas Plastics)

7.4. THE DESIGN OF THIS MEDIUM SIZE STEERING WHEEL ROTATIONAL MOULD

This rotational mould was first modelled the traditional way with two halves. The central boss features were then converted to insert parts. Notice the cyan coloured and the purple coloured part in figure 7.6.

Notice also that these parts are largely cylindrical or rather typical CNC lathe parts. As Pentech does not own a CNC lathe, here was an ideal opportunity to put the concurrent subcontracting idea of this work into practice. This project made use of the CNC lathe at the Bellville Technical College, another opportunity for first time collaboration.

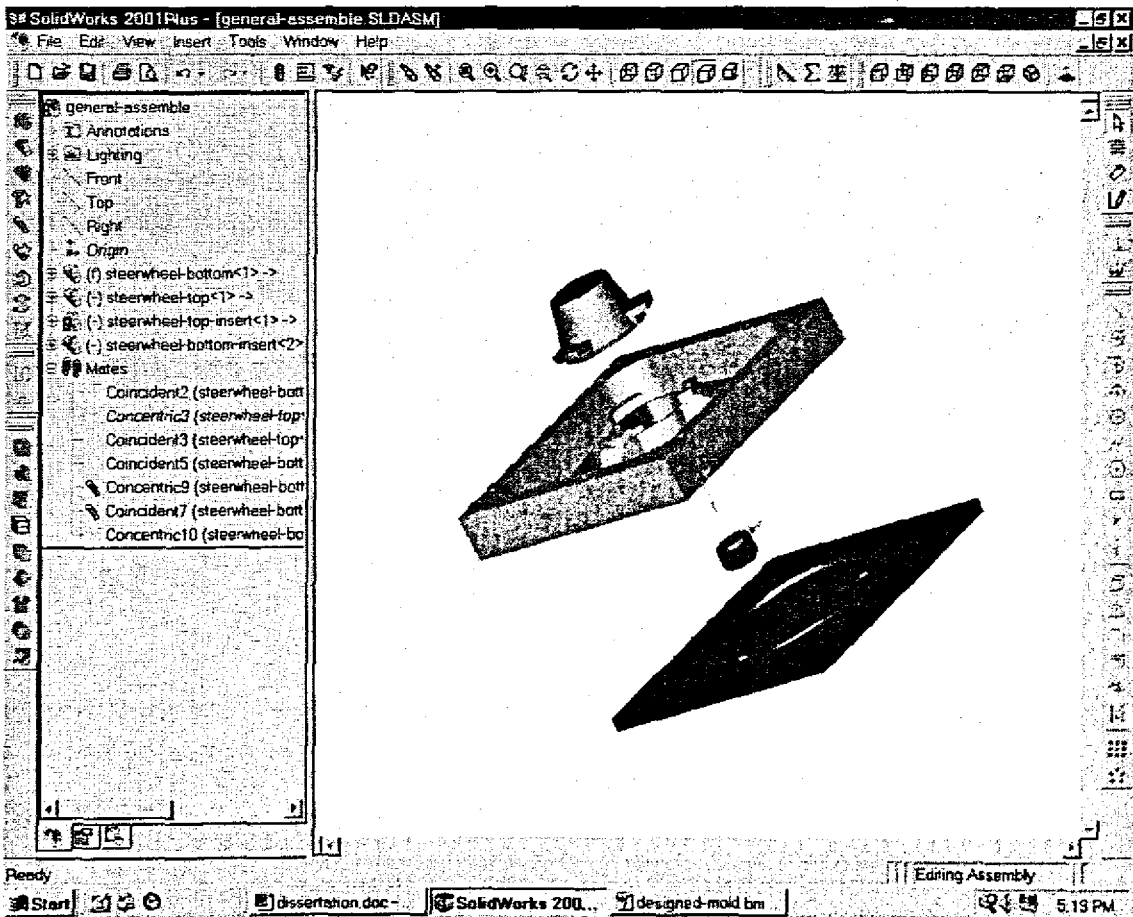

Figure 7.6. Rotational mould for steering wheel, exploded view

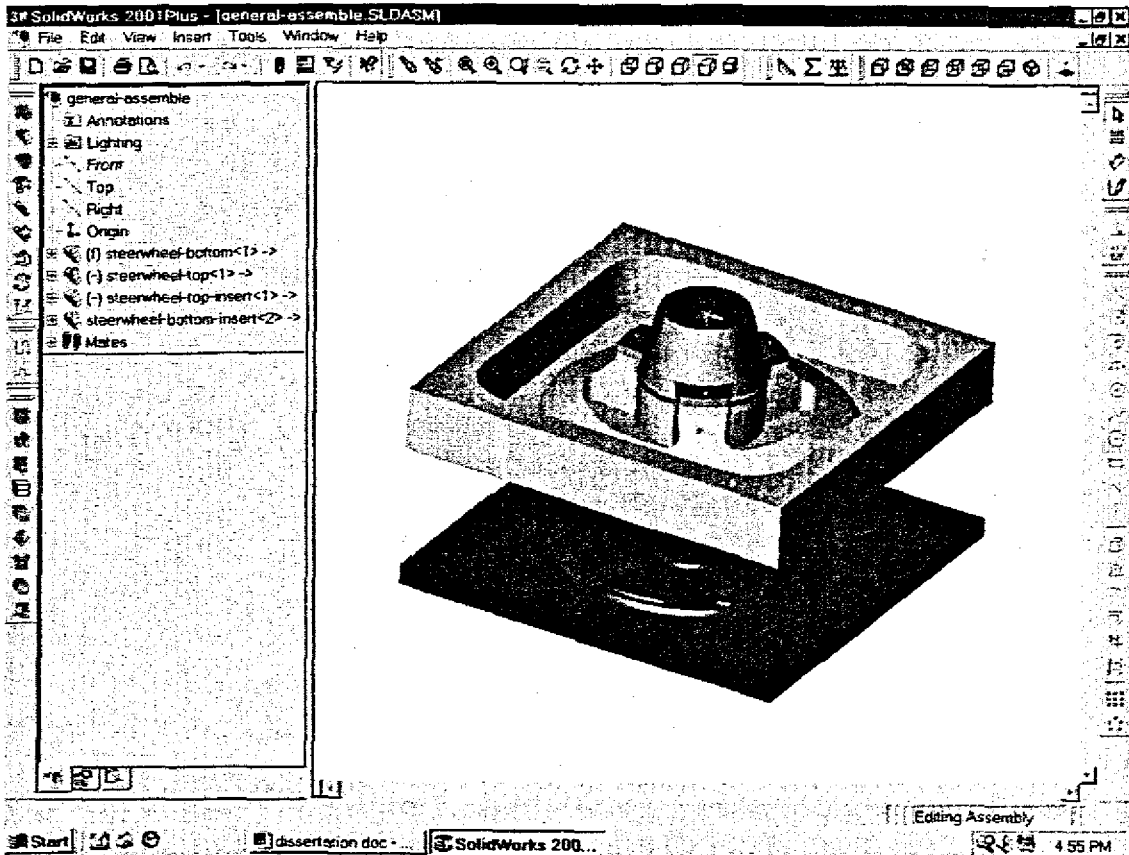

Figure 7.7. Rotational mould for steering wheel, assembled view

7.5. CALCULATION OF THE CLAMPING FORCE.

It was a concern as to whether the clamping frame concept used in this work provided sufficient clamping strength, especially when four M10 cap screws are being used.

The calculation for this solution is:

Cutting forces and power:

Bolts are mainly subject in the shear stress, the formula for the shear stress is:

$$\tau = \frac{F}{A}, \quad [13]$$

Where, F , the cutting force in XY plan
 A , the section areas of the bolt
 τ , the allowable shear stress

The M10 cap screws were bought as Grade 8.8 bolts. From Drotsky Table 9.1 [9] tensile proof load for M10 is 33.7kN and bolt section area $A = 58.0 \text{ mm}^2$.

The shear yield load would be given by

$$\begin{aligned} S_{sy} &= 0.577 S_{yt} & [9] \\ &= 0.577 \times 33.7\text{kN per bolt} \\ &= 19.4\text{kN} \end{aligned}$$

From Drotsky paragraph 9.7 the recommended Factor of Safety $S = 2.5$

For 4 bolts the allowable shear yield load would be given by

$$\begin{aligned} F &= 4 S_{sy} / S \\ &= 4 \times 19.4\text{kN} / 2.5 \\ &= 31.0\text{kN} \end{aligned}$$

The maximum machine cutting force:

$$P = F V \quad [13]$$

Where: P is the machine maximum cutting power.

From the Eumach catalog [10] $P = 9.0\text{kW}$.

V is the Linear Tip Velocity for aluminium

See appendix C, $V = 150\text{m/min} = 150 / 60\text{m/s}$

$$\begin{aligned} \text{Thus } F &= \frac{P}{V} \\ &= 9000\text{W} / (150 / 60)\text{m/s} \\ &= 3.6 \text{ kN} \end{aligned}$$

The maximum machine cutting force of 3.6kN is smaller than the allowable shear yield load of 31.0kN, thus the clamping bolts more than sufficient strength.

7.6. MANUFACTURING OF THE SMALLER INSERT PART.

The smaller insert part belongs to the top half of the rotational mould, see figure 7.8. The NC codes for this part can be generated by EdgeCAM, but since its profile was so simple, it was programmed manually.

The shape of the insert part is as below:

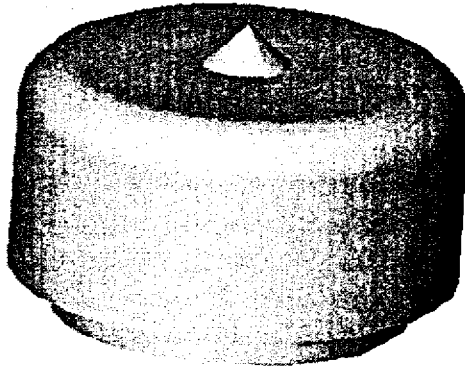

Figure 7.8. CAD model of smaller insert part

The following is the manual NC program on a Fanuc 16T controller for this insert part:

```
O0001
G28 U0. W0.
G50 S2000
G0. X100. Z100.
T0300
G96 S180 M3
G0 X70. Z10. T0303
G1 X61. Z0. F0.1
X-1.
X70.
G71 U3.0 R1.
G71 P100 Q200 U1. W0.5. F0.1
N100 X0. Z0.
W-5. U10.
X38.
G3 X50. Z11. R6.
W-27.
N200 X70.
G70 P100 Q200 S230
G0 X100. Z100.
T0200 (SLOT TOOL)
```

```
G97 S1600 M3
G0 X70. Z-37. T0202
G1 X40.
X70.
G0 X100. Z100.
T0700 (PARTING TOOL)
G96 S180 M3
G0 X70. Z-42. T0707
G1 X-0.5 F0.1
G0 X50. Z100.
M30
%
```

7.7. MANUFACTURING OF THE BIGGER INSERT PART

The bigger insert part belongs to the lower half of the rotational mould, see figure 7.9. The basic shape gets CNC turned first, and then the remaining features are CNC milled after that. The workpiece length was planned 40mm longer than the insert part's original design length. The extra 40mm length is to be used for clamping of the workpiece both during CNC turning as well as during CNC milling.

The outside and inside profiles of the part will be CNC turned, while the three ears, the three fillet surfaces as well as three holes will be CNC milled.

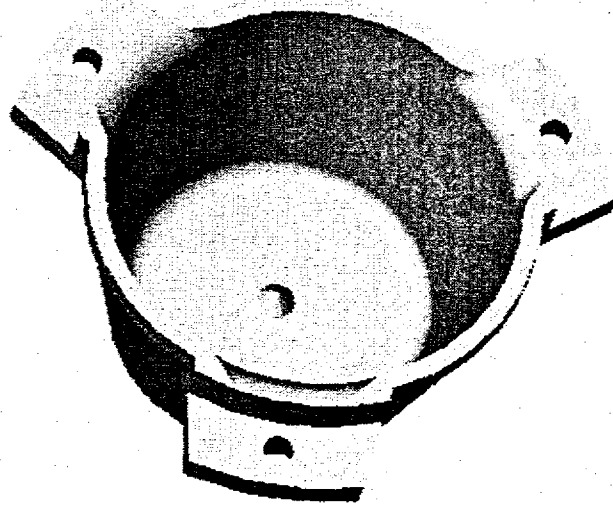

Figure 7.9. CAD model of bigger insert part, product side

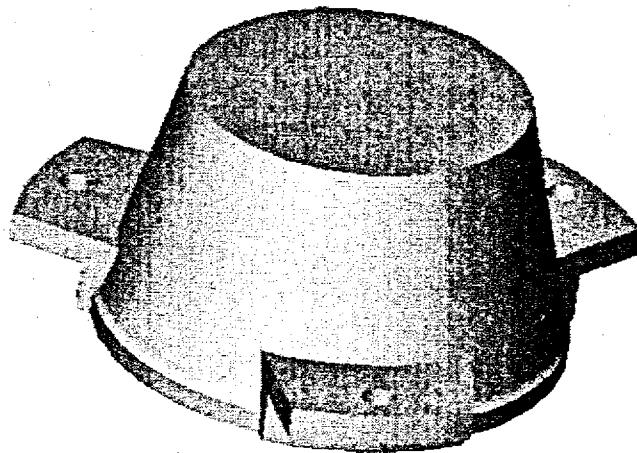

Figure 7.10. CAD model of bigger insert part, reverse side

7.8. CNC TURNING TOOLPATH PROGRAMMING OF THE BIGGER INSERT PART

The CNC turning of this part has three steps

Step 1:

Machine the shoulder, see figure 7.11.

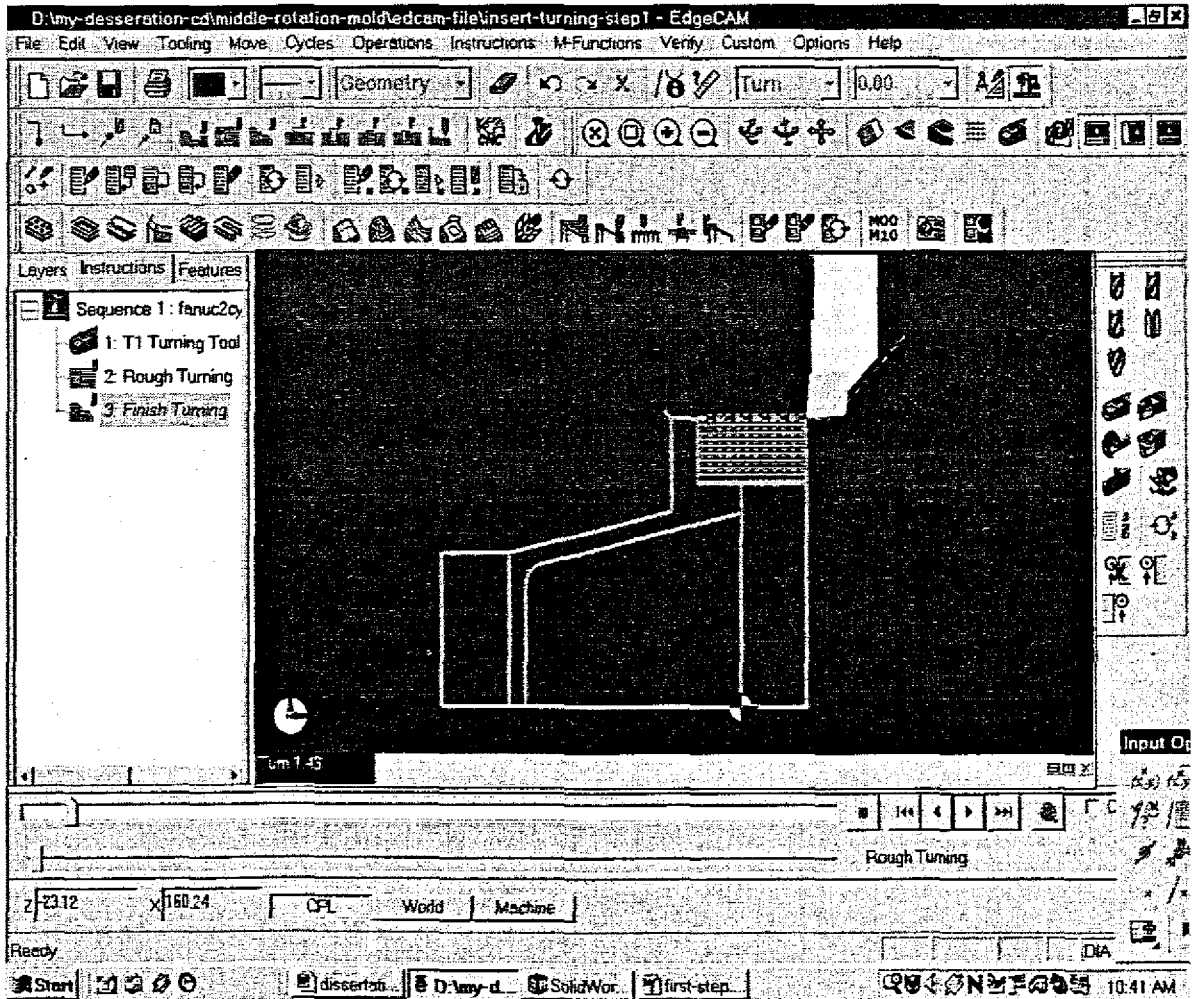

Figure 7.11. EdgeCAM programming of first turning step

Step 2:

Machine the external tapered section, see figure 7.12. The NC program for this step combines roughing and finishing cutting together, in which 0.2mm stock is left for finishing.

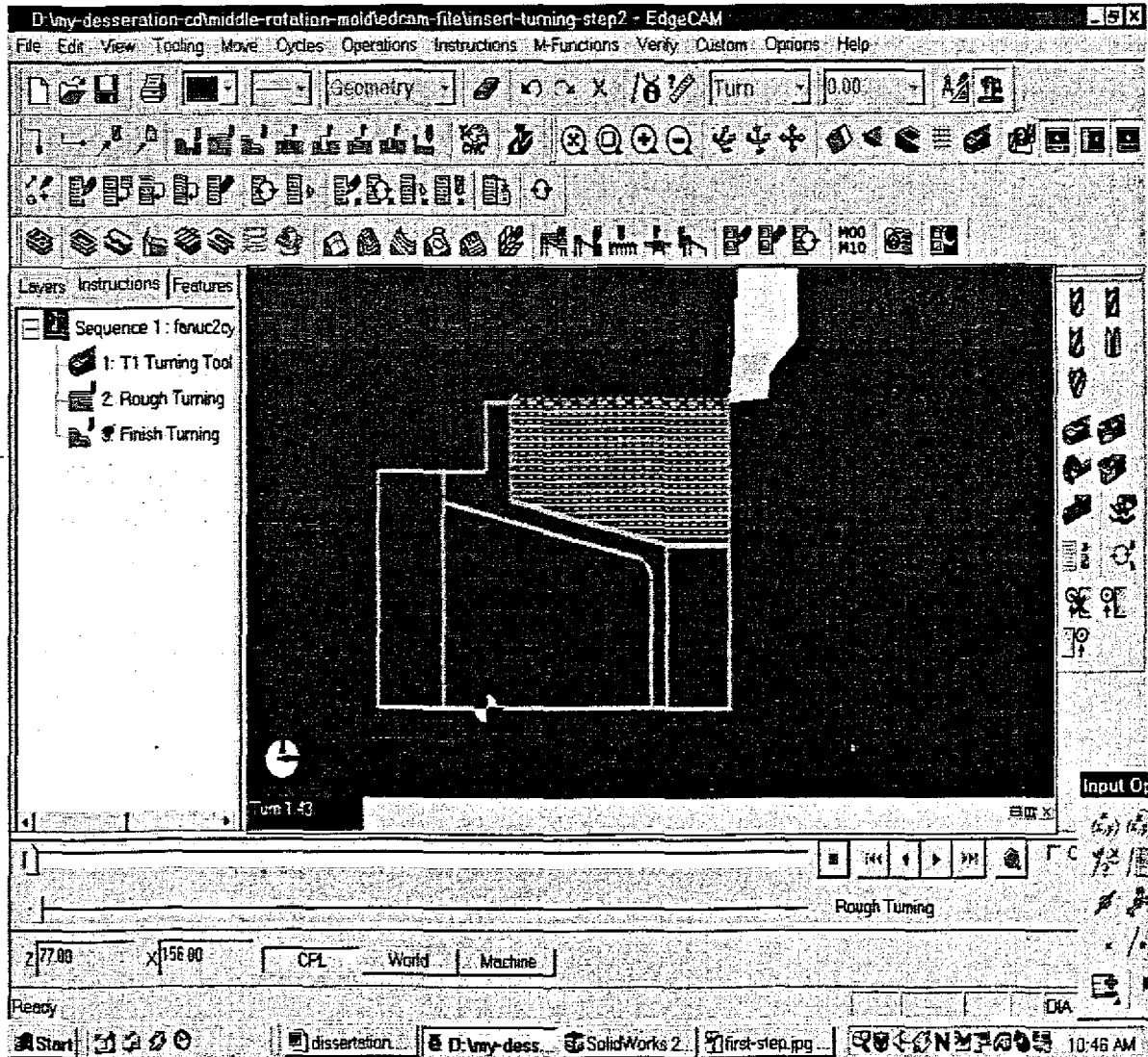

Figure 7.12. EdgeCAM programming of second turning step

Step 3:

Bore the internal taper, see figure 7.13. This surface is a product surface demanding an excellent surface finish. First a $\text{Ø}25\text{mm}$ hole was drilled to give access to the boring bar, then again both roughing and finishing cycles were employed with a machining allowance of 0.15mm for finishing.

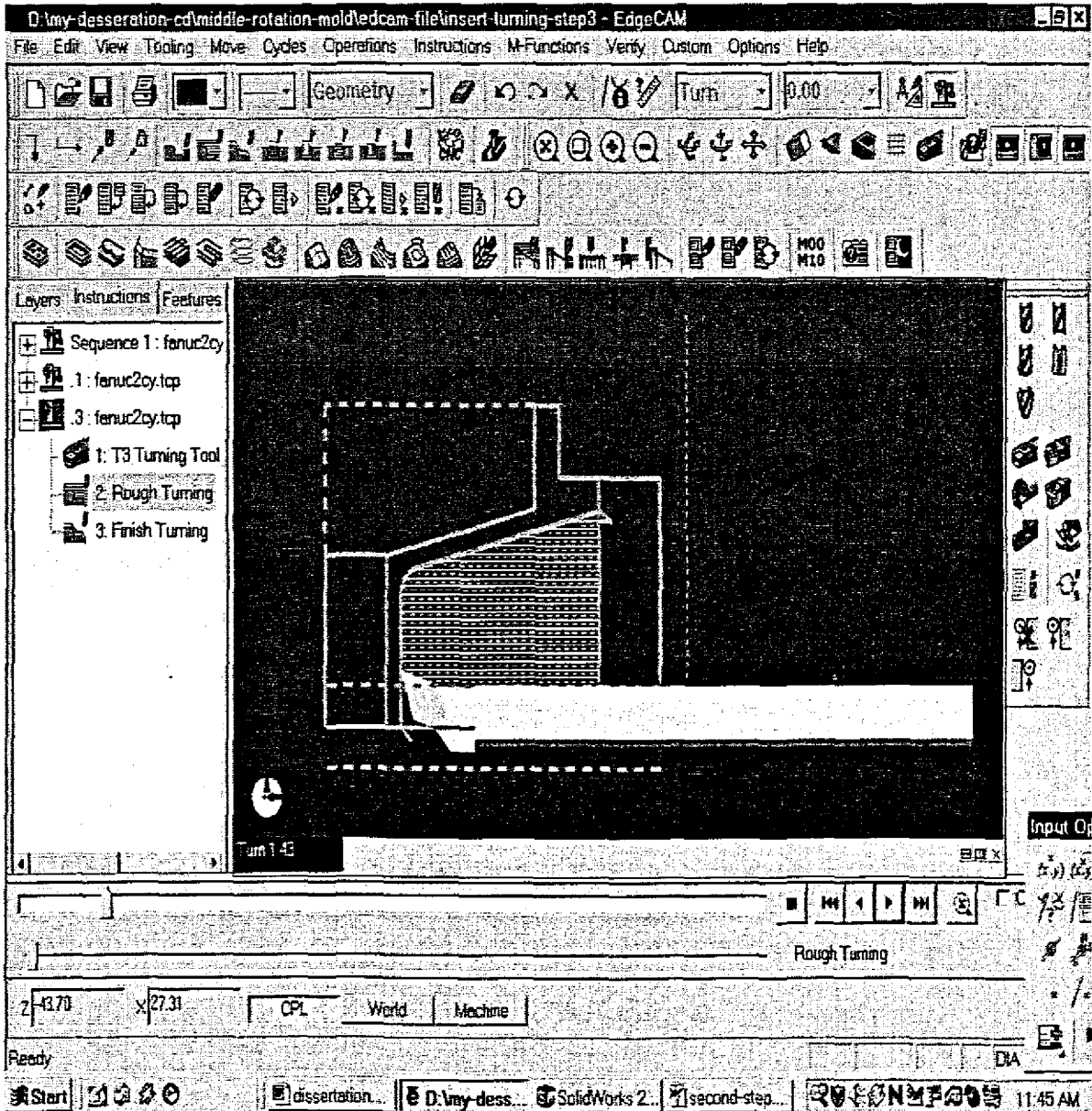

Figure 7.13. EdgeCAM programming of third turning step

A very pleasing result was obtained at the end of CNC turning.

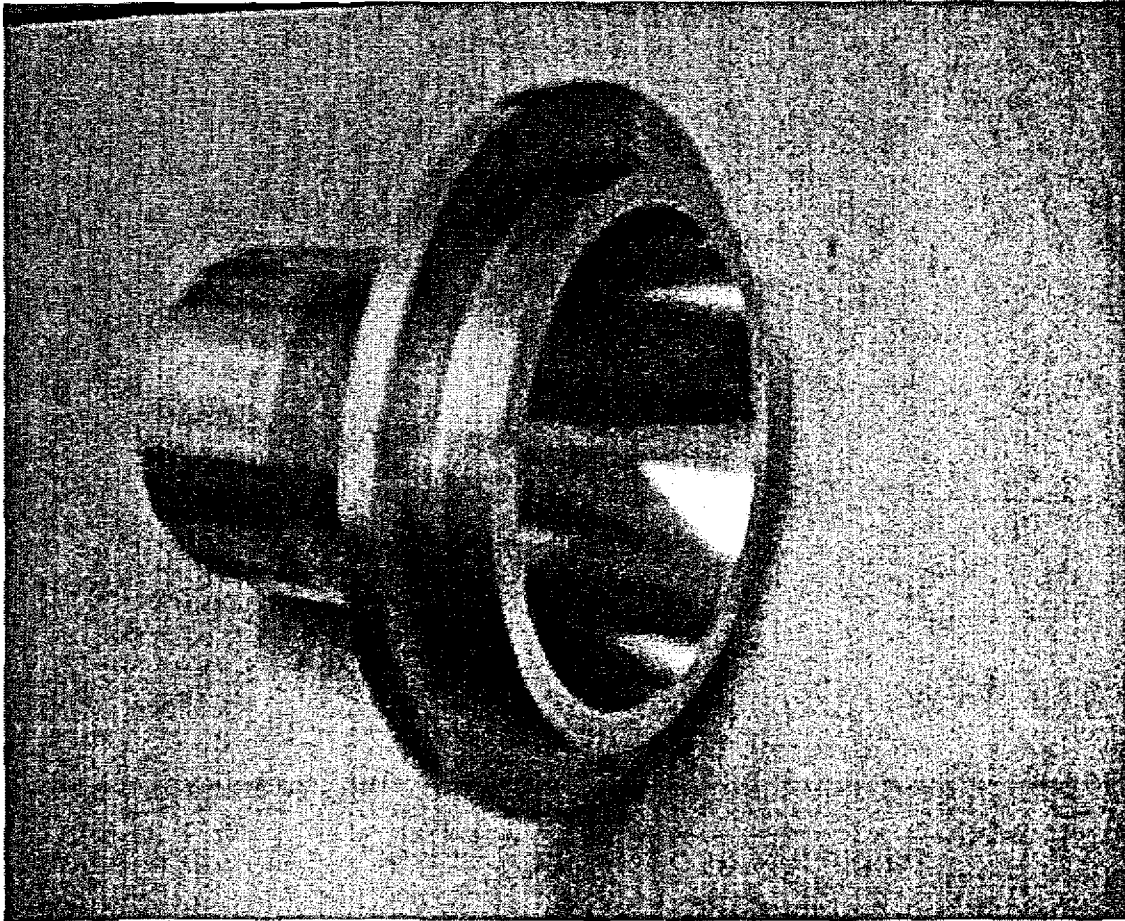

Figure 7.14. The bigger insert part after completion of CNC turning

7.9. CNC MILLING TOOLPATH PROGRAMMING OF THE BIGGER INSERT PART

There are two NC milling programs for this part, one for machining the three fillet surfaces, and another to machine the spaces between the three ears. The setup of the job on the milling machine is very important. The central axis of the part must be very accurately clocked or else the fillet tangents will not blend into the internal tapered section.

The part is clamped in the machine vice facing as shown in figure 7.15 and clocked with a finger clock of accuracy 0.002mm or 2 micron per division.

After the two NC milling programs were run the part was flipped and the remaining 40mm clamping allowance simply faced off.

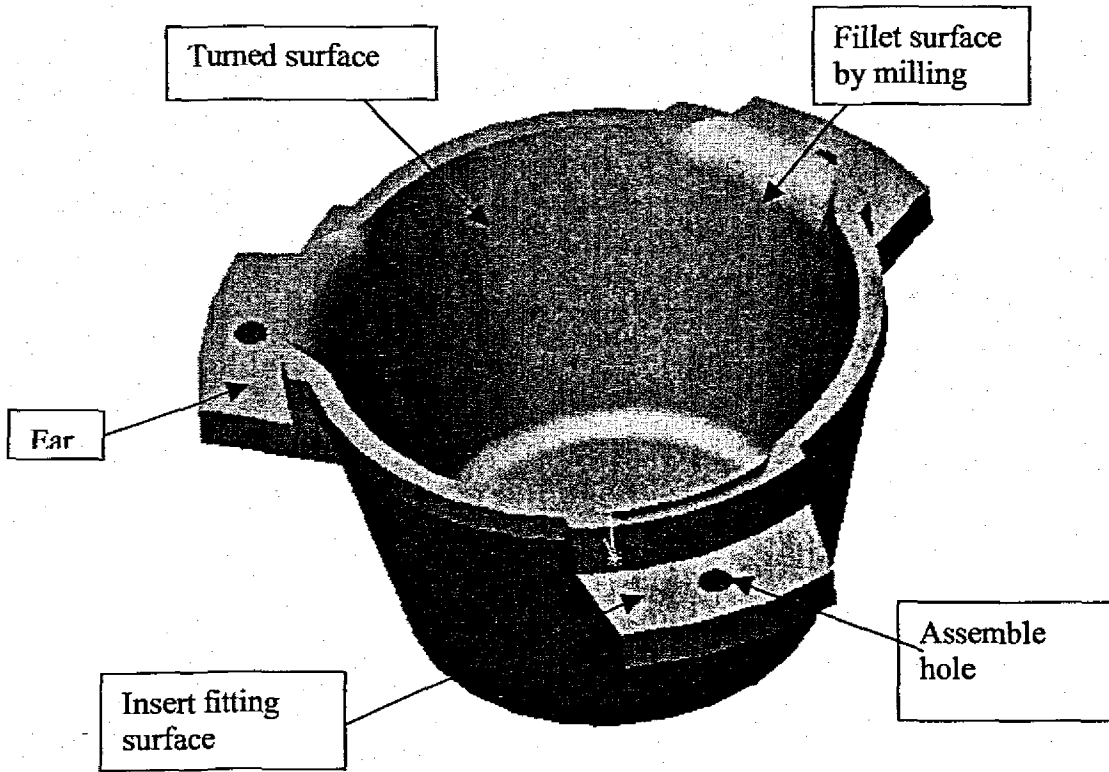

Figure 7.15. Bigger insert part for CNC milling

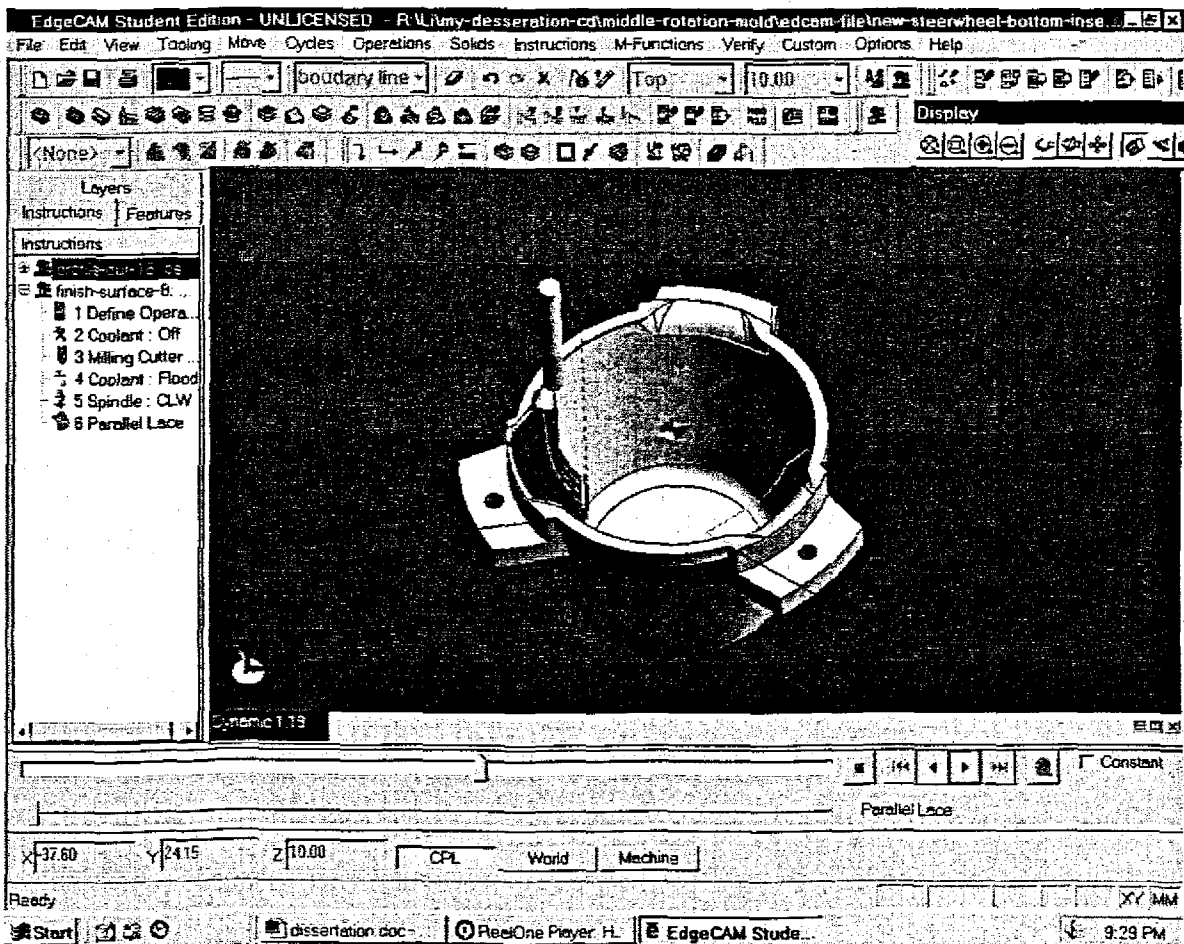

Figure 7.16. CNC milling toolpaths for the 3 fillets of bigger insert part

7.10. THE TOP MOULD PLATE

The dimensions for this top plate are 380 x 380 x 18mm. The strategy for this part is to machine the product side completely finished and then to machine the reverse side.

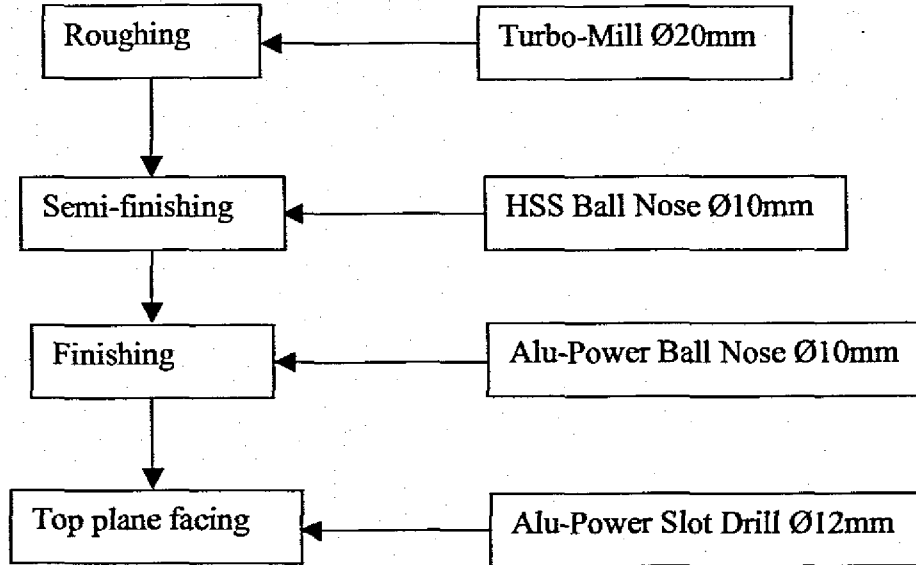

Figure 7.17. Product side cutting flow with required cutter types

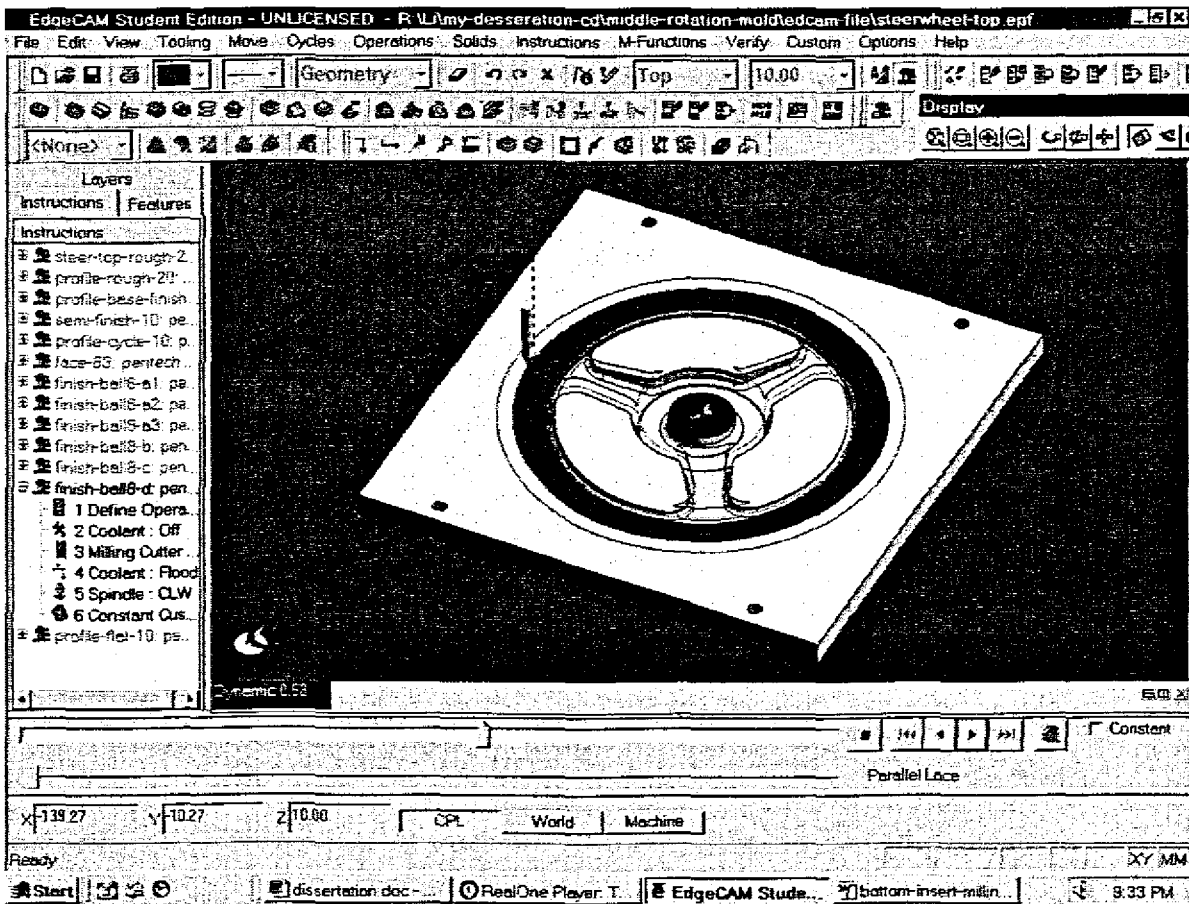

Figure 7.18. Toolpath programming for the top mould plate, product side

After the product side machining was completed, some scalloping was evident along the fillet radii of the steering wheel spokes. It was decided that this would be an ideal opportunity to test the theory that many undesirable machining marks can be polished out manually. In order that polishing ability did not influence the out come of this test, the job was subcontracted to experts in this field. Mr. Erich Essman of Speedwell Engineering in Stikland, Cape Town was contacted and the job cost R. The test was largely successful but there is still some very minor evidence of the scalloping so it was concluded that it is always preferable to remove undesirable machining marks by altering the finishing toolpath and giving an extra cut.

Next the workpiece was re-clamped on the other side and the reverse side was machined. This side uses only one roughing NC program since the rough stepped finish is 100% desirable heat transfer to the moulded surface.

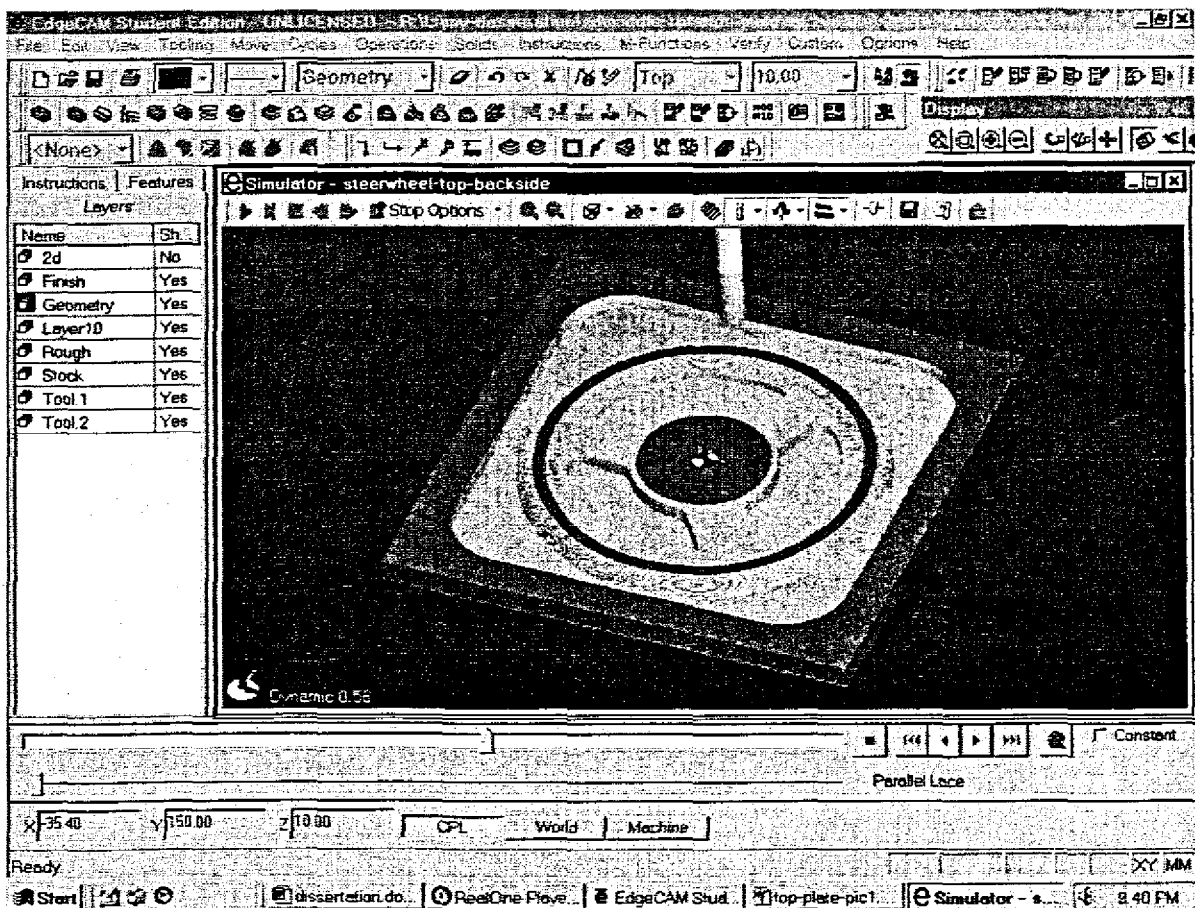

Figure 7.19. Simulation of the reverse side roughing of the top mould plate

In the new version of EdgeCAM i.e. Version 8.75 the simulation time is far more easily available. One does not have to run the whole simulation to get it, it appears in a box on screen as soon as the toolpath has been generated. This ready availability of the simulation time helps a lot with the estimation of the total cost of the parts as well as the planning of the actual cutting of the jobs on the CNC machine. Also the improved simulation function provided better visuals to see any unsatisfactory or unsafe cutting.

Table 7.1 Simulation time versus Actual cutting time for the top part:

	Roughing	Semi-finishing	Finishing	Total
Product side simulation time	1h11min	25min52sec	4h34min	6h10min52sec
Product side actual cutting time	1h20min	26min3sec	4h54min	6h40min3sec
Reverse side simulation time	1h56min24sec	N/A	N/A	1h56min24sec
Reverse side actual cutting time	1h59min	N/A	N/A	1h59min

The difference between the simulation time and actual cutting time is mainly as a result of the following:

1. The start point of the cutter in the software is different in reality. The cutter start point in the software is set at X0. Y0. Z200. In reality the cutter can be started at any point.
2. The software calculation tolerances can bring in small differences to the simulation times.
3. During the machining, the operator may pause the machine, and check the cutting quality or adjust the coolant flow. This will lengthen the cutting time in an unpredictable way.

7.11. THE PRODUCT SIDE OF THE LOWER MOULD PLATE

The lower plate of this medium size mould is the most important and difficult part to machine. Firstly it is the biggest part in this mould, so it needs more NC programming and machining time. Secondly, the cavity of this part is much deeper than the top plate, so it needs a special longer ball nose cutter to achieve the finishing cut, and because it is a longer cutter, so a slower feedrate is needed in comparison to the normal length cutter in order to reduce the cutting vibration to the minimum. Thirdly, the central hole on the reverse side of the part where the insert part fits needs a tight tolerance on a dimension of $\text{Ø}60.5\text{mm}$.

The machine procedure for this part is:

First product side: Roughing → semi-finishing → finishing

Second reverse side: Roughing → finishing (for Ø60.5mm dimension only)

The cutters used for this part:

Turbo Mill Ø20mm	for roughing of both sides
Alu-Power Ø8mm	for finishing on the product side
Alu-Power Ø12mm	for top facing
Alu-Power Ø10mm	for reverse side 2D profile on central hole

The NC finishing programs consist of three small separated surface operations. After machining a problem occurred that there is some lead in and lead out marks at the boundary of the three NC programs. Further more, the filleted surfaces at the part bottom are not as good as expected. So an extra manual polish job is need in this case in order to get a smooth and shinning cavity surface. An investigation for the surface-programming lead-in and lead-out will be carried at the next stage.

The finishing operation for the product side of the part was run three times over in order to get an acceptable surface finish.

1. During the first finishing run, the cavity surfaces were divided to three different areas, and three different small NC programs were used to machine the cavity surfaces. The advantage of using small programs is that EdgeCAM has a short toolpath calculation time. In some cases, if the part is very big and the entire cavity surfaces are put under one NC program then it will take more than one hour to calculate the toolpath. If the toolpath is not satisfactory, then it will take another hour or so to re-calculate the toolpath. So, based on this practical experience, at the first attempt, three NC programs were used. But after the machining, the cavity surfaces have some lead-in and lead-out marks at the boundary of the three NC programs. Further more, the filleted surfaces at the bottom of the part are not as good as expected. If the cavity surfaces were not to be manually polished, then this surface finish is not acceptable. Already learned from the machining and manual polishing of the top plate that it is better to machine marks out than try and polish then out. Thus a quick experiment was setup to get the best setting and solve the lead-in, lead-out mark problem. See section 7.12.
2. During the second attempt after the lead-in / lead-out experiment, a one-program strategy was used to machine the cavity. But because the cutting tolerance in the toolpath settings was set to 0.05mm and cusp height maximum was not set, the finished cavity surfaces were rougher than the first attempt although the lead-in / lead-out marks had vanished.
3. Third time lucky, the cavity surface finish was good. This time a one-program strategy was again used. The tolerance was set to 0.01mm, and the maximum cusp height was set to 0.01mm. The software calculation time for this toolpath is 50 minutes and the code generation time for the NC program is 30 minutes.

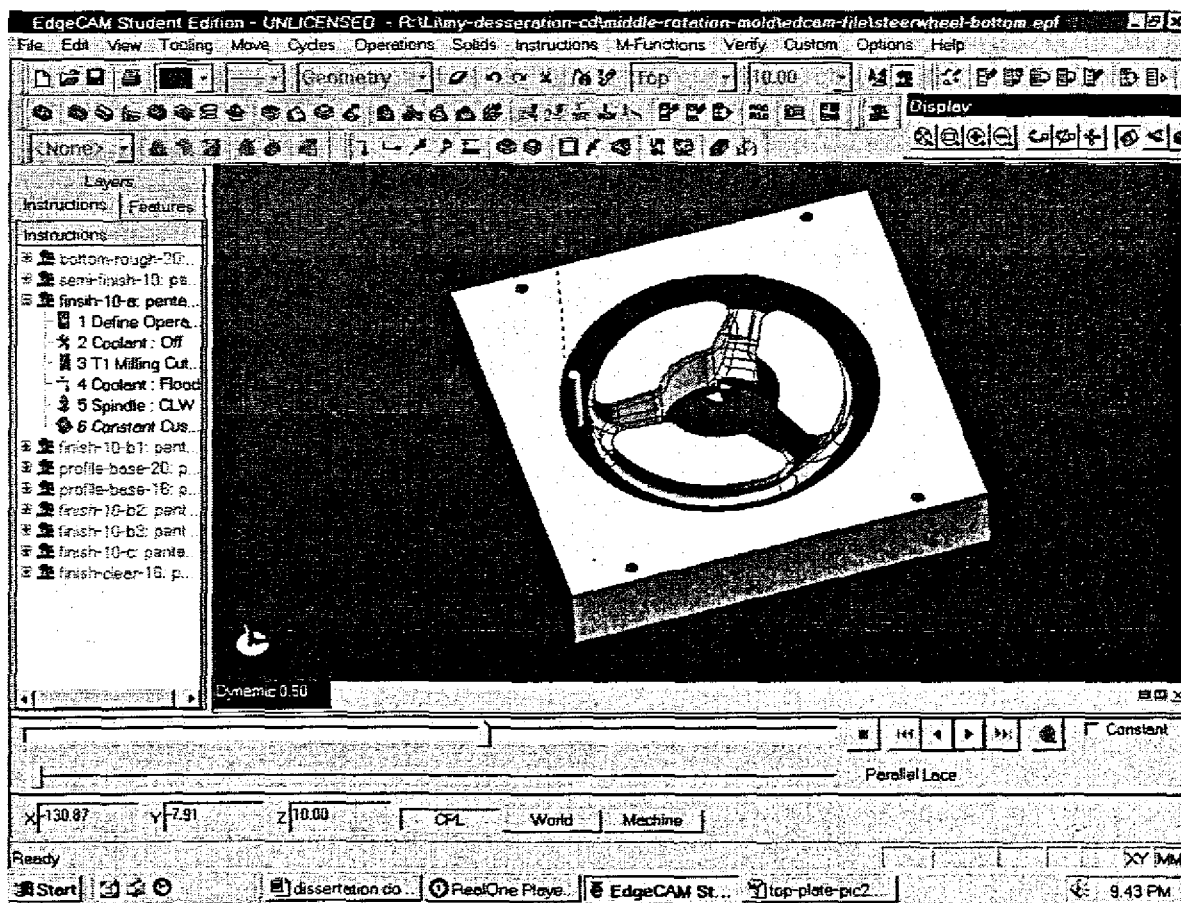

Figure 7.20. Toolpath programming of cavity of the lower plate, product side

7.12. THE LEAD-IN AND LEAD-OUT EXPERIMENT

While machining the lower plate, a problem occurred due to lead-in and lead-out of NC program parts during finishing. The finished cavity surface of the lower plate left some cutting marks on its inner surface, which needed to undergo an additional polishing stage. An experiment has been carried to invest this problem in order to reduce the lead-in and lead-out cutting marks.

An aluminium part is designed for use in this experiment. It has a simple shape and the draft angle on the walls of 10° . Thus the surface operation at the lead-in and lead-out point is easy to program.

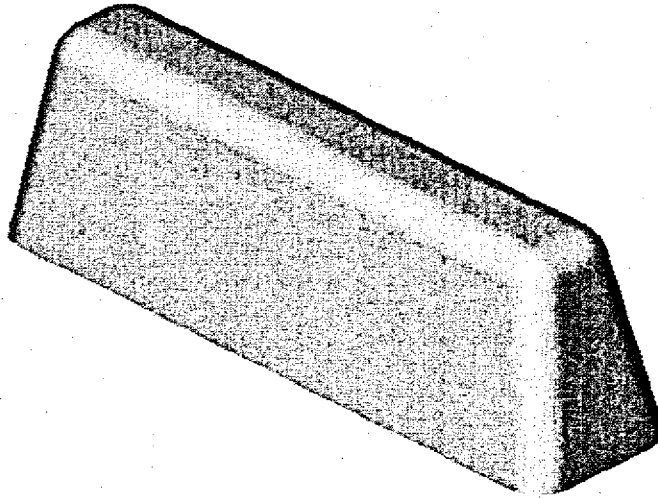

Figure 7.21. Lead-in and lead-out test part CAD model

Two different lead-in and lead-out approaches were examined in this experiment. One was horizontal, and the other tangential. Most of the complicated surfaces can use either of these two lead-in and lead-out approaches.

7.12.1. HORIZONTAL LEAD-IN AND LEAD-OUT

The horizontal lead-in and lead-out was used in the first experiment. From the software picture below, it clearly shows that the Type of the lead is Horizontal, and the Lead-In Angle is 180°, the Lead-In Radius is 5mm and the Lead-In Length is 0.0mm. Equal Lead Moves is ticked.

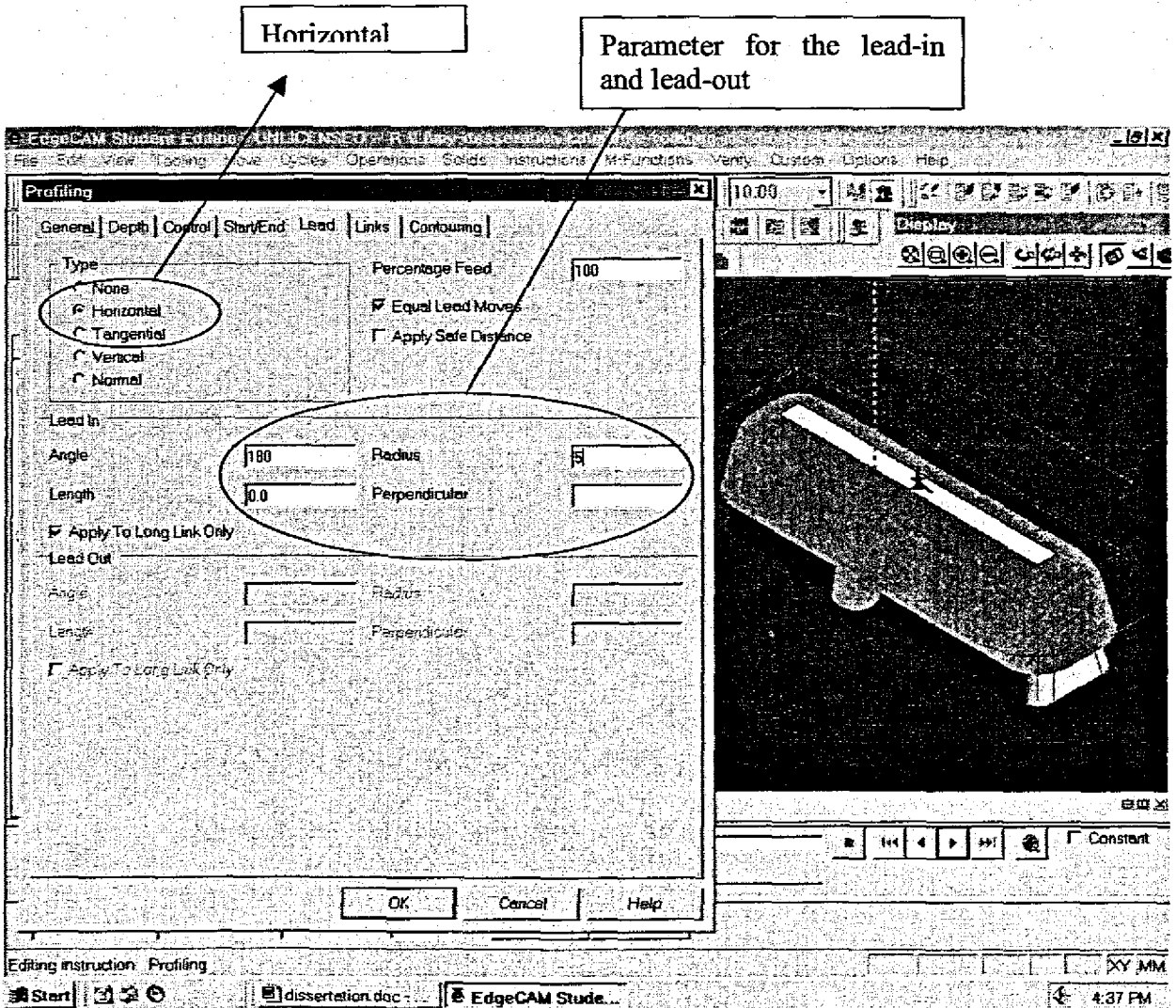

Figure 7.22. Horizontal type lead-in and lead-out EdgeCAM settings

After the CNC machining, there are still lead-in and lead-out marks remaining, see following figure.

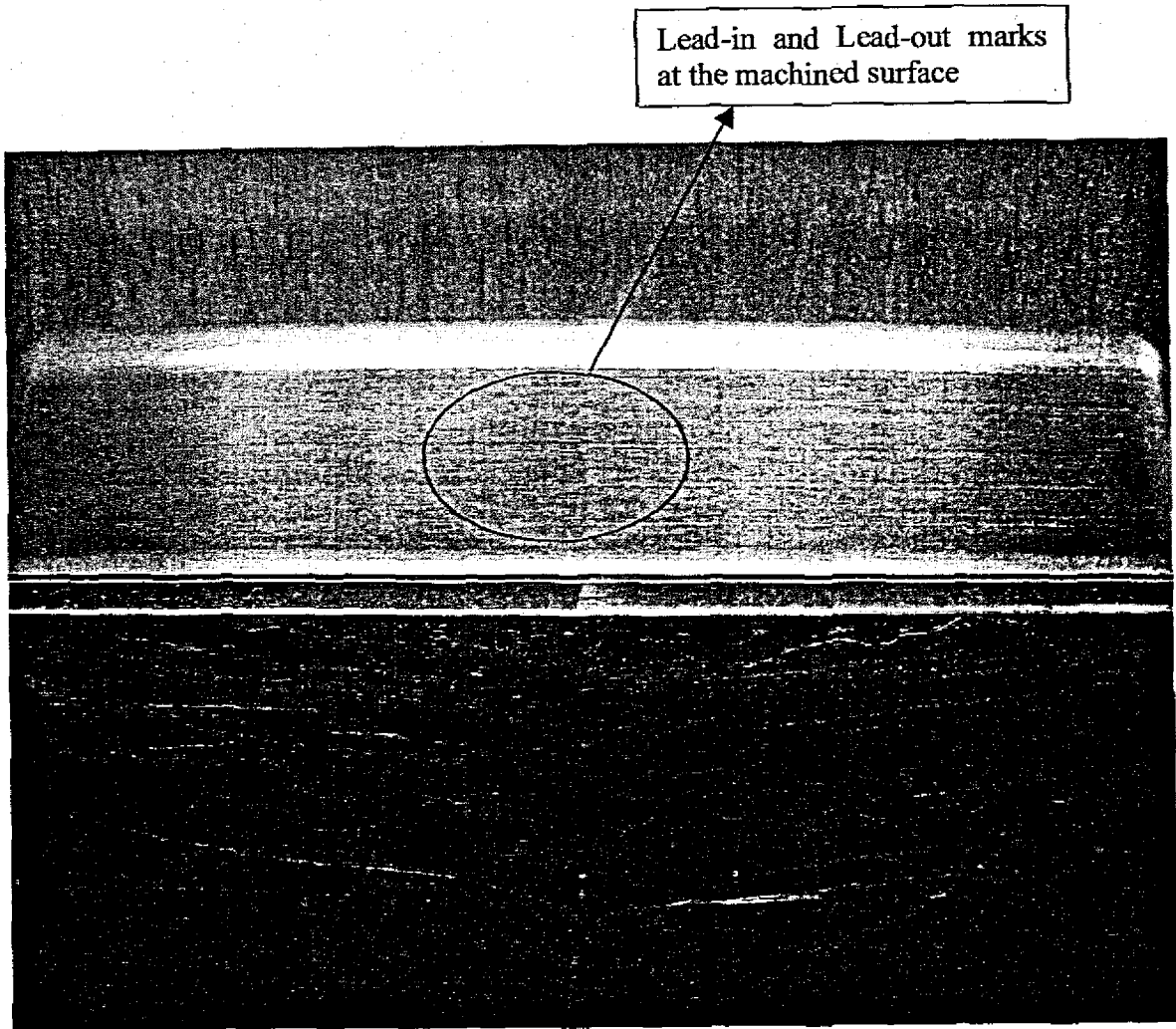

Figure 7.23. Horizontal type lead-in and lead-out result

7.12.2. TANGENTIAL LEAD-IN AND LEAD-OUT APPROACH

The tangential lead-in and lead-out was used in this second experiment. From the software picture below, it clearly shows that the Type of the lead is Tangential, and the Lead-In Angle is 3°, the Lead-In Radius is 20mm and the Lead-In Length is 5.0mm. Equal Lead Moves is also ticked.

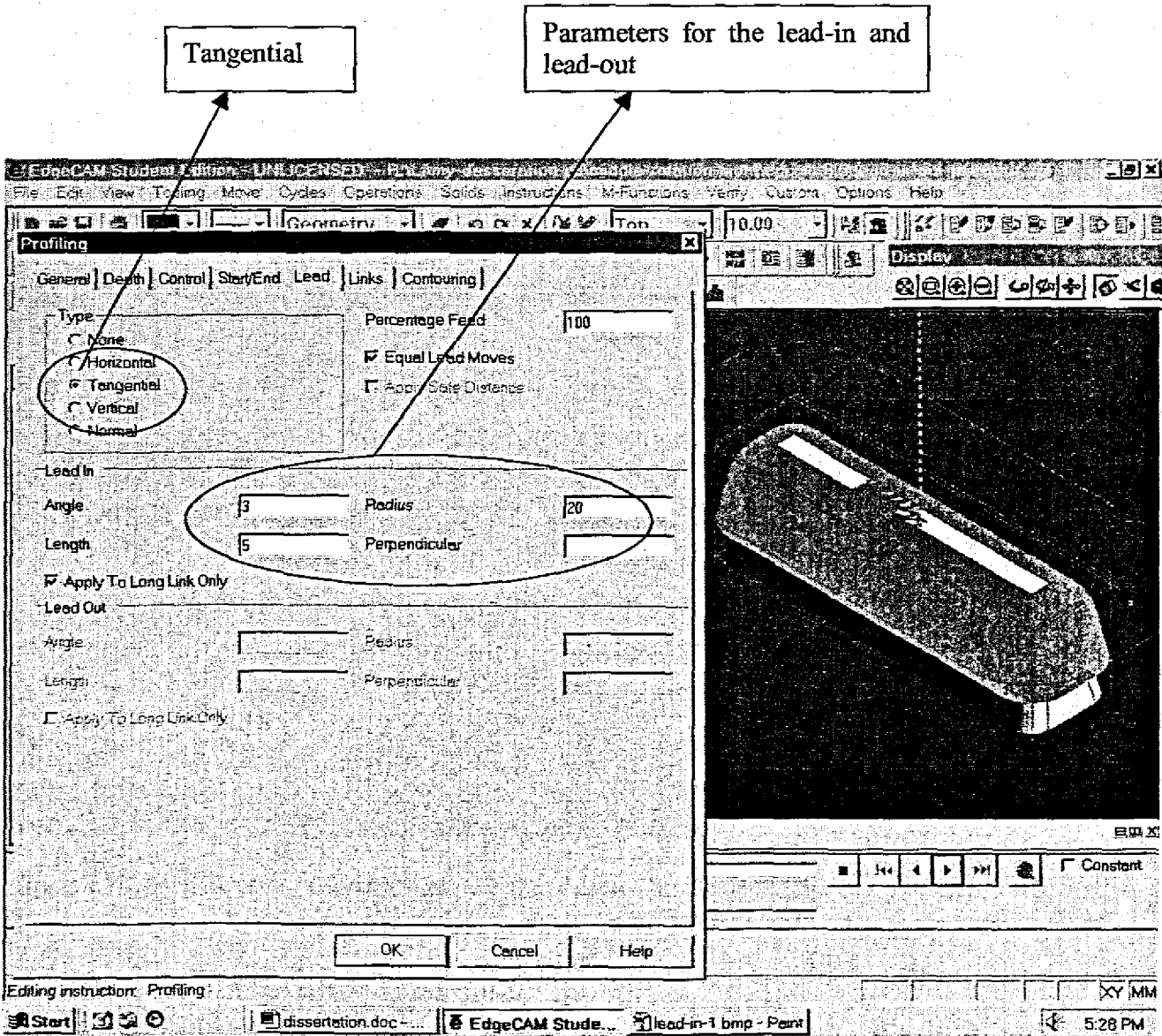

Figure 7.24. Tangential to surface lead-in and lead-out EdgeCAM settings

After this CNC machining, the lead-in and lead-out marks are still there but this time the marks are significantly reduced.

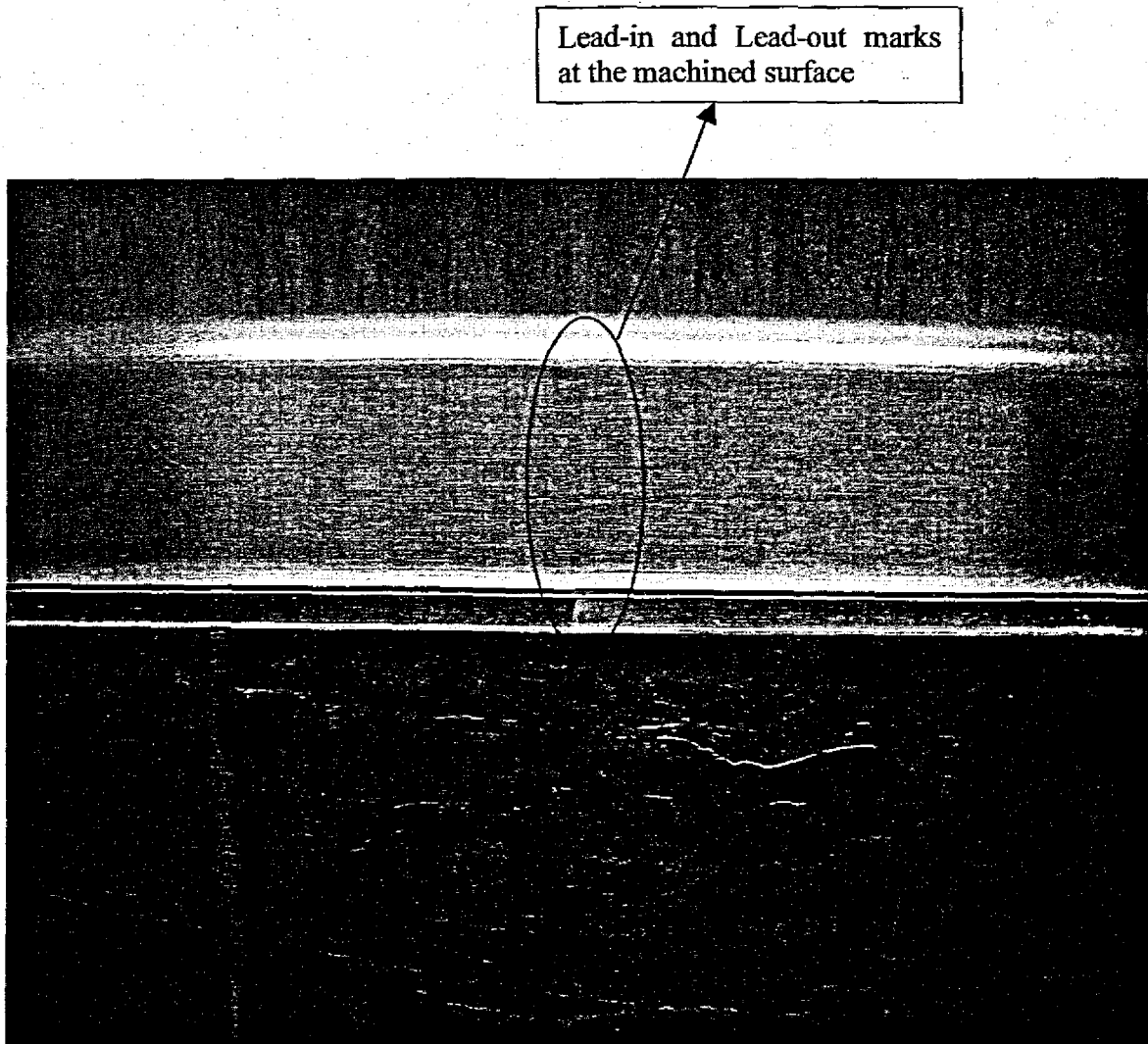

Figure 7.25. Cutting marks at tangential to surface lead-in and lead-out position

7.12.3. EXPERIMENT RESULTS

The following figure gives the visual comparison. Clearly the answer is to use a tangential lead-in and lead-out approach on a very small angle (3°) and a radius ($\varnothing 20\text{mm}$) somewhat bigger than that of the cutter ($\varnothing 10\text{mm}$). Note that during these two experiments the same ball nose cutter, spindle speed and feedrate were used.

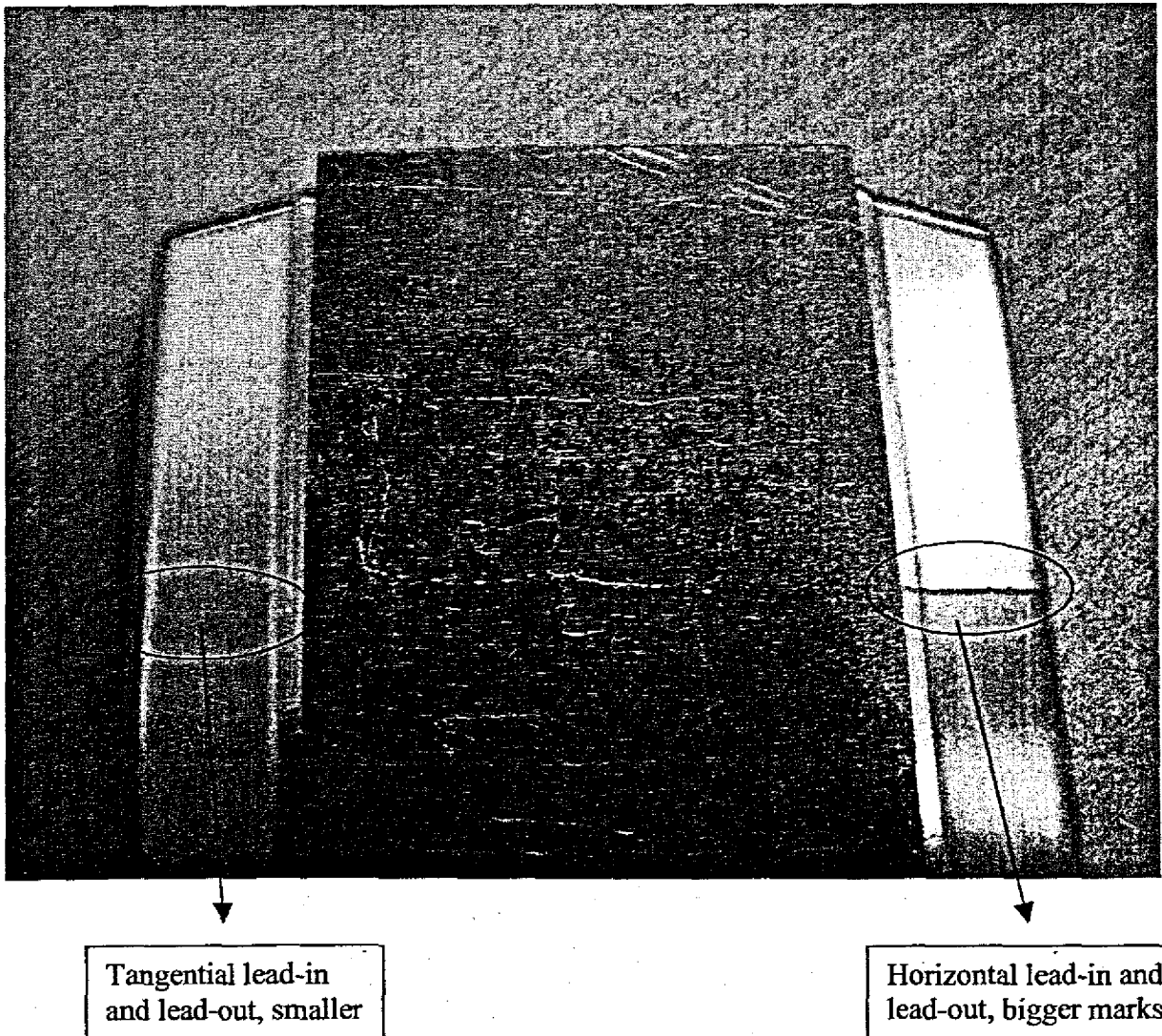

Figure 7.26. Comparison of cutting marks for the two methods

7.13. THE REVERSE SIDE OF THE LOWER MOULD PLATE

Machining of this part reverse side has two elements to it, namely the roughing which is straight forward and the precision finishing of the central insert part hole $\text{\O}60.5\text{mm}$ which is tricky.

The $\text{\O}60.5\text{mm}$ hole is machined to a tolerance of H7 to fit with the insert part machined on a tolerance of h6 giving a close running fit.

The purposes for machining this part reverse side are two; one is to remove the massive material so the part can have a good heat transmission. Another one is to machine the central $\text{\O}60.5\text{mm}$ circle accurately because it will be matched with insert. The tolerance standard adopted for the reverse side central circle and the insert is H7. (H7 is one of the standard tolerances for fitting and turning)

The Z-axis height setting for this part in the CNC machine is very important and must be very accurately done because it determines the location of the parting line. If the workpiece co-ordinate system Z-setting is higher than the model dimension, then the insert will leave a leak gap between the parts. If it is set lower, then the fillet of insert part wouldn't blend smoothly into the flat section on the bottom of the wheel spoke.

Another height setting of importance is the depth of the three M8 holes, which must be shorter than the thickness of the part wall. Also a precision hole is needed for the Ø6mm dowel-pin hole at one of the ears for accurate part location.

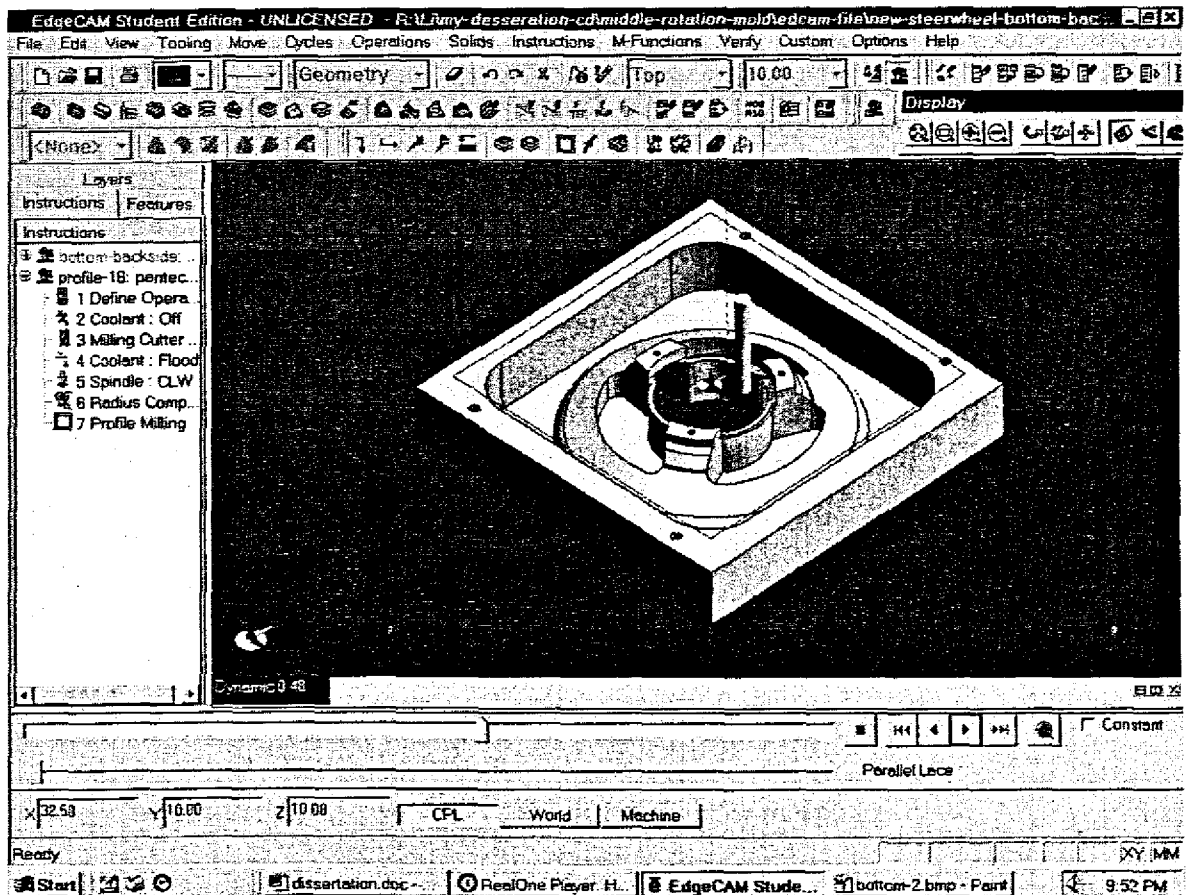

Figure 7.27. Hole toolpath programming of reverse-side of the lower plate

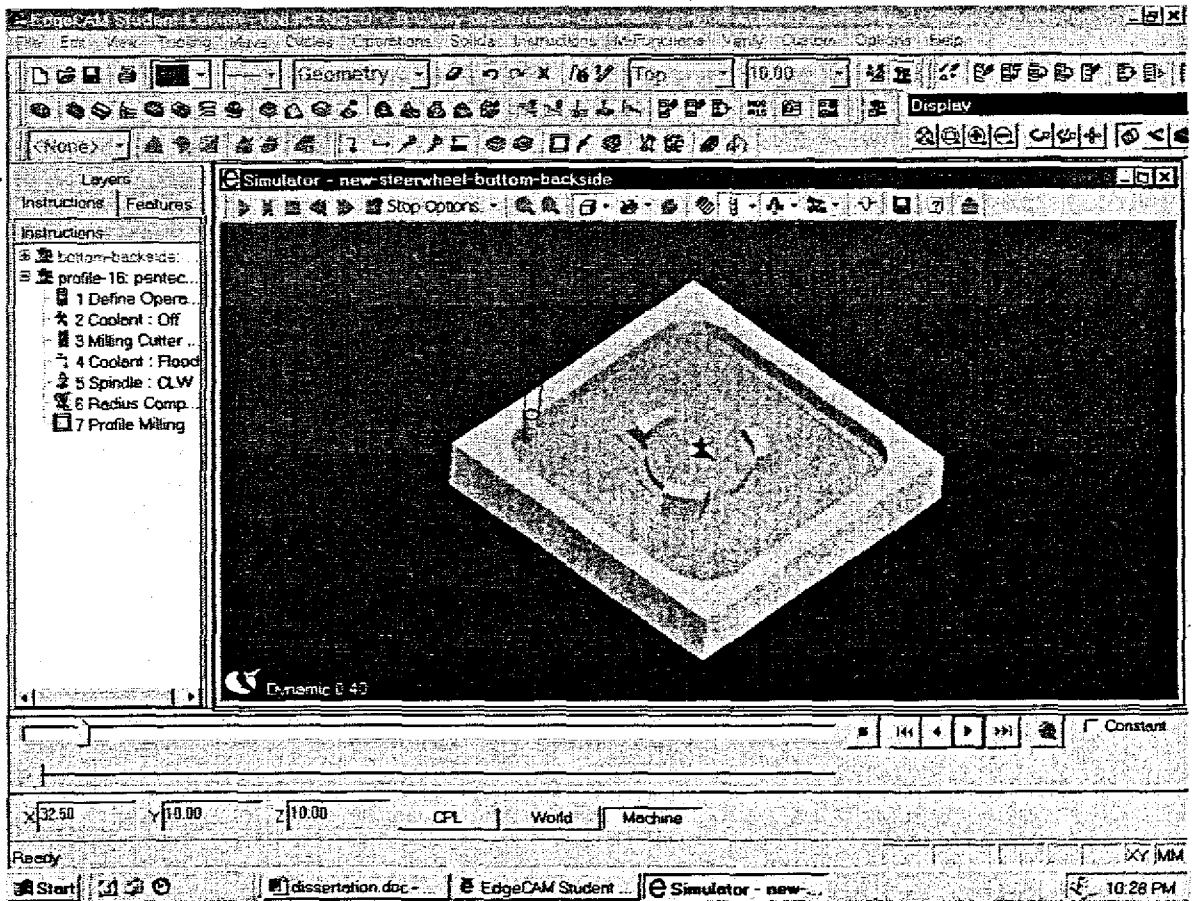

Figure 7.28. Simulation of the reverse side of the lower plate

The part was simulated and cut without any major incident. The precision finishes required some conservative cuts followed by very small increases in offset, measuring between each run - normal practice on precision dimensions.

Table 7.2 Simulation time versus actual cutting time for this part:

	Roughing	Semi-finishing	Finishing	Total
Product side simulation time	1h52min	2h39min20sec	7h35min	12h6min20sec
Product side actual cutting time	1h53min	2h40min	7h45min	12h18min
Reverse side simulation time	2h53min29sec	N/A	N/A	2h53min29sec
Reverse side actual cutting time	2h54min	N/A	N/A	2h54min

7.14. THE MACHINING EXPERIENCE OBTAINED FROM THIS MOULD

During the machining of this mould, some difficulties and problems have occurred because of the part split line, clamping and the need of high quality cavity surface finish. These were all overcome and the machining experience gained is as follows:

Problem: When using a number of smaller toolpaths to cut a large surface, beware of producing lead-in and lead-out marks where the toolpaths join.

Solution: Use only one large finishing toolpath. The many smaller ones can be used with Tangential Lead-in / out and the right settings and there will still be a slight line to show the Lead-in / out positions.

Problem: When using the Ø63mm Seco OctoMill cutter to face the top flange a gentle scalloping is felt. Reducing the Z-increment value to $z=0.1\text{mm}$ helps, but does not totally solve the problem. The material appears to be squeezed out of the way. This is probably due to the rake angle of the cutter.

Solution: Use a Ø16mm Alu-Power slot drill instead of the OctoMill. This solves the problem completely, probably due to the sharp edge and rake angle of the cutter.

Problem: In some cases after the finishing cut, the part cavity may still have undesirable machining marks in some small special areas.

Solution: Manual polishing can treat these small areas. The Speedwell Engineering factory does an excellent polishing job. Presumably this skill can be learned in-house with much practice. It is still better to machine marks out than polish them out.

Problem: Problems experienced with unwanted scallops or cusps.

Solution: Use an EdgeCAM surface toolpath and set the Cusp Height = 0.01mm , the machining Tolerance = 0.008mm and select the Normal to Surface option.

7.15.SOME PICTURES OF THE MEDIUM SIZE ROTATIONAL MOULD

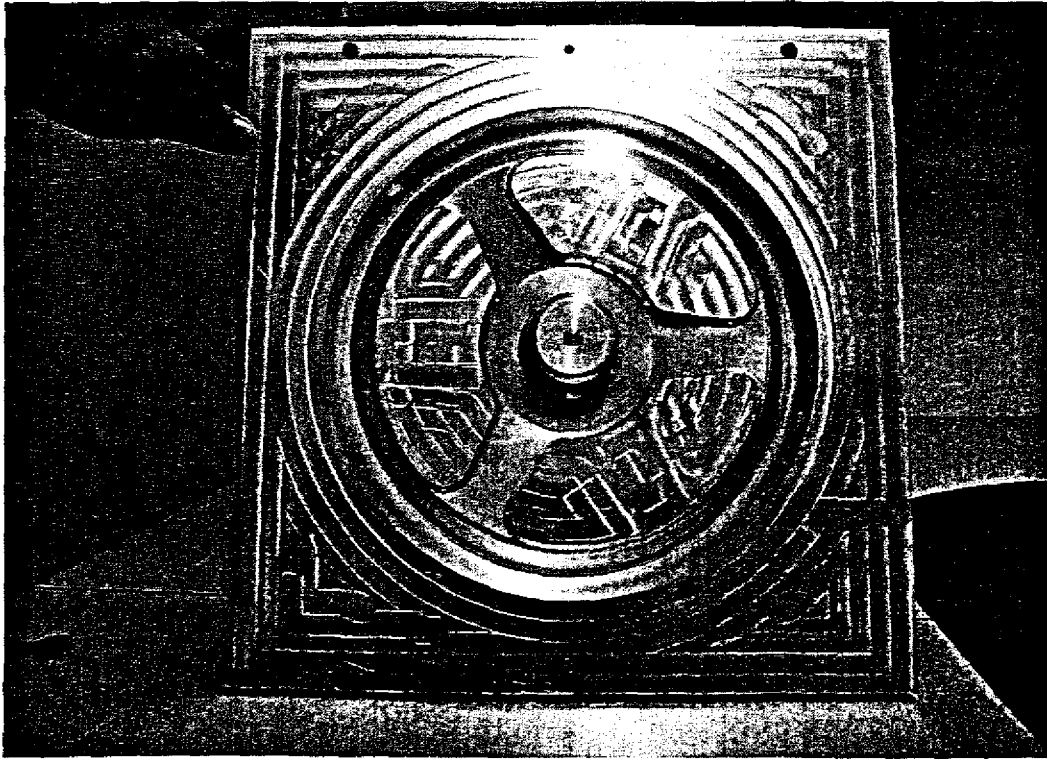

Figure 7.29. Completed top mould half, product side

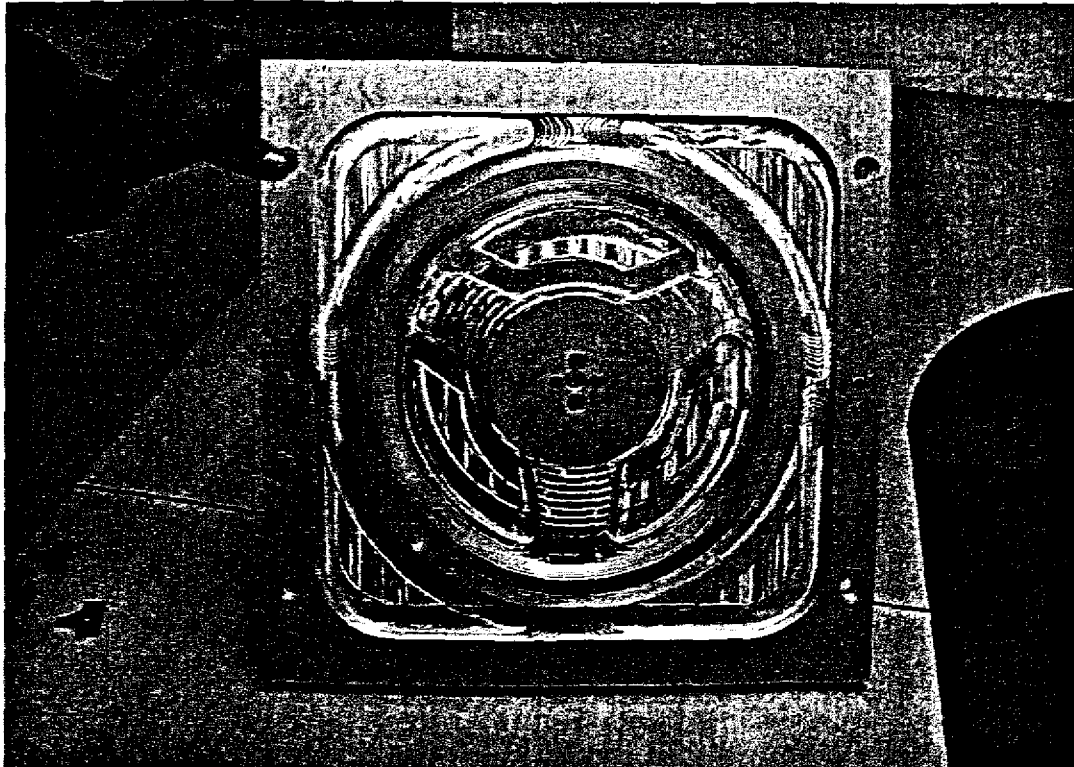

Figure 7.30. Completed top mould half, reverse side

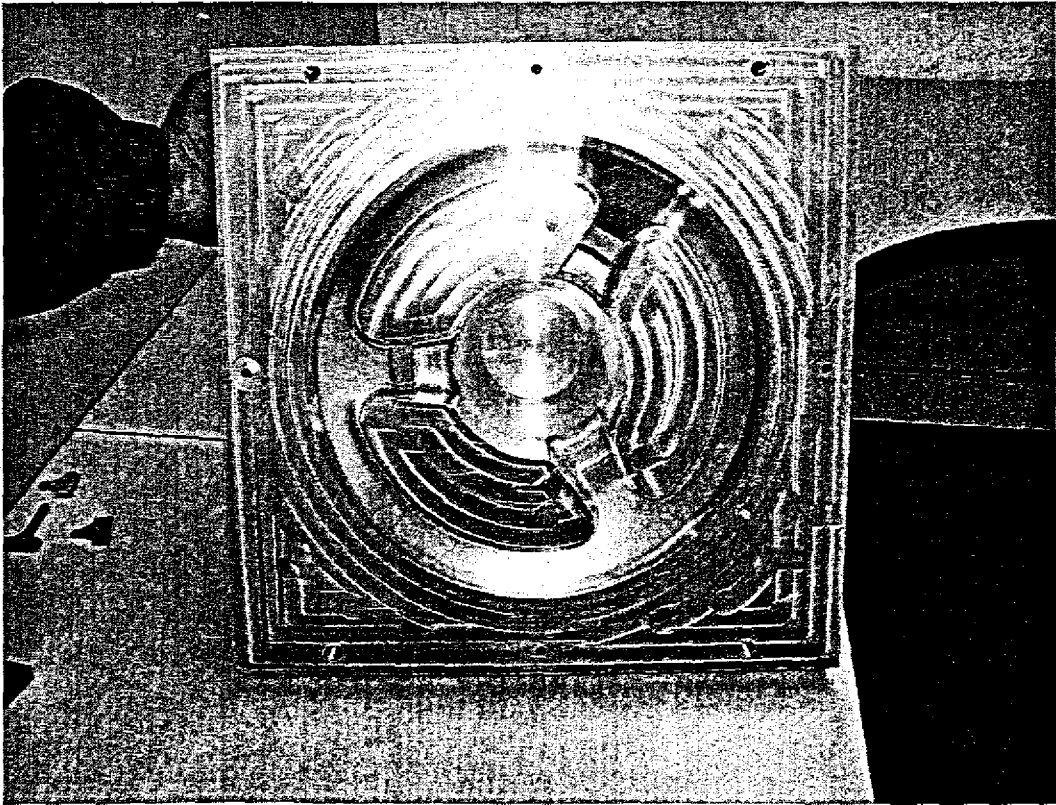

Figure 7.31. Completed lower mould half, product side

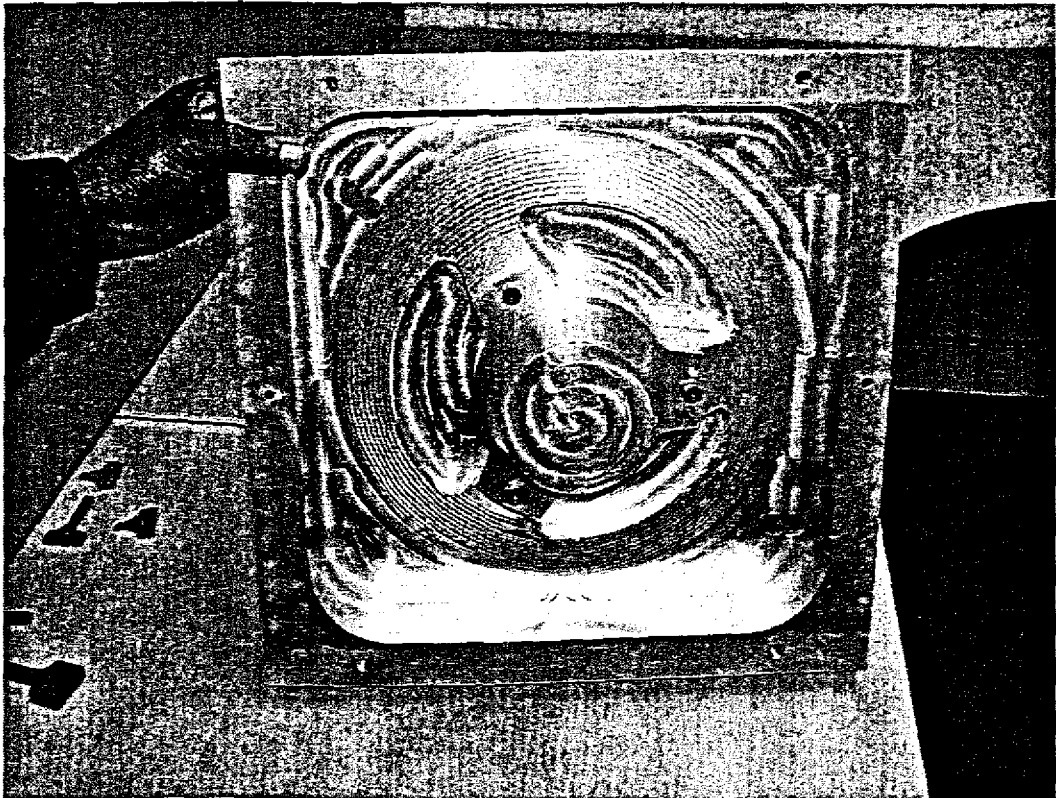

Figure 7.32. Completed lower mould half, reverse side

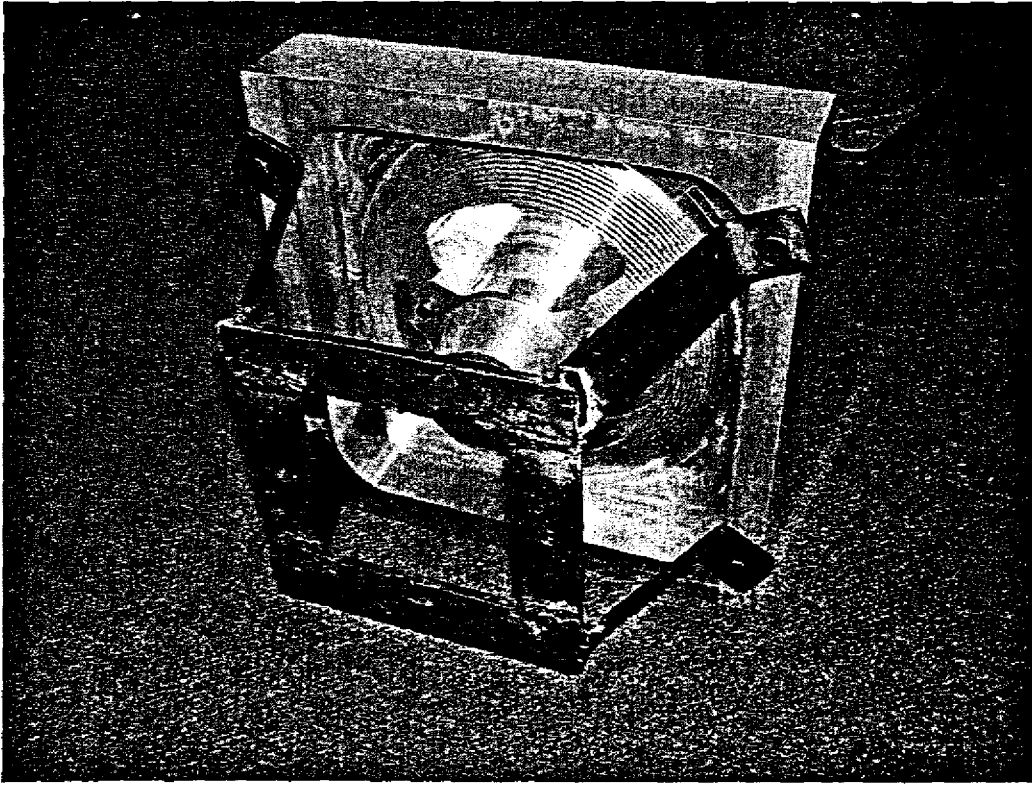

Figure 7.33. Mould assembled in process machine mounting frame
(Compliments of Atlas Plastics)

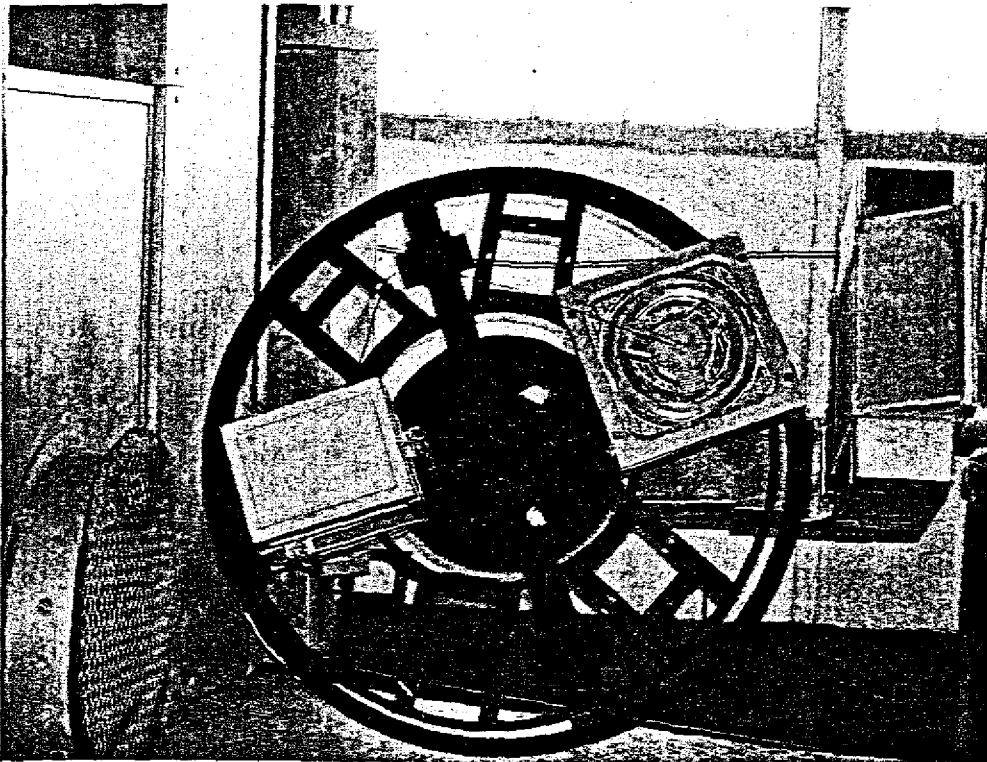

Figure 7.34. Processing of moulding in the rotational machine
(Compliments of Atlas Plastics)

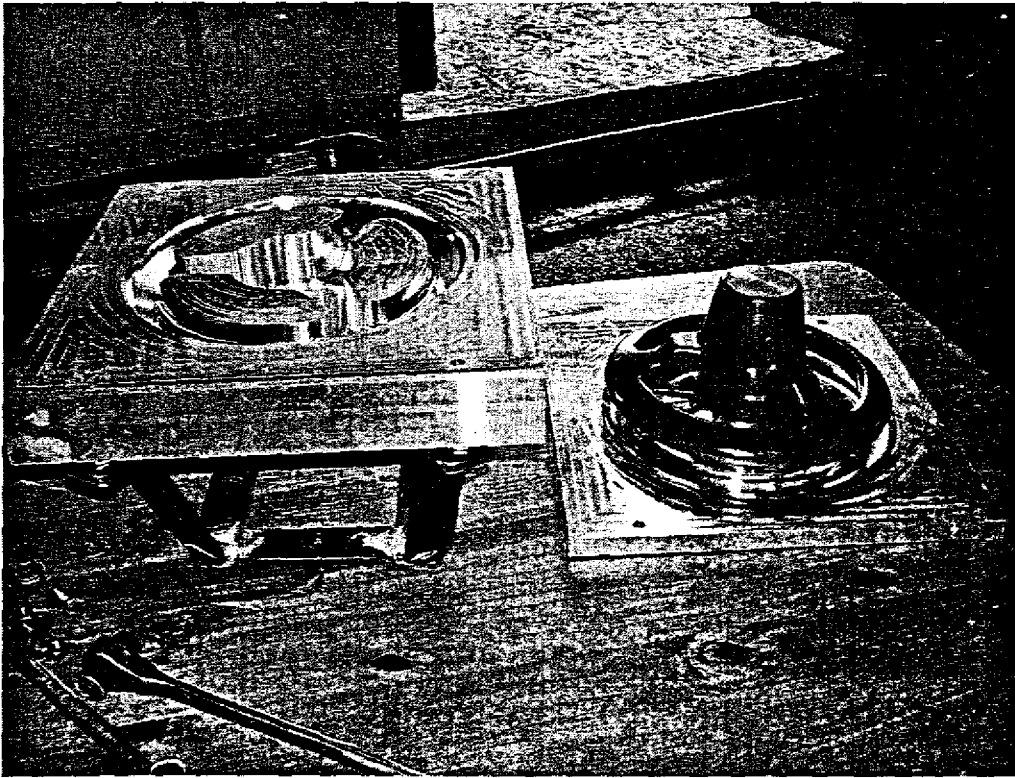

Figure 7.35. Demoulding of first product
(Compliments of Atlas Plastics)

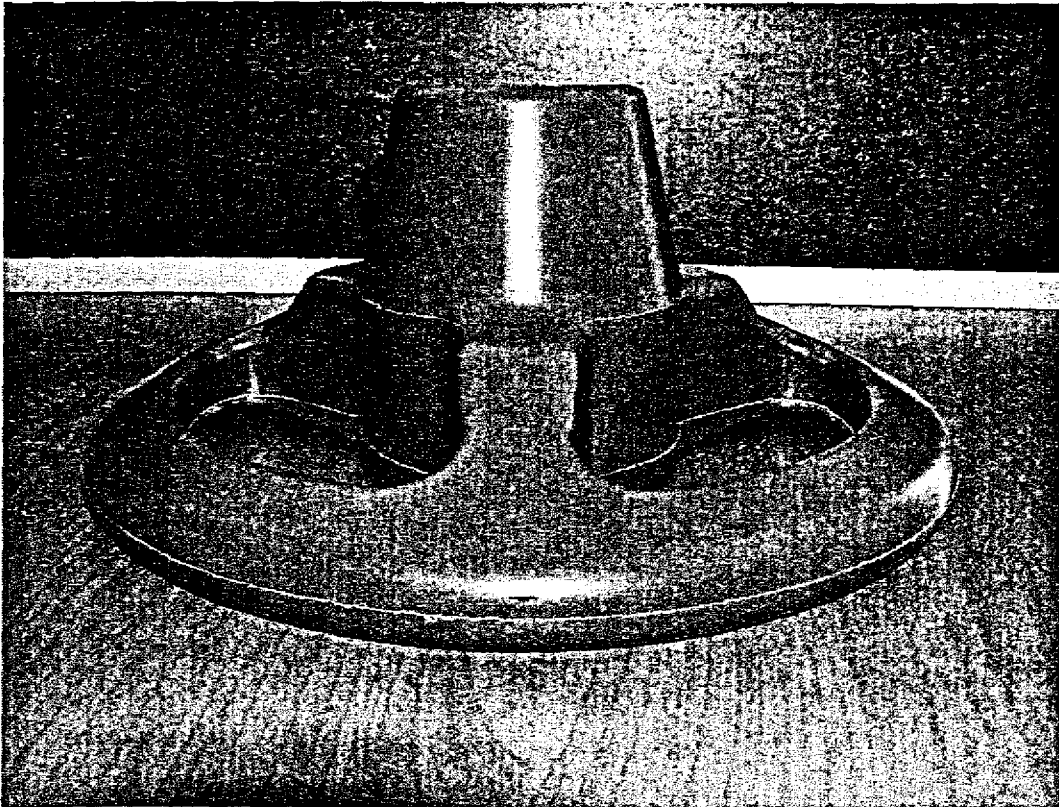

Figure 7.36. Close-up of first product
(Compliments of Atlas Plastics)

7.16.DISCUSSION OF THE MEDIUM SIZE MOULD

The manufacture of this medium size steering wheel mould was a resounding success. See Appendix A, letter from the factory. The concept of mould half subdivision using the boss insert type approach has been proven and demonstrated in action. This strengthens the research hypothesis that at least some large moulds can be sufficiently subdivided in order that they may be machined on medium size CNC machines.

Other significance points:

1. A material saving of almost 50% was achieved in this case study. See the following table.
2. Together with this material saving, goes the corresponding machining.
3. This case study also demonstrates the concept of concurrent subcontracting with the CNC turning parts being able to be manufactured simultaneously to the CNC milled parts, resulting in further reduction in manufacturing lead-time.
4. This case study as with the first case study also provided valuable mould making and CNC machining experience in general, for example the experience with the lead-in / lead-out settings.

Table 7.3 Breakdown of material utilized with and without mould segmentation approach

	Top plate	Lower plate	Insert for top	Insert for lower	Total
Before splitting	$6.5 \times 10^6 \text{ mm}^3$	$16.95 \times 10^6 \text{ mm}^3$	N/A	N/A	$23.455 \times 10^6 \text{ mm}^3$
After splitting	$2.9 \times 10^6 \text{ mm}^3$	$8.66 \times 10^6 \text{ mm}^3$	$0.70 \times 10^6 \text{ mm}^3$	$0.12 \times 10^6 \text{ mm}^3$	$12.385 \times 10^6 \text{ mm}^3$
Saved material	55%	48%	N/A	N/A	47%

CHAPTER 8 LARGE SIZE ROTATIONAL MOULD

The success of the medium size rotational mould proved that a mould can be split into some small segments, and then be assembled together using dowel pins, bolts and nuts. In this third job or case study a large size rotational mould will be considered. The size of the mould represents a typical rotational moulding product. The product is a lit-up advertising billboard.

Having proved the subdivision concept, this case study concentrates on the subcontracting side and issues, to map a way forward for concurrent mould segment manufacture. In this case study only one eighth of a big size symmetrical mould will be machined. The tried and tested CAM data will then be used to test the subcontracting of additional, identical one eighth mould segments.

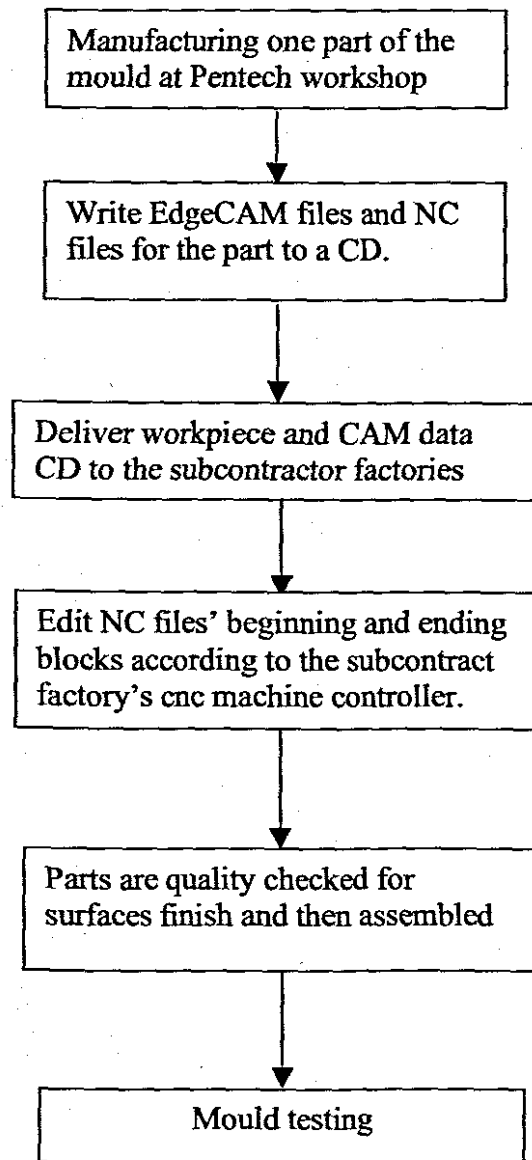

Figure 8.1. Flow diagram of workpieces to be subcontracted

One big departure from previous practice is that on this job the reverse side will be machined first, unlike the previous two moulds where the product side was machined first. The big reason behind this change is one of distortion. The first attempt of this workpiece pulled horribly skew as the material relaxed. The idea to solve this is to do all the rough machining, then remove the workpiece from the clamping arrangement and let it stand for a few days to finish distorting, and then cut the final cavity shape. The reverse side has also been redesigned

8.1. CAD MODEL OF THE PART

The same trusted clamping frame arrangement will again be used on this job. The size of the workpiece is: 435 x 435 x 60mm. In the figure 8.2 of the SolidWorks CAD model notice the egg box webs and thickened pillar on each corner where the clamping boltholes are positioned. These were all added after the first failed attempt to add rigidity. Also notice the bolt on the lowest corner of figure 8.2 does not go all the way through. If it did it would open onto a product surface. This is another reason why the reverse side must be completed first. It might just be that the standard recipe should be that the reverse side is always completed first.

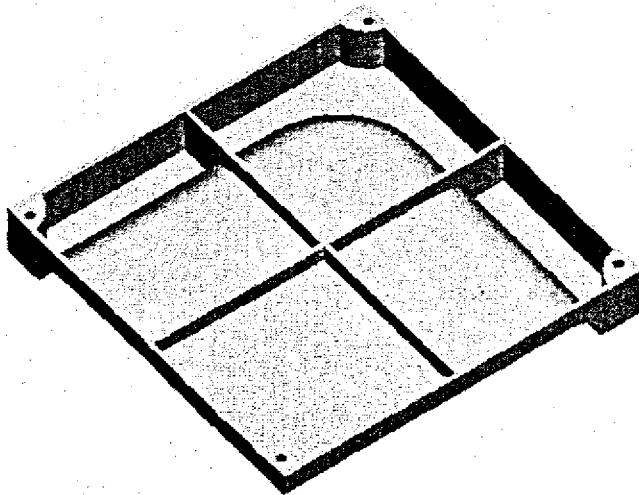

Figure 8.2. CAD model of the reverse side of mould part

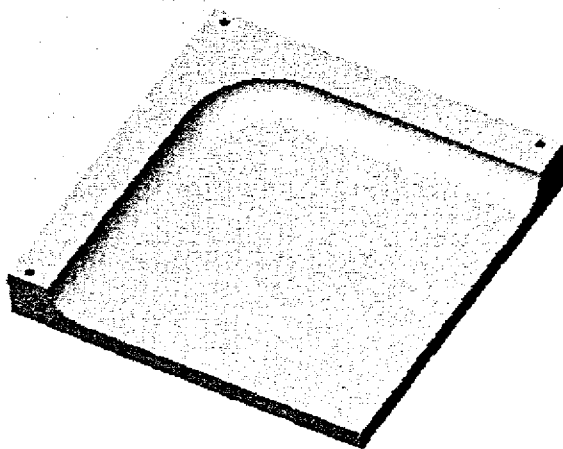

Figure 8.3. CAD model of the product side of mould part

8.2. MANUFACTURING MOULD PART'S REVERSE SIDE

The strategy of machine the reverse side is, first to machine the four outside vertical flange edges, second to machine the reverse side pockets, last to drill and tap the four holes which will be used for clamping when machining the product side.

The cutters to be used for this side are:

1. $\varnothing 40$ mm Seco Copy Cutter with an inserts radius of 6mm used for large volume roughing. On the previous jobs smaller size Seco Turbo Mill cutters were used for this job.
2. $\varnothing 16$ mm Alu-Power slot drill used for the finishing of the four outside vertical flange edges.

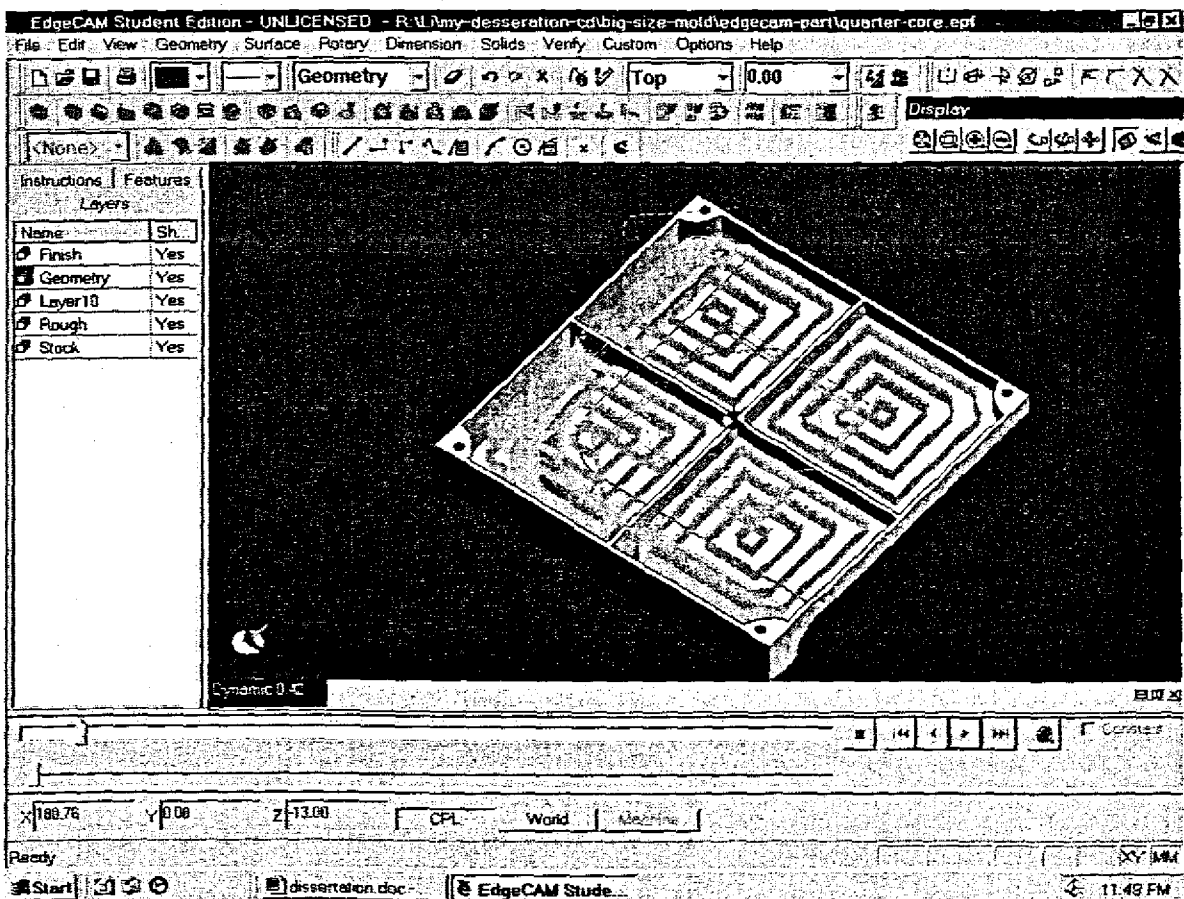

Figure 8.4. Toolpath programming reverse side of mould part

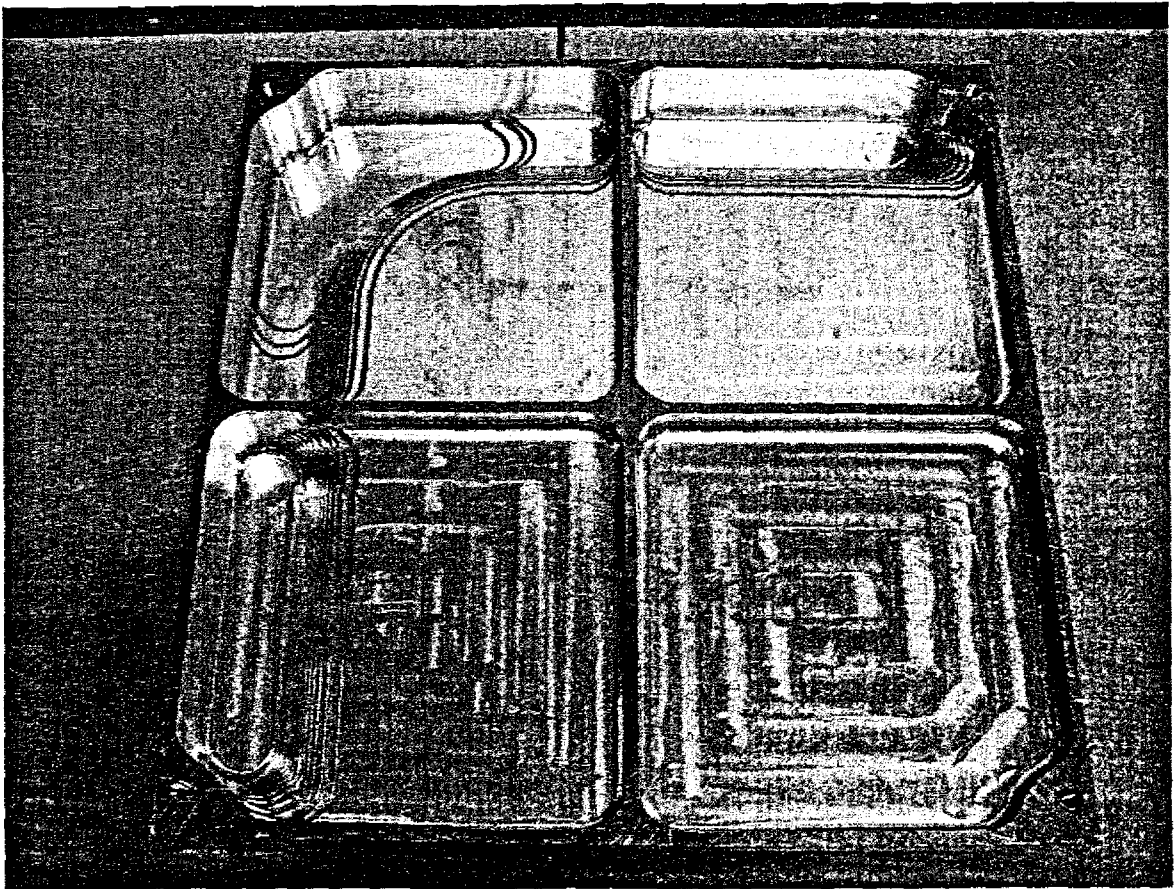

Figure 8.5. Reverse side of mould part after machining

Table 8.1 NC files, which can be used for the subcontract for the reverse side:

NC files	File size	Cutter size	Simulation time	Actual cutting time
2D-Profile-rough-40-backside.nc	8kb	Ø40mm, inserts radius 6mm	27minutes	27minutes
Pocket-rough-40-backside.nc	36kb	Ø40mm, inserts radius 6mm	1hour38minutes	1hour40minutes
Profile-finish-16-backside.nc	1kb	Ø16mm slot drill	4minutes	4minutes

8.3. MANUFACTURING PART'S PRODUCT SIDE

The strategy for the product side is, firstly to do the roughing, then unclamp the workpiece and let it rest, next complete the cavity pocket, and finally to face the top flange surface.

The cutters to be used for this side are:

1. Ø40mm Seco Copy Cutter with an inserts radius of 6mm used for the large volume roughing of the cavity.
2. Ø16mm Alu-Power slot drill used for the finish facing of the top flange surface.
3. Ø10mm Alu-Power ball nose cutter used for the finishing the filleted corner of the product cavity.

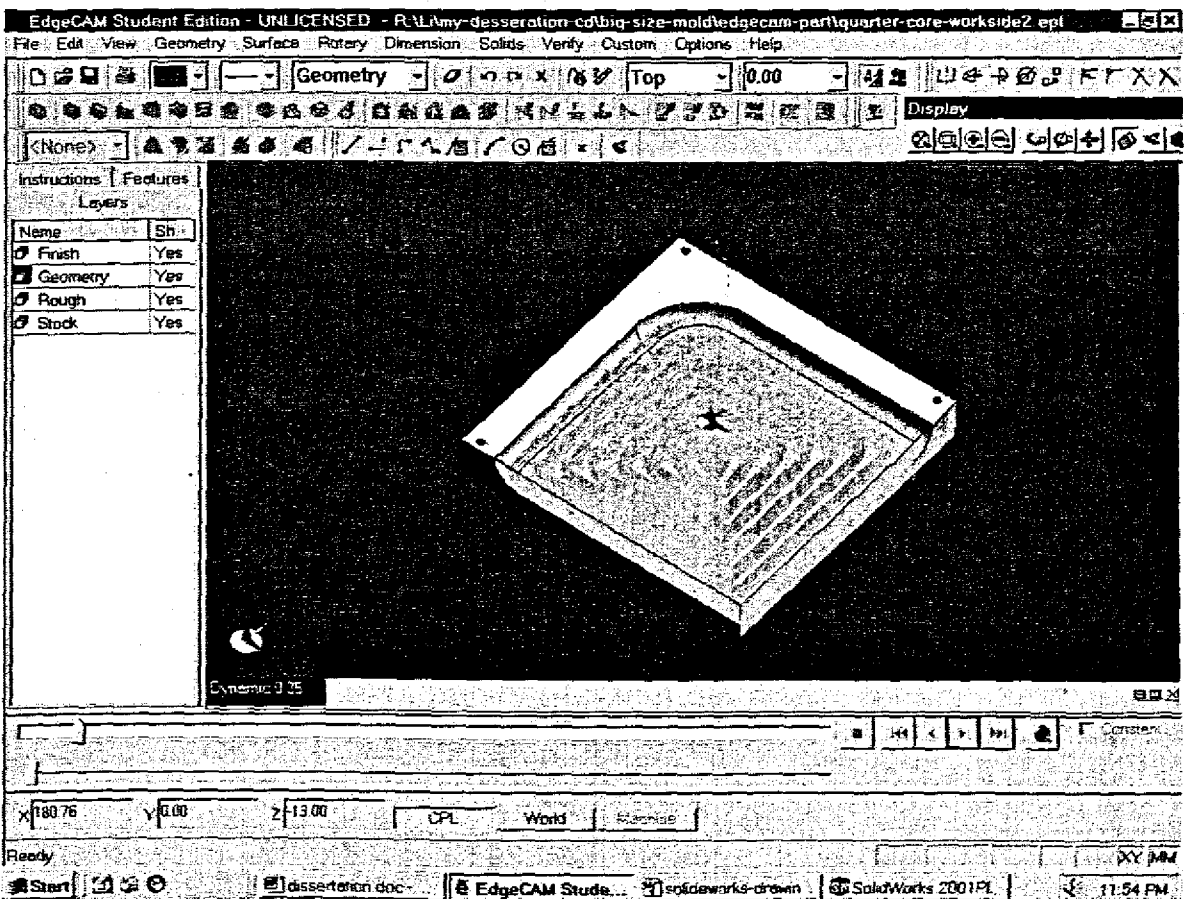

Figure 8.6. Toolpath programming product side of mould part

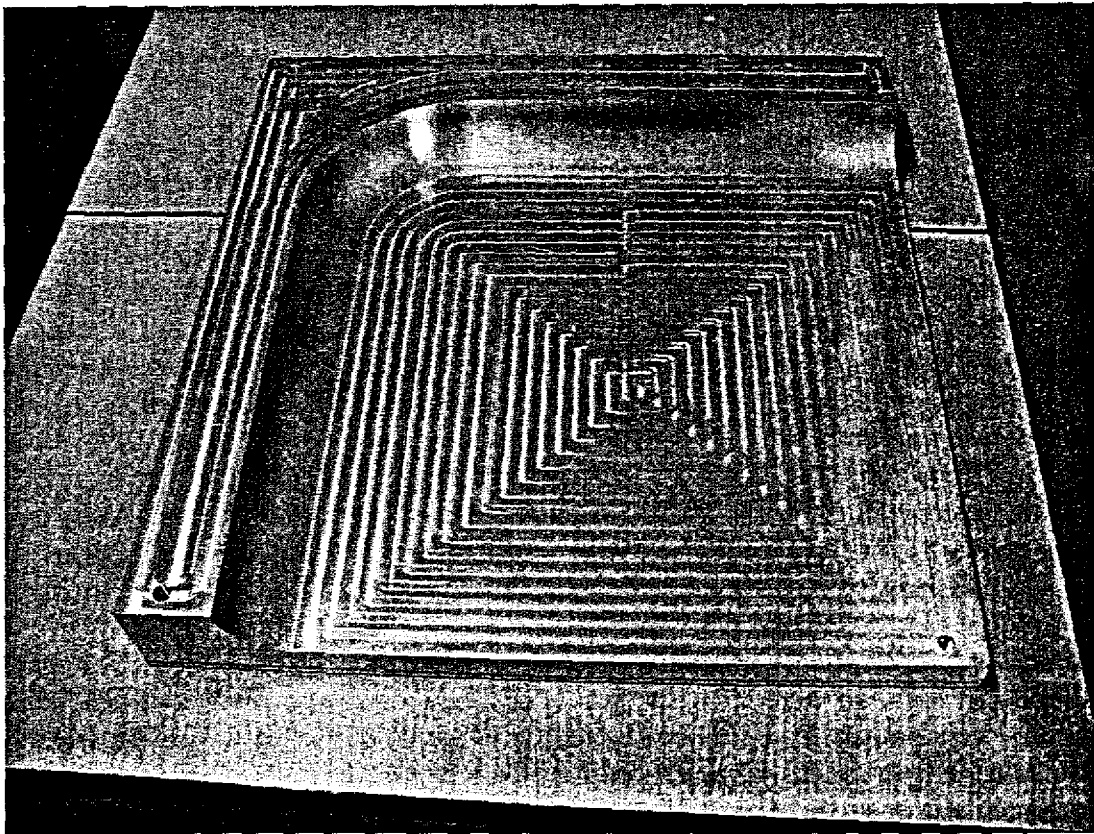

Figure 8.7. Product side of the part after being machined

Table 8.2 NC files, which can be used for subcontracting of the product side:

NC files	File size	Cutter size	Simulation time	Actual cutting time
Surface-rough-40-cavityside.nc	20kb	Ø40mm, inserts radius 6mm	1hour23min	1hour25min
Facing-16-cavityside.nc	3kb	Ø16mm slot drill	21min	22min
Surface-finish-12-cavityside	22kb	Ø12mm ball nose	1hour9min	1hour10min

8.4. SUBCONTRACTING METHODOLOGY

In South Africa there are two popular CAM packages that are used by local mould making companies. One is MasterCAM and the other is EdgeCAM. In this research project, all the toolpaths for the mould parts have been created using EdgeCAM. The best method of transferring CAM data, i.e. the toolpaths with all their settings, to subcontractors is by means of a CAM file. That means that both the principle and the subcontractors will need to have the same CAM software, EdgeCAM, and also the version that each own will need to be exactly the same. The experience shows even version differences cause so many hassles that it is not worth travelling that road. The route of the same CAM software is possible as shown by the Volkswagen factory only accepting subcontractors that run their versions of the Catia CAD package. They write this into all their contracting documentation. A factory like this is big enough to have the buying power to get away with this type of prescription. This is not the case in the rotational moulding industry, thus probably a different route will be needed.

With CAD data there are a number of standard formats that can be used to transfer this CAD data from one CAD package to another. Examples of these file transfer formats are STL files, stereo lithography files used in the rapid prototyping industry, STEP files, SAT or ACIS files and IGES files, of which IGES files are the most popular. Just about all CAD packages read IGES files so this is generally the format used to transfer 3D models. This standard transfer format does not exist for CAM data. The CAD data contains the shape or geometry of the mould, so this can be transferred everywhere even to all CAM software. As already mentioned CAM data contains the toolpaths with all their settings. The mould machining success and finish is locked up in all the finer details of the toolpaths. Thus successful subcontracting demands transfer of the CAM data or else the NC files which result from the toolpaths.

The EdgeCAM suppliers charge large prices for version upgrade, typically more than R10 000 per seat of EdgeCAM. This fact result in the machine shop users of EdgeCAM all having a myriad of different versions. Now even if a potential subcontractor on this project has exactly the same version as Pentech i.e. EdgeCAM V8.75, he still cannot open Pentech's CAM file. Pentech owns an educational Version 8.75 which saves the CAM data in a .EPF file while commercial Version 8.75 EdgeCAMs save the CAM data in a .EPP file. The two file types are purposely programmed by Pathtrace, the authors of EdgeCAM, not to be compatible. Thus the first prize of subcontracting with EdgeCAM files is not available, it only leaves one option that is to subcontract with NC files.

The NC files are the easiest and simplest ways to manage the subcontracting. The NC files can be directly inputted to the CNC machines to drive the machining of the parts. The advantage of this kind of files is that it can bring the almost same lead-time and cost to the same parts because inside the NC files the cutting parameters, like spindle speed, feedrate, and plunge rate are same. It also saves the subcontractors the code generation time as this code is supplied. The disadvantages of NC files are:

1. Subcontractors generally do not have software that can run simulations of NC files directly on their computers. This software is commercially available but the CAM simulations are usually enough. Pentech has their own in-house NC files

simulation software, but this is not suitable for the larger files of complex moulds. Possible for the future this can be improved.

2. Sometimes the NC files need to have their header and tails changed (i.e. some codes in the first few files and the last few lines of the NC file changed). This is brought about due to small difference in machine start-up setting and some very few specialized codes being different on different machines.
3. There was an opinion out there in the industry that many machine shops do not want to accept NC files because it is in fact telling them how to drive their CNC machine. If one spends R500 000 plus on a machine then one does not need someone telling you how to drive this expensive machine.

It is felt that the disadvantages of subcontracting with NC files can easily be overcome and therefore this is the correct route for this project. Dry running the NC code will give the subcontractors the confidence to use it without a PC simulation. The small NC file changes between machine controller types are believed to be trivially handled during dry running. Lastly, subcontractors have been found who are willing to subcontract using NC files. Two subcontractors will be used, namely ISP Plastics and C.F.W. Industrial.

The NC files used in this project were programmed in EdgeCAM 8.75 Educational. The controller of Pentech's CNC machine is a Fanuc controller. ISP Plastics has EdgeCAM 8.75 Commercial and a CNC machine with a different controller. C.F.W. Industrial has MasterCAM and a CNC machine with the same Fanuc controller. The differences represent a good mix of variation.

The files prepared for the subcontractors include:

1. **Quarter-part.igs** 257kb
3D drawing IGES files, for visual reference and viewing only

NC files of the part used for the subcontract:

- | | | | | |
|----|---|------|------------------|--------|
| 2. | 2D-Profile-rough-40-backside.nc
6mm | 8kb | Ø40mm, inserts | radius |
| 3. | Pocket-rough-40-backside.nc
6mm | 36kb | Ø40mm, inserts | radius |
| 4. | Profile-finish-16-backside.nc | 1kb | Ø16mm slot drill | |
| 5. | Surface-rough-40-cavityside.nc
6mm | 20kb | Ø40mm, inserts | radius |
| 6. | Facing-16-cavityside.nc | 3kb | Ø16mm slot drill | |
| 7. | Surface-finish-12-cavityside.nc | 22kb | Ø12mm ball nose | |

The total actual machine time used for the part at the Pentech workshop is 4 hours 58 minutes, not including the workpiece clocking and tool setup time.

8.5. ISP PLASTICS

ISP Plastics is located in Bellville South Industria, Cape Town. It has a tool-room, which can manufacture plastic injection moulds and blow moulds for customers. The equipments in the tool-room includes one CNC milling machine and other conventional milling machines and lathes.

The CNC milling machine

Manufacturer of the machine: Haas Automation, Inc, American
X, Y, and Z travel size: 1200 x 1000 x 800mm
Controller of the machine: Haas controller

CAM Software used at the tool-room: EdgeCAM 8.75

Cutters used in the tool room

Most of the insert type cutters used in the tool room are Iscar cutters, including roughing and finishing cutters. Usually each machine shop will choose one insert cutter make and stick with it to prevent insert holder duplication, ISP Plastics chose Iscar where Pentech chose Seco. Normal HSS cutters are available.

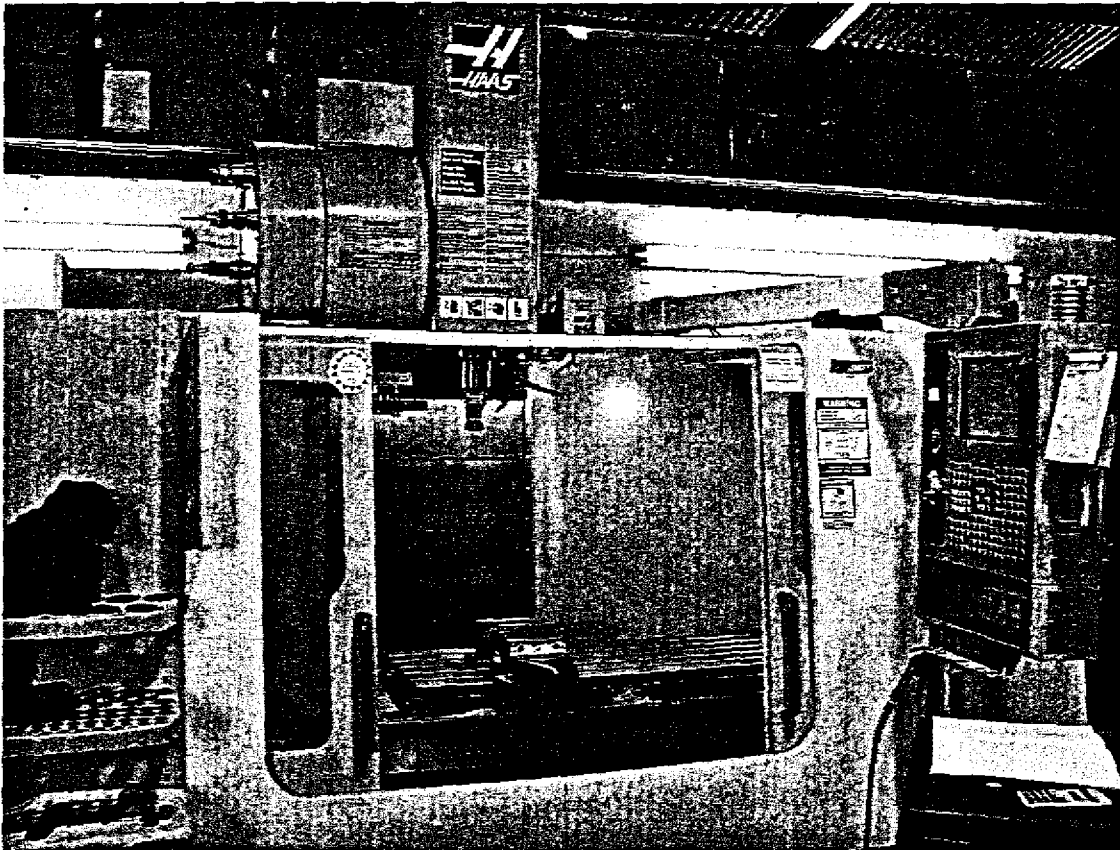

Figure 8.8. CNC milling machine at ISP Company
(Compliments of ISP Company)

File checking

ISP Plastics was very cooperative in this investigation. Their NC programmer and machine operator checked all the NC files and did all the dry run testing on the provided NC files.

The **Quarter-part.igs** file was imported into their EdgeCAM 8.75 for a visual of the 3D CAD model.

The NC files were all opened individually and their headers and tails were checked by their NC programmer and found to be 100% compatible with their machines controller.

The beginning blocks in the provided NC files are:

```
%  
O0001 (quarter-core-cavity-side) (face-16)  
(CUT TIME=22.0MIN)  
G90 G55  
(T01=ENDMILL=USER DEFINED D16.0)  
(DEFINE OPERATION: POCKET OPERATION)  
T01 M06  
(ENDMILL=USER DEFINED D16.0)  
S5500 M3  
G0 X-173.1 Y165.989  
G43 Z10.0 H01 M8  
G1 Z0.0 F600
```

The ending blocks in the provided NC files are:

```
G0 Z10.0  
M05  
M09  
Z100  
G40  
M30  
%
```

The only changes suggested were that on spindle speed and feedrate. The reason for these changes is the fact that their machine has a higher maximum spindle speed of 8000rpm versus the 6000rpm of Pentech's machine. Thus maximum spindle speeds were adjusted to the new maximum. ISP Plastics like to run at lower chip loads and thus feed rates to further improve surface finish at cost of greater machining time. It is believed Pentech's tried and tested recipe on this is still the best.

Dry running the NC files

In order to be 100% confident on the usage of the supplied NC files despite the assurances of 100% code compatibility the dry runs are still necessary. A dry run means that the workpiece co-ordinate system is lifted say 100mm above any workpiece and the cutter then cuts fresh air. All feed overrides are then set to maximum to greatly reduce the run time. This will show up any code errors or movement errors. The toolpath has a pattern familiar to the programmers and simply watching the cutter movement especially at increase feeds allows one to easily pickup most errors. Dry runs can be time consuming, say up to one third of the normal machining time. Allowance might need to be made for this. The ISP Plastics's machine operator did the dry run test with all the provided NC files, and each ran smoothly without any errors.

Having done all the necessary testing and investigation ISP Plastics then proceeded to quote on the job.

I S Plastics (Pty) Ltd

Reg. No. 2002/015589/07

P O Box 651 Santamhof 7532
Proton Street Stidand Cape Town South Africa
Tel: (+27 21) 949 4581 Fax: (+27 21) 949 4585

AD: MR WANJUN LI C/O PENTECH BELLVILLE
EX: IVOR MINNAAR 7 December 2004
RE: QUOTE : MACHINING SEGMENT OF LARGE MOULDS

As discussed:

- a) Material : Aluminium General Purpose to be supplied by customer
- b) Special Tools : N/A
- c) Blocking up and prep work : 2.5 hours @ R200.00
- d) Machining time as per programme : 7 hours @ R400.00

The cost will be	R3300.00
Consumables and sundries	250.00
TOTAL	R3550.00 excluding VAT

Terms: COD

Sincerely

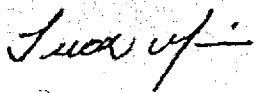

Figure 8.9. Subcontractor's quotation from the ISP Company

8.6. C.F.W. INDUSTRIAL

C.F.W. Industrial is located in Parow Industria, Cape Town. It has a tool-room, which mainly manufactures dies and containers for customers. The equipments in the tool-room includes one CNC milling machine, two CNC lathes and other conventional milling machines and lathes.

The CNC milling machine

Manufacturer of the machine:

Eumach, Taiwan Company

X, Y, and Z travel size:

1000 x 800 x 650mm

Controller of the machine:

Fanuc controller

CAM Software used

MasterCAM 10.0

Cutters used at the tool room

This company favours Seco insert type cutters and X-Power cutters. These are the makes of cutter most often used in Pentech's workshop.



CFW INDUSTRIES (PTY) Ltd
Tel: +27-21-831 8331
Fax: +27-21-831 8324
Email: natalie@cfw.co.za

HEAD OFFICE: Cape Town
7 Park Road, Parow Industria
PO Box 1642, Parow, 7499
South Africa

Quotation

TO: PenTech

PH: _____

Fax: _____

DATE: 07-Dec-04

ATT: Wanjun-Li

Ref: _____

Dear Sir
Thank you for giving me the opportunity to quote on goods / services as detailed below.
We trust the following meets with your approval.

ITEM	QTY.	DESCRIPTION	UNIT PRICE	AMOUNT
A	1	To machine aluminium rotational mould on CNC Milling machine	R 3,250.00	R 3,250.00

Bank: Standard Bank
Branch: Parow
code: 31110
Acc No: 07276 8793

SUB TOTAL R 3,250.00
VAT @ 14% R 455.00
TOTAL R 3,705.00

VALIDITY: - 30 Days
TERMS OF PAYMENT: #NAME? (blank)
ESTIMATED DELIVERY: - To be arranged
CONDITIONS:
- Excludes supply of material
- Subject to our standard conditions of sale, a copy of which is available upon request.
- Note: Service repairs carry a three month guarantee against defective workmanship.
- New parts carry 1 year manufacturers guarantee.

ACCEPTED BY: _____

DATE: _____



REPRESENTED BY: **Murray Reed**
Proprietor/Dir. - Parow Div
CFW INDUSTRIES (Pty.) Ltd.

Reg. No. 1958/22124/07 - Established 1958 - www.cfw.co.za - Johannesburg Office +27 11 875 7955
 AREA & CENTRAL USE: FIBRE / VEGETATION REMOVAL / TREE COLLARS / PULP & PASTE EXTRACTION / PAPERMAKING / CORRUGATED / FIBRE BOARD
 MOLD & EXTRUSION & REEL FABRICATION / CNC / PUNCHING / DRILLING & COMPONENTS / PARTS / ACCESSORIES / AIR CONTROLS / SPECIAL ALUMINIUM CASTING
 DIRECTORS: MR. MURRAY REED (CHAIRMAN); A. REED (V.P.); S. B. REED (MANAGING DIR.); MURRAY REED (P.O. BOX 1642, PAROW, 7499); M. REED (P.O. BOX 1642, PAROW, 7499)

Figure 8.10. Quotation from the C.F.W Industrial Company

8.7. DISCUSSION OF SUBCONTRACTING

Clearly the chosen method of transferring toolpath data to the subcontractors has been successful despite scepticism from some quarters. All parts can be subcontracted using IGES files for the 3D CAD model and NC files for the toolpaths with their relevant settings.

The concept that only minor changes are required to NC files is correct. In fact in many cases no changes are required because the CAM software keeps away from the more fancy codes, which are likely to be different. There however is the problem of who takes responsibility for changes that are made. Here the suggestion is that the changes be done by the subcontractor under approval of primary contractor, that is, the changes done in the presence of primary contractor's representative. After all these changes are small enough for this. This kind of matter will need to be addressed in a job specification up front when conducting commercial ventures in this manner.

The job specification could also specify things such as that all finishing needs to be conducted with new cutters for surface finish quality. Generally the subcontractor is responsible for including the price of cutters in the quotation. In the case where the subcontractor normally uses a different make of insert cutters, a common request is to have the correct make of insert together with its holder supplied by the primary contractor. It is advisable to go along with this request, as different makes require different parameters and these must not be changed in the NC files for fear of unpredictable problems. Built into the job specification could be a table and / or formula for adjusting maximum spindle speed and corresponding feedrate so that one can take advantage of a machine offering this improved maximum without having to approve all such changes. In this regard Pentech has an in-house feed and speed calculator program that can be used to safely affect these changes. It was found that machine shops love to have a paper drawing regardless whether they have the 3D CAD model or not. This can be added to the specification. It is probably necessary for the primary contractor to supply all workpiece material to ensure that only one grade of aluminium is used, eliminating another variable. The job specification can also include expected delivery dates but experience has shown that this will always be negotiated one-on-one.

Although one is not contracting with the CAM data directly, it was found that it is extremely helpful especially with negotiations if the primary contractor takes along a laptop computer and demonstrates the toolpaths in action on his version of, say, EdgeCAM. In fact when this was done at C.F.W. Industries they did not even wish to do dry running as both parties had the identical machine controllers.

Having machined the first identical eighth of the mould and taken the process up to the stage where subcontractors have quoted on the job it was felt that the added cost of actually machining the other seven parts in order to make the test product was not cost effective without further sponsorship from the industrial partner. It is believed that this mould making approach has been sufficiently proved.

CHAPTER 9 CONCLUSION

This work sets out to demonstrate that at least some of the large moulds used in the South African plastics industry and manufactured in Europe, could be manufactured locally by subdividing the mould halves. This has been successfully shown, certainly for the rotational moulding industry

Consider the three case studies used for this project. The pictures (figure 5.20.) of the product from the small size rotational mould prove that Pentech had both the infrastructure and required skill to make such a mould. Then using the medium size rotational mould the concept of the boss insert type subdivision is successfully demonstrated. Lastly using a large size rotational mould the contractibility of the mould segments using NC files was proved despite certain industry leaders believing that machine shops would not be interested in accepting work on the basis of NC files.

During the making of the small size rotational mould the following was discovered:

- The clamping frame concept of holding this type of work proves very successful. This is confirmed in the subsequent case studies. Also the importance of clever planning of the attachment holes is discovered.
- The splitting of parts on the clamping frame must be done with a circular toolpath.
- Many cutting parameter are determined. These are again confirmed in the subsequent case studies. Appendix B tables the most important of these.
- Due to the fine detail of this mould, the methods of working with and limitations of very small diameter cutters was discovered in this case study, see section 5.9 for more detail.
- Flanges must be finish cut last to get sharp corners on the edge of the mould cavity.
- The importance of completing all the CAM work before the starting any cutting is discovered. Upstream choices can cause downstream problems. First look at the whole river before jumping in.
- The need for a new coolant is discovered. Pentech now uses Castrol Alusol B as the coolant of choice.
- The methods of rough cutting the reverse side are established. Pentech standardizes on Seco Turbo Mill and Copy cutters for this job at a depth of cut of 2mm and a chip load of 0.15mm/rev/flate.

After completing the small size rotational mould it was realized that further investigation of surface finish was necessary. The surface finish experiment showed that Alu-Power, X-Power, and Tungsten Carbide cutters gave the best surface finish, with the Tungsten Carbide cutters winning hands down on cost.

During the making of the medium size rotational mould the following was discovered:

- A better correlation is achieved between simulations times given in EdgeCAM and the actual cutting time.
- A material saving of almost 50% was achieved in this case study just as a result of the subdivision alone.
- By choosing the boss insert type subdivision opportunities for CNC turning parts has been created. This opened up the opportunity of collaboration with a neighbouring technical training institution, namely Bellville Technical College. This also led to the first concurrent parts being made.
- Good lead-in / lead-out settings in toolpaths are determined by means of an experiment to prevent the cusp marks that can be evident from this phenomenon.

During the making of the large size rotational mould the following was discovered:

- The concept of completing the reverse side first below starting the product side is discovered.
- The need to finish all roughing, then unclamp the part and allow it to settle is discovered. This is only necessary on very large parts where distortion is very commonplace.
- The egg box design appearance of the reverse side is developed for this case study.
- Subcontracting demands laptop simulations on Pentech's version of EdgeCAM, a job specification pinning down responsibilities and expectation, the use of dry runs where any NC file header or tail is altered to suit a particular make of CNC machine controller. The minor extent of these alterations is demonstrated. In fact often these are not even required.
- A mechanism has been developed for dealing with the maximum spindle speed variation from machine to machine, to ensure one still uses maximum benefit.

Where to from here? The next step would be a full-scale commercial venture. This would need an industrial partner, such as Atlas Plastics, to commit the necessary funds to the venture. It is recommended that all parties recognize the potential difficulty regarding delivery time scales, as pilot projects generally require considerably more time and effort than originally anticipated. It is also understandable, that industry's urgency often increases together with their level of funding. It is therefore imperative that an agreed process is put in place where upon all parties can monitor progress and assist in overcoming any problems as these are encountered. This will assist in alleviating necessary tensions arising from differing expectations and the inevitable hurdles that occur during research and development. It is therefore strongly recommended that this be planned in any future work.

REFERENCES

1. Alliance of Rotational Moulding Organisations,
http://www.rotationalmoulding.com/how_does_rotational_moulding_work.htm,
Process Page
2. Arslan, M.C., Catay, B. and Budak, E (2004), **A decision support system for machine tool selection**, Journal of Manufacturing Technology Management, Vol. 15, No. 1, pp. 101-109.
3. Association of Rotational Molders International,
<http://www.rotomolding.org/i4a/pages/index.cfm?pageid=3320>, About Rotomolding Page
4. Bozarth, C. and Chapman, S. (1996), **A contingency view of time-based competition for manufacturers**, International Journal of Operations & Production Management, Vol. 16 No. 6, pp.56-57
5. British Plastics Federation,
http://www.bpf.co.uk/bpfindustry/process_plastics_Rotational_Moulding_1.cfm
Process Plastics Rotational Moulding 1 Page
6. Cagliano, R. and Spina, G. (2002), **A comparison of practice-performance models between small manufacturers and subcontractors**, International Journal of Operations & Production Management, Vol. 22 No. 12, pp. 1367-88.
7. Crawford, R.J. (Ed.) (1996), **Rotational Moulding of Plastics**, 2nd ed., Research Studies Press Ltd and John Wiley & Sons Inc.
8. Crawford, R.J. and Kearns, M.P. (2003), **Practical Guide to Rotational Moulding**, Rapra Technology Limited
9. Drotzky, J.G. and Terblanche, J.P. (1993), **Mechanical Engineering Design**, Tech Books, pp.57, 135 and 138
10. Eumach Co. Ltd. (1995), **Eumach Vertical Machining Center Series Catalogue**
11. Fireman, J. (1991), **Lead Time and cost Reduction: A CNC Programming System for Motor Vehicle Prototypes**, Integrated Manufacturing System, Vol. 2, No. 3.
12. Gieck K. and Gieck R. (1996), **Technical Formulae 8th Edition**, Gieck Verlag, pp P1
13. Gogos, G., Olson, L.G., Liu, X. and Pasham, V. (1997), **Numerical modelling for rotational moulding of thermoplastics**, Proceedings of the ASME Heat Transfer Division, Vol. 1, pp. 113-119.

14. Gogos, G., Olson, L.G., Liu, X. and Pasham, V. (1997a), **Computational model for rotational moulding of thermoplastics**, SPE ANTEC. Technical Papers 21.
15. Gogos, G., Olson, L.G., Liu, X. and Pasham, V. (1997b), **A model for rotational moulding of thermoplastics**, Transactions of the North American Manufacturing Research Institution of the Society of Manufacturing Engineers, Vol. 25, pp. 13-17.
16. Gogos, G., Olson, L.G., Liu, X. and Pasham, V. (1998), **New model for rotational moulding of plastics**, Polymer Engineering and Science, Vol. 38 No. 9, p 1387-1398.
17. Gogos, G., Liu, X. and Olson, L.G. (1999), **Cycle time predictions for the rotational moulding process with and without mould/part separation**, Polymer Engineering and Science, in press.
18. Grawford, R.J. and Keams, M.P. (2003), **Practical Guide to Rotational Moulding**, Rapra Technology Limited.
19. Handfield, R.B. (1994), **Effects of concurrent engineering on make-to-order products**, IEEE Transactions on Engineering Management, Vol. 41 No. 4, pp. 384-93.
20. Kaufman, A., Wood, C.H. and Theyel, G. (2000), **Collaboration and technology linkages: a strategic supplier typology**, Strategic Management Journal, Vol.21, pp.649-63
21. Lyons, B.R. and Bayley, S. (1993), **Small subcontractors in UK. Engineering: competitiveness, dependence and problems**, Small Business Economics, No.2.
22. Maffin, D. and Braiden, P. (2001), **Manufacturing and supplier roles in product development**, International Journal of Production Economics, Vol. 69, pp. 205-13.
23. Meredith, J. (1987), **The strategic and advantage of new manufacturing technology for small firms**, Strategic Management Journal, Vol.3.
24. Mitchell, W.P., (2002), **Distributive Mould Making**, RAPDASA Conference 2002
25. Nugent, P.J. (1990), **Theoretical and experimental studies of heat transfer during rotational moulding of plastics**, PhD. Thesis, Queen's University, Belfast.
26. Nugent, P.J., Crawford, R. J. and Xu, L. (1992), **Computer prediction of cycle times during rotational moulding of plastics**, Advances in Polymer Technology, Vol. 11 No. 3, pp. 181-191.

27. Patel, S., Dale, B.G., Shaw, P (2001), **Set-up time reduction and mistake proofing methods: an examination in precision component manufacturing**, The TQM Magazine, Volum 13; No. 3, pp. 175-79.
28. Prasad, B. and Fujun, W. (1998), **A concurrent workflow management process for integrated product development**, Journal of Engineering Design, Vol. 9 No. 2, pp. 121-36.
29. Rao, M.A. and Thorne, J.L. (1972), **Principles of rotational moulding**, Polymer Engineering and Science, Vol. 12 No. 4, July, pp. 237-64.
30. Samadhi, T.M. A. A. and Hoang, K. (1995), **Shared computer-integrated manufacturing for various types of production environment**, International Journal of Operations & Production Management, Vol. 15 No. 5, pp. 95-108.
31. Seco Tools AB (2000), **Technical Guide**
32. Seco Tools AB (2000), **Milling Catalogue**
33. Sprague, R.A, Singh, K.J. and Wood, R.T. (1991), **Concurrent engineering in product development**, IEEE Design and Test of Computer, Vol.81, March, pp. 6-13.
34. Sun, D.W. and Crawford, R.J. (1993), **Analysis of the effects of internal heating and cooling during the rotational moulding of plastics**, Polymer Engineering and Science, Vol. 33 No. 3, February, pp. 132-9.
35. Tersine, R.J. and Hummingbird, E.A. (1995), **Lead-time reduction: the search for competitive advantage**, International Journal of Operations & Production Management, Vol. 15, No. 2, pp. 8-18.
36. Throne, J.L. (1976), **Rotational moulding heat transfer and update**, Polymer Engineering and Science, Vol. 16. No.4, April, pp. 257-64.
37. Timings R.L. (1992), **Manufacturing Technology Volume 1 Second Edition**, Longman /scientific & Technical, pp. 76
38. ToolQuip & Allied (2004) **YG Power End Mills Catalogue**
39. Veness, P.J., Chidolue, G. and Medhat, S.S. (1996), **Concurrent engineering infrastructure: tools, technologies and methods in British industry**, Engineering Management Journal, June, pp. 141-7.

APPENDIX A - ATLAS PLASTICS LETTER

atlas plastics (PTY) LTD

ATLAS PLASTICS – ROTO MOULDING

Reg. No. 1975002568/07
 Vat Reg. No. 4500103454
 31 Neutron Road, Uraniaville
 P O Box 850, Klerksdorp 2570
 Tel (018) 469 1201
 Fax (018) 469 3691
 E-Mail gary@atlasplastics.co.za

27 October 2004
 Peninsula Technikon
 Skiereiland

To Whom It May Concern:

Mr. Wanjun Li visited our factory on 26th & 27th October 2004, in order to test an aluminium mould, which he had CNC machined from a drawing supplied by Atlas Plastics.

On receiving the mould it was inspected for:

1. Overall appearance of flange closure.
2. Porosity of material, neatness and accuracy of machining.
3. Parting lines and alignment of top and bottom section.

We were very impressed with the quality and finish of the mould – more particularly the inside finish. No modifications or improvement were made to the mould other than the introduction of a
 "VENT".

A cage was then fitted for a rotational moulding machine. Power was introduced and mould closed. No leaks were observed. We monitored the moulding process using "TempLogga". The heat transfer was very good and the product moulded evenly. Due to the fact that the bottom section of the mould was made in sections special attention was given to the quality of the joint line, which was found to be very good.

In conclusion the mould was very well made, tolerances very good, with an excellent finish. Thus we were able to produce an excellent product namely a Steering Wheel from the first cycle. I have believed for a few years now that this is a good method of constructing a Rotational Moulding Mould and I am now more convinced than ever before.

Yours faithfully,

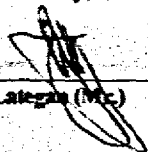
 Gary Lategan (M.C.)

Branches:

BLOEMFONTEIN, CAPE TOWN, DURBAN, JOHANNESBURG, PORT ELIZABETH

Directors: G Lategan P Lategan R Lategan

Figure A1. Letter from the industrial partner company on their assessment of the medium size steering wheel mould produced

APPENDIX B - CUTTER DATA

The following table shows all the material groups classified by the Seco Company. The same Seco insert will have different cutting speeds according to different material groups. For example, a F30M insert used in a Ø10mm MiniMaster has the parameter $V_C=175\text{m/min}$ for group 5 (normal tool steel), but $V_C=830\text{m/min}$ for group 17 (aluminium). In this project, only material from group 17 (aluminium) is used. So all the Seco cutters and inserts used in this project have their spindle speeds and feedrates based on material group 17's linear tip velocity V_C and chip load d .

Table B-1: Seco material group classifications

	Steel
1	Very soft low-carbon steels. Low carbon and purely Ferritic mild steels.
2	Free cutting steels, excluding stainless steels.
3	Machines steels and carbon steels. Plain carbon steels with low to medium carbon content (<0.5%C).
4	High-carbon and ordinary low-alloy steels. Medium-hard quenching and tempering steels. High-carbon steels (>0.5%C). Ferritic and martensitic stainless steels.
5	Normal tool steels. Harder quenching and tempering steels. Martensitic stainless steels.
6	Difficult tool steels. High-alloy, high-hardness steels. Martensitic stainless steels.
7	Difficult high-strength, high-hardness steels. Hardened steels from material groups 3–6. Martensitic stainless steels.
	Stainless steels
8	Easy-cutting stainless steels. Free-cutting stainless steels. Calcium-treated stainless steels.
9	Moderately difficult stainless steels. Austenitic and duplex stainless steels.
10	Difficult stainless steels. Austenitic and duplex stainless steels.
11	Very difficult stainless steels.

	Austenitic and duplex stainless steels.
	Cast iron
12	Moderately hard cast iron. Grey iron.
13	Low-alloy cast iron. Malleable cast iron. SG iron.
14	Moderately difficult alloy cast iron. Moderately difficult malleable iron. SG iron.
15	Difficult high-alloy cast iron. Difficult malleable iron. SG iron.
	Other materials
16	Non-ferrous alloys. Aluminium with <16% Si. Brass, zinc and magnesium.
17	Non-ferrous alloys. Aluminium with >16% Si. Aluminium, bronze and copper-nickel.
20	Nickel-, cobalt- and ferrous superalloys with hardness of <30 Rc. Incoloy 800 and Inconel 601, 617 and 625. Monel 400.
21	Nickel-, cobalt- and ferrous superalloys with hardness of >30 Rc. Inconel 718 and 750-X and Incoloy 925, Monel K-500.
22	Titanium-based alloys. Ti-6Al-4V

Table B-2: Cutter parameters specifically for aluminium.

Cutter type (mm)	Cutting speed V_c (m/min)	Chip load d (mm/rev/flute)	Max Depth of Cut a_p (mm) (when $a_p/D=100\%$)
Seco Ø63 face cutter	1020, 775, 655	0.10, 0.25, 0.40	5
Seco Ø40 copy cutter	865	0.15	3
Seco Ø20 turbo mill	785, 660, 565	0.06, 0.12, 0.20	3
Seco Ø16 turbo mill	835, 720, 620	0.04, 0.08, 0.14	3
Seco Ø10 MiniMaster	950	0.14	1
X-power	200	0.03	Up to 0.5 x Diameter
Alu-power	350	0.03	Up to 0.5 x Diameter
Tungsten carbide	150	0.03	Up to 0.5 x Diameter
HSS (Ballnose, Endmill)	90	0.02	Up to 0.2 x Diameter
HSS (driller)	90	0.08	Depth of the hole

APPENDIX C - MACHINE SPECIFICATIONS

C.1. PENTECH'S MC-800P EUMACH VERTICAL CNC MACHINING MACHINE

The CNC machine at workshop of mechanical engineering department was used to do most of the machining job in the project.

The following is a picture of the CNC machine.

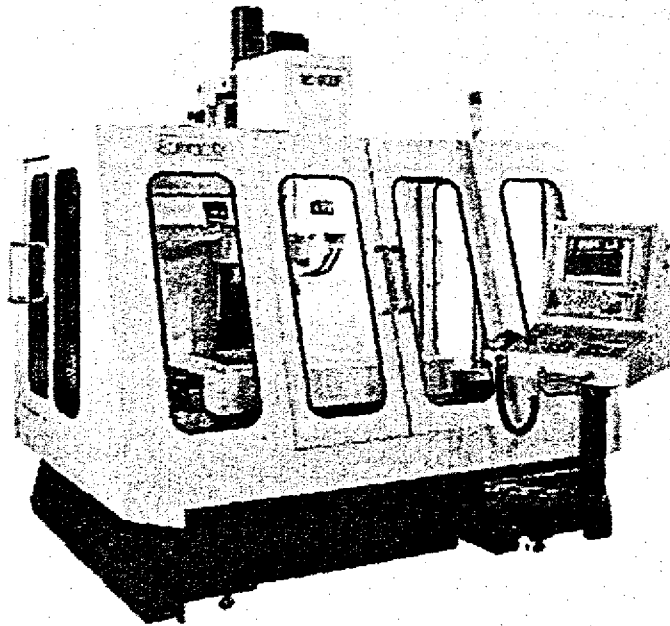

Figure C1. Pentech's Eumach CNC milling machine

C.2. SOME CHARACTERISTICS OF THE MACHINE

The floor type full guarding system provides a chip free working environment; an interlocked safety device on the doors stops the machine immediately whenever the doors are opened.

The updated "P-TYPE" AC spindle motor gives a higher torque output over a much wider range. The maximum spindle speed is 6000 R.P.M and the horsepower can reach 9kw/11kw (12HP/15HP), which enables this machine to perform heavy-duty machining easily.

The CNC control system for this machine is Fanuc OMC

C.3. SPECIFICATION OF MACHINE'S CONTROLLER IN COMPARISON WITH THE MITSUBISHI-M520AM

- O Standard specification
 Δ Option specification
 — Undefined specification

Table C-1: Comparison between Mitsubishi and Fanuc control system

Items	Mitsubishi-M520AM	Fanuc-OMC
Maximum control axes 3 axis	O	O
4 axis	Δ	Δ
5 axis	Δ	—
Simultaneous control axis 3 axis	O	O
4 axis	Δ	Δ
5 axis	—	—
Inch/Metric conversion	O	O
Absolute/Incremental command	O	O
Rapid override F0, 25, 50, 100	O	O
Helical interpolation	O	O
Rigid tapping (Synchronous tapping)	O	Δ
Backlash compensation	O	O
Pitch error compensation	O	O
Memory capacity 80M (32k byte)	O	O
120M (48k byte)	—	Δ
160M (64k byte)	Δ	—
320M (128k byte)	Δ	Δ
Background edition	O	O
Clock function	O	O
Tape mode & DNC function (RS 232C)	O	O
9" CRT compact monochrome display	O	O
Tool length offset G43, 44, 49	O	O
Tool radius offset G41, 42, 40	O	O
Tool offset memory number	200	99
Machine coordinate system G53	O	O
Work coordinate system select G54~G59	O	O
Local coordinate system setting G52	O	O
Mirror image	O	O
Special fixed cycle G34~G37.1	O	—
Circular cutting G12, G13	O	O
Play back	O	O
Skip function G31	O	O
Manual tool length measurement	O	Δ
Program restart function	O	O
External alarm messages	O	O
Ladder monitor	O	O
2 nd reference point return	O	O

English display	O	O
Chinese/Japanese display	Δ	Δ
German/French display	Δ	Δ
Korea/Italia/Spanish display	—	Δ
Custom Marco	O	O
Coordinate system rotation	Δ	Δ
Scaling	Δ	Δ
4 th axis function	Δ	Δ
Tool path graphic display	O	Δ
Polar coordinate command	—	Δ
Spiral interpolation	Δ	—

C.4. SPECIFICATION OF PENTECH'S EUMACH MC800P CNC MILLING MACHINE

Table C-2: Specification of Pentech's CNC milling machine

X/Y/Z Travel	800MM/510/510
Spindle nose to table	140-650
Spindle centre to column surface	520
Table working area	1200MM x 635MM
T slots (Width x Number x distance)	18MM x 5 x 100MM
Table maximum loading	500KGS
Spindle motor power	9KW
Spindle speed	60-6000RPM
Spindle taper	BT-40
Spindle bearing class	P4
XYZ motor power	1.8KW
XYZ motor torque	120KG-CM
XYZ rapid feed	12M/MIN
Cutting feedrate	1-5000MM/MIN
Minimum setting	0.001MM
Ball screws (diameter x pitch)	40MM x 10MM
Machine weight	5500KGS
Floor space required	3320MM/2500MM/2670MM
Coolant pump power	0.375KW
Lubrication pump power	4WATT
Power consumption	20KVA
Number of ATC tools	24
Maximum tool (diameter/weight/length)	80MM/7KGS/300MM
Repeatability accuracy	±0.003MM
Positioning accuracy	±0.003MM/300MM

APPENDIX D - THE DIFFERENCE BETWEEN TWO EDGECAM POST PROCESSOR OR CGD FILES

EdgeCAM uses different code generators to generate different G codes to match different CNC machines needs. The most popular CNC machine control systems are Fanuc system and Mitsubishi system. EdgeCAM's CGD file is the Code Generator Document file, which can be compiled in the EdgeCAM code wizard. From the code wizard, the different CNC machine post processor files, namely MCP files, are then available inside EdgeCAM.

There are two different CGD files are being used by the staff in Pentech's workshop, namely **pentech.cgd** and **wm.cgd**. The parameters differences needed to be investigated in order to find out if there was any serious implication on the quality of jobs done using each.

Machine parameters differences

	Pentech.cgd	Wm.cgd
Maximum rapid rate	12000 mm/min	6000 mm/min
Maximum high feedrate	5000 mm/min	2000 mm/min
Radius compensation factor	1.5	1

Turret position is different:

	Pentech.cgd	Wm.cgd
Turret position	X224Y112Z60	X200Y200Z400
Tool home	X0Y0Z330	X0Y0Z330

Format table

Wm.cgd does not has the force '0' on integers

Pentech.cgd has the force '0' on integers

Minimum movement millimetres

Wm.cgd 0.001mm,

Pentech.cgd 0.005mm

Block numbers

	Pentech.cgd	Wm.cgd
Number increment	10	2
Output safe/tool change block	Yes	No

Use radius when possible in circular interpolation

Wm.cgd yes

Pentech.cgd no

Start Subroutines number

Wm.cgd 8000

Pentech.cgd no

Program start and program end codes are different

Wm.cgd:

Program start:

```
[PROGID] ([PARTNAME][SEQUENCENAME])
(CUT TIME=[CYCLETIME] MIN)
(NO RAD COMP)
[DELETE][BLKNUM]G90 G55
```

Program end:

```
[DELETE][BLKNUM] M05
[DELETE][BLKNUM] M09
```

```
[DELETE][BLKNUM] M20
```

```
[DELETE][BLKNUM] M30
```

```
%
```

Pentech.cgd:

Program start:

```
%
[PROGID]
([PROGDESCR])
[DELETE][BLKNUM][UNITSGCODE] G90 G40G55
```

Program end:

```
[DELETE][BLKNUM] G00[ZHOME] M09
```

```
[DELETE][BLKNUM] Z0 H00 M19.
```

```
[DELETE][BLKNUM] M30
```

```
%
```

Rapid to home program is different:

Wm.cgd [DELETE][BLKNUM] G28 Z0 H0

Pentech.cgd [DELETE][BLKNUM] G28 Z0 H0 M19

Tool change is different:

Wm.cgd:

```
[DELETE][SAFEBLKNUM] [TURRETNO] M06
[DELETE][BLKNUM]([USER STRING 1]=[TOOLDESCR]
[TOOLDIAM])
[DELETE][BLKNUM][SPEED][SPINDIR]
```

Pentech.cgd:

```
[DELETE][BLKNUM] G28 G91 Z0
```

```
[DELETE][BLKNUM] G28 X0 Y0
```

```
[DELETE][BLKNUM] G90
```

```
[DELETE][SAFEBLKNUM][TURRETNO] ([COMMENT])
```

```
[DELETE][BLKNUM][WORKGCODE] M06
```

```
[DELETE][BLKNUM][NEXTTOOL] M01
```

```
[DELETE][BLKNUM][SPEED][SPINDIR][GEARMCODE]
[COOLANT ON]
```

Work datum shifting

Wm.cgd no

Pentech.cgd yes

The code block:

```
[DELETE][BLKNUM] G10 L2
```

```
[WORKREGISTER][XABSORIGIN][YABSORIGIN][ZABSORIGIN]
```

```
[(CPLNAME)]
```

The other difference between two cgd files:

Wm.cgd uses the radius system when cutting a circle, while the **Pentech.cgd** uses the I, J system to cut a circle.

The setting of cutting a circle is at 'NC style', → 'Circular interpolation'.

The differences as listed above are largely a matter of preference and not of large impact on the requirements of the machine. Thus both versions of the post processor can happily be used.

APPENDIX E - DATA FILE CD

The CD found in the folder on the back cover of this document contains all CAD and CAM files as well as any other electronic copies of data relating to this project.