



Cape Peninsula  
University of Technology

**The application of Sr-spec resin in the analysis of  $^{90}\text{Sr}$  in effluent and environmental samples at KNPS**

by

**GLEDUS VISSER**

**Thesis submitted in fulfilment of the requirements for the degree**

**Master of Technology (CHEMISTRY)**

**in the Faculty of APPLIED SCIENCES**

**at the Cape Peninsula University of Technology**

**Supervisor:** Prof. Nico van der Walt

**Bellville Campus**

**Date submitted (January 2016)**

**This thesis is the copyright of the  
Cape Peninsula University of Technology  
and may not be published or reproduced  
without prior permission from the university.**

## DECLARATION

I, Gledus Visser, declare that the contents of this dissertation/thesis represent my own unaided work, and that the dissertation/thesis has not previously been submitted for academic examination towards any qualification. Furthermore, it represents my own opinions and not necessarily those of the Cape Peninsula University of Technology.

**Signed:**

---

**Date:**

---

## ABSTRACT

Radiostrontium ( $^{90}\text{Sr}$  and  $^{89}\text{Sr}$ ) has been released to the environment by global fall-out following atmospheric nuclear explosions, by waste discharges and fall-out from the Chernobyl.  $^{89}\text{Sr}$ , with a half-life of 50.5 days, quickly decays to undetectable levels, while  $^{90}\text{Sr}$  is radiobiologically more important because of its longer half-life of 28.78 years, and because it behaves chemically similar to Ca, and accumulates in bones and teeth. Cost effective and relatively simple procedures for determination of radiostrontium are desirable.

An accurate determination of radionuclides from various sources in the environment is essential for assessment of the potential hazards and suitable countermeasures both in case of accidents, authorised releases and routine surveillances. Reliable radiochemical separation and detection techniques are needed for accurate determination of alpha and beta emitters. Rapid analytical methods are needed in case of an accident for early decision-making.

At the Koeberg Nuclear Power Station (KNPS),  $^{90}\text{Sr}$  analysis are performed on liquid effluent samples making use of the traditional fuming nitric acid method, and subsequent counting of particulate samples on an alpha/beta proportional counter. This method is often at times very time – consuming, and involves many precipitation steps. The use of fuming nitric acid is also very dangerous and could lead to severe personnel injuries in the event of an accident. This project focussed on the application of Sr-Spec resin in the analysis of  $^{90}\text{Sr}$ . This work presents the methods for  $^{90}\text{Sr}$  analysis for both effluent samples as well as environmental samples. This research also focussed on the calibration of the different radiometric instruments, which are the Liquid Scintillation Counter, the Alpha/Beta Counter as well as the Gamma Detector.

## ACKNOWLEDGEMENTS

### **I wish to thank:**

- Prof Dr Nico van der Walt, for his guidance, patience, and encouragement.

## **DEDICATION**

To my daughter Naledi, this is for you.

# Table of Contents

DECLARATION.....	ii
ABSTRACT.....	iii
ACKNOWLEDGEMENTS.....	iv
DEDICATION.....	v
GLOSSARY.....	viii
ABBREVIATIONS.....	ix
CHAPTER 1 INTRODUCTION.....	1
1.1 Nuclear Power plants – an overview .....	1
1.2 Environmental pollution .....	7
1.2.1 Nuclear weapon tests.....	7
1.2.2 Chernobyl accident .....	7
1.2.3 Radioactive discharges .....	7
1.2.4 Waste management at nuclear facilities .....	7
1.3 Strontium and the importance of its analysis .....	10
Other Fission Products as environmental contaminants .....	12
1.3.1 The search for selective separation agents for strontium.....	16
1.3.2 Typical Crown Ether.....	17
CHAPTER 2 LITERATURE REVIEW .....	19
2.1 Traditional fuming nitric acid method: .....	19
2.2 Ion exchange chromatography.....	21
2.3 Solvent extraction .....	22
2.3.1 HDEHP (bis (2-ethylhexyl) phosphoric acid).....	22
2.3.2 TBP (tri-n-butylphosphate) .....	22
2.3.3 TTA (thenoyltrifluoroacetone).....	22
2.3.4 Other extractants.....	23
2.4 Extraction chromatography .....	23
2.5 Sample Preparation– Environmental samples .....	29
2.5.1 Sample Digestion .....	29
2.5.1.1 Dissolution.....	29
2.5.2 Sample Preparation – Liquid Samples.....	32
CHAPTER 3 INSTRUMENTATION.....	33
Gamma spectroscopy detectors.....	33
3.1.1 Gamma ray characteristics.....	36
3.1.2 System components and principle of operation .....	37
3.1.3 Detector performance .....	38
Liquid Scintillation Counting .....	42
3.2 iMatic™ Gas-less Automatic Alpha/Beta Counting System .....	49
3.2.1 Description .....	49
3.2.2 Features.....	50
CHAPTER 4 EXPERIMENTAL .....	52
4.1 Calibration of instruments - HPGe Gamma Detector.....	52
4.1.2 Calibration of iMATIC alpha/beta detector.....	52
4.1.3 Calibration of Beckman Liquid Scintillation Counter.....	53
4.2 Alternative quench calibration for <sup>90</sup> Sr and <sup>90</sup> Y measurements.....	54
Experimental.....	55
4.3 Determination of total Sr in liquid effluent samples .....	55
4.3.1 Apparatus .....	55
4.3.2 Reagents .....	55
4.3.3 Preparation of water samples.....	55
4.3.4 Sr – Resin column preparation.....	56
4.3.5 Sr- Resin Column Separation.....	56
4.3.6 Counting of Samples .....	56
4.4 Determination of Total Sr in Environmental samples.....	57
4.4.1 Apparatus .....	57

4.4.2	Reagents.....	57
4.5	Preparation of Environmental samples .....	58
	Separation .....	59
4.6	Extraction.....	59
4.7	Method Validation.....	61
4.7.1	Environmental Samples .....	61
4.7.2	Effluent samples.....	61
CHAPTER 5 – RESULTS AND DISCUSSION .....		63
5.1	Calibrations.....	63
5.1.1	Gamma Detector.....	63
5.1.2	Calibration of Matic.....	63
5.1.3	Calibration of Liquid Scintillation Counter .....	63
5.2	Environmental samples.....	64
5.3	Effluent samples.....	66
CHAPTER 6 CONCLUSION .....		67
CHAPTER 7 REFERENCES.....		69
APPENDICES .....		74
Fig.20.	Mixed Gamma Standard Preparation.....	74
Fig.21.	Gamma Source Certificate.....	75
Fig.22.	Energy Calibration Curve .....	76
Fig.23.	Efficiency Calibration Report.....	77
Fig.24.	Efficiency Calibration Report.....	78
Fig.25.	Efficiency Calibration Record .....	79
Fig.26.	Beta Standard Certificate of Calibration.....	80
Fig 27.	Matic Efficiency Calibration Report .....	81
Fig.28	<sup>90</sup> Sr Analysis report using Fuming nitric acid method .....	92
Fig.29.	<sup>90</sup> Sr Analysis report using Sr-Spec Resin .....	93
<b>List of Figures in text</b>		
Fig.1.	The Nuclear Fuel Cycle [www.world-nuclear.org].....	4
Fig.2.	Sr-90 Fission Decay Chain.....	11
Fig.3.	Radioactive Decay .....	14
Fig.4.	Crown Ethers.....	17
Fig 5.	Light-switching crown ether.....	28
Fig.6.	Sr- Spec Resin .....	35
Fig.7.	Acid Dependency for various ions.....	38
Fig 8.	HPGe Detector Operational Characteristics - Cryostat and Dewar .....	44
Fig.9	Typical Gamma Ray Spectrum Output. ....	45
Fig.10	The gamma ray spectrum of natural uranium .....	46
Fig.11.	Electrically cooled Gamma detector in a lead castle .....	50
Fig.12.	Liquid Nitrogen cooled Detector in a lead castle.....	51
Fig.13.	Detector inside of lead castle .....	51
Fig.14.	The Scintillation Process .....	53
Fig.15.	Compton Spectrum .....	55
Fig.16.	<sup>3</sup> H/ <sup>14</sup> C Quench Curve .....	56
Fig.17.	<sup>3</sup> H/ <sup>14</sup> C Quench Curve .....	56
Fig.18.	LS 6500 Multipurpose Liquid Scintillation Counter. ....	58
Fig.19.	IMatic alpha beta counter as used at KNPS .....	61
Fig.30	Environmental samples .....	75
Fig.31	Effluent samples.....	76
Fig.32.	Vacuum Box System .....	78
<b>List of Tables</b>		
Table 2.1	Resins commercially available from Eichrom Technologies .....	34
Table 6.1	Environmental samples.....	74
Table 6.2.1	Effluent samples.....	76

## GLOSSARY

- **ALPHA PARTICLE ( $\alpha$ -particle)** particle consisting of two protons plus two neutrons (the nucleus of a helium atom) emitted by a radionuclide
- **ANTHROPOGENIC** - Man made radionuclides
- **BETA PARTICLE ( $\beta$ -particle)** – An electron or positron which has been emitted by an atomic nucleus or neutron in nuclear transformation
- **BIOLOGICAL HALF-LIFE** – The time it takes for half the activity to be expelled from the body.
- **DECAY** – the process of spontaneous transformation of a radionuclide or the decrease in radioactivity of a radioactive substance as a result of this process
- **DECAY PRODUCT** - A nuclide or radionuclide produced by decay. It may be formed directly from decay of a radionuclide or as a result of a series of decays through several radionuclides, sometimes referred to as progeny or daughters.
- **ESL** – Environmental Survey Laboratory
- **FALL-OUT** – Airborne radioactive material from the testing of nuclear weapons or nuclear accidents deposited on the earth's surface.
- **FISSION** – The division of heavy nucleus into two parts with masses of equal order of magnitude, usually accompanied by the emission of neutrons and gamma radiation
- **FISSION PRODUCT** – Nuclides produced by nuclear fission or by the subsequent radioactive decay of the nuclides thus formed
- **GAMMA RADIATION** – Penetrating electromagnetic radiation emitted by an atomic nucleus during radioactive decay and having wavelengths much shorter than those of visible light
- **HALF-LIFE** – For a radionuclide, the time required for the activity to decrease, by a radioactive decay process, by half. Symbol  $t_{1/2}$
- **HTM** – Hard to measure (radionuclides)
- **IAEA** – International Atomic Energy Agency
- **KNPS** – Koeberg Nuclear Power Station
- **LSC** – Liquid scintillation counting
- **NORM** – Naturally occurring radioactive materials.
- **RADIOACTIVITY** – The phenomenon whereby atoms undergo spontaneous random disintegration, usually accompanied by the emission of radiation.
- **RADIONUCLIDES** – A radioactive nuclide
- **Sr-Spec** – Strontium specific resin (Sr-Resin)

## ABBREVIATIONS

<b>ALARA</b>	As Low As Reasonably Achievable
<b>CMPO</b>	Octylphenyl-N,N-di-isobutyl cabamoylphosphine oxide
<b>DCH<sub>18</sub>C<sub>6</sub></b>	4,4'(5)-di-t-butylcyclohexano-18-crown-6
<b>DTPA</b>	Diethylene-triamine-pentaacetate
<b>DPM</b>	Disintergrations per minute
<b>HDEHP</b>	Bis(2-ethylhexyl)phosphoric acid
<b>INSAG</b>	International Nuclear Safety Group
<b>PTFE</b>	Polytetrafluroethylene
<b>Sv</b>	Sievert
<b>TALSPEAK</b>	Trivalent Actinide – Lanthanide Separation by Phosphorous Reagent Extraction from Aqueous Complexes.
<b>TBP</b>	Tributyl Phosphate
<b>TNOA</b>	Tri-n-octylamine
<b>TOPO</b>	Tri-n-octylphosphine oxide
<b>TTA</b>	Thenoyl-trifluroacetone
<sup>241</sup> <b>Am</b>	Americium - 241
<sup>14</sup> <b>C</b>	Carbon - 14
<sup>60</sup> <b>Co</b>	Cobalt - 60
<sup>137</sup> <b>Cs</b>	Cesium - 137
<sup>152</sup> <b>Eu</b>	Europium - 152
<sup>3</sup> <b>H</b>	Tritium
<sup>90</sup> <b>Kr</b>	Krypton - 90
<sup>238</sup> <b>Pu</b>	Plutonium - 238
<sup>239</sup> <b>Pu</b>	Plutonium - 239
<sup>240</sup> <b>Pu</b>	Plutonium - 240
<sup>241</sup> <b>Pu</b>	Plutonium - 241
<sup>90</sup> <b>Rb</b>	Rubidium - 90
<sup>90</sup> <b>Sr</b>	Strontium - 90
<sup>238</sup> <b>U</b>	Uranium - 238
<sup>90</sup> <b>Y</b>	Yttrium - 90
<sup>65</sup> <b>Zn</b>	Zinc - 65

## CHAPTER 1 INTRODUCTION

### 1.1 Nuclear Power plants – an overview

Nuclear power plant safety requires a continuing quest for excellence. All individuals concerned need constantly to be alert of opportunities to reduce risks to the lowest practicable level. The quest is most likely to be fruitful if it is based on an understanding of the underlying objectives and principles of nuclear safety, and the way in which its aspects are interrelated.

Three safety objectives are defined for nuclear power plants. The safety objectives are not independent; their overlap ensures completeness and adds emphasis.

#### **General nuclear safety objective:**

- To protect individuals, society and the environment by establishing and maintaining in nuclear power plants an effective defence against radiobiological hazards.
- Each viable method of production of electricity has unique advantages and possible detrimental effects. Radiobiological hazard means adverse health effects of radiation on both plant workers and the public, and radioactive contamination of land, air, water or food products.

#### **Radiation protection objective:**

- To ensure in normal operation that radiation exposure within the plant and any release of radioactive material from the plant is as low as reasonably achievable, and below prescribed limits, and to ensure mitigation of the extent of radiation exposure due to accidents.

#### **Technical safety objective:**

- To prevent with high confidence accidents in nuclear power plants, to ensure that, for all accidents taken into account in the design of the plant, radiological consequences, if any, would be minor, and to ensure that the likelihood of severe accidents with serious radiobiological consequences is extremely small.

#### **Fundamental principles – Safety culture:**

- An established safety culture governs the actions and interaction of all individuals and organisations engaged in activities related to nuclear power. Safety culture refers to the personal dedication and accountability of all individuals engaged in an activity which has a bearing on the safety of nuclear power plants.

### **Responsibility of operating organisation:**

- The ultimate responsibility for the safety of a nuclear power plant rests with the operating organisation. The operating organisation is in complete charge of the plant with full responsibility and authority for approved activities and the production of electric power. Since these activities also affect the safety of the plant, the operating organisation establishes policy for adherence to safety requirements, establishes procedures for the safe control of the plant under all conditions, including maintenance and surveillance and retains a competent, fit and fully trained staff. <sup>[1]</sup>

Nuclear power plants are required to have effluent and environmental monitoring programs to ensure that the impact from nuclear power plant operations are minimised.

They are required to limit the concentrations of radionuclides that may be released into the environment to levels that are as low as reasonably achievable (ALARA). All radioactive airborne and liquid discharges from nuclear plants are monitored.

To demonstrate that nuclear plants are within regulatory limits, environmental samples including the surrounding soil, vegetation, cow's milk and water samples are analysed on a regular basis.

At KNPS, the pathways used to measure the effect of the operation of Koeberg on the environment, is to sample surrounding soil, vegetation and milk from neighbouring farms, sea water, marines, surface water and air samples.

The importance of various exposure pathways depends on:

- The radiological properties of the material released, i.e. gamma emitters, beta emitters or alpha emitters, as well as physical half-life;
- The physical state, i.e. gas, liquid or solid; chemical state, organic or inorganic; properties of the material and its migration characteristics;
- The dispersal mechanism and factors affecting it, i.e. stack height, meteorological conditions; environmental characteristics
- The locations, ages, diets and habits of the exposed individuals or population.

Under conditions of normal discharges, the exposure pathways are usually permanent and well defined. In the case of emergency releases, the contributions via different pathways to the doses received by workers and the public may be different from the normal and transient. These differences should be considered when establishing the emergency monitoring programme. In order to protect the public and workers from deterministic health effects following major accidents, different radiological criteria may be applied in emergencies.

At KNPS samples are collected from Indicator sites, that are locations considered close enough to be affected by Koeberg's Operation, and are within a 16 km radius from the plant. Samples are also collected from control sites; these are locations

considered to be far enough from Koeberg to not be affected by its operations. Activity found at these locations is considered to be representative of general activity in the environment.

The effluent from KNPS is monitored on a regular basis for gross alpha and beta determinations. The growing need to quantify alpha emitting radionuclides in the environment and in nuclear fuel processing has resulted in dramatic increases in gross alpha / gross beta measurements. Gross alpha / gross beta counting has become the most widely used method of monitoring for the presence of radioactivity.

Much of the interest is due to the need to address safety, regulatory compliance, and disposal issues for both alpha and beta radionuclides.

Gamma spectrometry cannot be performed for the detection of natural and artificial nuclides that lack the necessary attending gamma energies, such as  $^3\text{H}$ ,  $^{14}\text{C}$ ,  $^{90}\text{Sr}$ ,  $^{238}\text{Pu}$ ,  $^{239}\text{Pu}$ ,  $^{240}\text{Pu}$  and  $^{241}\text{Pu}$ . Radionuclides  $^3\text{H}$ ,  $^{14}\text{C}$ , and  $^{90}\text{Sr}$  are pure beta emitters, without the attending gamma rays. Even though some of the Pu isotopes emit gamma rays, their emission lines offer no secure identification due to other energy lines caused by NORM (naturally occurring radioactive material). Thus, these radionuclides can be summarised as HTM (hard to measure) nuclides. HTM can still be determined by other spectrometric methods, such as liquid scintillation counting (LSC) and alpha spectrometry, although sample preparation procedures are very complex for these methods. A radiochemical separation procedure is needed prior to analysis.

For the screening of samples on gamma spectrometry, an interesting nuclide of concern is the occurrence or absence of  $^{241}\text{Am}$ .  $^{241}\text{Am}$  is the only transuranic element that is readily detectable by gamma spectrometry, due to its emission line at 59.9 keV. It is a progeny of  $^{241}\text{Pu}$ , an activation product that is created among the other Pu isotopes, by the neutron capture of  $^{238}\text{U}$ , and subsequent beta decay.  $^{241}\text{Pu}$  decays to  $^{241}\text{Am}$ , and is a beta emitter, whereas all other Pu isotopes are alpha emitters. Thus, the presence of  $^{241}\text{Am}$ , points to the presence of  $^{241}\text{Pu}$ . [2]

Gamma emitters  $^{60}\text{Co}$ ,  $^{65}\text{Zn}$ ,  $^{152}\text{Eu}$ , and  $^{137}\text{Cs}$  are all formed by neutron activation, but  $^{137}\text{Cs}$  is a clear sign of fission. When  $^{137}\text{Cs}$  is detected, samples are also analysed for  $^{90}\text{Sr}$ . [3]



Conversion plants are operation commercially in the USA, Canada, France, Russia and China.

### World Primary Conversion capacity

Company	Nameplate capacity (tonnes U/yr as UF <sub>6</sub> )	Approx capacity utilisation 2015	Capacity utilisation 2015, tU/yr
Cameco, Port Hope, Ont, Canada	12,500	70%	8750
Springfields Fuels, UK	(closed August 2014)	0%	0
TVEL at Siberian Chemical Combine, Seversk, Russia	12,500	100% assumed	12,500
Comurhex (Areva), Malvesi (UF <sub>4</sub> ) & Tricastin (UF <sub>6</sub> ), France	15,000	70%	10,500
Converdyn, Metropolis, USA	15,000	70%	10,500
CNNC, Lanzhou, China	5000	unknown	4000
IPEN, Brazil	100	70%	70
<b>World Total</b>	<b>60,100</b>		<b>46,320</b>

World Nuclear Association *Nuclear Fuel Report 2013 & 2015*; World Nuclear Association information paper on [China's Nuclear Fuel Cycle](#).

The main process involves dissolving the oxide concentrate in nitric acid to produce uranyl nitrate, purifying this, evaporation of the purified uranium stream and thermal decomposition to UO<sub>3</sub> powder. This 'wet process' is used by Cameco in Canada, by Areva in France and also at Lanzhou in China and Seversk in Russia.

The uranium trioxide is reduced in a kiln by hydrogen to uranium dioxide. This is then reacted in another kiln with hydrogen fluoride (HF) to form uranium tetrafluoride (UF<sub>4</sub>). The tetrafluoride is then fed into a fluidised bed reactor with gaseous fluorine to produce UF<sub>6</sub>. This three-step process minimises fluorine demand.

The 'dry process' used in the USA proceeds by using a dry fluoride volatility process at high temperature straight to UF<sub>6</sub>, which is then refined.

### Chemistry of Conversion

In the dry process, uranium oxide concentrates are first calcined (heated strongly) to drive off some impurities, then agglomerated and crushed.

For the wet process, the concentrate is dissolved in nitric acid. The resulting clean solution of uranyl nitrate UO<sub>2</sub>(NO)<sub>2</sub>·2.6H<sub>2</sub>O is fed into a counter current solvent extraction process, using tributyl phosphate dissolved in kerosene or dodecane. The uranium is collected by the organic extractant, from which it can be washed out by

dilute nitric acid solution and then concentrated by evaporation. The solution is then calcined in a fluidised bed reactor to produce  $\text{UO}_3$  (or  $\text{UO}_2$  if heated sufficiently).

Alternatively, the uranyl nitrate may be concentrated and have ammonia injected to produce ammonium diuranate, which is then calcined to produce pure  $\text{UO}_3$ .

Crushed  $\text{U}_3\text{O}_8$  from the dry process and purified uranium oxide  $\text{UO}_3$  from the wet process are then reduced in a kiln by hydrogen to  $\text{UO}_2$ :

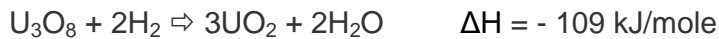

Or



This reduced oxide is then reacted in another kiln with gaseous hydrogen fluoride (HF) to form uranium tetrafluoride ( $\text{UF}_4$ ):



The tetrafluoride is then fed into a fluidised bed reactor or flame tower with gaseous fluorine to produce uranium hexafluoride,  $\text{UF}_6$ . Hexafluoride ('hex') is condensed and stored.

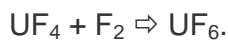

### Depleted uranium and Deconversion

Depleted uranium is stored long-term as  $\text{UF}_6$  or after deconversion, as  $\text{U}_3\text{O}_8$ , allowing HF to be recycled. It may also be deconverted to  $\text{UF}_4$ , which is more stable, with much higher temperature of volatilisation.

The main deconversion plant is the 20 000 t/yr one run by Areva NC Tricastin, France, and over 300 000 tonnes have been processed at the plant. Essentially a dry process is used, with no liquid effluent.

The  $\text{UF}_6$  is first vapourised in autoclaves with steam, then uranyl fluoride ( $\text{UO}_2\text{F}_2$ ) is reacted with hydrogen at 700 C to yield an HF product for sale to converters and  $\text{U}_3\text{O}_8$  powder which is packed into 10-tonne containers for storage.

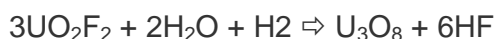

## **1.2 Environmental pollution**

### **1.2.1 Nuclear weapon tests**

When nuclear weapons were tested above ground, they propelled a variety of radionuclides into the upper atmosphere. The radionuclides transferred slowly to the lower atmosphere and then to the earth's surface. Around 500 atmospheric explosions were conducted before the limited test ban treaty was enacted in 1963, with a few more until 1980. The concentrations of radionuclides in air, rain and human diet are now much lower than the peak values in the early 1960's. Globally, the most important radionuclides from testing in terms of human exposures are  $^{14}\text{C}$ ,  $^{90}\text{Sr}$ , and  $^{137}\text{Cs}$ . Minute quantities of these are ingested with food and drink.

### **1.2.2 Chernobyl accident**

An explosion in a nuclear reactor at the Chernobyl nuclear power plant on 26<sup>th</sup> April 1986 caused the release of substantial quantities of radionuclides. Airborne material was dispersed throughout Europe and beyond. Local weather conditions largely determined where the radionuclides were to fall. The accident had a catastrophic effect locally and high radiation exposures of emergency workers led to the deaths of 31 people, including 28 firemen. The firemen received large external doses from deposited radionuclides, between 3 and 16 Sv, and contamination on their skin led to severe erythema, mostly due to beta emitters.

### **1.2.3 Radioactive discharges**

Radionuclides of artificial origin are discharged to the environment by the nuclear power industry, military establishments, research organisations, hospitals and general industry. Discharges of any significance are subject to statutory control, and are monitored and authorised. The nuclear power industry discharges the most activity. At each stage of the nuclear fuel cycle, a variety of nuclides are released in the form of liquids, gases, or solid particles. <sup>[4]</sup>

### **1.2.4 Waste management at nuclear facilities**

The controlled release of radionuclides to the atmospheric and aquatic environments is a legitimate waste management practice in the nuclear industry and its related facilities.

Typically, controlled discharges of gaseous and particulate material containing radionuclides are made through stacks, although for small facilities they may be made through discharge vents or working hoods. Controlled liquid discharges are typically made via pipelines into rivers, lakes or the sea, but they may also be made via the normal sewer systems from small establishments. An important and essential element in the control of the discharges is regular monitoring — both at the source of

the discharge and in the receiving environment — to ensure the protection of the public and the environment.

The uncontrolled release of radionuclides to the atmospheric, aquatic and terrestrial environments may occur as a result of a nuclear or radiological accident. Monitoring of the accidental release at its source, and especially the direct monitoring of the environmental contamination with radionuclides, is necessary for the assessment and execution of actions for public protection and longer term countermeasures as well as of emergency occupational radiation protection. In areas historically contaminated with long lived radionuclides, monitoring is essential for protection of the public and as a basis for restoration activities. <sup>[5]</sup>

The general objectives of any monitoring programme for the protection of the public and the environment are:

- (a) To verify compliance with authorized discharge limits and any other regulatory requirements concerning the impact on the public and the environment due to the normal operation of a practice or a source within a practice.
- (b) To provide information and data for dose assessment purposes and to assess the exposure or potential exposure of critical groups and populations due to the presence of radioactive materials or radiation fields in the environment from the normal operation of a practice or a source within a practice and from accidents or past activities.
- (c) To check the conditions of operation and the adequacy of controls on discharges from the source and to provide a warning of unusual or unforeseen conditions and, where appropriate, to trigger a special environmental monitoring programme. One important purpose of monitoring is to provide data that permit the analysis and evaluation of human radiation exposure. For this purpose, programmes for monitoring radionuclides in the environment should focus on pathways of human exposure. An exposure pathway defines routes from a source of radionuclides and/or radiation to a target individual or a population through media in the environment. There are two main categories of exposure pathway: external exposure pathways (the source of exposure remains outside the body) and internal exposure pathways (the source of exposure is incorporated into the body).

The main external exposure pathways are:

- (a) *Source of radiation to human*: direct exposure from a source of ionizing;
- (b) *Source of radionuclides to atmosphere or water body*: exposure due to the plume of radionuclides in the atmosphere ('cloud shine') or water;
- (c) *Source of radionuclides to atmosphere or water body to human skin*: contact exposure from radionuclides on the skin;
- (d) *Source of radionuclides to atmosphere or water body to soil or sediment or building surface or vegetation to human*: exposure from the deposited on the

ground or on sediments (on the shores of rivers, lakes or the sea) or building surfaces (walls, roofs and floors) or vegetation (trees, bushes and grass).<sup>[6-7]</sup>

### **Effluent systems at Koeberg Power station**

At KNPS, or any other nuclear power station, not only conventional waste, but also nuclear or radioactive waste is produced, which cannot just be discharged into the environment. All radioactive waste is treated and/or monitored before any is released or removed from site.

In South Africa, release limits for radioactive nuclides are approximately 100 times more stringent than that of the rest of the world. Conventional waste also has to be treated before discharge to the environment, even if the treatment consists only of neutralisation. Some conventional effluents have the potential to become radioactive and as such are monitored continuously during their release to prevent unquantified and unauthorised releases.

### **Objective of Study**

This aim of this work is to investigate the application Sr-Spec resin in the analysis of <sup>90</sup>Sr in both effluent samples as well as environmental samples at Koeberg Power Station. This work will look at the radiochemistry instrumentation at KNPS that can be used in the analysis. The instruments of concern are the Liquid Scintillation Counter, and an Alpha/Beta gas proportional counter. This work will present the calibration of both these instruments. Important considerations for this work focussed on the ease of method, time-saving for easy decision-making as well as personnel safety.

### **Research Approach**

This work will present a comparison between the traditional fuming nitric acid method as is currently used at KNPS for effluent samples, and using the Sr-Spec resin for effluent samples. This work will also look at methods to use the Sr-Spec resin for <sup>90</sup>Sr analysis on environmental samples. There are two radiometric instruments that can be used for analysis of <sup>90</sup>Sr in effluent as well as environmental samples. These are the Liquid scintillation Counter as well as the Alpha/Beta Gas Proportional Counter. These instruments will be calibrated for this analysis, and will be used for this analysis at KNPS. The literature review presents the different methods that can be used for <sup>90</sup>Sr analysis, ie. Traditional Fuming Nitric Method, Ion- Exchange Chromatography and Solvent Extraction. Other extractions are those commercially available from Eichrom Ind., including the Sr-Spec resin.

## Problem Statement

Currently at the KNPS, the traditional fuming nitric acid is used to analyse for Sr-90 in effluent samples. The fuming nitric acid method is a reliable method, however the considerations for exploring the Sr-Spec method is that it is time-saving, in that it eliminates all the precipitation steps as is found in the traditional method, it is safer to use, since no fuming nitric acid is used, different concentrations of HNO<sub>3</sub> is used, with 8 M being the highest concentration. The Sr-Spec method also gives a better MDA, since a higher volume of sample is used.

All environmental samples requiring Sr-90 analysis is sent to Necsa for analysis. This service has proven to be very costly, and if the analysis can be done at KNPS, it will be cost - saving.

### 1.3 Strontium and the importance of its analysis

Strontium, a silvery white alkaline earth metal exists in several stable and unstable isotopes. Strontium is found naturally as a non-radioactive element, and has 16 known isotopes. Naturally occurring strontium is found as four stable isotopes, <sup>84</sup>Sr, <sup>86</sup>Sr, <sup>87</sup>Sr and <sup>88</sup>Sr. <sup>90</sup>Sr like many other radionuclides was discovered in the 1940's in nuclear experiments connected to the development of the atomic bomb.

Radiostrontium (<sup>89</sup>Sr and <sup>90</sup>Sr), has been released to the environment by global fall-out following atmospheric nuclear explosions by nuclear waste discharges and fall-out from the Chernobyl accident. As <sup>89</sup>Sr has a short half-life, it quickly decays to undetectable levels, while <sup>90</sup>Sr is radiobiologically more important because of its longer half-life and accumulation in bone tissue.

<sup>90</sup>Sr is a by-product of the fission of uranium and plutonium in nuclear reactors and in nuclear weapons. <sup>90</sup>Sr is found in waste from nuclear reactors and can also contaminate reactor parts and fluids. Large amounts of <sup>90</sup>Sr were produced during atmospheric nuclear weapon tests and dispersed worldwide during the 1950's and 1960's. [8-11]

<sup>90</sup>Sr is considered one of the more hazardous components of radioactive fall-out. Owing to its chemical similarities to calcium <sup>90</sup>Sr is efficiently incorporated into bone and tissue. Characterised by a long physical and biological half-life (28 yrs and 7 yrs respectively), <sup>90</sup>Sr may cause damage to bone marrow because of its high energy beta particle (E=546 keV). The radionuclide is a beta emitter, radiating the tissue in which it is embedded. <sup>90</sup>Sr forms many chemical compounds, including halides, oxides and sulphides, and moves easily through the environment. Nuclear power plant accidents such as a reactor meltdown, with or without failed containment, fallout from nuclear detonations or radiological attacks, leads to radioactive strontium becoming incorporated into the calcium pool.

If released into the environment, trace amounts of <sup>90</sup>Sr may be inhaled as a contaminant in dust. Swallowing <sup>90</sup>Sr with food, milk or water is the primary pathway of intake.

$^{90}\text{Sr}$  is one of the most important anthropogenic radionuclides from a long-term radiological point of view. It decays by emitting beta radiation with a maximum energy of 546 keV into  $^{90}\text{Y}$ , which decays with a half-life of 64.1 hr into stable  $^{90}\text{Zr}$ , emitting beta radiation with a maximum energy of 2.28 MeV. [12]

Fig.2. Sr-90 Fission Decay Chain

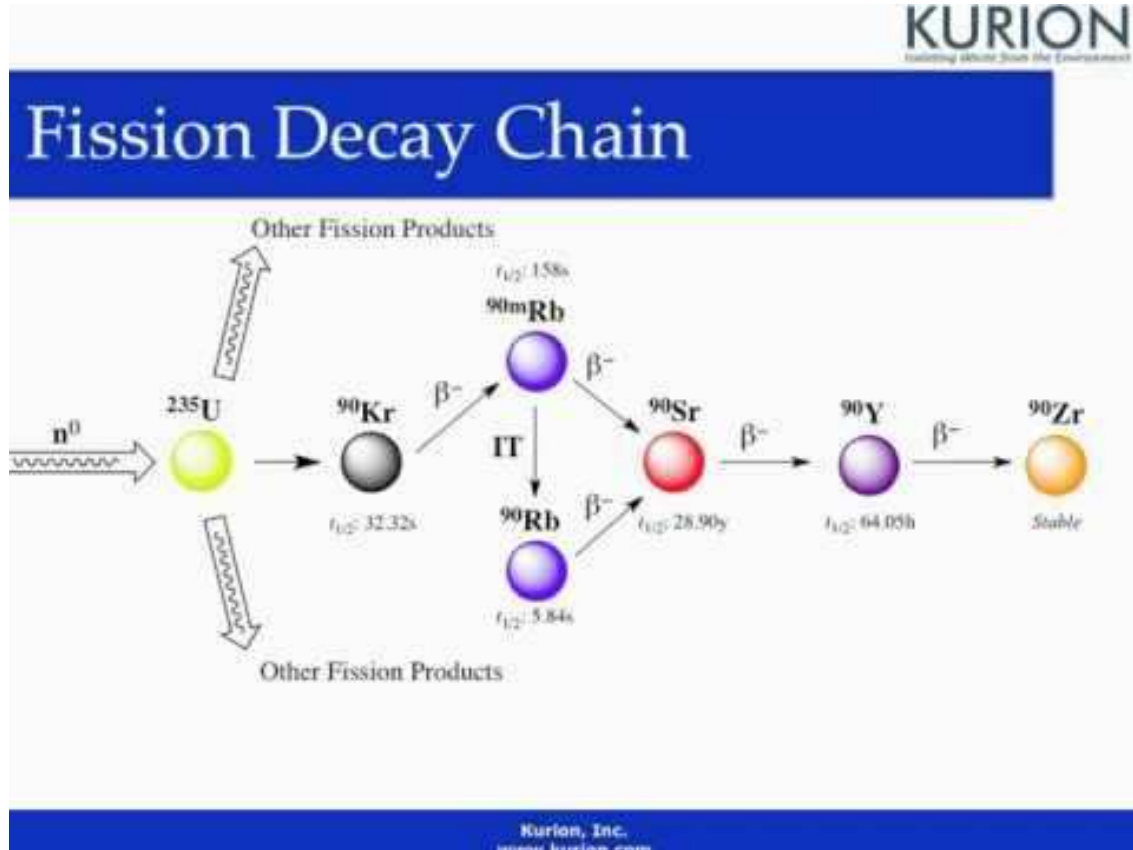

$^{90}\text{Sr}$  is a radioactive isotope of strontium produced by nuclear fission, with a half-life of 28.8 years.  $^{90}\text{Sr}$  has applications in medicine and industry and is an isotope of concern in fallout from nuclear weapons and nuclear accidents.

Naturally occurring strontium is non-radioactive and non-toxic at levels normally found in the environment, but  $^{90}\text{Sr}$  is a radiation hazard.  $^{90}\text{Sr}$  undergoes  $\beta^-$  decay with a half-life of 28.79 years and a decay energy of 0.0546 MeV, distributed to an electron, an anti-neutrino, and the yttrium isotope  $^{90}\text{Y}$ , which in turn undergoes  $\beta^-$  decay with half-life of 64 hours and decay energy of 2.2 MeV distributed to an electron, an anti-neutrino, and  $^{90}\text{Zr}$ , which is stable.  $^{90}\text{Sr}/^{90}\text{Y}$  is almost a pure beta particle source, the gamma photon emission from the decay of  $^{90}\text{Y}$  is so infrequent that it can normally be ignored.  $^{90}\text{Sr}$  is a “bone seeker” that exhibits biochemical behaviour similar to calcium. After entering the organism, most often by ingestion with contaminated food or water, about 70 – 80% of the dose gets excreted. Virtually all remaining  $^{90}\text{Sr}$  is deposited in bones and bone marrow, with the remaining 1% remaining in blood and tissues. Its presence in bones can cause bone cancer, cancer of nearby tissue, and leukemia. The biological half-life of  $^{90}\text{Sr}$  in humans has variously been reported as from 14-600 days, 1000 days, 18 years, 30 years and at an upper limit, 49 years. The wide ranging published biological half-life figures are due to  $^{90}\text{Sr}$ ’s complex metabolism within the body. Averaging all excretion paths, the

overall biological half-life is estimated to be about 18 years. The elimination of  $^{90}\text{Sr}$  is strongly affected by age and sex, due to differences in bone metabolism.

$^{90}\text{Sr}$  is not quite as likely as  $^{137}\text{Cs}$  to be released as a part of a nuclear reactor accident because it is much less volatile, but is probably the most dangerous component the radioactive fallout from a nuclear reactor.

Together with the caesium isotopes,  $^{134}\text{Cs}$ ,  $^{137}\text{Cs}$  and the iodine isotope  $^{131}\text{I}$ , it was among the most important isotopes regarding health impacts after the Chernobyl disaster.

### Other Fission Products as environmental contaminants

#### $^{137}\text{Cs}$

$^{137}\text{Cs}$  decay has a half-life of 30.07 years and decays by both  $\beta$  decay and  $\gamma$ -emission from an intermediate state. Both the electron and gamma emissions are highly ionising radiation. The gamma radiation is very penetrating, and the beta radiation, is very dangerous when ingested because it deposits all that energy in a very short distance in tissue.

$^{137}\text{Cs}$ 's danger as an environmental hazard, damaging when ingested, is made worse by its mimicking of potassium's chemical properties.

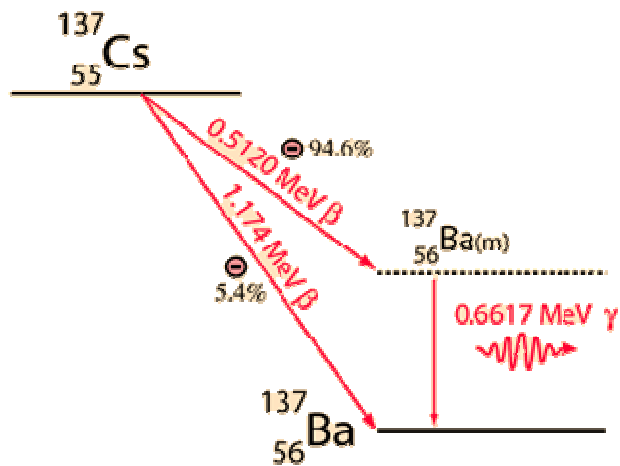

#### $^{131}\text{I}$

$^{131}\text{I}$  is a major concern in any kind of radiation release from a nuclear accident because it is volatile and because it is highly radioactive, having an 8 day half-life. It is of further concern in the human body because iodine is quickly swept up by the thyroid, so that the total intake of iodine becomes concentrated there. The thyroid has a maximum uptake of iodine. Some protection against iodine releases can be afforded by taking iodide tablets to load up the thyroid capacity so that radioactive iodine would be excreted.

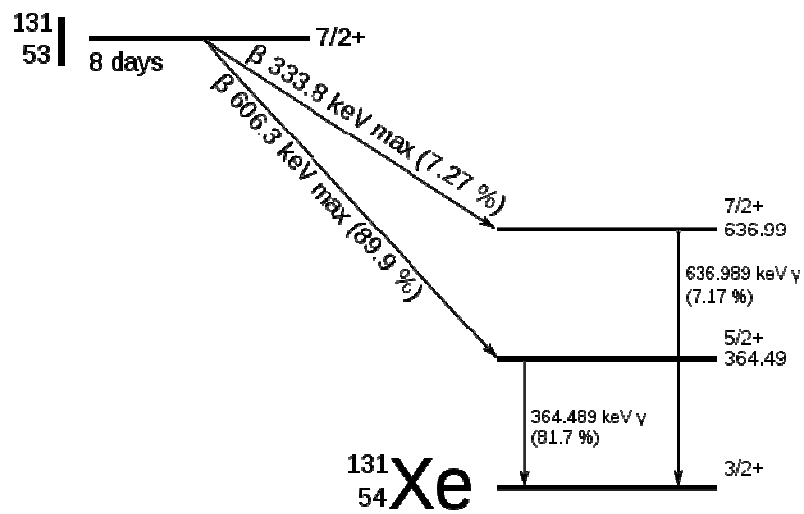

**Fig.3. Radioactive Decay**

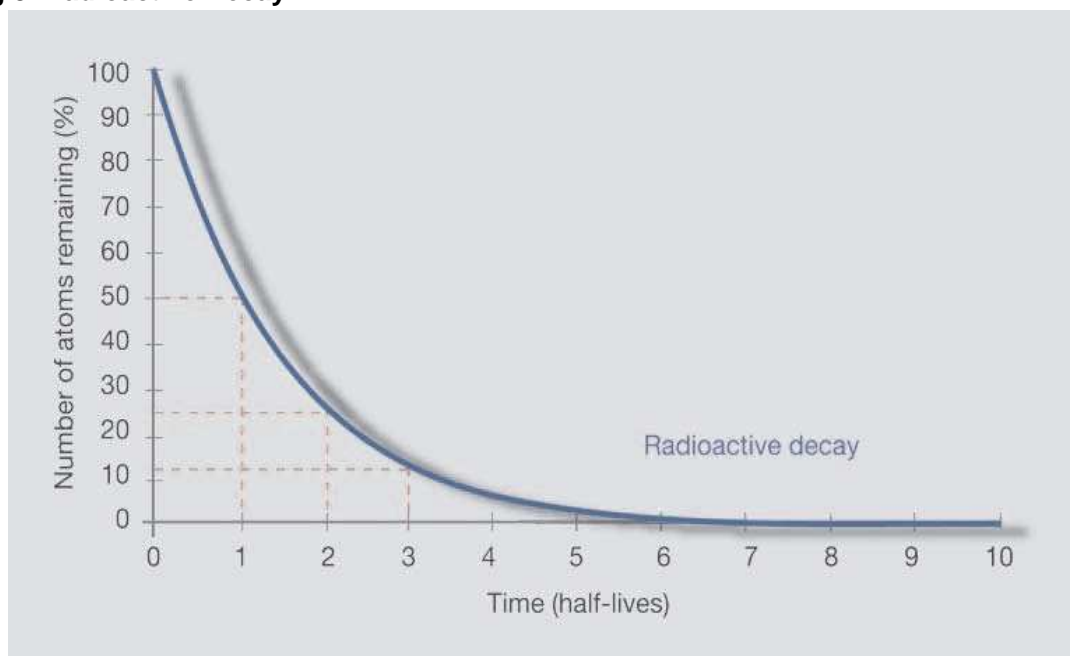

The chemical analogy of strontium and calcium, leading to the long-term storage of  $^{90}\text{Sr}$  in bones, combined with the high-energy beta radiation of  $^{90}\text{Y}$  is responsible for the high radiological impact of  $^{90}\text{Sr}$ . For this reason,  $^{90}\text{Sr}$  is monitored regularly in many types of environmental samples related to the human food chain.

Rapid methods for radiostrontium analysis are important in emergency cases, when many samples have to be analysed in order to enable the authorities to make rapid decisions on the control of food consumption or implement other radiation protection measures based on the contamination level of the environment. The analysis time is an important economic factor, as rapid identification of contamination with radioactive material helps decision makers introduce protective measures.

The  $^{90}\text{Sr}$  activity of a sample can be determined either by analysing  $^{90}\text{Sr}$  itself or its daughter nuclide,  $^{90}\text{Y}$ . Since both nuclides are pure beta emitters, both types of analysis require radiochemical processing of the sample.

Three principle strategies can be applied:

The first method involves the purification of  $^{90}\text{Sr}$ , e.g. by the traditional fuming nitric acid method.

After the purification of  $^{90}\text{Sr}$ ,  $^{90}\text{Y}$  is isolated and measured after waiting for 2 or more weeks to allow  $^{90}\text{Y}$  to reach equilibrium with  $^{90}\text{Sr}$ .

The second strategy involves the purification and direct determination of  $^{90}\text{Sr}$ . This method became more common due to the increasing availability of liquid scintillation (LSC) counters in radio-analytical laboratories and the commercial availability of Sr-Spec resin (Eichrom Ind.) for extraction chromatography.

A third method is based on the direct isolation of  $^{90}\text{Y}$  instead of  $^{90}\text{Sr}$ . Relatively simple and rapid radioanalytical methods are available for its analysis when only  $^{90}\text{Sr}$  is present in a sample. These methods are based on the selective separation and successive counting of  $^{90}\text{Y}$ . Far more complicated and time consuming procedures are required when total radio-strontium has to be measured.

Such a need may occur soon after the accidental release of fission products in the environment, when the contribution of  $^{89}\text{Sr}$  (half-life = 52 days) to the total radio-strontium activity is still significant.

All procedures for the total analysis of radiostrontium are complicated and slow since they require the separation and purification of strontium from various inactive and radioactive elements present in complex sample matrices by chemical procedures exhibiting only limited selectivity. Exemplary is the standard method of analysis of radiostrontium, based on the precipitation of strontium with fuming  $\text{HNO}_3$ .

This method, which consists of nine different precipitation steps, requires between 20 and 30 days. Hence the search for simpler and more rapid radioanalytical methods, which should take advantage of more selective separation agents, became important.

The analysis of radio-strontium is further complicated because  $^{89}\text{Sr}$ ,  $^{90}\text{Sr}$  and its daughter  $^{90}\text{Y}$  are pure beta emitters, and prior to measurements, they must be separated from the sample. Some methods using ion-exchange resins have been attempted for rapid determination of radioactive strontium.

A simple and rapid method has been developed for the separation and successive determination of total radiostrontium.

The method consists of three basic steps:

- Oxalate precipitation to remove bulk potassium,
- Chromatographic separation of strontium from most inactive and radioactive interferences utilizing a crown ether (Sr-Resin, Eichrom Industries, II. USA),
- Oxalate precipitation of strontium to evaluate the chemical yield. [14]

### 1.3.1 The search for selective separation agents for strontium

The original discovery of crown ether was made in 1960 by Charles Pedersen, who was a researcher at DuPont. The synthesis of crown ethers having the ability to form strong complexes with alkali and alkaline earths was first reported by Pedersen in 1967. Since then considerable efforts have been made by chemists to utilize these compounds for analytical chemistry applications. The attractiveness of crown ethers lies in their property to form very selective complexes with many metal ions by properly choosing the cavity size and the nature of the substituents present in the crown ring. In 1986, McDowell *et al.* demonstrated by solvent extraction studies that the cavity size and the flexible structure of dicyclohexano-18-crown-6 and its derivatives provide a very selective complexing environment for Sr ions. <sup>[15]</sup>

On these premises several attempts have been made at developing radioanalytical methods based on the use of this crown ether as a selective solvent extraction reagent of radio-strontium.

However, all these methods are characterized by one or more of the following limitations: high pH's are required for the Sr separation, losses of crown ether occur due to its partial water solubilisation, the selectivity is limited since the crown ether is used in a solvent extraction procedure. To be practically exploited for the analysis of Sr in environmental samples, a crown ether must then be additionally characterized by high solubility in a non-water miscible environment, be practically insoluble in water, its complexing power must be high in strongly acidic media (to avoid troublesome neutralization procedures) and easily reversible, possibly by only increasing the pH of the water solution in which Sr has to be recovered after separation from other cations.

Sr-Spec could be successfully applied also to environmental analysis of samples containing radiostrontium. Some difficulties are bound to be encountered in obtaining very clean separations from K, an abundant constituent of all soils. The selectivity data for Sr over Ca and K (two major components of all types of soils) have been obtained by Horwitz *et al.* <sup>[16]</sup> using relatively low concentrations of these two elements which were not representative of the conditions encountered in practical soil analysis. Since both K and Ca also show some degree of affinity for the crown ether, it has to be expected that they will tend to replace Sr when their concentration exceeds that of radiostrontium by several orders of magnitude. Such a situation occurs in soil samples. In terms of chemical equilibria such a situation can be described by stating that at high concentrations of K and Ca the equilibrium,

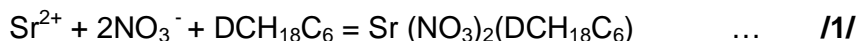

Very much displaced to the right in absence of K and Ca, it will be partially reversed due to presence of the other two equilibria

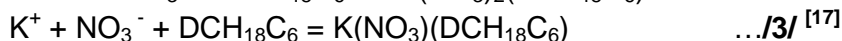
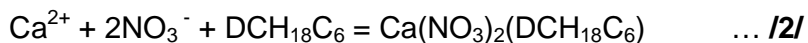

### 1.3.2 Typical Crown Ether

Typical crown ethers are macrocyclic compounds in which pair of carbon atoms and an oxygen atom repeat in regular order. The name likens the large ring to a crown and the oxygens to jewels. Depending on the size of the ring and the number of oxygen atoms, they are called 12-crown-4, 15-crown-5, and 18-crown-6.

Fig. 4. Crown Ethers

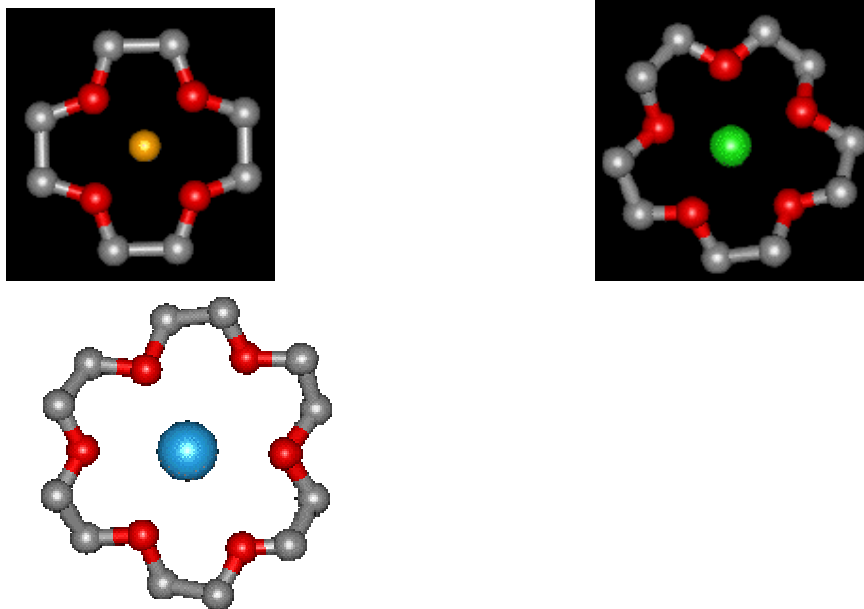

The crown ether ring can capture a positively charged ion like a metal ion and an ammonium ion (the sphere shown inside the ring is the positively charged ion). The negatively charged electrons of the oxygen atoms pointing inward are used to attract and catch the ion. Larger ions fit in larger crown ethers, and smaller ions fit in smaller crown ethers. The ionic radius increases in the order of lithium, sodium, and potassium, and these metal ions are known to be most compatible with twelve-, fifteen-, and eighteen-membered rings, respectively.

It's also known that two crown ether molecules can sandwich an ion. In these cases, an ion larger than the natural fit can be captured. A crown ether with an interesting "switch" property has been synthesized. The molecule shown in Figure 5 is composed of two crown ethers linked by the N=N bond (the central portion). The N=N bond normally has the zigzag shape as shown in the left-hand side picture, but irradiating the molecule with light changes it to the shape shown in the right-hand side picture, causing the crowns to come close to each other.

The molecule can now sandwich an ion, so it's capable of capturing a larger ion than the original state. This molecule is the light-switching crown ether which has the ability to change its ion-selectivity by responding to light.

**Fig 5. Light-switching crown ether**

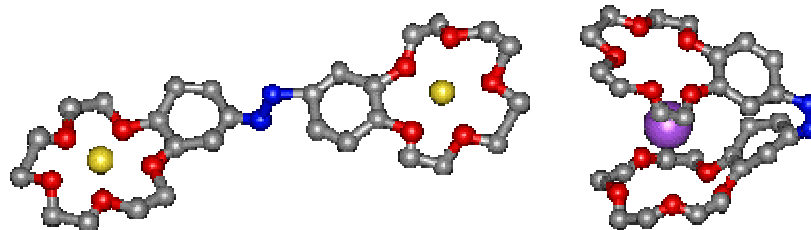

## CHAPTER 2 LITERATURE REVIEW

### 2.1 Traditional fuming nitric acid method:

This classic way of analysing for Sr-90 makes use of the low solubility of  $\text{Sr}(\text{NO}_3)_2$  in fuming nitric acid solutions. The procedure is summarised below:

- Nitrate precipitation (Sr separation from Ca)
- Hydroxide precipitation (Sr separation from actinides and yttrium)
- Chromate precipitation (Sr separation from Ba, Ra and Pb)
- Carbonate precipitation or oxalate precipitation. [18-19]
- Low Sr yields are achieved when using the traditional fuming nitric acid procedure for the determination of Sr in seaweed and seawater samples. The use of fuming nitric acid can be avoided using the procedure proposed by Bojanowski. [19a]

### As used at Koeberg Power Station:

Purification of samples:

- Pour 120 mL of sample in a glass beaker and boil down to 10 mL.
- Add 5 mL of Strontium carrier solution.
- Carefully add 15 mL of fuming  $\text{HNO}_3$ .
- Cool in an ice bath for 15 minutes.
- Centrifuge the sample at 3000 rpm for 10 minutes.
- If no residue after centrifuging, add another 3 mL of strontium carrier and 10 mL of fuming  $\text{HNO}_3$ .
- Stir and cool the sample for 15 minutes, and centrifuge again at 3000 rpm for 10 minutes.
- Discard the supernatant liquid.
- Add 10 mL of demineralised water to dissolve the residue.
- Add 12 mL of fuming  $\text{HNO}_3$ , stir gently, and cool for 15 minutes.
- Centrifuge the sample at 3000 rpm for 10 minutes.
- Discard the supernatant liquid.
- Add 10 mL of demineralised water to dissolve the precipitated  $\text{Sr}(\text{NO}_3)_2$ .

#### Preparation of samples:

- Add 1 mL of Yttrium carrier solution and 2 mL 6M Ammonia solution while stirring on a hotplate.
- Remove beaker from hotplate and cool for 15 minutes.
- Centrifuge at 3000 rpm for 10 minutes.
- Discard the precipitate and transfer the purified supernatant to a glass beaker.
- Add 1 drop of methyl red indicator to supernatant liquid and neutralise with 6 M  $\text{HNO}_3$ .
- Add 1 mL 6 M acetic acid and 2 mL 6 M Ammonium Acetate.
- Heat solution to near boiling.
- Remove the beaker from the hotplate and add 2 mL Barium carrier solution and 1 mL 2 M Sodium Chromate.
- Cool solution and transfer from beaker to centrifuge tube.
- Centrifuge at 3000 rpm for 10 minutes.
- Transfer the purified supernatant into a glass beaker and discard the residue.
- Add a drop of 30% Hydrogen Peroxide and 2 mL Ammonia solution (pH 10).
- Heat the solution to boiling until all the  $\text{H}_2\text{O}_2$  is destroyed.
- Remove the beaker from the hotplate and add 6 mL Ammonium Oxalate saturated solution, while stirring.
- Cool the solution to room temperature.
- Filter the Strontium Oxalate through a pre-weighed 0.45  $\mu\text{m}$  Millipore filter.
- Carefully transfer the filter paper onto a planchet.
- Dry planchet for 30 minutes, and cool for 15 minutes.
- Count planchet on a calibrated alpha/beta proportional counter.

## 2.2 Ion exchange chromatography

Ion exchange chromatography is one of the most popular techniques for radiochemical separations of actinides. <sup>[20-23]</sup>

Both cation exchange and anion exchange from HCl and HNO<sub>3</sub> media have been used for the separation and isolation of Pu. Due to the pronounced ability of the higher valence state actinides to form anionic complexes, anion exchange chromatography is the most selective.

Elements forming anionic nitrate complexes and consequently are retained on anion exchangers from strong nitric acid solutions include: Th (IV), Pa (V), Np (IV), Pu (IV), Pd(II), Au(III), Re(VII) and Tc(VII). These elements are easily separated from the elements which do not form anionic nitrate complexes and are not sorbed, such as Al(III), Fe(II), Fe(III), alkali metals, alkaline earth metals, rare earth metals (Pr to Lu), trivalent actinides, Be, Cd, Co, Ni, Cr(III), Ga, Zn, Ti, V(V). U(VI) are only weakly absorbed from strong nitric acid solutions. <sup>[24]</sup> Since Pu(IV) also forms anionic chloride complexes in strong hydrochloric acid, it can be separated from Th(IV), which does not form anionic chloride complexes, by changing the medium to hydrochloric acid. Usually the column is loaded and washed with 8 M HNO<sub>3</sub> before Th is eluted with 10 - 12 M HCl.

Pu is eluted with HCl containing a reducing agent (e.g. HI, NH<sub>4</sub>I, NH<sub>2</sub>OH.HCl). <sup>[25-31]</sup> Since neither Sr nor Y is retained on the anion exchange column, the HNO<sub>3</sub> eluate can be used for the isolation of these elements, thereby facilitating a sequential analysis of several radionuclides from the same sample.

Am(III) and lanthanides are very weakly retained on anion exchange columns from pure nitric acid solutions unless some of the acid is substituted with an alcohol. <sup>[32-33]</sup> Both Am (III) and light lanthanides are retained on an anion exchanger from 1 M HNO<sub>3</sub> - 93% methanol

Since actinides form stronger complexes with soft donor atoms (S and N) than lanthanides, separation between Am (III) and lanthanides is sub sequentially achieved using NH<sub>4</sub>SCN. As Am (III) forms anionic Am (SCN)<sub>4</sub> - complexes with SCN<sup>-</sup> and lanthanides do not, Am remains retained and the lanthanides are eluted when the media is changed to e.g. 0.1 M HCl / 0.5 M NH<sub>4</sub>SCN–80% methanol. Am can then be eluted using hydrochloric or nitric acid–methanol solution with a higher content of water. <sup>[34-36]</sup>

## 2.3 Solvent extraction

Being the principle technique of choice in the reprocessing of spent fuel and treatment of radioactive waste, several reviews and monographs have been published on solvent extraction techniques and reagents.

### 2.3.1 HDEHP (bis (2-ethylhexyl) phosphoric acid)

HDEHP is a cationic extractant capable of extracting trivalent actinides and lanthanides quantitatively from HCl or HNO<sub>3</sub> solutions with pH higher than 2.5. They are not extracted below pH 1.3<sup>[37]</sup>. The simultaneous extraction of Fe (III) and the formation of precipitates at pH 2 - 3 can cause problems<sup>[38-39]</sup>. A combination of lactic acid and diethylenetriamine-pentaacetic acid (DTPA) solution at pH 2.5 - 3.0 can be used to separate trivalent actinides and lanthanides. In the TALSPEAK process the lanthanides are extracted with HDEHP from aqueous solutions of DTPA and lactic acid, and in the reversed TALSPEAK process the actinides are stripped from HDEHP using DTPA and lactic Acid<sup>[40]</sup>. Extraction with HDEHP can be used to separate trivalent actinides and lanthanides from tetravalent actinides either by extracting tetravalent actinides from strong nitric acid solution (e.g. 4 M HNO<sub>3</sub>) or by extracting both trivalent and tetravalent actinides from a solution with pH higher than about 2.5 and then scrubbing the HDEHP for trivalent actinides by washing with a strong nitric acid solution.<sup>[41]</sup> Pu in the organic phase can be separated from other tetravalent actinides by reductively stripping it as Pu (III)<sup>[42]</sup>. As HDEHP also extracts Y (III), this extractant can be used to perform sequential determination of several actinides and <sup>90</sup>Sr in the same sample<sup>[43]</sup>.

### 2.3.2 TBP (tri-n-butylphosphate)

TBP is frequently used to separate tri-, tetra- and hexavalent actinides from each other. While TBP extracts tetra and hexavalent actinides, tri- and pentavalent actinides and fission products are left in the solution. Reducible tetravalent actinides, e.g. Pu(IV) can then be separated from U(VI) by reductive elution from the TBP phase. Uranium can subsequently be eluted with dilute nitric acid. In the PUREX process TBP is used to separate Pu and U from trivalent actinides (Am, Cm) and fission products.

### 2.3.3 TTA (thenoyltrifluoroacetone)

TTA has also been used to separate actinides in different oxidation states. Extraction of all other oxidation states except tetravalent is negligible at pH 1, while tri-, tetra- and hexavalent can be extracted quantitatively at pH about 4 - 5, the extraction of heptavalent actinides being negligible.<sup>[44-45]</sup> TTA extraction has also been used to separate Pu from Fe, Pu and Fe is extracted with 0.5 M TTA from 1 M HNO<sub>3</sub>. When Pu (IV) is stripped with 10 M HNO<sub>3</sub>, Fe (III) stays in the organic phase<sup>[46-47]</sup>.

### 2.3.4 Other extractants

Sekine *et al.* used TNOA (tri-n-octylamine) to extract Pu(IV) from 4 M HNO<sub>3</sub> after treatment of 50 grams of soil. Pu was then reductively stripped with HCl containing NH<sub>4</sub>I. TIOA (tri-isooctylamine) has also been used to separate U, Np and Pu by extracting them with TIOA from 8 M HCl. Pu is eluted with 8 M HCl containing NH<sub>4</sub>I as reducing agent, Np with 4 M HCl – 0.02 M HF and U with 0.1 M HCl. DDCP (dibutyl-N,N-diethylcarbamoylphosphonate) is a good extractant for the extraction of trivalent actinides and lanthanides from concentrated HNO<sub>3</sub>.

## 2.4 Extraction chromatography

Extraction chromatography is a technique that combines the selectivity of solvent extraction with the ease of operation of column chromatography. Extraction chromatography is ideally suited to laboratory scale analysis of a wide range of metal ions present in environmental and bioassay samples. Extraction chromatography is ideally suited to the separation of radionuclides from a wide range of sample types.

There are three major components of an extraction chromatography system:

- The inert support - Usually consists of porous silica or an organic polymer ranging in size from 50 to 150 µm in diameter. Much smaller or larger particles have been studied for special applications.
- The stationary phase - Either single compounds, or mixtures, are used as the stationary phase.
- The mobile phase - Diluents can be used to help solubilise the extractant and to increase the hydrophobicity of the stationary phase. The mobile phase is usually an acidic aqueous solution, such as nitric or hydrochloric acid, and complexing agents can be added to further increase selectivity.

The pioneering work on extraction chromatography was done during the late 1950's and early 1960's and the technique was first proposed by Siekierski in 1959 <sup>[48]</sup>. Since then many different resins have been prepared and evaluated. It is a well-established technique and has been used widely for the separation of inorganic analytes. A comprehensive survey of this technique is given in the treatise by Braun and Ghersini <sup>[49]</sup> and Cortina and Warshawsky <sup>[50]</sup>.

Many well-known extractants, such as bis (2-ethylhexyl) phosphoric acid (HDEHP), tri-butylphosphate(TBP), tri-n-octylphosphine oxide (TOPO), octylphenyl-N,N-diisobutyl carbamoylphosphine oxide (CMPO), thenoyltrifluoroacetone (TTA), tri-n-octylamine(TNOA), tri-n-octylmethylammoniumchloride etc., have been used in extraction chromatographic separations of especially actinides.

The use of extraction chromatography in radionuclide separations found a wider application in the 1990's when a series of new resins became commercially available. Horwitz and co-workers have developed several extraction resins containing well-known extractants. A description of these can be seen in Table 2.1 below.

**Table 2.1. Resins commercially available from Eichrom Industries.**

<b>Resin</b>	<b>Active extractant</b>	<b>Application</b>
<b>Sr-Resin</b>	bis-4,4,(5.)-tert-butyl cyclohexano-18-crown-6	Sr, Pb, Po
<b>TRU-Resin</b>	octylphenyl-N,N-di-isobutyl carbamoylphosphine oxide (CMPO)	Th, U, Pu, Am, Cm
<b>RE-Resin</b>	octylphenyl-N,N-di-isobutyl	Rare earth elements
<b>UTEVA-Resin</b>	diamylamylphosphonate (DAAP)	U, Th, Np, Pu
<b>TEVA-Resin</b>	tri-n-octylmethylammonium chloride	Th, Np, Pu, Tc, Am, Ln
<b>Ni-Resin</b>	dimethylglyoxime (DMG)	Ni
<b>Actinide-Resin</b>	P,P'-di(2-ethylhexyl) methane-diphosphonic acid	Th, U Am, Pu
<b>Pb-Resin</b>	bis-4,4'(5')-tertbutylcyclohexano-18-crown-6	Pb
<b>Ln-Resin</b>	bis(2-ethylhexyl) phosphoric acid (HDEHP)	lanthanides, Ra

Besides the commercial Eichrom products, Testa has for many years (since his article about TNOA impregnated paper for the chromatographic separation of metal ions had been published in 196) <sup>[51]</sup>, used extraction chromatographic separations <sup>[51-60]</sup>. For Pu separations his group used TOPO and TNOA columns. Chromatographic separations of yttrium (for the determination of <sup>90</sup>Sr) and of americium were utilized using HDEHP columns.

**Fig.6. Sr- Spec Resin**

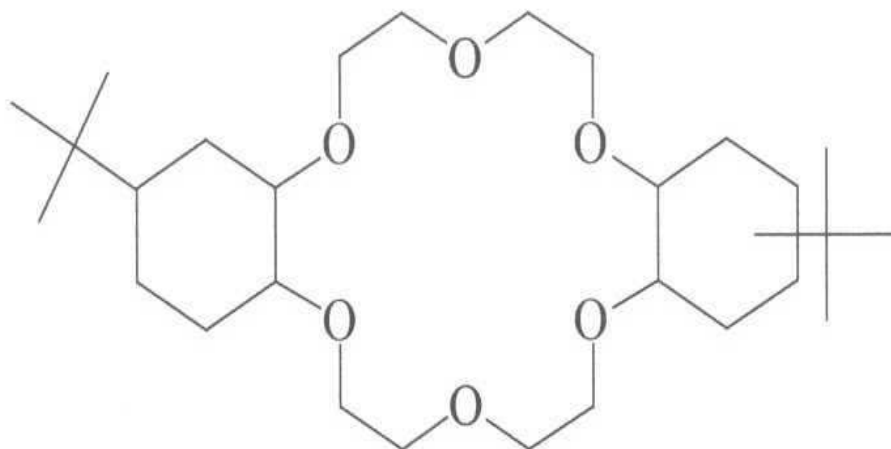

**Diluent: 1-octanol**

1.0 M 4,4'(5')-di-t-butylcyclohexano 18-crown-6 in 1-octanol.

40% (w/w) loaded onto inert chromatographic support.

Bed density of Sr Resin approximately 0.35 g/mL.

Sr max. capacity: 21 mg / 2mL resin bed,

Advised working capacity: max. 8 mg / 2mL resin bed (Opt.: 5 mg)

The extractant in Sr-Resin consists of the crown ether 4,4'(5')-di-t-butylcyclohexano 18-crown-6, abbreviated DTBCH18C6, dissolved in 1-octanol. High nitrate concentrations promote the extraction of strontium, while contact with water reverses the reaction thereby stripping Sr. In this manner Sr can easily be stripped without use of any complexing agents. When extracting Sr from 3 M HNO<sub>3</sub>, less than 0.5% of Sr introduced is eluted with the first 30 FCV.s (free column volume) while about 98% is eluted with the first 2.5 FCV.s when the medium is changed to water. <sup>[61]</sup>

The Sr-Resin also retains small amounts of potassium and since most environmental samples contain large amounts of potassium a good separation of Sr and K is usually achieved if an oxalate precipitation of Sr is done before the separation of Sr and K on the Sr-Resin. If the final Sr or Y source is made by oxalate precipitation, this separation can also be achieved in the source preparation step. Ba is also extracted by the resin.

A good separation of Sr from Ba can be achieved by the sorption of Sr from 8 M HNO<sub>3</sub> and eluting Ba with 8 M HNO<sub>3</sub>.

Tetravalent actinides are extracted very strongly by the resin and Pu(IV) retention is even higher than Sr(II) retention for nitric acid concentrations above about 1 M.

Actinides can also be stripped very easily from the column, without stripping Sr, by washing the column with nitric acid containing oxalic acid.

Large amounts of Ca in the sample also lead to low recoveries of Sr. When using a 2 mL Sr-Resin column Sr recoveries start to drop when Ca amount exceeds about 0.3 gram and almost no Sr is retained when the Ca amount exceeds about 1.3 gram. A drawback is the low Sr capacity of the resin. Sr amounts exceeding about 10 mg lead to a sharp decrease in Sr recovery on a standard 2 mL column (0.75 g resin). Larger columns can be used to avoid this. Columns can be re-used several times (5 - 10) after appropriate washing with H<sub>2</sub>O and HCl.

The procedure is advantageous for samples not containing too high amounts of Sr or Ca. In emergency situations Sr-Resin separation is recommended due to both its simplicity and since this procedure, contrary to TBP-extraction, also allows the determination of Sr-89. Sr-Resin extracts Sr at the same nitric acid concentration as TRU-Resin extracts Pu and Am. Hence, these resins can also be coupled together to achieve a sequential determination of Sr, Pu and Am.

The extraction chromatographic resin were prepared by impregnating Amberchrom CG-71 md (80% within 50 – 100 µm particle size), Amberchrom CG-71 cd (80 % within 80 – 160 µm particle size) or Amberlite XAD (100 – 125 µm particle size) with a 1 M solution of 4,4'(5')-bis-t-butylcyclohexano-18-crown 6 (DtBuCH18C6).

The resultant strontium selective chromatographic resin is commercially available as the Sr-Spec (for Strontium Specific) from Eichrom Industries.

The Sr-Spec resin is ideally suited for the separation of strontium from a wide range of environmental and biological samples, because of its high selectivity for strontium in 2 – 6 M HNO<sub>3</sub> over the major constituents of many samples such as Na, Mg, Ca, Al and Fe. Only K requires special attention.

Two approaches can be taken in reducing the interference from K. First, Sr can be co-precipitated from dissolved samples. Calcium phosphate and carbonate have been found to be effective for this purpose. Alternatively, the column can be loaded from 6 M HNO<sub>3</sub>. The selectivity of Sr over K ( $K_{Sr/K}$ ) from 6 M HNO<sub>3</sub> is 110 compared to 25 from 3 M HNO<sub>3</sub>.

The separation of Sr from Ba and Ra can also be maximised by elution with high HNO<sub>3</sub> concentration or LiNO<sub>3</sub>.

### **<sup>90</sup>Y/ <sup>90</sup>Sr separation**

The separation of <sup>90</sup>Y from its parent <sup>90</sup>Sr is extremely rapid and efficient. The purity of <sup>90</sup>Y with respect to other fission products and commonly occurring impurities such as Na, Ca, Al and Fe is improved because only <sup>90</sup>Sr is retained on the column.

### **Separation of Pb from Environmental Samples**

The Sr-selective resin is also ideally suited for the separation of Pb from a wide range of environmental samples, such as soil and groundwater, and from minerals for geochemical purposes. Lead can be stripped from the resin by a variety of reagents.

### **k' vs HNO<sub>3</sub> Concentration**

The effect of HNO<sub>3</sub> concentration on the selectivity of a novel extraction chromatographic resin consisting of an octanol solution of 4,4'(5')-bis(t-butyl-cyclohexano) 18-crown-6 sorbed on an inert polymeric support for Sr over a number of alkaline earth and other metal cations have been evaluated.

The resin is shown to exhibit excellent selectivity for Sr over nearly all of the test elements. Only lead and tetravalent neptunium, plutonium and polonium show significant affinity for the material.

The strontium – selective chromatographic material was characterised by measuring the capacity factor, k', versus the HNO<sub>3</sub> concentration for a wide range of metal ions. The k' for Sr exceeds that of each alkali metal by a wide margin over the range of acidities covered. The resin also shows excellent k' over sodium. The k' for Sr rises steadily with increasing HNO<sub>3</sub> concentration, while for other elements, it reaches a maximum at around 1 -2 M HNO<sub>3</sub> and then declines. This can be seen in Fig.7.

Fig.7. Acid Dependency for various ions

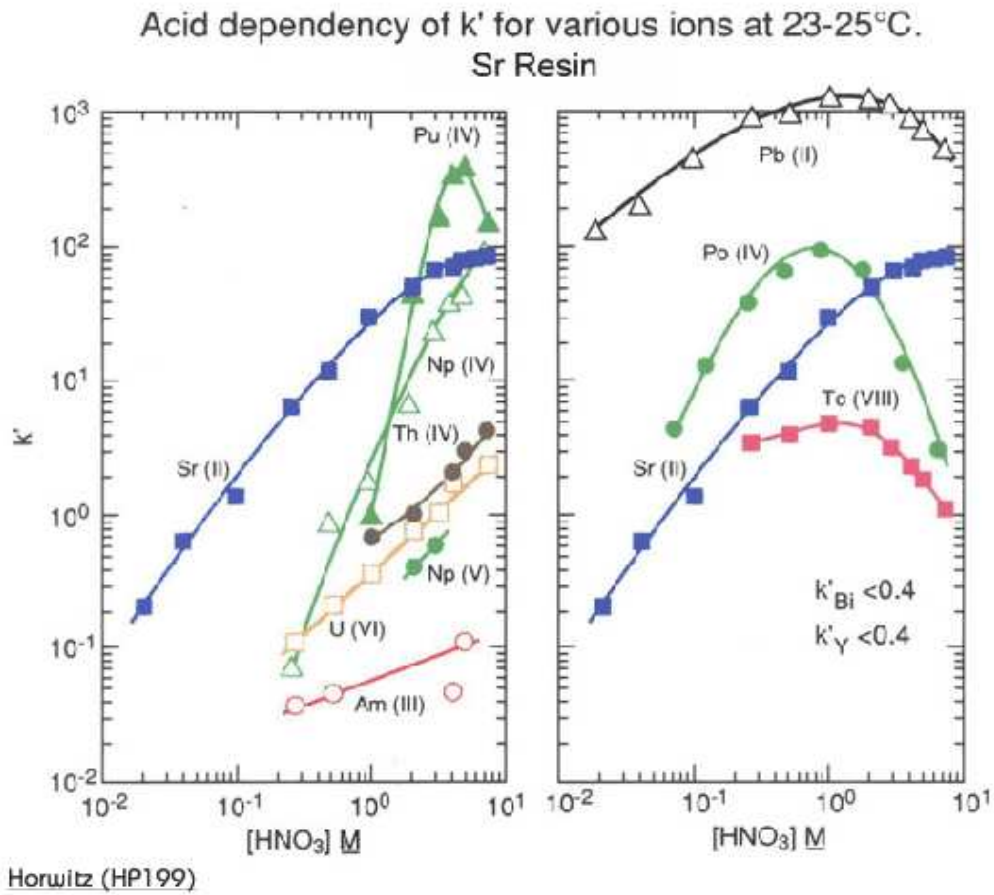

- Good Sr uptake at high  $\text{HNO}_3$ ; easy elution at low  $\text{HNO}_3$  concentrations
- Good selectivity over alkaline and other earth alkaline elements
- Very good selectivity for Pb.

## **2.5 Sample Preparation– Environmental samples**

Organic matter is normally incinerated using dry ashing in muffle furnaces (400-700 °C, depending on the analyte). While some laboratories cover their samples during ashing others do not. Covering the samples avoids cross contamination and loss, but reduces oxygen flow to the sample, thereby yielding poorly ashed samples. As a loss would be more dramatic for small samples, these should preferentially be covered during ashing. Large samples can be ashed uncovered, but care should be taken to not ash these together with samples with very different activity levels. The area exposed to air should be kept as large as possible. Ashing aids such as oxalic acid can also be added to aid the ashing of covered samples. The interior of the muffle furnace should be cleaned periodically to avoid contamination.

Wet ashing on a hotplate or in a microwave oven is occasionally used for ashing purposes, but mostly acid treatment is used for leaching the analyte from the sample.

### **2.5.1 Sample Digestion**

Three digestion techniques may be used for digestion of samples, namely the fusion technique, the microwave oven digestion using a mixture of acids, the digestion on a hot plate using a mixture of acids (leaching or full digestion).

#### **2.6.1.1 Dissolution**

The analytes must be brought into solution before further chemical separations. The ash from pre-treatment of solid samples is therefore subjected to treatment with hot mineral acids.

Leaching of the ash with mineral acids does not necessarily leach out all of the analyte, but the amount not leached is generally low. Uranium, which can be part of the interior of the matrix, and radionuclides bound to or incorporated into refractory oxides are more difficult to leach.

Total dissolution of the matrix using either hydrofluoric acid in combination with mineral acids or by fusion with various fluxes (e.g.  $\text{Na}_2\text{CO}_3$  and alkali borates) is also used. While total dissolution ensures availability of the analyte and a complete exchange between the added tracer and the analyte, it is a laborious procedure complicating the analysis due to the large amount of other elements present in the solution. Normally fusion is performed on small samples.

For emergency monitoring, the fusion technique, if available, is recommended for time reasons. Typical digestion duration using the fusion technique is 1 hour.

Typical digestion duration using the microwave oven is using a mixture of acids is 1 day. Typical digestion duration using the hotplate and a mixture of acids varies from 1 day for leaching to 3 days for a full digestion of the sample. Although the leaching method is quicker than the full digestion, the leaching method could be inadequate in case of radiostrontium embedded in refractory material, leading to incomplete dissolution of the radiostrontium content of the matrix and therefore underestimation of the radiostrontium content. Incomplete digestion may also happen with the use of microwave oven digestion in the presence of refractory materials. Presence of refractory material is dependent on the type of nuclear or radiological emergency.

The use of microwave ovens can simplify the leaching process considerably. As microwaves act on the molecular level they increase the vibration of the molecules and thereby increase the kinetics of the various reactions taking place. Closed microwave systems, requiring the use of pressure vessels, or so-called bombs, are very effective. These vessels hold strong mineral acids or alkalies at temperatures well above normal boiling points, thereby allowing complete digestion or dissolution of samples that would react slowly or incompletely at atmospheric pressure. The drawback is the inability to handle large amounts of material.

In recent years open focused microwave ovens have also been introduced. Since the reactions take place in an open vessel there is no pressure build up. Hence, larger amounts (10 grams) of material can be handled and reagents can be added during the digestion. Since the energy is directed only at the portion of the vessel in the path of the focused microwaves, the neck of the vessel and the refluxer remain cool and ensure refluxing.

#### **2.5.1.2 Digestion using the fusion technique**

- Weigh about 0.5 g of sample to be analysed and distribute evenly in the crucible.
- Add strontium carrier (1 mL of 20 mg/mL in 1M HNO<sub>3</sub>) into the crucible and evaporate gently to dryness on a hotplate.
- Add the following reagents in the given order:
  - 0.2 g NaNO<sub>3</sub> (oxidising agent)
  - 0.2 g Na<sub>2</sub>CO<sub>3</sub> (additive)
  - 2.0 g LiBO<sub>2</sub>
  - 0.1 g KI (non- wetting agent)
- Prepare 100 mL of 1 M HCl.
- Make the fusion using a Fluxer Claisse, an electric muffle furnace or a gas burner.
- Pour the hot melt into the cold solution while stirring vigorously.
- Stir and warm the solution without evaporation until it dissolves completely.
- Cool the solution in a water bath for about 10 minutes.
- Filter solution through a 0.45 µm pore size.

- Add 70 mL of 1M HNO<sub>3</sub> to the solution and heat for 1 hour.
- Wash the filter with 3 mL of 1M HNO<sub>3</sub>, and 1 mL ethanol, then dry for 5 minutes at 80 °C in an oven, followed by 1 hour in a vacuum desiccator.
- Measure the filter for gross alpha and beta activity using a proportional counter. If significant alpha and beta activities remain on the filter, the residue is further processed.

#### **2.5.1.3 Microwave oven digestion using a mixture of acids**

- Transfer 1 g of ashed sample into the Teflon liner of a microwave digestion vessel.
- Add strontium carrier (1 mL of 20 mg/mL in 1M HNO<sub>3</sub>).
- Add 5 mL of 65% HNO<sub>3</sub>, 3 mL 32% HCl, and 10 mL 40% HF.
- Allow for 10 min pre-digestion.
- Place the vessel in its resin sleeve and seal it into the microwave carousel.
- Complete the microwave digestion using an appropriate temperature/ power.
- Upon completion, let solution cool to below 50 °C.
- Add 2 mL of 70% HClO<sub>4</sub>
- Evaporate to near dryness on a hotplate.
- Add 2 mL of 65% HNO<sub>3</sub>.
- Evaporate to near dryness on a hotplate.
- Add 2 mL of 65% HNO<sub>3</sub> and 2 mL de-ionised water.
- Complete the final microwave digestion using an appropriate temperature.
- Upon completion, evaporate to near dryness.
- Add 5 mL of 65% HNO<sub>3</sub> and transfer to a PTFE beaker.
- Add 65 mL of de-ionized water to make a 1 M HNO<sub>3</sub> solution and heat 1 hour.
- Filter solution through a filter paper, 2.5 µm to remove insoluble material.
- Wash the filter with 3 mL of 1M HNO<sub>3</sub> and 1 mL of 80% ethanol, then dry for 5 minutes at 80 °C, followed by 1 hour in a vacuum desiccator.
- Measure filter for gross alpha and beta activity using gas proportional counter.
- If significant alpha/beta activities remain, the residue is further processed.

#### **2.5.1.4 Leaching on a hotplate using a mixture of acids**

- Add 1 g of sample to a glass beaker.
- Add strontium carrier (1 mL of 20 mg/mL in 1M HNO<sub>3</sub>).
- Add 50 mL of aqua regia (mixture of 65 % HNO<sub>3</sub> and 32 % HCl in a volume ratio 1:3)
- Evaporate to moist residue without baking the sample.
- Add 5mL of 65% HNO<sub>3</sub>, and then evaporate to a moist residue, without baking the sample.
- Add 70 mL of 1M HNO<sub>3</sub> and heat for 1 hour.
- Filter the solution through a filter paper, to remove small amounts of insoluble material.

- Wash the filter with 3 mL of 1M HNO<sub>3</sub> and 1 mL of ethanol, then dry for 5 minutes in an oven followed by 1 hour in a desiccator.
- Measure gross alpha and beta activity of the filter using a gas proportional counter. If significant alpha beta activities remain, the residue is further processed.

#### **2.5.1.5 Full digestion on a hot plate using a mixture of acids**

- Add 1 g of sample to a PTFE beaker
- Add strontium carrier (1 mL of 20 mg/mL in 1M HNO<sub>3</sub>).
- Cautiously add 40 mL of 40% HF, and then boil covered for about 2 hours.
- Repeat the step and digest three times with 50 mL of 65% HNO<sub>3</sub>.
- Add 50 mL of 32% HCl and 2-3 g of boric acid to the wet residue and boil for 2 hours.
- Transfer the solution into a glass beaker with a 5 mL of 65% HNO<sub>3</sub> and evaporate to near dryness.
- Add 50 mL of 65% HNO<sub>3</sub> then evaporate to a moist residue without baking the sample.
- If the destruction is not complete (indicated by the evolution of brownish vapour at the end of the evaporation), evaporate again with 10 mL of 65% HNO<sub>3</sub>.
- Add 70 mL of 1M HNO<sub>3</sub> and heat for 1 hour.
- Filter the solution through a filter paper, to remove small amounts of insoluble material.
- Wash the filter with 3 mL of 1M HNO<sub>3</sub> and 1 mL of ethanol, then dry for 5 minutes in an oven followed by 1 hour in a desiccator.
- Measure gross alpha and beta activity of the filter using a gas proportional counter. If significant alpha beta activities remain, the residue is further processed.

#### **2.5.2 Sample Preparation – Liquid Samples**

##### **2.5.2.1 Cation Exchange to Concentrate Sr from water samples**

- Prepare cation exchange columns containing 10 mL of C8-B500-M-H, 100-200 mesh, for each sample analysed.
- Place columns on racks with large reservoirs.
- Add 20 mL of 0.1 M HNO<sub>3</sub> to each column to condition columns.
- Load each sample and allow to drain.
- Add 25 mL 0.1 M HNO<sub>3</sub> to rinse columns.
- Add 50 mL of 8 M HNO<sub>3</sub> to each column to elute the strontium.
- Place on a hotplate and evaporate to dryness.

**Alternatively:** Evaporation to dryness and calcium carbonate precipitation can be used to concentrate strontium.

## CHAPTER 3 INSTRUMENTATION

### **Gamma spectroscopy detectors**

Gamma ray spectrometry is an analytical method that allows the identification and quantification of gamma emitting isotopes in a variety of matrices. In a single measurement and with little sample preparation, gamma ray spectrometry allows you to detect several gamma emitting radionuclides in the sample. The measurement gives a spectrum of lines, the amplitude of which is proportional to the activity of the radionuclide and its position on the horizontal axis gives an idea of its energy.

Applications of gamma ray spectrometry include:

- Monitoring in nuclear facilities
- Health physics
- Nuclear medicine
- Research in materials
- Bioscience
- Environmental science,
- Industrial uses of radioisotopes.

Instrument basics of a typical analog HPGe detector – based gamma spectroscopy system consists of a HPGe detector, high voltage power supply, pre-amplifier, amplifier, analogue to digital converter (ADC), and a multichannel analyser (MCA), as can be seen in Fig.8.

A computer is also required in order to visualise the spectrum and perform basic spectrum analysis using spectrum analysis software.

A detailed analysis of this spectrum is typically used to determine the identity and quantity of gamma emitters present in the source. The gamma spectrum is characteristic of the gamma-emitting nuclides contained in the source, as can be seen in Fig.9 and Fig.10.

**Fig 8. HPGe Detector Operational Characteristics - Cryostat and Dewar**

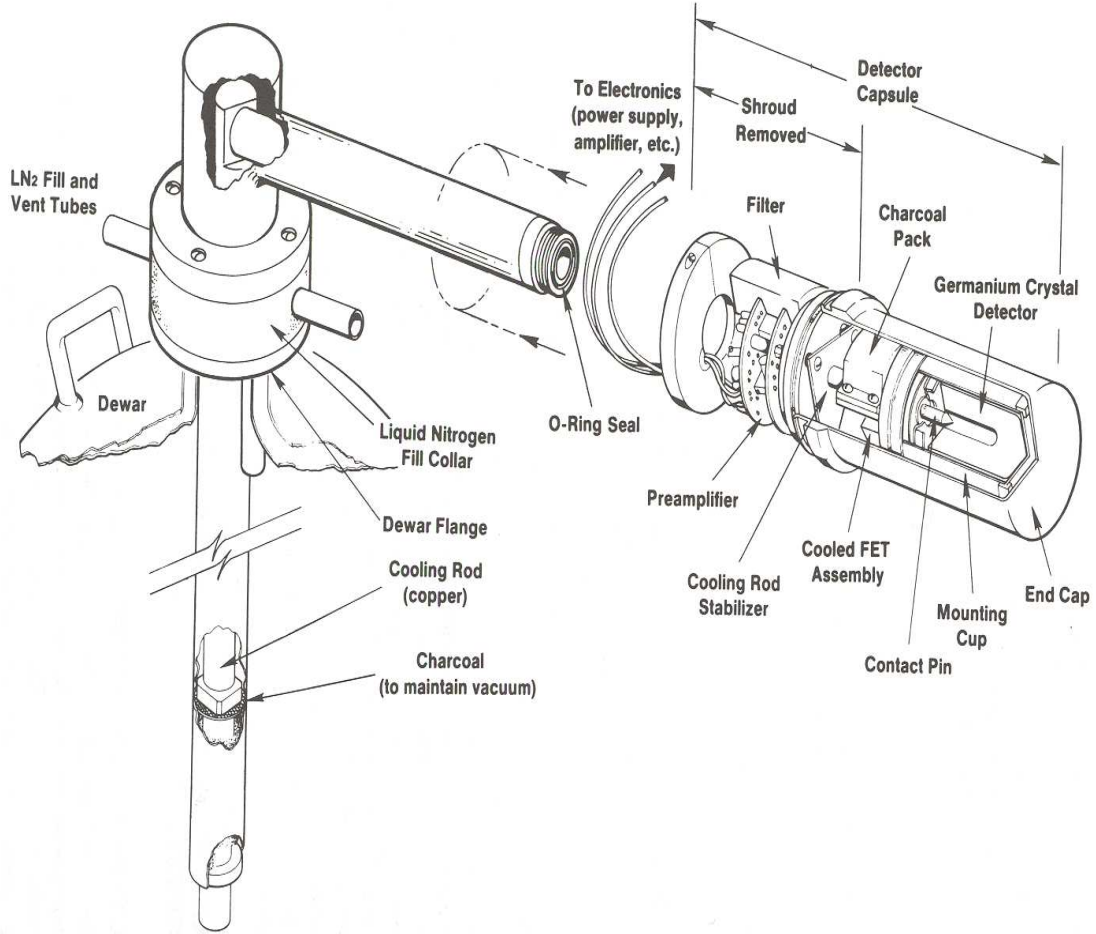
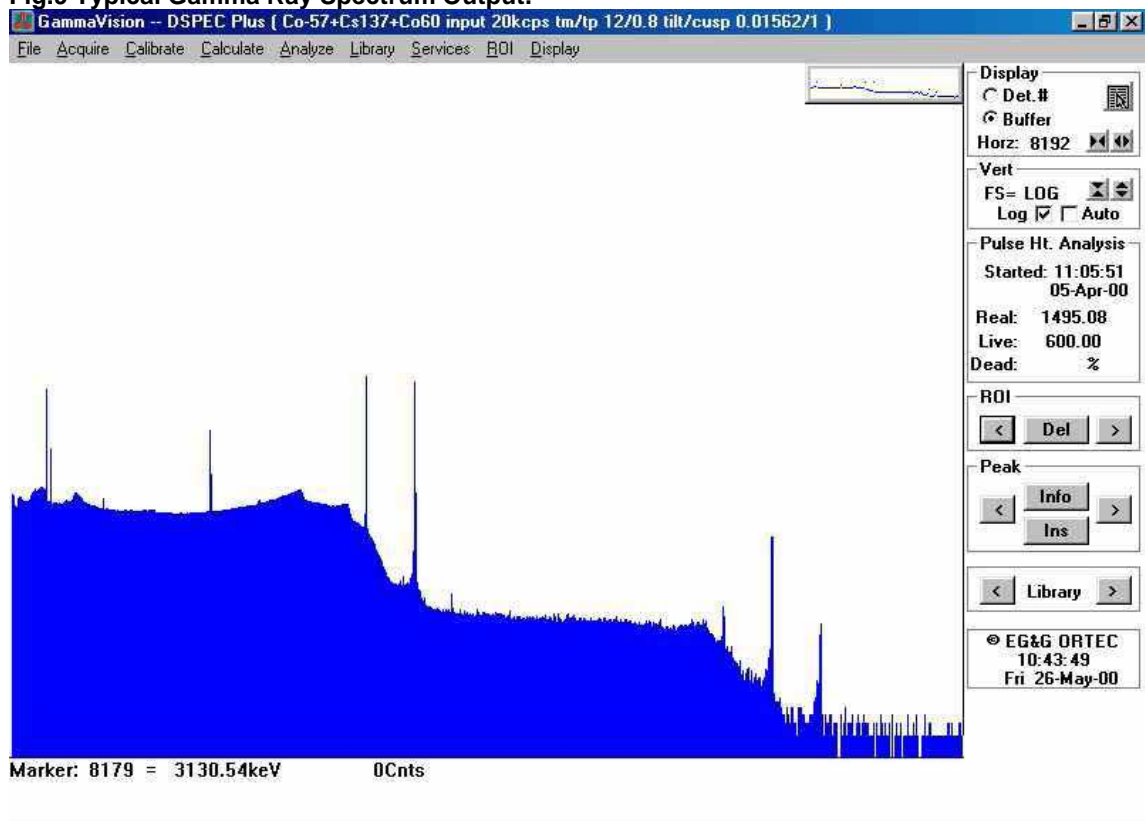
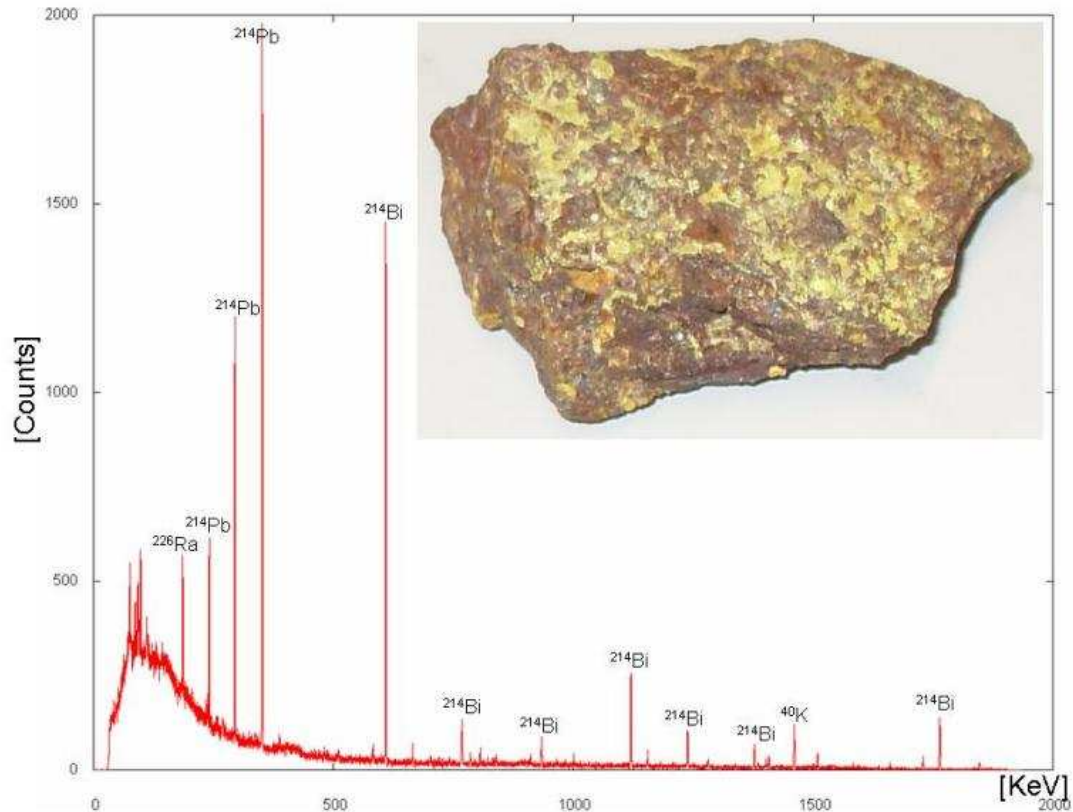

Fig.9 Typical Gamma Ray Spectrum Output.



**Fig.10 The gamma ray spectrum of natural uranium**



### 3.1.1 Gamma ray characteristics

Gamma rays are the highest energy forms of electromagnetic radiation, being physically exactly like all other forms (e.g. X rays, visible light, infrared, radio) except for higher photon energy and frequency and shorter wavelength. (Because of their high energy gamma-ray, photons are generally counted individually, whereas the lowest energy forms of EM radiation (e.g., radio to sub-millimetre) are observed as electromagnetic waves consisting of many low-energy photons.) While a Geiger counter or Gamma Probe determines only the count rate (i.e. the number of gamma rays interacting in the detector in one second) a gamma-ray spectrometer also determines the energies of the gamma-ray photons emitted by the source.

Radioactive nuclei (radionuclides) commonly emit gamma rays in the energy range from a few keV to ~10 MeV, corresponding to the typical energy levels in nuclei with reasonably long lifetimes. Such sources typically produce gamma-ray "line spectra" (i.e. many photons emitted at specific energies), whereas much higher energies (upwards of 1 TeV) may occur in the continuum spectra observed in astrophysics and elementary particle physics. The boundary between gamma rays and X-rays is somewhat blurred, as X-rays typically refer to the high energy EM emission of atoms, which may extend to over 100 keV, whereas the lowest energy emissions of nuclei are typically termed gamma rays, even though their energies may be below 20 keV.

### 3.1.2 System components and principle of operation

The equipment used in gamma spectroscopy includes an energy-sensitive radiation detector, electronics to collect and process the signals produced by the detector, such as a pulse sorter (i.e. multichannel analyser) and associated amplifiers and data readout devices to generate, display and store the spectrum. Other components, such as rate meters and peak position stabilizers, may also be included.

The most common detectors include sodium iodide (NaI) scintillation counters and high-purity germanium detectors.

Gamma spectroscopy detectors are passive materials that wait for a gamma interaction to occur in the detector volume. The most important interaction mechanisms are the photoelectric effect, the Compton effect and pair production. The photoelectric effect is preferred as it absorbs all of the energy of the incident gamma ray.

Full energy absorption is also possible when a series of these interaction mechanisms take place within the detector volume. When a gamma ray undergoes a Compton interaction or pair production, and a portion of the energy escapes from the detector volume without being absorbed, the background rate in the spectrum is increased by one count. This count will appear in a channel below the channel that corresponds to the full energy of the gamma ray. Larger detector volumes reduce this effect.

The voltage pulse produced by the detector (or by the photomultiplier in a scintillation detector) is shaped by a multichannel analyser (MCA). The multichannel analyser takes the very small voltage signal produced by the detector, reshapes it into a Gaussian or trapezoidal shape, and converts that signal into a digital signal. In some systems, the analog-to-digital conversion is performed before the peak is reshaped. The analog-to-digital converter (ADC) also sorts the pulses by their height. ADCs have specific numbers of "bins" into which the pulses can be sorted; these bins represent the *channels* in the spectrum. The number of channels can be changed in most modern gamma spectroscopy systems by modifying software or hardware settings.

The multichannel analyser output is sent to a computer which stores, displays and analyses the data. A variety of software packages are available from several manufacturers, and generally include spectrum analysis tools such as energy calibration, peak area and net area calculation and resolution calculation.

### 3.1.3 Detector performance

Gamma spectroscopy systems are selected to take advantage of several performance characteristics. Two of the most important include detector resolution and detector efficiency.

#### 3.1.3.1 Detector resolution

Gamma rays detected in a spectroscopic system produce peaks in the spectrum. These peaks can also be called *lines* by analogy to optical spectroscopy. The width of the peaks is determined by the resolution of the detector, a very important characteristic of gamma spectroscopic detectors, and high resolution enables the spectroscopist to separate two gamma lines that are close to each other. Gamma spectroscopy systems are designed and adjusted to produce symmetrical peaks of the best possible resolution. The peak shape is usually a Gaussian distribution. In most spectra the horizontal position of the peak is determined by the gamma ray's energy, and the area of the peak is determined by the intensity of the gamma ray and the efficiency of the detector. The most common figure used to express detector resolution is full width at half maximum (FWHM). This is the width of the gamma ray peak at half of the highest point on the peak distribution. Resolution figures are given with reference to specified gamma ray energies. Resolution can be expressed in absolute (i.e. eV or MeV) or relative terms. For example, a sodium iodide (NaI) detector may have a FWHM of 9.15 keV at 122 keV and 82.75 keV at 662 keV. These resolution values are expressed in absolute terms. To express the resolution in relative terms, the FWHM in eV or MeV is divided by the energy of the gamma ray and multiplied by 100. Using the preceding example, the resolution of the detector is 7.5% at 122 keV and 12.5% at 662 keV. A germanium detector may give resolution of 560 eV at 122 keV, yielding a relative resolution of 0.46%.

#### 3.1.3.2 Detector efficiency

Not all gamma rays emitted by the source and pass through the detector will produce a count in the system. The probability that an emitted gamma ray will interact with the detector and produce a count is the *efficiency* of the detector. High-efficiency detectors produce spectra in less time than low-efficiency detectors. In general, larger detectors have higher efficiency than smaller detectors, although the shielding properties of the detector material are also important factors. Detector efficiency is measured by comparing a spectrum from a source of known activity to the count rates in each peak to the count rates expected from the known intensities of each gamma ray.

Efficiency, like resolution, can be expressed in absolute or relative terms. Absolute efficiency values represent the probability that a gamma ray of a specified energy passing through the detector will interact and be detected. Relative efficiency values are often used for germanium detectors, and compare the efficiency of the

detector at 1332 keV to that of a 3 in x 3 in NaI detector (i.e.  $1.2 \times 10^{-3}$  cps/Bq at 25 cm). The energy of the gamma rays being detected is an important factor in the efficiency of the detector. An efficiency curve can be obtained by plotting the efficiency at various energies. This curve can then be used to determine the efficiency of the detector at energies different from those used to obtain the curve. High-purity germanium (HPGe) detectors typically have higher sensitivity.

Germanium detectors are semiconductor diodes having a P-I-N structure in which the intrinsic (I) region is sensitive to ionizing radiation, particularly X-rays and gamma rays. Under reverse bias, an electric field extends across the intrinsic or depleted region. When photons interact with the material within the depleted volume of a detector, charge carriers are produced and are swept by the electric field to the P and N electrodes. This charge, which is in proportion to the energy deposited in the detector by the incoming photon, is converted into a voltage pulse by an integral charge-sensitive pre-amplifier.

Because germanium has a relatively low band gap, these detectors must be cooled in order to reduce the thermal generation of charge carriers (thus reverse leakage current) to an acceptable level. Otherwise, leakage current induced noise destroys the energy resolution of the detector. Liquid nitrogen, which has temperature of  $-196.15$  °C, is the common cooling medium for such detectors. The detector is mounted in a vacuum chamber which is inserted in a liquid nitrogen dewar. The sensitive detector surfaces are thus protected from moisture and other contaminants.

Although Ge detectors can be warmed up when not in use, the lithium-diffused N+ contact is not perfectly stable at room temperature. For this reason it is best to avoid extended warm time, especially for standard-electrode coaxes where the Li contact affects low energy response.

### **3.1.3.3 Calibration and background radiation**

If a gamma spectrometer is used for identifying samples of unknown composition, its energy scale must be calibrated first. Calibration is performed by using peaks of a known source, such as Cs-137 or Co-60. Because the channel number is proportional to energy, the channel scale can then be converted to an energy scale. If the size of the detector crystal is known, one can also perform an intensity calibration, so that not only the energies, but also the intensities of an unknown source, or the amount of a certain isotope in the source, can be determined.

Because radioactivity is present everywhere, the spectrum should be analysed when no source is present. The background radiation must then be subtracted from the actual measurement. Lead castles can be placed around the detector to reduce background radiation. Fig. 11 and Fig. 12 show the lead castles around the detectors. Fig. 11 also shows an electrically cooled detector that does not need liquid nitrogen for cooling. Fig. 12 also shows a detector that uses liquid nitrogen for cooling, as can be seen with the liquid nitrogen filled dewar positioned below the lead castle. Fig.13 shows a lead castle with the detector in position.

**Fig.11. Electrically cooled Gamma detector in a lead castle**



**Fig.12. Liquid Nitrogen cooled Detector in a lead castle**



**Fig.13. Detector inside of lead castle**



## Liquid Scintillation Counting

Liquid Scintillation Counting (LSC) or Liquid Scintillation Analysis (LSA) has been a very popular technique for the detection and quantitative measurement of radioactivity since the early 1950's. It has been most useful in the studies of the life sciences and the environment and is also a powerful tool in the chemical and physical sciences. Many of the principles of LSC overlaps into the fields of low-level environmental radioactivity monitoring, the detection of singular decay events in basic nuclear physics and the measurement of higher levels of radioactivity used in research, radioisotope applications and nuclear power. The LSC technique in scientific research remains one of the most popular experimental tools used for the quantitative analysis of radionuclides. These include principally the analysis of alpha- and beta-particle emitting nuclides.

The wide popularity of LSC is a consequence of numerous advantages, which are high efficiencies of detection, improvements in sample preparation techniques, automation, including computer data processing, and the spectrometer capability of liquid scintillation analysis permitting the simultaneous assay of different radionuclides.

### Basic Theory

The discovery scintillation in organic compounds was documented in a thesis by Lieselott Herforth (1948) under the leadership of Hartmut Kallman, which is related in a historical account by Niese (2003, 1999). In her thesis presented on September 13, 1948 at the Technical University Berlin, Herforth reported that aromatic compounds could convert absorbed energy of nuclear radiation into light photons.

Herforth's thesis and publications were followed by papers authored by Kallman (1950) and Reynolds *et al.* (1950) on LSC that demonstrated certain organic compounds in solution emitted fluorescent light when bombarded by nuclear radiation. The fluorescence or emission of photons by organic compounds (fluors) as a result of excitation can be readily converted to a burst of electrons with the use of a photomultiplier tube (PMT), and subsequently measured as a pulse.

The technique of LSC involves placing the sample containing the radioactivity into the glass or plastic container, called a scintillation vial, and adding a special scintillation cocktail containing the organic fluors dissolved into suitable solvents. The introduction of LSC reduced the time required to analyse radioactive samples from hours to minutes. For low energy ("soft")  $\beta$  emitters, LSC offers unmatched convenience and sensitivity. LSC detects radioactivity via the same type of light emission events which are used in solid scintillation. The key difference is that in LSC the scintillation takes place in a solution of scintillator, rather than in a solid crystal. This allows close contact between the isotope atoms and the scintillator.

Liquid scintillation cocktails absorb the energy emitted by the radioisotopes and re-emit it as flashes of light. To accomplish these two actions, absorption and re-emission, cocktails contain two basic components, the solvent and the phosphor. The solvent carries out the bulk of the energy absorption. Dissolved in the solvent, molecules of phosphor convert the absorbed energy into light. This can be seen in Fig. 14.

Fig.14.The Scintillation Process

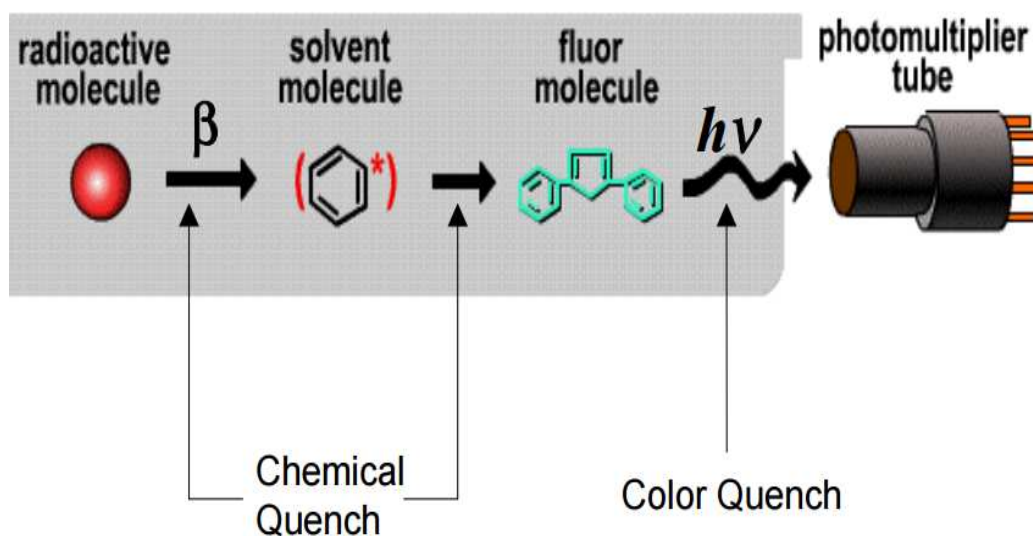

Many cocktails contain additional materials to extend their range of use, but the solvent and phosphor provide the scintillation of the mixture.

Many liquid fluor cocktails are available commercially and these are made to be compatible and mixable with radioactive samples in either organic solvents or aqueous media. When samples are dissolved in aqueous media, three different chemical components are required in the fluor cocktail solution: the organic solvent, organic scintillator and surfactant (emulsifier).

Unique scintillation cocktails may be prepared to meet special detection needs, such as the detection of neutrinos, neutron/gamma discrimination, alpha/beta discrimination and the detection of neutrinos or unique decay events.

Both plastic and glass vials can be used and have certain advantages and disadvantages in terms of background, solvent permeability, fragility and transparency. Polyethylene plastic vials are permeable when stored containing fluor solvents such as benzene, toluene and xylene. The plastic vials are also unbreakable, less expensive and display lower backgrounds than the glass vials. Glass vials provide the advantage of transparency to visualise sample and fluor cocktail solution to permit inspection for undesirable properties such as colour, residue or sample inhomogeneity.

The major use of liquid scintillation counting in power plant operations is to monitor the low-energy beta emitting tritium ( $^3\text{H}$ ) isotope at 18.6 keV. It can also be used for assaying other beta emitting isotopes such as  $^{14}\text{C}$  (E max = 156.5 keV),  $^{32}\text{P}$  (E max = 1710.4 keV),  $^{129}\text{I}$  (E max = 152 keV),  $^{35}\text{S}$  (E max = 167.5 keV),  $^{89}\text{Sr}$  (E max = 1491 keV), and  $^{90}\text{Sr}$  (E max = 546.0 keV). The major advantage of liquid scintillation counting is the increased efficiency for detecting low-energy radiation.

### **Chemical Quench**

Chemical quench occurs during the transfer of energy from the solvent to the scintillator. Any chemical species that is electronegative will affect the energy transfer process by capturing or stealing the pi electrons associated with the aromatic solvent and thus reduces the availability of pi electrons necessary for efficient energy transfer.

### **Colour quench**

Colour quench is an attenuation of the photons of light. The photons produced are absorbed or scattered by the colour in the solution, resulting in reduced light output available for measurement by the photomultiplier tubes. The collective effect of quench is a reduction in the number of photons produced and, therefore, detected CPM (counts per minute). Counting efficiency is affected by the degree of quenching in the sample. To determine the absolute activity in DPM (disintegrations per minute) or absolute activity), it is necessary to measure the level of quench of the samples first, and then make the corrections for the measured reduction in counting efficiencies.

### **Measurement of Quench**

It is possible to measure quench accurately via high-resolution spectral analysis. Quenching manifests itself by a shifting of the energy spectrum towards the lower energy channels in the Multichannel Analyser (MCA). There are two methods of spectral analysis for measuring quench. The first method is Spectral Index of the Sample (SIS), which uses the sample isotope spectrum to monitor the quench of the solution. The SIS value decreases as a quench increases, reflecting the shift of the spectrum to lower energy. The second method used to measure quench is the transformed Spectral Index of the External Standard (t-SIE), which is calculated from the Compton spectrum induced in scintillation cocktail by an external gamma source. This can be seen in Fig.15. The source is positioned under the sample vial, causing a Compton spectrum to be produced in the cocktail solution. From a mathematical transformation of this spectrum, the t-SIE value is determined, and the t-SIE is a relative value from 0 (most quenched) to 1000 (unquenched). The calculated t-SIE value is adjusted to 1000 when the instrument is calibrated. Like SIS the t-SIE value decreases as quench increases. Both SIS and t-SIE are used as Quench Indicating Parameters (QIP's).

Fig.15. Compton Spectrum

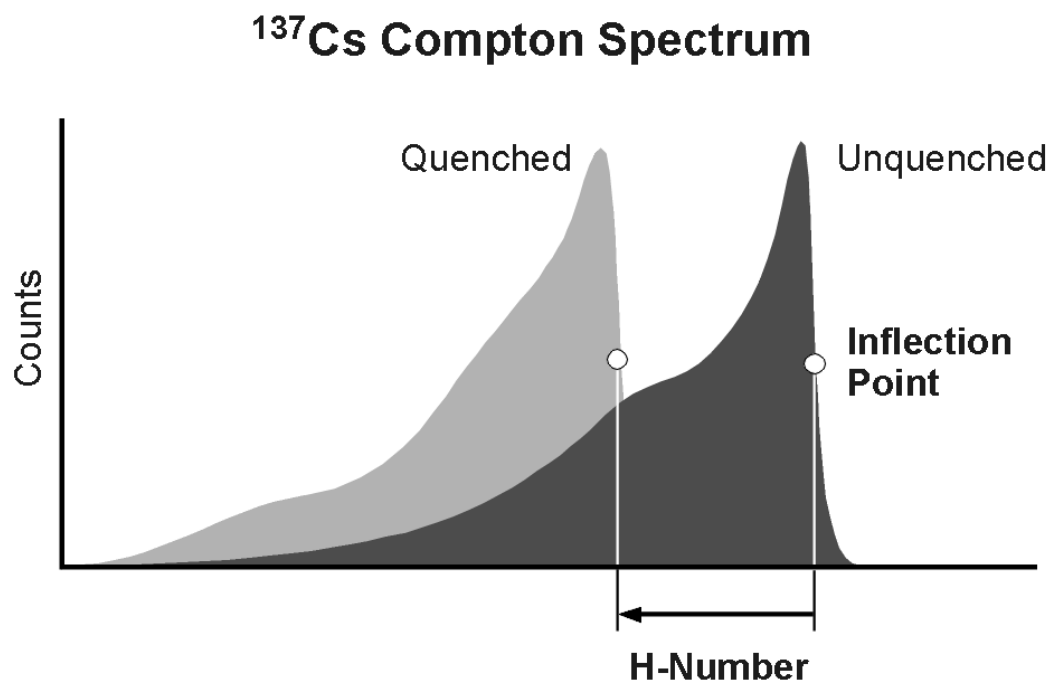

### Quench curves

A quench curve is a series of standards in which the absolute radioactivity (DPM) per vial is constant and the amount of quench increases from vial to vial. A quench curve uses the relationship between counting efficiency and QIP to correct the measured CPM to DPM. When a quench curve is made, the DPM value in each standard is known. Each standard is counted and the CPM is measured. The counting efficiency is calculated using the following relationship:

$$\text{CPM} \times 100 / \text{DPM} = \% \text{ Counting Efficiency}$$

At the same time the QIP is measured for each standard. A correlation is made using the QIP on one axis (X) and the efficiency on the other (Y). A curve is fitted to the standard points. Once the quench curve is stored in the instrument computer, it can be used for automatic DPM calculations. When the unknowns are counted the sample CPM and the QIP are measured. Using the QIP, the counting efficiency is determined from the quench curves. Sample DPM are then calculated by applying the appropriate efficiency to the CPM of the sample.

$$\text{DPM} = \text{CPM} / \% \text{ Efficiency}$$

The standards and unknowns must be counted with the same energy range. Examples of quench curves can be seen in Figures 16 and 17.

Fig.16.  $^3\text{H}/^{14}\text{C}$  Quench Curve

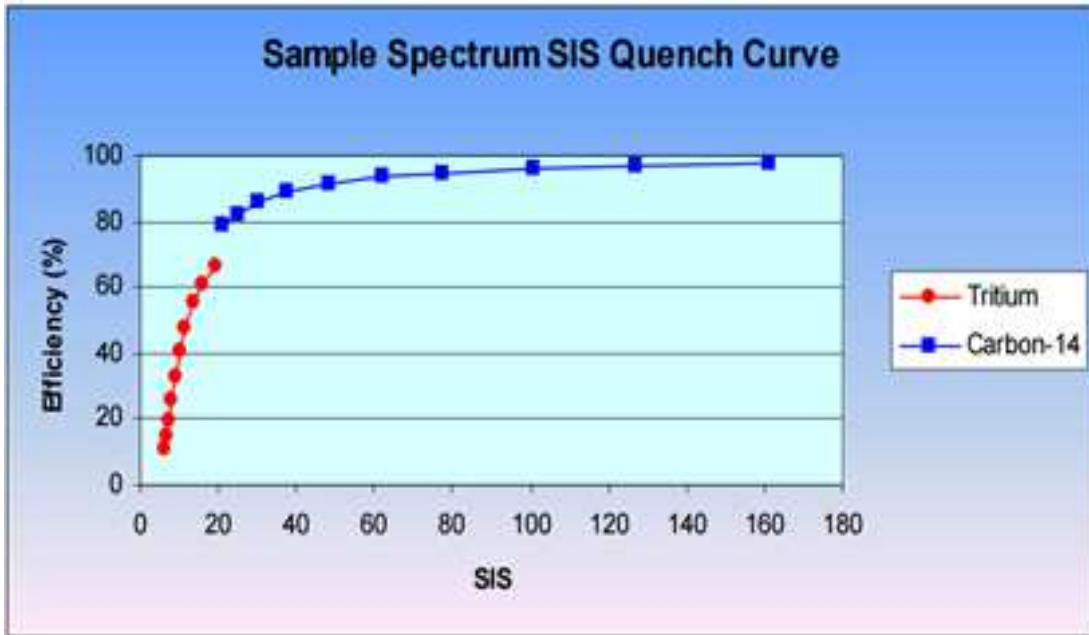
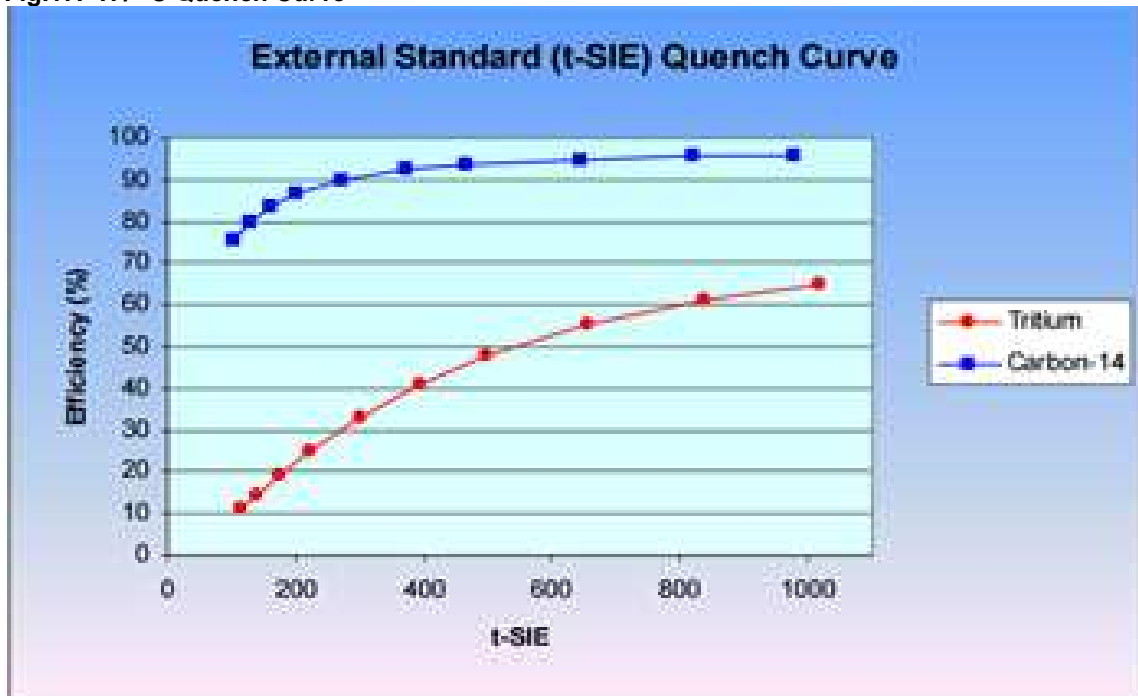

Fig.17.  $^3\text{H}/^{14}\text{C}$  Quench Curve



### **Preparation of quench curves**

A quench standard curve is a series of standards in which the absolute activity per vial is constant and the amount of quench increases from vial to vial. The quench is increased from vial to vial by adding a quenching agent. A quenching agent is any chemical or colour material added to the vial which causes a shift in the standard spectrum to a lower energy and a subsequent decrease in the counting efficiency of the radioactive standard. Usually a series of five to ten standards are prepared per radionuclide. This is also referred to as the quench set.

Some manufacturers provide factory stored quench curves in the instrument for  $^3\text{H}$  and  $^{14}\text{C}$ . It then becomes necessary for the researcher to prepare a quench curve for isotopes other than  $^3\text{H}$  or  $^{14}\text{C}$ . There are some basic considerations for preparing a quench curve:

- It is necessary to obtain a calibrated source of radioactivity to use as the source of activity (DPM)
- It is essential that a known amount of activity be added per vial
- The standard material must be compatible with the cocktail chosen
- A suitable quenching agent must be chosen
- It is advisable to closely approximate the chemical environment in the samples

The quenching agents that are most often used are carbon tetrachloride ( $\text{CCl}_4$ ), acetone ( $\text{CH}_3\text{COCH}_3$ ), chloroform ( $\text{CHCl}_3$ ) and nitromethane ( $\text{CH}_3\text{NO}_2$ ).

### **DPM Determination**

#### Auto DPM

- SL DPM calculation on pure beta- and alpha emitting isotopes
- No need for a quench curve
- Auto DPM can be initiated from a Command Card. This program uses default parameters set by the instrument
- Auto DPM may also be selected as a Data Calculation Program, and initiated with a User Number Card. The parameters set in the user program are used to count the samples

#### Single-, Dual-, and Triple label DPM

- Quench curve library required
- Instrument will have factory stored  $^{14}\text{C}$ , and  $^3\text{H}$  quench curves

- Quench curves need to be set up for isotopes other than  $^{14}\text{C}$  and  $^3\text{H}$
- Background quench curves must also be set up.

Figure 18 is an example of a liquid scintillation counter as used at KNPS.

**Fig.18. LS 6500 Multipurpose Liquid Scintillation Counter as used at KNPS**



## 3.2 iMatic™ Gas-less Automatic Alpha/Beta Counting System

### 3.2.1 Description

The CANBERRA iMatic™ is a firmware based, automatic, low background, gas-less alpha/beta counter designed specifically for the analysis of air filters and smear or swipe samples. The iMatic discriminates both radon isotopes and their progeny from transuranic and fission product materials on the samples. It uses a solid state silicon PIPS detector for alpha and beta detection; can be operated continually for over six hours with internal batteries and is totally self-contained. The iMatic represents a major technological breakthrough in air filter analysis.

The iMatic provides reliable measurements of transuranic and fission product activity on filter samples in the presence of radon interferences. Using a patent pending technique, the iMatic applies auto-adaptive spectrometric compensation for the radon interferences.

The iMatic radon compensation algorithm adjusts to all types of filter media from glass fibre filter media for smear analysis to Millipore® membrane type filter media for air sampling. The iMatic adapts to these different filter media types *automatically*. No additional calibrations or special instrument settings are required. Two built-in, operator-adjustable alpha and beta alarm levels are provided to alert the operator when a critical limit has been exceeded.

The iMatic anti-coincidence guard detector provides rejection of external gamma and cosmic radiation to minimize the overall system alpha and beta background.

The anti-coincidence guard detector utilizes a customized 'wrap around' plastic scintillator. The guard detector surrounds the sample detector optimizing the rejection of low angle external gamma and cosmic events. The light pulses generated within the scintillator are coupled to a photomultiplier tube where the light is converted into an electrical signal that is used to anti-coincidence gate the data collection of PIPS sample detector events. When throughput and sensitivity are essential, the iMatic is unsurpassed.

The iMatic provides the system operator with gross alpha/beta results. Pulses from detected charged particles are sorted by energy. A lower level discriminator is set at 125 keV and any particle with energy greater than this threshold but less than 2.2 MeV is identified as a beta. A particle with energy greater than 3 MeV and less than or equal to 9.6 MeV is identified as an alpha. The 3 MeV to 6.4 MeV portion of the alpha region is further divided into three overlapping regions; a uranium region, an

americium/plutonium region and a curium region. These regions allow the user to reasonably determine which nuclide is present in a sample if a high compensated alpha result is encountered. The following regions may be selected to be reported on the iMatic hardcopy printout. Energy values are approximate.

- Total Alpha Region: 3.0 MeV to 9.6 MeV
- Uranium Region: 3.0 MeV to 5.0 MeV
- Uranium, Am and Pu Region: 3.0 MeV to 5.6 MeV
- Curium Region: 3.0 MeV to 6.4 MeV
- Total Beta Region: 125 keV to 2.2 MeV

### 3.2.2 Features

- Automatic sample changer with 50 or 100 sample capacity
- Automatically identifies and compensates for radon, thoron and progeny interference
- PIPS<sup>®</sup> silicon GAS-LESS detector
- Developed primarily for air filter analysis
- NiMH battery power provides 6+ hours of continuous operation
- Universal, auto-sensing power supply
- Scintillation cosmic guard detector
- Moulded low background passive lead shielding with interlocking design, 4 in. thick
- Compatible with essentially all filter types and sizes from 25 mm to 60 mm diameter
- Carriers available for NFS,PAS and SAS mounted filters
- Includes mobile cart
- Stores up to twenty-six standards; allows for up to ten counting procedures and ten independent calibrations
- Automatic system calibration for background, alpha and beta efficiencies for all ten calibrations with no operator intervention
- Automatic daily QC checks of alpha and beta backgrounds and alpha and beta efficiencies

Fig 19 shows iMatic alpha/beta counter as used at KNPS.

**Fig.19. IMatic alpha beta counter as used at KNPS**



## CHAPTER 4 EXPERIMENTAL

### 4.1 Calibration of instruments - HPGe Gamma Detector

#### Apparatus and Materials

- Germanium Detector
- A multinuclide standard solution of a source obtained from Eckert & Ziegler;
- This multinuclide is in a 2 M HCl medium and has an activity of about 380 kBq.
- Pipettes
- Glass beakers

The detector was commissioned and the hardware set-up was completed. For the energy calibration, gamma ray sources of known gamma ray energies ranging over the energies that need to be detected are used. At least five gamma rays, spread approximately evenly over the energy range were used. This can be seen in Fig.20.

For efficiency calibrations, a mixed gamma source of known gamma ray energies and activities is used. Gamma ray energies should cover as much of the energy spectrum as possible. This can be seen on the gamma source certificate in Fig.21.

#### 4.1.2 Calibration of iMATIC alpha/beta detector

##### Materials and Apparatus

A standardised solution of Sr-90/Y-90, obtained from Eckert & Ziegler;

I-Matic alpha/ beta counter

Planchettes

Glass beakers

Pipettes

Sr-spec resin

8 M HNO<sub>3</sub>

0.05 M HNO<sub>3</sub>

##### 4.1.2.1 Preparation of pure <sup>90</sup>Sr and <sup>90</sup>Y Calibration sources

- 4.1.2. Add an appropriate volume of calibrated Sr-90 standard solution to a beaker, add 1 mL of Sr carrier and evaporate the solution to dryness.
- 4.1.2.2 Redissolve the residue in 10 mL of 8 M HNO<sub>3</sub>.
- 4.1.2.3 Pack a resin column with 0.7 g of Sr-Spec resin. Condition the resin with 5 mL of 8 M HNO<sub>3</sub>.

- 4.1.2.4 Transfer the redissolved residue into the Sr-resin column using a plastic pipette.
- 4.1.2.5 Add 5 mL of 8 M HNO<sub>3</sub> to rinse the beaker and transfer into the Sr-Spec resin column.
- 4.1.2.6 Add 5 mL of 8 M HNO<sub>3</sub> to the Sr Resin column and allow to drain.
- 4.1.2.7 Combine the effluent from the column to determine the <sup>90</sup>Y counting efficiency.
- 4.1.2.8 Add 10 mL of 0.05 M HNO<sub>3</sub> to the column to elute the Sr.
- 4.1.2.9 Prepare the <sup>90</sup>Sr as appropriate for use as a calibration standard, ie. Evaporation on a planchette.
- 4.1.2.10 Prepare the <sup>90</sup>Y from the column effluent for use as a calibration standard
  - Evaporate the <sup>90</sup>Y fraction to dryness
  - Add 2 mL of 65% HNO<sub>3</sub> and 5 drops of 25% H<sub>2</sub>O<sub>2</sub> to decompose the organic material from the Sr resin column.
  - Dissolve the residue in 10 mL of 0.05 M HNO<sub>3</sub>.

### 4.1.3 Calibration of Beckman Liquid Scintillation Counter

#### Materials and Apparatus

A standardised solution of Sr-90/Y-90, obtained from Eckert & Ziegler;

Beckman coulter Liquid Scintillation Counter

Glass Vials

Pipettes

#### 4.1.3.2 Preparation of Pure <sup>90</sup>Sr and <sup>90</sup>Y Calibration sources

- 4.1.3.1 Add a few µL of a known activity of <sup>90</sup>Sr standard solution, 1 mL of Sr and Y carrier (10 mg/mL) into a 50 mL beaker.
- 4.1.3.2 Add 10 mL 3 M (or 8 M) HNO<sub>3</sub>
- 4.1.3.3 Load the solution on the Sr-resin column (3.0 g Sr-resin column), preconditioned in advance with 100 mL of 3 M HNO<sub>3</sub> (or 8 M)
- 4.1.3.4 Wash the column with 50 mL of 8 M HNO<sub>3</sub>
- 4.1.3.5 Combine the effluent from the column for determining the <sup>90</sup>Y counting efficiency.
- 4.1.3.6 Elute the Sr from the column with 30 mL 0.05 M HNO<sub>3</sub>.
- 4.1.3.7 After addition of 400 mg of oxalic acid, adjust the pH of the solution to between 9 and 10 with 25% NH<sub>4</sub>OH (for oxalate precipitation).

- 4.1.3.8 After addition of 5 mL of saturated  $(\text{NH}_4)_2\text{CO}_3$ , adjust pH of the solution to about 7 with 25%  $\text{NH}_4\text{OH}$  (for carbonate precipitation).
- 4.1.3.9 Heat the solution on a hotplate for a few minutes.
- 4.1.3.10 After cooling the solution, filter through a pre-weighed filter paper.
- 4.1.3.11 Wash the precipitate with a few mL of ethanol then dry at 65 °C for 30 minutes.
- 4.1.3.12 Determine the chemical recovery of Sr by the gravimetric method.
- 4.1.3.13 Prepare the  $^{90}\text{Y}$  from the column effluent for use as a calibration standard as follows:
- Evaporate the  $^{90}\text{Y}$  fraction to dryness
  - Add 2 mL of 65%  $\text{HNO}_3$  and 5 drops of 25%  $\text{H}_2\text{O}_2$  to decompose the organic material originating from the Sr-resin column.
  - Dissolve the residue in 10 mL of 0.05 M  $\text{HNO}_3$ .

## 4.2 Alternative quench calibration for $^{90}\text{Sr}$ and $^{90}\text{Y}$ measurements

- 4.2.1 The counting efficiency of each of each  $^{90}\text{Sr}$  and  $^{90}\text{Y}$  with a particular quench level must be measured for determining the individual activity of  $^{90}\text{Sr}$  and  $^{90}\text{Y}$ . Quench calibration was done by counting a quench series of reference standards for  $^{90}\text{Sr}$  and  $^{90}\text{Y}$ .
- A known amount of  $^{90}\text{Sr}$  was separated from  $^{90}\text{Sr}/^{90}\text{Y}$  standardised solution using Sr-spec column.
  - Column was conditioned with 20 mL 8 M  $\text{HNO}_3$ .
  - Standardised solution was loaded into the column.
  - Column was washed with 20 mL of 8 M  $\text{HNO}_3$ .
  - The washing and loading solutions containing the  $^{90}\text{Y}$  were collected and evaporated to dryness to avoid chemical/colour quenching due to the nitrate anion.
  - $^{90}\text{Sr}$  was stripped with 8 mL of 0.05 M  $\text{HNO}_3$  and collected in a vial.
  - The quenching agent was added to each vial in increasing amounts (0-500  $\mu\text{L}$ ).
  - $^{90}\text{Y}$  standards were prepared in the same way as the Sr-90.
  - Parallel experiments for  $^{85}\text{Sr}$  separation were done to determine recovery.

## Experimental

### 4.3 Determination of total Sr in liquid effluent samples

Summary of Method:

Radioactive Sr is separated using Sr-Resin prior to gas proportional counting, liquid scintillation counting or Cerenkov counting. Stable strontium and/or Sr-85 tracer are used to monitor method yields and correct results to improve precision and accuracy.

This method is a rapid, reliable method for the measurement of strontium in water samples.

#### 4.3.1 Apparatus

- Beta detector – gas proportional counter, liquid scintillation counter
- Ion exchange columns – 1 to 1.5 cm diameter, 0.7 mL resin volume
- Fume hood
- Hot plate
- Liquid scintillation vials
- Gamma detector – <sup>85</sup>Sr tracer only

#### 4.3.2 Reagents

- Liquid scintillation cocktail
- Nitric acid (15.7 M) – concentrated nitric acid
- Nitric acid (3 M)
- Nitric acid (3 M) – Oxalic acid (0.05 M)
- Nitric acid (0.05 M)
- Nitric acid (0.1 M)
- Nitric acid solution (8 M)
- Sr- Resin
- <sup>85</sup>Sr tracer
- Sr – carrier (5 mg/mL)

#### 4.3.3 Preparation of water samples

4.3.3.1 Use 500 mL of sample. Acidify this sample to pH 2 using concentrated nitric acid.

4.3.3.2 Add 1 mL of 5 mg/mL Sr-carrier to sample.

4.3.3.3 Evaporate sample to dryness to concentrate Sr.

#### 4.3.4 Sr – Resin column preparation

**NOTE:** For this experiment 5 mL medical syringes, with a sinter at the bottom, were used as columns

4.3.4.1 Soak the resin for at least an hour in demineralised water before packing column.

4.3.4.2 Pack each column with 0.7 g of Sr-Spec resin.

4.3.4.3 Wash the resin column with 10 mL of demineralised water.

4.3.4.4 Condition the resin with 10 mL of 8 M HNO<sub>3</sub>.

#### 4.3.5 Sr- Resin Column Separation

4.3.5.1 Dissolve the residue from 4.3.3.3 in 10 mL of 8 M HNO<sub>3</sub>.

4.3.5.2 Transfer re-dissolved sample into Sr-Resin column using a pipette and allow to drain.

4.3.5.3 Add 5 mL 8 M HNO<sub>3</sub> to rinse beaker, and transfer to Sr-resin column and allow to drain.

4.3.5.4 Add 5 mL of 3 M HNO<sub>3</sub> – 0.05 M oxalic acid into column and allow to drain. This step will get rid of Pu<sup>4+</sup> or Ce<sup>4+</sup> that may be present in the sample.

4.3.5.5 Add 5 mL of 8 M HNO<sub>3</sub> to the resin column and allow to drain. This additional 8 M HNO<sub>3</sub> removes any residual oxalic acid and ensures full removal of K<sup>+</sup> and Ba<sup>2+</sup> that may be present in the sample.

4.3.5.6 Record the time when the last rinse completely drains through the column as the start of the Y ingrowth.

4.3.5.7 Ensure that a labelled plastic vial is below the column.

4.3.5.8 Pipette 10 mL of 0.05 M HNO<sub>3</sub> into each column to elute the Sr.

4.3.5.9 Pipette 5 mL of 0.05 M HNO<sub>3</sub> into the column to keep the resin wet during the ingrowth period.

#### 4.3.6 Counting of Samples

4.3.6.1 For each sample analysed, clean a counting dish by moistening a paper towel with ethanol, wiping the dish and letting it dry

4.3.6.2 Weigh the counting dish on an analytical balance and record the weight.

4.3.6.3 Place each counting dish under a heat lamp in a fume hood.

4.3.6.4 Evaporate the column strip solution onto the counting dish in successive 3 mL volumes.

- 4.3.6.5 Allow each 3 mL volume to evaporate to near dryness between additions.
- 4.3.6.6 Rinse the vial containing strip solution with 2 mL of 0.05 M HNO<sub>3</sub> and transfer to counting dish.
- 4.3.6.7 After all the solution has evaporated to dryness, cool the counting dish.
- 4.3.6.8 Re-weigh the counting dish and record the weight.

#### **4.4 Determination of Total Sr in Environmental samples**

##### **Summary of Method**

The method consists of three basic steps: oxalate precipitation to remove the bulk potassium, chromatographic separation of strontium from most inactive and radioactive interferences utilising a crown ether, oxalate precipitation of strontium to evaluate the chemical yield. The radiostrontium is then determined by liquid scintillation counting of the dissolved precipitate.

##### **4.4.1 Apparatus**

- Beta detector – gas proportional counter, liquid scintillation counter
- Ion exchange columns – 1 to 1.5 cm diameter, 3 mL resin volume
- Fume hood
- Hot plate
- liquid scintillation vials
- Gamma detector – <sup>85</sup>Sr tracer only

##### **4.4.2 Reagents**

- Liquid scintillation cocktail
- Nitric acid (15.7 M) – concentrated nitric acid
- Nitric acid (3 M)
- Nitric acid (3 M) – Oxalic acid (0.05 M)
- Nitric acid (0.05 M)
- Nitric acid (0.1 M)
- Nitric acid solution (8 M)
- Sr- Resin
- <sup>85</sup>Sr tracer
- Sr – carrier (5 mg/mL)

#### 4.5 Preparation of Environmental samples

##### Soil, Sediment and Sludge samples:

- 30 g dry sample
- Drying and ashing (400°C)
- Leaching with 1 M HNO<sub>3</sub>, or total dissolution
- Dilution
- Ca-Oxalate precipitation at pH 5.5
- Oxalate destruction by wet ashing (conc HNO<sub>3</sub>, H<sub>2</sub>O<sub>2</sub>)
- Redissolution in 8 M HNO<sub>3</sub>

##### Vegetation

- Drying and homogenisation
- Ashing (400 - 500°C)
- Leaching with 1 M HNO<sub>3</sub>
- Ca/Sr-Oxalate precipitation at pH 5 - 6
- Oxalate destruction (wet ashing or furnace)
- Dissolution in 8 M HNO<sub>3</sub>

- 4.5.1 Add 3 g of sample to a 400 mL glass beaker and 1 mL of Sr- carrier and put on a hotplate.
- 4.5.2 Add 5 mL of concentrated HNO<sub>3</sub> and 5 mL of HF and evaporate to near dryness.
- 4.5.3 Add 5 mL of concentrated HNO<sub>3</sub>, 5 mL of HF and 5 mL of HCl and evaporate to near dryness.
- 4.5.4 Add 5 mL of concentrated HNO<sub>3</sub> to sample to convert it back to the nitrate form, and evaporate to near dryness.
- 4.5.5 Dissolve the residue in 60 mL of 1 M HNO<sub>3</sub> and filter on a 0.45 µm filter to separate strontium and other alkaline metals from silicate and other interferences.
- 4.5.6 Heat the filtrate to near boiling.
- 4.5.7 Add 3 - 4 g of oxalic acid, and adjust the pH to between 5.5 and 6 with NaOH.
- 4.5.8 This suspension is added to a centrifuge tube and centrifuged for 10 min at 3000 rpm.
- 4.5.9 Discard the supernatant. The oxalate precipitate is washed with 15 mL of demineralised water.
- 4.5.10 Dissolve the precipitate in a minimum amount of concentrated HNO<sub>3</sub>, and evaporate to near dryness to remove the oxalate.
- 4.5.11 This residue is dissolved in 30 mL of 8 M HNO<sub>3</sub> and is ready to be added to the Sr-resin column.

## Separation

- Loading solution in general in 8 M or 3 M HNO<sub>3</sub>
- Volume of loading solution depending on:
  - Column size
  - Sr content
  - Matrix (Ca Content)
- Column sizes normally used:
  - 2 mL prepacked (0.65 g resin) for water samples and urine samples;
  - 5 mL prepacked (1.6 g resin) for waste water and some food stuffs;
  - 8 mL prepacked (2.6 g resin) for soil and milk;
  - 10-15 mL (3 - 5 g resin) for all matrices

## 4.6 Extraction

- 4.6.1 Add the full quantity of the dissolved residue to 3 g of Sr-resin column and allow to drain
- 4.6.2 Wash the column with 40 mL of 3 M HNO<sub>3</sub>
- 4.6.3 Wash the column with 40 mL of 3 M HNO<sub>3</sub> – 0.05 M oxalic acid
- 4.6.4 Wash the column with 40 mL of 8 M HNO<sub>3</sub>
- 4.6.5 Elute the Sr with 30 mL of 0.05 M HNO<sub>3</sub>
- 4.6.6 Heat the Sr fraction to near boiling and add 400 mg of oxalic acid
- 4.6.7 Adjust the pH to between 9 and 10 with 25% NH<sub>3</sub>
- 4.6.8 Heat again for 5 minutes to allow strontium oxalate precipitate to form

**Alternatively:** Adjust the pH of the Sr-90 strip solution to about 7 with 25% NH<sub>4</sub>OH

Add 5 mL of saturated (NH<sub>4</sub>)<sub>2</sub>CO<sub>3</sub> to the solution while stirring to form SrCO<sub>3</sub> precipitate.

- 4.6.9 Cool sample and filter through a Buchner funnel on a pre-weighed filter paper.
- 4.6.10 Dry filter paper with precipitate in an oven, cool filter paper after drying and weigh.

## FLOWCHART

### SAMPLE DIGESTION

Fusion technique (1 h)  
Microwave oven (1 day)  
Hotplate  
Leaching (1 day)  
Full digestion (3 days)

**Analytes**

Si, Al, Fe, Ca, Ba, Mg, Pb,  $^{90}\text{Sr}$ ,  
 $^{89}\text{Sr}$ ,  $^{134}\text{Cs}$ ,  $^{137}\text{Cs}$ ,  $^{40}\text{K}$ ,  $^{90}\text{Y}$ .

### CO-PRECIPIATION

Ca-oxalate co-precipitation (1 h)

Ca, Ba, Mg, Pb,  $^{89}\text{Sr}$ ,  $^{90}\text{Sr}$

### EXTRACTION CHROMATOGRAPHY

Separation of Sr using Sr-resin (3h)

$^{89}\text{Sr}$ ,  $^{90}\text{Sr}$

### CHEMICAL RECOVERY

Gravimetry after Sr-carbonate (1h)  
 $^{85}\text{Sr}$  tracer

### MEASUREMENT

Cerenkov mode  
Counting of  $^{89}\text{Sr}$ ,  $^{90}\text{Sr}$   
Scintillation mode  
Alpha/beta counter

## 4.7 Method Validation

### 4.7.1 Environmental Samples

$^{85}\text{Sr}$  was used as a tracer, and samples were spiked and recovery determined by Gamma spectrometry. An appropriate amount of sample was used that corresponds with calibrated geometries on Gamma spectrometer.

- 4.7.1.1 Add 3 g of sample to a 400 mL glass beaker and 1 mL of Sr- carrier and place on a hotplate.
- 4.7.1.2 Add 5 mL of concentrated  $\text{HNO}_3$  and 5 mL of HF and evaporate to near dryness.
- 4.7.1.3 Add 5 mL of concentrated  $\text{HNO}_3$ , 5 mL of HF and 5 mL of HCl and evaporate to near dryness
- 4.7.1.4 Add 5 mL of concentrated  $\text{HNO}_3$  to the sample to convert it back to the nitrate form and evaporate to near dryness.
- 4.7.1.5 Dissolve the residue in 60 mL of 1 M  $\text{HNO}_3$  and filter on a 0.45  $\mu\text{m}$  to separate strontium and other alkaline metals from silicate and other interferences.
- 4.7.1.6 Heat the filtrate to near boiling and add appropriate amount of  $^{85}\text{Sr}$  source.
- 4.7.1.7 Determine the activity of sample.
- 4.7.1.8 Add 3 - 4 g of oxalic acid and adjust the pH to 5.5 – 6 with NaOH.
- 4.7.1.9 This suspension is added to a centrifuge tube and centrifuged for 10 min at 3000 rpm.
- 4.7.1.10 Determine the activity of precipitate.
- 4.7.1.11 Determine the activity of the supernatant.
- 4.7.1.12 The oxalate precipitate is washed with 15 mL of demineralised water.
- 4.7.1.13 Dissolve the precipitate in a minimum amount of concentrated  $\text{HNO}_3$ , and evaporate to near dryness to remove the oxalate.
- 4.7.1.14 This residue is dissolved in 30 mL of 8 M  $\text{HNO}_3$  and is ready to be added to the Sr-resin column.

### 4.7.2 Effluent samples

- 4.7.2.1 Use 10 mL of the sample. Acidify this sample to pH 2 using concentrated  $\text{HNO}_3$ .
- 4.7.2.2 Add 1 mL of  $^{85}\text{Sr}$  source to the sample.
- 4.7.2.3 Measure the total activity on Gamma spectrometry system.

- 4.7.2.4 Evaporate the sample to dryness and dissolve the residue in 10 mL of 8 M HNO<sub>3</sub>.
- 4.7.2.5 Transfer the redissolved sample into 0.7 g Sr-Resin column using a pipette and drain.
- 4.7.2.6 Add 5 mL 8 M HNO<sub>3</sub> to rinse the beaker and transfer to the Sr-resin column and drain.
- 4.7.2.7 Add 5 mL of 3 M HNO<sub>3</sub> – 0.05 M oxalic acid into the column and allow to drain. This step will get rid of the Pu<sup>4+</sup> or Ce<sup>4+</sup> that may be present in the sample.
- 4.7.2.8 Add 5 mL of 8 M HNO<sub>3</sub> to the resin column and allow to drain. This additional 8 M HNO<sub>3</sub> removes any residual oxalic acid and ensures full removal of K<sup>+</sup> and Ba<sup>2+</sup> that may be present in the sample.
- 4.7.2.9 Ensure that a labelled plastic vial is below the column.
- 4.7.2.10 Pipette 10 mL of 0.05 M HNO<sub>3</sub> into each column to elute the Sr.
- 4.7.2.11 Count this sample on the Gamma spectrometry system to determine recovery of <sup>85</sup>Sr.

## CHAPTER 5 – RESULTS AND DISCUSSION

### 5.1 Calibrations

#### 5.1.1 Gamma Detector

A full energy calibration was performed on the detector. For this a set of point sources were used to perform the energy calibration. The sources range in energy from 59 keV to 1836 keV. These sources are  $^{241}\text{Am}$ ,  $^{81}\text{Ba}$ ,  $^{152}\text{Eu}$ ,  $^{137}\text{Cs}$ ,  $^{88}\text{Y}$  and  $^{60}\text{Co}$ . The gamma detector was successfully calibrated for energy over this range. The energy calibration curve is shown in Fig 21.

After a successful energy calibration, the detector was then calibrated for efficiency for each of the geometries routinely used at the KNPS. Efficiency calibration sources were first prepared for each of the geometries from the multinuclide standard obtained from Eckert and Ziegler. An efficiency calibration report can be seen in Fig 22, showing the range of energies covered. It also showed a description of the geometry, as well as date and time the calibration was performed. Fig 23 showed an efficiency calibration curve.

All the efficiency calibrations performed at KNPS needed to be validated. To accomplish this a different batch calibration source of the same geometry is counted. The error between the true value and results obtained should not exceed 20%. All efficiency calibrations performed were found to be within this tolerance. An example of this can be seen in Fig.24. Fig.25 showed an efficiency calibration record which is kept for life at the station.

#### 5.1.2 Calibration of *Matic*

The *Matic* / alpha-beta counter has always been used at KNPS to analyse for  $^{90}\text{Sr}$  in liquid effluent samples making use of the fuming nitric acid method. Calibration of the *Matic* using the fuming nitric acid method, on average yields an efficiency of about 20%, as can be seen in Fig.27. The calibration report in Fig.28 shows a higher efficiency on the *Matic* using the Sr-Spec resin. This method is rapid, safer, since no fuming nitric acid is used, and eliminates the many precipitation steps with the fuming nitric acid method, which could lead to loss of analyte.

#### 5.1.3 Calibration of Liquid Scintillation Counter

Alternative method of calibration was used to calibrate the liquid scintillation counter.

Standards had to be prepared for the calibration of the liquid scintillation counter. As per literature a set consists of ten standards. Ideally ten standards must be used, and at a minimum five standards can be used so as to obtain a good quench curve. Standards sets obtained from suppliers contain at least 180 000 dpm, to avoid long counting times. It was discovered during this work that many manufacturers do not supply standard sets for  $^{90}\text{Sr}$ . Most manufacturers only supply  $^3\text{H}$  and  $^{14}\text{C}$  standards for LSC calibrations. For nuclides other than  $^3\text{H}$  and  $^{14}\text{C}$ , standards will have to be prepared by the researcher.

A  $^{90}\text{Sr}$  source was used to prepare the standards. Only 5 standards could be prepared due to a limited amount of source. The standards contained increasing

amounts of quenching agent. Acetone was used as quenching agent. The source also contained significantly lower dpm's, and as a result counted for much longer. An efficiency of about 25% was obtained for the LSC. For implementation of the Sr-Spec resin method at Koeberg, a stronger source with much higher dpm's will need to be procured, so that the standards can be prepared in the laboratory, since these are not supplied for nuclides other than  $^3\text{H}$  and  $^{14}\text{C}$ .

## 5.2 Environmental samples Results and Discussion

Samples were spiked with  $^{85}\text{Sr}$  and counted on a gamma counter. This was done to determine the recovery of  $^{85}\text{Sr}$  and to test the effectiveness of the method. This method of validation was used in the absence of standard reference materials. For both methods consistent recoveries of about 80% were obtained, as can be seen in Table 6.1 and Fig.30. Recoveries could be increased by possibly increasing the elution volumes. The one outlier where 72% recovery was obtained, was due to spillage of the sample during the experiment. In this example a soil sample was used to verify effectiveness of the method. After ascertaining the initial activity, oxalic acid was added to the sample, and the pH was adjusted to 5.5 – 6. The suspension was centrifuged, after which the activity of both the precipitate and supernatant was ascertained. As per Table 6.1 and Fig.30, most of the activity is contained in the precipitate, due to the Sr-oxalate precipitate that formed, and all the other analytes remained in solution, K in particular which is a major constituent in soil, and could lead to interference if not effectively separated, since the resin also has a high affinity for K.

**Table 6.1 Environmental samples**

	ACTIVITY				% Sr-85 extracted
	Initial	Precipitate	Liquid	Final	final/initial
Sample 1	1.33E+11	1.16E+11	3.84E+09	1.08E+11	8.12E+01
Sample 2	1.31E+11	1.15E+11	6.38E+09	9.50E+10	7.25E+01
Sample 3	1.29E+11	1.12E+11	4.64E+09	1.11E+11	8.60E+01
Sample 4	1.25E+11	1.12E+11	5.19E+09	1.06E+11	8.48E+01

**Fig.30 Environmental samples**

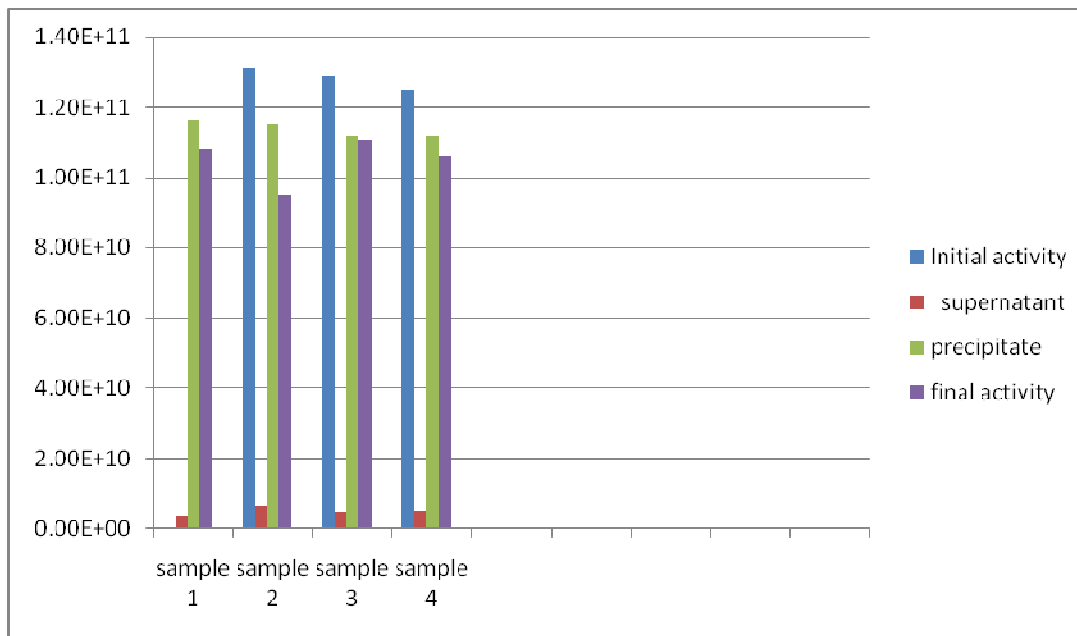

**5.3 Effluent samples**  
**Results and Discussion**

The same check was performed for effluent samples as for the environmental samples. These sample were also spiked with <sup>85</sup>Sr and recoveries ascertained on a gamma detector. The initial activity was ascertained before loading the solution onto the resin column. This solution was then loaded onto the column. The resin column was washed with 3 M HNO<sub>3</sub>/0.05 M oxalic acid. The activity in this wash solution was ascertained. The column was washed again with 8 M HNO<sub>3</sub>, and this activity was also verified. Finally the <sup>85</sup>Sr was eluted with 0.05 M HNO<sub>3</sub>, and this activity was also determined.

As can be seen in Table 6.2.1 and Fig.31, most of the <sup>85</sup>Sr was retained on the resin and recoveries of about 83% were obtained.

**Table 6.2.1 Effluent samples**

Sample	Initial	Wash 1	Wash 2	Final act.
1	3.88E+10	2.17E+07	5.88E+07	3.22E+10
2	2.15E+11	N/D	1.35E+08	1.78E+11

**Fig.31 Effluent samples**

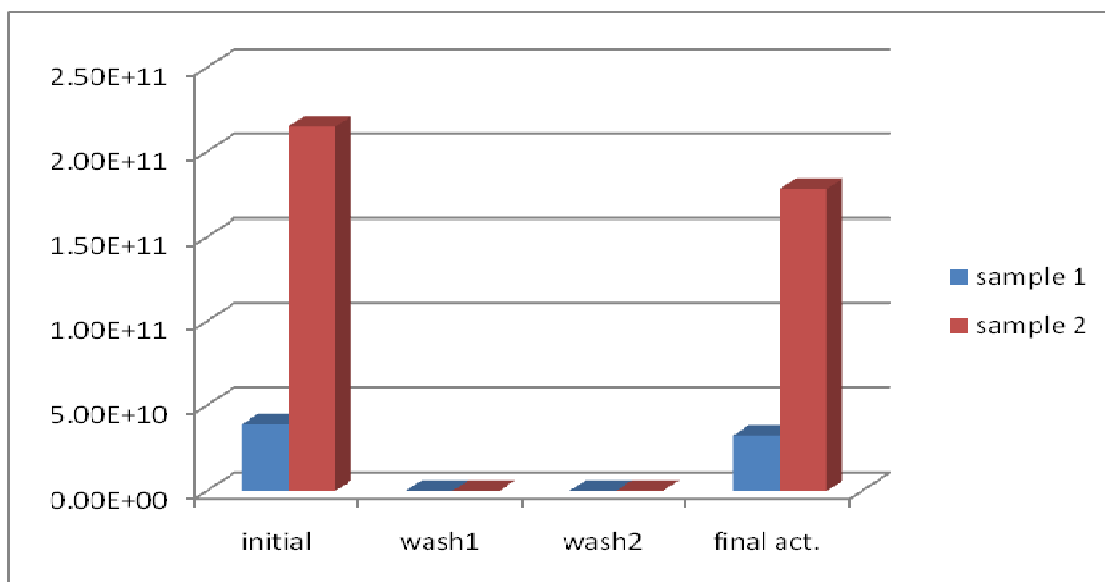

## CHAPTER 6 Conclusion

This work aimed to establish whether the Sr-Spec resin can be used at KNPS as a method of analysing for  $^{90}\text{Sr}$  shown that  $^{90}\text{Sr}$  analysis can be done much quicker making use of the Sr-spec resin, as compared to the traditional fuming nitric acid method, with its many precipitation steps which many times lead to the loss of analyte.

This considerable reduction in time addresses the issue of an accident situation, where rapid results are needed for proper decision-making. The Sr-spec resin has also shown excellent separation of Sr from Y, since only Sr is retained on the resin, and the Y is effectively eluted from the column. This method, making use of the Sr-spec resin can be used for both effluent samples at KNPS, as well as for Environmental samples. The Radiochemistry laboratory is equipped with the necessary equipment, and an advantage is that either the LSC or the alpha/beta proportional counter can be used for this analysis, with no additional time required for either counter. The method of analysis is similar, the only difference being that for the proportional counter the sample is collected as a precipitate, and on the LSC it is in liquid form. Fig.28 and Fig.29 shows the difference in MDA obtained between the methods. The Sr-Spec method gives a better MDA, since a bigger volume of sample is used, which is more preferable for the purposes of KNPS.

The LSC method is preferred, since it allows the researcher to obtain a spectrum of the count, and discrimination between beta counts can be visualised, hence certainty is given whether all interferences have been removed. The shortcoming currently with the LSC method is the higher strength of source that will be required, to be able to do the calibration, and also to be able to prepare the required amount of standards for the calibration.

The safety aspect of this method is also an important consideration, since no fuming nitric acid is used, as compared to the traditional method. Throughout the Sr-spec method various concentrations of nitric acid are used, which makes this method safer for analysts in laboratories to use.

### Recommendations

Eichrom Industries continues its tradition of being a "time-saver" by introducing the Vacuum Box System, (VBS), and extraction cartridge lines. By employing vacuum in already advanced separation methods, analysis time can easily be halved over the traditional gravity flow columns. The system yields the same consistently high yields for actinides and strontium as with conventional columns. The chromatography is also improved since the columns use the smaller 'S' grade resin. Another advantage of the cartridge design is the ability to stack two columns together for tandem separations. This system allows for simultaneous analysis of a few samples at a time, without the analyst having to prepare columns. The standard size for the VBS is a 2 mL column, which can be applied for liquid effluent samples, since these

samples will not exceed the capacity of the column. For environmental samples, bigger columns can be prepared, more particularly for soil samples. I recommend the purchase of a vacuum box system, as shown in Fig.32.

**Fig.32. Vacuum Box System**



Another recommendation is to procure a high activity  $^{90}\text{Sr}$  standardised solution for calibration of the LSC. Reference sets are traditionally only available for  $^3\text{H}$  and  $^{14}\text{C}$ . If quench calibrations need to be performed for isotopes other than  $^3\text{H}$  and  $^{14}\text{C}$ , then the quenched standards need to be prepared by the researcher. High activity standards, in the region of 180 000 – 200 000 DPM, are required, and allows for much quicker efficiency calibrations. For the LSC calibration in this work, only 5 standards could be prepared, with very low DPM's, in the region of 4000 DPM, and as a result standards counted for a much longer time period. Only 5 standards could be prepared due to a limited amount of standardised  $^{90}\text{Sr}$  source.

In order to save money, chromatography columns can be regenerated and used again, which will save on costs since the resin is quite expensive and can only be obtained through Eichrom Industries in France.

## CHAPTER 7 REFERENCES

- 1) Basic Safety Principles for Nuclear Power Plants, 75 – INSAG – 3, Rev.1
- 2) K. Breitenager, A. Vesley, M. Djuricic, R. Steininger, 2008, Searching for Sr-, Am, Pu isotopes in contaminated soils; Advances in Liquid Scintillation Spectrometry, University of Arizona, LSC.
- 3) A. Vesley, H. Trombitas, H. Lindawer, 2009, Determination of Beta emitters in materials from research reactor decommissioning, Nuclear Engineering Seibersdorf.
- 4) Radiation, People and the Environment, 1996 IAEA, Radiation Protection and Safety Radiation Sources (Safety Fundamentals), Safety Series No.20, IAEA, Vienna,
- 5) The Principles of Radioactive Waste Management, 1995, Safety Series No 111, IAEA, Vienna.
- 6) International Commission on Radiological Protection, 1985, Principles of Monitoring for the Radiation Protection of the Population, Publication 43, Pergamon Press, Oxford and New York.
- 7) Regulatory Control of Radioactive Discharges to the Environment, 2000, IAEA Safety Standards Series No: WS-G-2.3, Vienna.
- 8) [www.epa.gov/radiation/radionuclides/strontium](http://www.epa.gov/radiation/radionuclides/strontium)
- 9) H. Dahlgaard, 1994, J. Environ. Radioact, 25 (37).
- 10) A. Aarkrog, H. Dahlgaard, S.P. Nielsen, 1999 Sci. Total Environ. 238 (143).
- 11) V.N. Egorov, P.P. Povinec, G.G. Polikarpov, N.A. Stokozov, S.R. Gulin, L.G. Kulebakina, I. Osvatn, 1999, J. Environ. Radioact.43, 137.
- 13) Basic Safety Principles for Nuclear power Plants, 75 – INSAG – 3 Rev.1.
- 14) N. Vadja, A. Ghods-Esphahani, P.R. Danesi, Determination of radiostrontium in soil using a crown ether, 1992, Journal of Radioanalytical and Nuclear Chemistry, 162 (2).
- 15) N. Vadja, A. Ghods-Esphahani, P.R. Danesi, 1992, Determination of radiostrontium in soil using a crown ether, Journal of Radioanalytical and Nuclear Chemistry, 162 (2).
- 16) E. Philip Horwitz, Renaldo Chiarizia, Mark L. Dietz, 1992, A novel strontium

selective extraction chromatographic resin, *Solvent Extraction and Ion Exchange*, 10(2).

**17)** N. Vadja, A. Ghods-Esphahani, P.R. Danesi, 1992, Determination of radiostrontium in soil using a crown ether, *Journal of Radioanalytical and Nuclear Chemistry*, 162 (2).

**18)** H. Willard, E. Goodspeed, 1936, Separations of Strontium, Barium and Lead from Calcium and other metals, *Industrial and Engineering Chemistry*.

**19)** B.R. Harvey, R.D. Ibbett, M.B. Lovett, K.J Williams, 1989, Analytical procedures for the determination of strontium radionuclides in environmental materials, *Aquatic Environment Protection*.

**19a)** *J. Radioanal. and Nucl. Chem.* 1990, Vol. 138, No 2, 207-218.

**20)** K. Dorfnor, 1972, *Ion Exchangers: Properties and Applications*, Arbor Science Publisher.

**21)** J. Korkisch, 1969, Modern methods for the separation of rare metals, *Sci Tech Connect*.

**22)** J. Korkisch, 1989, *Handbook of Ion Exchange resins, Their Applicability to Inorganic Analytical Chemistry*, Vol 6. CRC Press.

**23)** O. Samuelson, 1963, *Ion Exchange Separations in Analytical Chemistry*, *Soil Science* 96 (5).

**24)** J. Korkisch, 1969, Modern methods for separation of rare metals, *Sci Tech Connect*.

**25)** Q. Chen, A. Aarkrog, S.P. Nielsen, H. Dahlggaard, H. Nies, Y. Yu, K. Mandrup, 1993, Determination of plutonium in environmental samples by controlled valence in anion exchange. *Journal of Radioanalytical and Nuclear Chemistry, Articles*, 172 (281-288).

**26)** K.M Wong, 1971, Radiochemical determination of plutonium in sea water sediments and marine organisms. *Analytica Chimica*, 56 (355-364).

**27)** J.J La Rosa, E.L Cooper, A. Ghods –Esphahani, V. Jansta, M. Makarewics, S. Shawky, N. Vadja, 1992. Radiochemical methods used by IAEA's Laboratories at Seibersdorf for the determination of Sr-90, Ce-144 and Pu radionuclides in environmental samples collected for the international Chernobyl Project, *Journal of Environmental Radioactivity*, 17(183-209).

- 28)** H. Michel, J. Gasp no, G. Barcifunel, J. Dalmasso, G. Radissons, G. Sharavavov, 1999, Radioanalytical determination of actinides and fission products in Belarus soils, *Talanta*, 48 (821-825).
- 29)** J.W. Mietelski, J. La Rosa, A. Ghods, 1999,  $^{90}\text{Sr}$ ,  $^{240}\text{Pu}$ ,  $^{238}\text{Pu}$  and  $^{241}\text{Am}$  in some samples of mushrooms and forest soils from Poland. *Journal of Radioanalytical and Nuclear Chemistry, Articles*, 170 (243-258).
- 30)** M.P.R. Montero, A.M Sanchez, M.T.C Vazquez, J.L.G Murillo, 2000, Analysis of Plutonium in soils samples, *Applied Radiation and Isotopes*, 53 (259-264).
- 31)** A. Noureddine, B. Baggoura, J.J. La Rosa, N. Vadj, 1997, Gamma and alpha emitting radionuclides in some Algerian soil samples. *Applied Radiation and Isotopes*, 48 (1145-1148).
- 32)** E. Holm, R. Fukai, 1997, Determination of americium and curium by using ion-exchange in nitric acid – methanol medium for environmental samples. *Talanta*, 23 (853-855).
- 33)** I.A Lebedev, B.F Myasoedov, L.I. Guseva, 1974, Use of alcoholic solutions for the isolation and purification of americium and curium with anion-exchangers, *Journal of Radioanalytical Chemistry*, 21 (627-642).
- 34)** E. Holm, S. Ballestra, 1989, Methods for radiochemical analysis of Pu, Am and Cu. Measurement of radionuclides in food and the environment: A guidebook. IAEA, Vienna.
- 35)** H. Michel, J. Gaspano, G. Barcifunel, J. Dalmasso, G. Ardisson, G. Sharavavov, 1999, Radioanalytical determination of actinides and fission products in Belarus soils, *Talanta*, 48 (821-825).
- 36)** J.W. Mietelski, J. La Rosa, A. Ghods, 1993,  $^{90}\text{Sr}$ ,  $^{240}\text{Pu}$ ,  $^{238}\text{Pu}$  and  $^{241}\text{Am}$ , in some samples of mushrooms and forest soils from Poland. *Journal of Radioanalytical and Nuclear Chemistry, Articles*, 170 (243-258).
- 37)** N. Dacheux, J. Aupiais, 1997, Determination of uranium, plutonium, thorium, curium and americium ultratraces by photon electron rejecting alpha liquid scintillation. *Analytical Chemistry*, 69 (2275-2282).
- 38)** P.E. Warwick, I.W. Croudace, R. Carpenter, 1996, Review of analytical techniques for the determination of  $^{241}\text{Am}$  in soils and sediments. *Applied Radiation and Isotopes*, 47 (627-642).
- 39)** S. Ballestra, R. Fukai, 1983, An improved radiochemical procedure for low-level measurement of Am in environmental materials. *Talanta*, 30 (45-48).

- 40)** G.E. Persson, S. Svantesson, S. Wingefors, J.O Liljenzin, 1984, Hot Test of TALSPEAK procedure for the separation of actinides and lanthanides using recirculating DTPA –lactic acid solution ion, Solvent extraction and ion exchange, (89-113).
- 41)** E. Holm, S. Ballestra, R. Fukai, 1979, A method for ion-exchange separation of low levels of Am in environmental materials, Talanta, 26 (791-794).
- 42)** H. Rameback, M. Skalberg, 1998, Separation of Np, Pu, Am and Cu from U with di- (2-ethylhexyl)-phosphoric acid (HDEHP) for radiometric and ICP–MS analysis. Journal of Radioanalytical and Nuclear Chemistry, 235 (229-233).
- 43)** H. Rameback, M. Skalberg, 1999, A separation procedure for the analysis of  $^{90}\text{Sr}$ ,  $^{154}\text{Eu}$  and the actinides  $^{237}\text{Np}$ ,  $^{239}\text{Pu}$ ,  $^{241}\text{Am}$  and  $^{244}\text{Cm}$ , Journal of Radioanalytical and Nuclear Chemistry, 240(2), (661-663).
- 45)** P.A. Bertrand, G.R Choppin, 1982, Separation of actinides in different oxidation states by solvent extraction, Radiochimica Acta, 31 (135-137).
- 46)** F.L Moore, W.D Fairman, J.G. Ganchoff, J.G. Surak, 1959, Selective liquid-liquid extraction of iron with 2-thenoyl-trifluoroacetone-xylene, Analytical Chemistry, 31(7), (1148-1151).
- 47)** F.L. Moore, J.E. Hudgens, 1957, Separation and determination of Pu by liquid – liquid extraction. Analytical Chemistry, 29(12) (176 –1770).
- 48)** S. Sierkierski, B. Kotlinska, 1959, Separation of Zr and Nb mixtures by the method of reversed phased partition chromatography.
- 49)** T.Braun, G. Ghersini, 1975, Extraction Chromatography, Elsevier Scientific Publishing Company.
- 50)** J. L. Cortina, A. Warshawsky, 1997, Developments in solid-liquid extraction by solvent-impregnated resins, Ion-exchange and solvent extraction, 13 (195-293).
- 51)** C. Testa, 1961, Chromatography of some cations by means of paper treated with liquid anion exchanger. Journal of Chromatography, 5(3) (236).
- 52)** G. Jia, C. Testa, D. Desideri, F. Guerra, C. Roselli, 1998, Sequential separation and determination of Pu,  $^{241}\text{Am}$  and  $^{90}\text{Sr}$  in soils and sediments, Journal of Radioanalytical and Nuclear Chemistry, 230 (1-2), (21-27)

- 53)** G. Jia, D. Desideri, F. Guerra, M.A. Meli, C. Testa, 1997, Determination of Pu and Am in moss and lichen samples, *Journal of Radioanalytical and Nuclear Chemistry*, 220(1) (15-19).
- 54)** G.Jia, C. Testa, D. Desideri, M.A. Meli, 1989, Extraction chromatography method for the determination of  $^{239}\text{Pu}$ ,  $^{240}\text{Pu}$  and  $^{238}\text{Pu}$  in soils with high natural radioactivity, *Analytica Chimica Acta*, 220 (103-110).
- 55)** G.Jia, C. Testa, D. Desideri, M.A. Meli, 1989, Simultaneous determination of Pu and Am in soils by extraction chromatography, *Journal of Radioanalytical and Nuclear Chemistry*, 133: 227-236.
- 56)** G. Jia, D. Desideri, F. Guerra, M.A. Meli, C.Tesla, 1997, Concentration and vertical distribution of Pu and Am in Italian mosses and lichen, *Journal of Radioanalytical and Nuclear Chemistry*, 222 (1-2).
- 57)** C. Testa, D. Desideri, M.A. Meli, C. Roselli, Extraction chromatography in radioecology. *Radioactivity and Radiochemistry*, 2 (4): 46-55. (**year not supplied in Literature**)
- 58)** C.Testa, D. Desideri, L. Staccioli, S. Bazzarri, 1987, Applications of column reversed-phase partition chromatography for the determination of actinides in biological and environmental samples. *Inorganic Chimica Acta*, 140 (267 – 270).
- 59)** C.Testa, D. Desideri, M.A. Meli, C. Roselli, 1995, New radio-chemical procedures for environmental actinide measurements and data quality control, *Journal of Radioanalytical and Nuclear Chemistry*, Articles, 194 (1): 141-149.
- 60)** C.Testa, D. Desideri, M.A Meli, C. Roselli, G. Queirazza, S. Bazzarri, 1993, Radioanalytical procedures for the separation and, determination of alpha, beta and x-emitters in environmental samples of a nuclear power plant before decommissioning. *The Science of the Total Environment*, 130-131, (403 – 417).
- 61)** E.P. Horwitz, M.L. Dietz, D.E. Fisher, 1991, Separation and preconcentration of Sr- from biological environmental and nuclear waste samples by extraction chromatography using a crown ether. *Analytical Chemistry*, 63 (5): 522 – 525.



**Fig.21 Gamma Source Certificate**

C-268/L



**Eckert & Ziegler**  
Isotope Products

24937 Avenue Tibbitts  
Valencia, California 91355

Tel 661•309•1010  
Fax 661•257•8303

**CERTIFICATE OF CALIBRATION  
MULTINUCLIDE STANDARD SOLUTION**

Customer: ECKERT & ZIEGLER NUCLITEC GMBH Source No.: 1827-10-3  
P.O. No.: P703988 Reference Date: 1-Aug-15 12:00 PST  
Catalog No.: 7601 Contained Radioactivity: 10.04 µCi 371.5 kBq

**Physical Description:**

- A. Mass of solution: 5.15281 grams in 5 mL flame-sealed ampoule
- B. Chemical form: Multinuclide in 2M HCl
- C. Carrier content: See attached sheet
- D. Density: 1.033 g/mL @ 20°C

Gamma-Ray Energy (keV)	Nuclide	Half-life	Branching Ratio (%)	Conc. (nCi/g)	Gammas per second per gram	Total Uncert.
60	Am-241	432.17 ± 0.66 years	36.0	57.45	765.2	3.0 %
88	Cd-109	462.6 ± 0.7 days	3.63	805.3	1082	3.1 %
122	Co-57	271.79 ± 0.09 days	85.6	27.95	885.2	3.1 %
166	Ce-139	137.640 ± 0.023 days	79.9	37.17	1099	3.1 %
279	Hg-203	46.595 ± 0.013 days	81.5	114.8	3462	3.0 %
392	Sn-113	115.09 ± 0.04 days	64.9	154.5	3710	3.0 %
514	Sr-85	64.849 ± 0.004 days	98.4	179.2	6524	3.0 %
662	Cs-137	30.17 ± 0.16 years	85.1	127.0	3999	3.0 %
898	Y-88	106.630 ± 0.025 days	94.0	291.0	10120	3.0 %
1173	Co-60	5.272 ± 0.001 years	99.86	154.5	5708	3.0 %
1333	Co-60	5.272 ± 0.001 years	99.98	154.5	5715	3.0 %
1836	Y-88	106.630 ± 0.025 days	99.4	291.0	10700	3.0 %

**Method of Calibration:**

This source was prepared from weighed aliquots of solutions whose concentrations in µCi/g were determined by gamma spectrometry.

**Notes:**

- See reverse side for leak test(s) performed on this source.
- EZIP participates in a NIST measurement assurance program to establish and maintain implicit traceability for a number of nuclides, based on the blind assay (and later NIST certification) of Standard Reference Materials (as in NRC Regulatory Guide 4.15).
- Nuclear data was taken from IAEA-TECDOC-619, 1991.
- Overall uncertainty is calculated at the 99% confidence level.
- This source has a working life of 1 year.
- EZN Item Code: 7601ML-370KBQ.

*Daniel James Van Dalsen*  
Quality Control

17-Jun-15  
Date

EZIP Ref. No.: 1827-10

ISO 9001 CERTIFIED

Medical Imaging Laboratory  
24937 Avenue Tibbitts Valencia, California 91355

Industrial Gauging Laboratory  
1800 North Keystone Street Burbank, California 91504

Fig. 22 Energy Calibration Curve

RC4G11

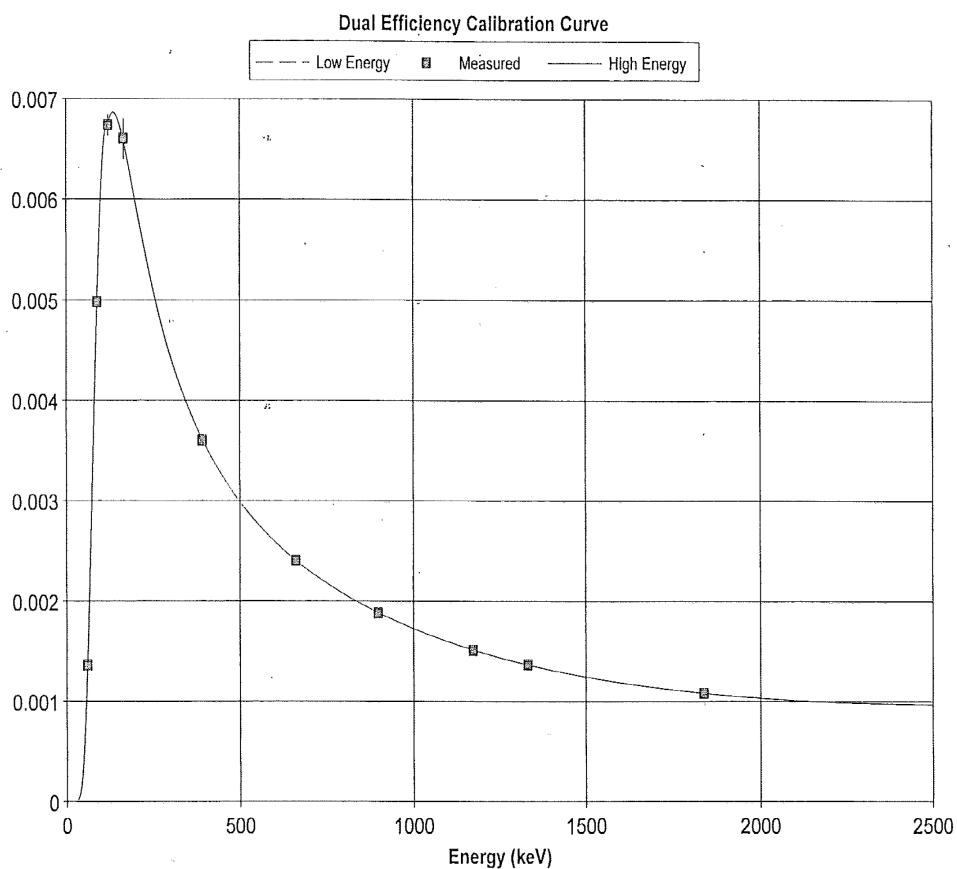

Datasource: C:\GENIE2K\CAMFILES\15064317.CNF

$$\ln(\text{Eff}) = -8.118e+001 + 3.188e+001*\ln(E) - 3.334e+000*\ln(E)^2$$

$$\ln(\text{Eff}) = -5.104e+002 + 4.041e+002*\ln(E) - 1.283e+002*\ln(E)^2 + 2.029e+001*\ln(E)^3$$

$$- 1.599e+000*\ln(E)^4 + 5.029e-002*\ln(E)^5$$

## Fig.23 Efficiency Calibration Report

Efficiency Calibration Report

2015/11/09 03:04:46 PM Page 1

\*\*\*\*\*  
\*\*\*\*\* EFFICIENCY CALIBRATION REPORT \*\*\*\*\*  
\*\*\*\*\*

Detector Name: RC4  
Sample Title: E-11/14

Geometry Description: 1L Polybottle  
Efficiency Calibration Performed on: 2015/11/09 02:59:05 PM  
by:  
Geometry Type Used: DUAL

### Efficiency Triplets =====

Energy	Efficiency	Error
59.54	1.36E-003	3.75E-005
88.03	4.98E-003	6.14E-005
122.06	6.74E-003	1.08E-004
165.86	6.60E-003	2.01E-004
391.70	3.60E-003	6.17E-005
661.65	2.40E-003	9.14E-006
898.02	1.88E-003	2.59E-005
1173.22	1.51E-003	5.92E-006
1332.49	1.36E-003	8.30E-006
1836.01	1.08E-003	9.92E-006

### DUAL Efficiency Calibration Equation =====

Crossover Point -----> 122.06

Low Equation Terms --> Offset: -81.179  
Slope: 31.875  
Quadratic: -3.334  
Cubic: 0.000  
4th Order: 0.000  
5th Order: 0.000

High Equation Terms -> Offset: -510.441  
Slope: 404.065  
Quadratic: -128.348  
Cubic: 20.291  
4th Order: -1.599  
5th Order: 0.050  
6th Order: 0.000  
7th Order: 0.000  
8th Order: 0.000  
9th Order: 0.000

Fig.24 Efficiency Calibration Report

### SOURCE 2013/C-252L

Source date: 1/08/2013 14:00

	Energy (keV)	Calculated	Measured	% Diff
Co-57	122.06	1.06E+08	1.02E+08	-3.3
Co-60	1173.24	5.73E+08	5.74E+08	0.1
Co-60B	1332.5	5.73E+08	5.76E+08	0.5
Y-88	898.04	1.07E+09	1.06E+09	-1.3
Y-88B	1836.06	1.07E+09	1.09E+09	1.5
Cd-109	88.03	3.03E+09	3.09E+09	2.0
Sn-113	391.7	5.64E+08	5.57E+08	-1.2
Cs-137	661.66	4.59E+08	4.61E+08	0.4
Ce-139	165.86	1.41E+08	1.40E+08	-0.7
Am-241	59.54	2.09E+08	2.20E+08	5.3

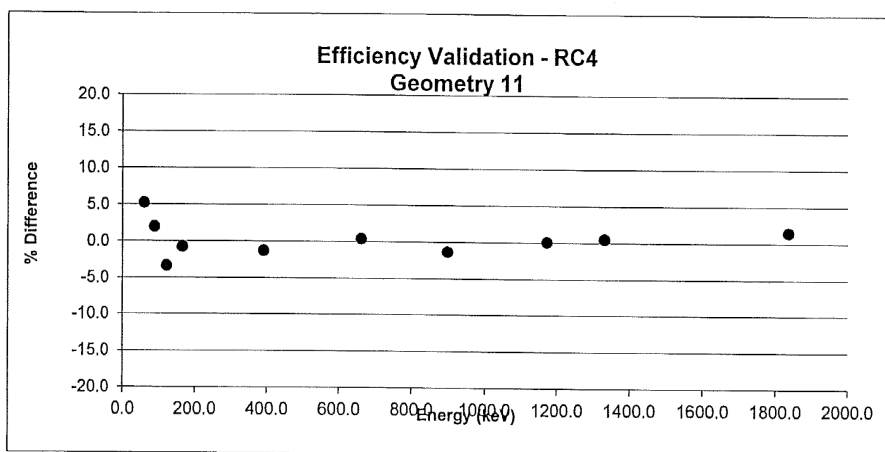



Date Counted: 2015/06/18

Report No: 15064318

Reviewed by: G Visser

Signature:

Fig.25 Efficiency Calibration Record

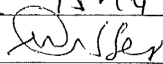
	<b>GAMMA SPECTROMETRY EFFICIENCY CALIBRATION RECORD</b>		Reference No.: KFC-CH-032	
			Revision: 0	Page: 1 OF 1
			Associated Procedure: KWC-RC-CAL-012	
IDENTIFICATION: DETECTOR/GEOMETRY				
Detector No.	FOUR			
Geometry No.	11 (Eleven)			
Geometry Description	1e PolyBottle			
NOTE: An Efficiency Calibration may NOT be performed if a valid Energy Calibration has not been performed on this detector!				
Energy Calibration performed and valid?		YES NO		
EFFICIENCY CALIBRATION				Par.
Source No. used for the Efficiency Calibration	C-264/L		7.7.1	
Original Spectrum file number (e.g. 05015111) for Efficiency Calibration	15064317		7.7.1	
Source Certificate file name (on the PC) used for the calibration	C264/L.G.11.CTR		7.7.10	
Geometry Calibration file saved as (e.g. RC5G10)	RC4G11		7.7.23	
Open the Geometry Calibration file (e.g. RC5G10) and check in Sample Info that the spectrum file number corresponds to the Original Spectrum file number above. If not, STOP!	YES NO		7.7.25 – 7.7.27	
Date and Time of 'Efficiency Calibration Performed on:' correct on the printout?	YES NO		7.7.34	
EFFICIENCY VALIDATION				Par.
Source No. used for the Efficiency Validation	C-252/11		7.8.1	
Original Spectrum file number (e.g. 05015112) for Efficiency Validation	15064318		7.8.1	
Validation results within QC Limits?	YES NO		7.8.2 – 7.8.3	
LLD CHECK				
Does this geometry require LLD qualification? [If NO, cross out the remaining requirements in this section]		YES NO		
Original Spectrum file number (e.g. 05015113) used for LLD check		15064393		
LLD requirements met?		YES NO		
GEOMETRY RECORDS				
Are all blocks completed and requirements met?		YES NO		
Printouts Attached:	Efficiency curve	YES NO	7.7.18	
	Efficiency report	YES NO	7.7.34	
	Validation report	YES NO	7.8.1	
	LLD report	YES NO		
Technical Review Section Head	Name / Signature	K. Dittake 		
Date and Time	Geometry placed in service	2015.11.11 @ 15h47		
Technician	Name / Signature	G. Visser 		

**Fig.26 Beta Standard Certificate of Calibration**



**Eckert & Ziegler**  
Isotope Products

24937 Avenue Tibbitts  
Valencia, California 91355  
Tel 661-309-1010  
Fax 661-257-8303

*C-250/L*

**CERTIFICATE OF CALIBRATION  
BETA STANDARD SOLUTION**

Radionuclide:	Sr-90	Customer:	ECKERT & ZIEGLER NUCLITEC GMBH
Half-life:	28.5 ± 0.2 years	P.O. No.:	P700436
Catalog No.:	7090	Reference Date:	1-May-13 12:00 PST
Source No.:	1653-96	Contained Radioactivity:	0.1053 µCi 3.896 kBq (Sr-90 only)

**Physical Description:**

- A. Mass of solution: 4.99566 g in 5 mL flame-sealed ampoule
- B. Chemical form: SrCl<sub>2</sub> in 0.1M HCl
- C. Carrier content: (10 µg Sr + 50 µg Y)/mL of solution
- D. Density: 0.9996 g/mL @ 20°C

**Radioimpurities:**

None detected (Y-90 daughter in equilibrium)

Radionuclide Concentration: 0.02108 µCi/g, 0.7800 kBq/g

**Method of Calibration:**

This source was prepared from a weighed aliquot of solution whose activity in µCi/g was determined using a liquid scintillation counter.

**Uncertainty of Measurement:**

- A. Type A (random) uncertainty: ± 0.2 %
- B. Type B (systematic) uncertainty: ± 3.0 %
- C. Uncertainty in aliquot weighing: ± 0.7 %
- D. Total uncertainty at the 99% confidence level: ± 3.1 %

**Notes:**

- See reverse side for leak test(s) performed on this source.
- EZIP participates in a NIST measurement assurance program to establish and maintain implicit traceability for a number of nuclides, based on the blind assay (and later NIST certification) of Standard Reference Materials (as in NRC Regulatory Guide 4.15).
- Nuclear data was taken from NCRP Report No. 58, 1985.
- This solution has a working life of 5 years.

*Daniel James Van Dolen*  
Quality Control

3-Apr-13  
Date

EZIP Ref. No.: 1653-96

ISO 9001 CERTIFIED

Medical Imaging Laboratory  
24937 Avenue Tibbitts Valencia, California 91355

Industrial Gauging Laboratory  
1800 North Keystone Street Burbank, California 91504

Fig 27 iMatic Efficiency Calibration Report

<b>Radiochemistry</b>		<b>Changes requiring this sheet to be unprotected MUST be submitted to a formal technical review by the Head of Radiochemistry, or her/his designate.</b>			
<b>Sr Analysis - Calibration</b>					
<i>Appendix 1</i>					
<b>Certified Source</b>					
Original Specific Activity	Bq/ml	35.650		T1/2 (Sr-90) [years]	28.80
Source Reference Date		2013/02/01		T1/2 (Sr-90) [days]	10518.91
Calibration Date		2013/03/10		Decay [Days]	37.00
Activity - day of calibration	Bq/ml	35.563			
WARNING A source volume of 1ml was previously assumed - corrected here for future changes to mass b					
Source Volume	ml	0.50			
<b>Yield and Sr Efficiency Calculation</b>					
<b>Measured Activity of Standards</b>					
Beta Results	Repl1	STD 1	STD 2	STD 3	STD 4
		13.225	15.42	14.29	12.4
	2	14.17	14.29	13.3	14
	3	13.465	14.355	14.55	12.7
	4	13.815	13.2	14.75	12.4
Activity Source [Bq] MEASURED		13.6688	14.3163	14.2225	12.8750
<b>Theoretical Activity of Standards</b>					
		STD 1	STD 2	STD 3	STD 4
Mass of empty planchet	m1	6.7378	6.7212	6.7356	6.7346
Mass of planchet+Source	m2	6.7506	6.7355	6.7512	6.7488
Mass Source (g)	m3=m2-m1	0.0128	0.0143	0.0156	0.0142
Activity Source [Bq] CALCed		17.7816		0.0000	0.0000
<b>% Chemical Yield</b>		76.87	80.51	79.98	72.41
	Mean StdD	77.44	3.72250771		
<b>Total Counting Background</b>					
<i>Background determined counting planchet with filter paper, extraction chemicals, etc.</i>					
Background Counting Time		60	min		
Gross Background Counts		59	cts		
Background Count Rate		0.983333333 cpm			
<b>Activity of Standards</b>					
Counting Time for Standards		2	min		
<b>Measured Gross Counts</b>					
	Cts	STD 1	STD 2	STD 3	STD 4
		482	416	450	392
		450	452	419	401
		458	450	458	449
		470	485	464	391
AVERAGE Gross Counts	Cts	465.00	450.75	447.75	408.25
Net Counts	CPS	4.00	3.45	3.73	3.25
		3.73	3.75	3.48	3.33
		3.80	3.73	3.80	3.73
		3.90	4.03	3.85	3.24
Net Counts (from Avg above)	CPS	3.86	3.74	3.71	3.39
Measured Specific Activity	Bq/ml	8.00	6.90	7.47	6.50
... calculated with no correction for DetEff, i.e. DetEff and ChemYield are		7.47	7.50	6.95	6.65
		7.60	7.47	7.60	7.45
		7.80	8.05	7.70	6.48
Average Specific Activity	(a)	7.72	7.48	7.43	6.77
Specific Activity (from Avg above)		7.72	7.48	7.43	6.77
<b>Theoretical Activity of Standards</b>					
		STD 1	STD 2	STD 3	STD 4
Calc. Specific Activity	Bq/ml (b)	27.34	28.63	28.45	25.75
<i>(corrected for Chemical Yield)</i>					
Strontium Efficiency	= (a)/(b)	28.229	26.123	26.120	26.297
Strontium Efficiency Average %		26.692			

Fig.28 – Sr-90 Analysis Report using Fuming Nitric acid method

<i>Sr-90 Analysis -All Instruments</i>				Rev. 3
<b>Specific Activity Report</b>				
<b>Sr-90</b>				
Rev. 1				
Instrument Channel	<b>All Instruments</b>			
Date of Calibration	2015/07/23			
Sample ID	1 CEX Q/C			
Sample Date Time	2015/07/01 00:00			

Parameters	Instr. Ref.	Values	Units	BG Count Time	60	Min
BgdCountRate	Bgd cpm	0.6	CPM			
ChannelEff%	ChEff.	18.017	%			
UnitConversion	Coef	1.6667E+04				
	Unit	Bq/m3				
Volume	Volume	1.20E+02	m <sup>3</sup>			
Gross	Raw	46	Counts			
CountTime	Time	60.00	Min			
CountRate CPM	Rate	7.67E-01	CPM			
<b>Specific Activity</b>	<b>Act</b>	<b>1.28E+02</b>	<b>Bq/m<sup>3</sup></b>	<b>Calc.LLD =</b>	<b>3.59E+02</b>	<b>Bq/m<sup>3</sup></b>

Required LLD  
Liquid Effluent Releases  
KER, SEK Tanks & B/P,  
SEC  
< 1.85E+03 Bq/m<sup>3</sup>

Specific Activity < MDA of 3.587E+02 Bq/m<sup>3</sup>

Comments

**Verifications**

Correct Channel No on Instrument

Calibration Date Valid

Specific Activity = Act (Instr.Printout)

LLD requirement met (Calc. LLD < Required LLD)

Analyst CW

Signature

Results entered on LIMS

CW

2015-08-01

Analyst                      Signature                      Date

Fig.29 Sr-90 Analysis Report Using Sr- Spec Resin

<b>Sr-90 Analysis -All Instruments</b>				Rev. 3
<b>Specific Activity Report</b>				
<b>Sr-90</b>				
Rev. 1				
Instrument Channel	All Instruments			
Date of Calibration	2015/07/23			
Sample ID	2 CEX Q/C			
Sample Date Time	2015/07/01 00:00			

Parameters	Instr. Ref.	Values	Units	BG Count Time	60	Min
BgdCountRate	Bgd cpm	0.6	CPM			
ChannelEff%	ChEff.	18.017	%			
UnitConversion	Coef	1.6667E+04				
	Unit	Bq/m3				
Volume	Volume	5.00E+02	ml			
Gross CountTime	Raw Time	58	Counts			
		60.00	Min			
CountRate CPM	Rate	9.67E-01	CPM			
<b>Specific Activity</b>	<b>Act</b>	<b>6.78E+01</b>	<b>Bq/m<sup>3</sup></b>	<b>Calc.LLD =</b>	<b>8.61E+01</b>	<b>Bq/m<sup>3</sup></b>

Specific Activity < MDA of 8.608E+01 Bq/m<sup>3</sup>

Comments

**Verifications**

Correct Channel No on Instrument	<input checked="" type="checkbox"/>
Calibration Date Valid	<input checked="" type="checkbox"/>
Specific Activity = Act (Instr.Printout)	<input checked="" type="checkbox"/>
LLD requirement met (Calc. LLD < Required LLD)	<input checked="" type="checkbox"/>

Analyst	GV		
Signature			

Results entered on LIMS	<input checked="" type="checkbox"/>	<input checked="" type="checkbox"/>	<input checked="" type="checkbox"/>	<input checked="" type="checkbox"/>	
	GV		2015-08-05	Analyst	Signature
			Date		

