

AN INVESTIGATION ON THE SUITABILITY OF LAYER MANUFACTURING  
METHODS FOR RAPID TOOLING DEVELOPMENT  
IN INVESTMENT CASTING OF LIGHT METAL ALLOYS

BRENT S. DEEZ

CAPE PENINSULA  
UNIVERSITY OF TECHNOLOGY  
Library and Information Services  
DATE REC'D. TUE 621. 984 DEG

CAPE PENINSULA  
UNIVERSITY OF TECHNOLOGY



20122169

CAPE PENINSULA UNIVERSITY OF TECHNOLOGY  
LIBRARY AND INFORMATION SERVICES  
BELLVILLE CAMPUS

TEL: (021) 959-6210

FAX: (021) 959-6109

Renewals may be made telephonically.

This book must be returned on/before the last date shown.

Please note that fines are levied on overdue books

THE 621.984 DEE  
green



**An Investigation on the Suitability of Layer Manufacturing Methods  
for Rapid Tooling Development in Investment Casting of Light Metal  
Alloys**

**by**

**BRENT STEVEN DEEZ**

**Thesis submitted in fulfilment of the requirements for the degree**

**Magister Technology: Mechanical Engineering**

**in the Faculty of Engineering**

**at the CAPE PENINSULA UNIVERSITY OF TECHNOLOGY**

**Supervisor:** Professor Graeme John Oliver

**Bellville**

December 2010

**CPUT Copyright Information**

The dissertation/thesis may not be published either in part (in scholarly, scientific or technical journals), or as a whole (as a monograph), unless permission has been obtained from the university

## DECLARATION

I, Brent Steven Deez, declare that the contents of this thesis represent my own unaided work, and that the thesis has not previously been submitted for academic examination towards any qualification. Furthermore, it represents my own opinions and not necessarily those of the Cape Peninsula University of Technology.

Signed  Date 06/06/2011

## ABSTRACT

The research presented in this report focuses on Investment Casting capabilities for light metal alloys in South Africa and forms part of the Advanced Manufacturing Technology Strategy's (AMTS): Light Weight Metals flagship programme.

The research is centred on the suitability of rapid prototyping (RP)/layer manufacturing (LM) methods to produce patterns for the investment casting of aluminium (Al), magnesium (Mg) and titanium (Ti) alloys, together known as Rapid Investment Casting. Three core RP technologies are investigated namely: Three Dimensional Printing – Drop-on-Bed from Z-corporation, Three Dimensional Printing – Drop-on-Drop from ThermoJet - 3D Systems and Selective Laser Sintering from EOS.

Various RP/LM processes are discussed in detail and highlight the technologies selected in this study. A standard benchmark part, adapted from the European project framework FP6, designed and utilised in similar studies is used as the basis for the research.

The Investment Casting process is discussed fully and compared to the Rapid Investment Casting, listing both the advantages and disadvantages of the above mentioned methods.

In addition a special study has been conducted on investment casting of large components using layer manufactured patterns. This study not only helped to establish and validate the shrinkage value calculated for the aluminium castings but also showed substantial capability lacks in SA foundries to handle this type of components, which are by definition most often of high added value.

A full statistical analysis is carried out with regards to dimensional and form accuracy as well as the surface finish of the patterns and replication to castings is discussed. The Material property's specification for Al, Mg and Titanium alloys with a particular emphasis on shrinking values are also investigated.

The analysis further confirmed that the LS patterns produced the best castings in terms of dimensional and geometric accuracy also from both Ti and Mg alloys. The polystyrene as pattern material shows best

compatibility with the face coats for both types of alloys. After evaluation it can also be concluded that the Alumide wax patterns produce better Mg and Ti castings than those from the Polyamide wax pattern. On the contrary the Polyamide wax patterns produced better aluminium castings than the wax patterns made from the Alumide die.

Initial experiments proved the unsuitability of the laser ablation process for integration in the titanium component fabrication process chain. More promising results can be obtained by chemical milling. Unfortunately, due to problems at the CSIR chemical milling equipment no experimental research could be conducted. The Hot Isostatic Process required as a post process for titanium castings is also discussed.

The process economics are elaborated on and the report concludes with recommendations for research avenues for relevant future work.

## ACKNOWLEDGEMENTS

I wish to thank the following people and organizations for the tremendous support during the undertaking of this research.

- Professor D. Dimitrov- Head of the Laboratory for Rapid Product Development Labs (RPDL) at the University of Stellenbosch
- Phillip Hugó a colleague and friend- Laboratory for Rapid Product Development at the University of Stellenbosch.
- Pierre Rossouw, Senior Researcher at the CSIR, Materials Science and Manufacturing,
- Professor Graeme Oliver- Cape Peninsula University of Technology
- To My Family Tanya, Tatum, Ursula, Lauren and my late father, Reynold, for all the understanding and support during difficult times.

Thank you all.

## TABLE OF CONTENTS

DECLARATION .....	II
ABSTRACT.....	III
ACKNOWLEDGEMENTS .....	V
TABLE OF CONTENTS.....	VI
LIST OF FIGURES .....	X
LIST OF TABLES.....	XII
LIST OF ABBREVIATIONS .....	XIII
1. INTRODUCTION.....	1
1.1. STATEMENT OF RESEARCH PROBLEM .....	2
1.2. BACKGROUND TO THE RESEARCH PROBLEM .....	3
1.2.1. INVESTMENT CASTING OVERVIEW .....	3
1.2.2. CONVENTIONAL INVESTMENT CASTING .....	4
1.2.3. PROCESS CHAIN FOR RAPID PATTERN MAKING .....	6
2. RELATED LITERATURE .....	9
2.1. LAYER MANUFACTURING PROCESSES .....	9
2.2. LM PROCESSES FOR RAPID PATTERN MAKING AND RAPID TOOLING.....	11
2.2.1. STEREO LITHOGRAPHY .....	11
2.2.2. SELECTIVE LASER SINTERING .....	12
2.2.3. LASER ENGINEERED NET SHAPING .....	14
2.2.4. DIRECT METAL DEPOSITION .....	15
2.2.5. ELECTRON BEAM MELTING .....	16
2.2.6. SELECTIVE LASER MELTING.....	17
2.2.7. LAMINATED OBJECT MANUFACTURING.....	18
2.2.8. THREE DIMENSIONAL PRINTING TECHNIQUES (3DP).....	19

2.2.8.1.DROP-ON-DROP DEPOSITION (DOD)- THERMAL PHASE CHANGE INKJETS .....	20
2.2.8.2.PHOTOPOLYMER PHASE CHANGE INKJETS (THERMOJET MODELER™) .....	22
2.2.8.3.DROP-ON-POWDER DEPOSITION- 3D PRINTING .....	23
2.2.8.4.CONTINUOUS DEPOSITION- FUSED DEPOSITION MODELLING.....	25
2.2.9.SUMMARY OF LAYER MANUFACTURING PROCESSES .....	26
2.3. INVESTMENT CASTING .....	29
2.3.1.ADVANTAGES OF CONVENTIONAL INVESTMENT CASTING.....	29
2.3.2.DISADVANTAGES OF CONVENTIONAL INVESTMENT CASTING–COMPARATIVELY.....	30
2.3.3.DEFECTS OCCURRING DURING CONVENTIONAL INVESTMENT CASTING .....	30
2.3.4.RAPID INVESTMENT CASTING OVERVIEW .....	31
2.3.5.ADVANTAGES OF RAPID INVESTMENT CASTING .....	31
2.3.6.DISADVANTAGES OF RAPID INVESTMENT CASTING.....	32
3. LAYER MANUFACTURED INVESTMENT CASTING PATTERNS .....	34
3.1. DESIGN FOR MANUFACTURE.....	34
3.2. RAPID PROTOTYPE LIMITATIONS.....	36
3.2.1. PATTERNS REQUIREMENTS FOR IC .....	36
3.2.1.1. ACCURACY .....	36
3.2.1.2. ACCURACY OF MEASUREMENT .....	37
3.2.1.3. LOW ASH CONTENT .....	37
3.2.1.4. THERMAL EXPANSION.....	38
3.2.1.5. REMOVAL OF RESIDUAL ASH .....	39
3.2.1.6. BUILD ORIENTATION .....	40
3.2.2. COMPONENTS EXCEEDING WORK ENVELOPE OF LM MACHINES.....	41
4. RESEARCH APPROACH AND METHODOLOGY .....	42
4.1. DIMENSIONAL AND GEOMETRIC ACCURACY: TERMS AND DESCRIPTIVE STATISTICS .....	42
4.1.1. DESCRIPTIVE STATISTICS.....	42
4.2. SURFACE QUALITY .....	48

4.3.	COMPONENT SELECTION FOR RESEARCH .....	48
4.4.	EVALUATION METHODOLOGY .....	54
4.5.	INVESTMENT CASTING FACILITY – COUNCIL FOR SCIENTIFIC AND INDUSTRIAL RESEARCH (CSIR) , .....	57
5.	CASE STUDY- HYDRODYNAMIC TORQUE CONVERTOR IMPELLER .....	59
5.1.	PATTERN CREATION AND PREPARATION .....	60
5.2.	RAPID PATTERN - EVALUATION RESULTS AND DISCUSSION .....	62
5.2.1.	STATISTICAL OBSERVATIONS .....	62
5.3.	CASTING - EVALUATION RESULTS AND DISCUSSION .....	67
5.3.1.	STATISTICAL OBSERVATIONS .....	67
5.3.2.	SHRINKAGE .....	68
5.3.3.	RESULTS DISCUSSION .....	70
5.3.4.	OBSERVATIONS .....	70
5.4.	CONCLUSIONS AND RECOMMENDATIONS .....	72
6.	DISCUSSION AND ANALYSIS OF EXPERIMENTAL RESULTS.....	74
6.1.	ALUMINIUM CASTINGS .....	77
6.2.	EVALUATION AND DISCUSSION OF RESULTS - ALUMINIUM CASTINGS .....	78
6.2.1.	STATISTICAL OBSERVATIONS .....	78
6.2.2.	ALUMINIUM SHRINKAGE VALUE .....	80
6.2.3.	ANALYSIS OF THE BUILT FEATURES (ALUMINIUM CASTINGS FROM LM PATTERNS) .....	81
6.2.4.	ANALYSIS OF THE BUILT FEATURES (ALUMINIUM CASTINGS FROM DIE WAX PATTERNS) .....	83
6.2.5.	ANOVA ANALYSIS .....	85
6.3.	EVALUATION AND DISCUSSION OF RESULTS - MAGNESIUM (MG AZ91D) CASTINGS .....	87
6.3.1.	STATISTICAL OBSERVATIONS .....	88
6.3.2.	MAGNESIUM SHRINKAGE VALUE .....	89
6.3.3.	ANALYSIS OF THE BUILT FEATURES [MAGNESIUM CASTINGS FROM LM PATTERNS AND DIES] .....	90

6.3.4.ANOVA ANALYSIS.....	92
6.4. EVALUATION AND DISCUSSION OF RESULTS- TITANIUM (TI6AL4V) CASTINGS .....	93
6.4.1.STATISTICAL OBSERVATIONS .....	95
6.4.2.TITANIUM SHRINKAGE VALUE .....	97
6.4.3.ANALYSIS OF THE BUILT FEATURES (TI CASTINGS FROM LM PATTERNS AND DIES) .....	98
6.4.4.ANOVA ANALYSIS.....	100
6.4.5.TITANIUM POST PROCESSING .....	100
6.4.5.1.HOT ISOSTATIC PRESSING (HIP) .....	101
6.4.5.2.LASER ABLATION .....	102
7. PROCESS ECONOMICS .....	104
7.1. PATTERN AND DIE COSTS .....	104
7.2. INVESTMENT CASTING COST .....	105
8. CONCLUSIONS AND RECOMMENDATIONS.....	106
11.REFERENCES.....	110
APPENDICES	
Appendix A Features Measured - Drawings	116
Appendix B Aluminium Castings - Features CMM Data	120
Appendix C Aluminium Castings - Statistical CMM Raw Data (3D-Tol Data)	135
Appendix D Aluminium Castings - Histograms (3D-Tol Data)	169
Appendix E Magnesium Castings - Features CMM Data	172
Appendix F Magnesium Castings - Statistical CMM Raw Data (3D-Tol Data)	193
Appendix G Magnesium Castings - Histograms (3D-Tol Data)	246
Appendix H Titanium Castings - Features CMM Data	249
Appendix I Titanium Castings - Statistical CMM Raw Data (3D-Tol Data)	271
Appendix J Titanium Castings - Histograms (3D-Tol Data)	324
Appendix K Pattern - Statistical CMM Raw Data (3D-Tol Data)	327
Appendix L Casting - Statistical CMM Raw Data (3D-Tol Data)	338

## LIST OF FIGURES

- Figure 1.1 Investment Casting Focus Areas
- Figure 1.2 Conventional Investment Casting
- Figure 1.3 Investment Casting Process Chains
- Figure 2.1 General RP Process Chain
- Figure 2.2 Rapid Prototyping and Tooling Processes
- Figure 2.3 Stereolithography Principle Scheme
- Figure 2.4 Selective Laser Sintering - Principle Scheme
- Figure 2.5 Laser Engineered Net Shaping - Principle Scheme
- Figure 2.6 Direct Metal Depositions - Principle Scheme
- Figure 2.6 Direct Metal Depositions - Principle Scheme
- Figure 2.7 Electron Beam Melting - Principle Scheme
- Figure 2.8 Selective Laser Melting - Principle Scheme
- Figure 2.9 Laminated object Manufacturing - Principle Scheme
- Figure 2.10 Solidscape's Single-Jet Inkjet - Principle Scheme
- Figure 2.11 Multi-Jet Modelling™ - Principle Scheme
- Figure 2.12 Jetted Photopolymer System - Principle Scheme
- Figure 2.13 Three Dimensional Printing - Principle Scheme
- Figure 2.14 Fused Deposition Modelling - Principle Scheme
- Figure 3.1 Effects of build orientation
- Figure 4.1 EC FP6 Benchmark Part
- Figure 4.2 Polyamide and Alumide Dies
- Figure 4.3 Counter gravity Vacuum Furnace
- Figure 4.4 Modified Vacuum furnaces.
- Figure 5.1 Hydrodynamic Torque Convertor Impellor
- Figure 5.2 Split Pattern
- Figure 5.3 Wax Infiltration of Pattern
- Figure 5.4 Jig Used for Assembly of Two Halves
- Figure 5.5 Assemblies and Finishing of Pattern
- Figure 5.6 Polystyrene Pattern
- Figure 5.7 Geometrical and Dimensional Features measured
- Figure 5.8 Pump 440-01– Aluminium Casting

Figure 5.9	Porosity shown in Casting
Figure 5.10	Crack formation
Figure 5.11	Porosity at gates
Figure 6.1	3DP- Zcorp (A), LS- EOS (B) and ThermoJet (C)
Figure 6.2	Polyamide Cavity
Figure 6.3	Polyamide Cavity
Figure 6.4	Wax injected Patterns from LM Dies
Figure 6.5	Re-enforced Polyamide and Alumide Dies
Figure 6.6	Aluminium Castings from LM Patterns -3DP- Zcorp (A), LS- EOS (B) and ThermoJet (C)
Figure 6.7	Aluminium Castings from Alumide and Polyamide Die Wax Patterns
Figure 6.8	Magnesium Castings from LM Patterns -3DP- Zcorp (A), LS- EOS (B) and ThermoJet (C)
Figure 6.9	Magnesium Castings from Polyamide die
Figure 6.10	Equipment failure
Figure 6.11	LS Ti casting
Figure 6.12	Latest Titanium Castings produced from 3DP and LS patterns
Figure 6.13	Ti castings from a Polyamide (A) and Alumide (B) Dies
Figure 6.14	Diameter 18mm Rod cross-section- Red arrows indicating Alpha case layer
Figure 6.15	Laser Ablation Titanium Test Piece
Figure 6.16	vacuum heat treatment facilities

## LIST OF TABLES

Table 2.1	Deposition Processes and Corresponding Technologies
Table 2.2	LM Processes Applicability to Investment Casting
Table 6.1	Geometric Tolerance Descriptions
Table 6.2	Feature Definitions
Table 6.3	Features and Tolerance Measurements
Table 6.4	Dimensional Accuracy Index Tolerances
Table 7.1	Descriptive Statistics – Pattern (Pump 440-01)
Table 7.2	Dimensional Observations – Pattern (Pump 440-01)
Table 7.3	Patterns Surface Roughness
Table 7.4	Descriptive Statistics – Casting (Pump 440-01)
Table 7.5	Dimensional Observations – Casting (Pump 440-01)
Table 8.1	LM process used for experimentation
Table 8.2	Aluminium Castings Statistics
Table 8.3	Shrinkage Value Calculation for Aluminium Castings
Table 8.4	DAI of Aluminium Castings
Table 8.5	Single factor ANOVA Results @ 95% Confidence (Aluminium Castings from LM Patterns)
Table 8.6	Single factor ANOVA Results @ 95% Confidence (Aluminium Castings from Die Patterns)
Table 8.7	Mg Castings Statistics
Table 8.8	Shrinkage Value for Mg Castings
Table 8.9	DAI of Magnesium Castings
Table 8.10	Single factor ANOVA Results @ 95% Confidence
Table 8.11	Ti Castings Statistics
Table 8.12	Shrinkage Value for Ti Castings
Table 8.13	DAI of Titanium Castings
Table 8.14	Single factor ANOVA Results @ 95% Confidence
Table 8.15	Ablated Titanium Surface Roughness's
Table 9.1	Process Economics – LM Patterns
Table 9.2	Casting prices

## List of Abbreviations

3DP	Three Dimensional Printing
Al	Aluminium
AMTS	Advanced Manufacturing Technology Strategy
CAD	Computer Aided Design
CIC	Conventional Investment Casting
CMM	Coordinate Measuring Machine
CSIR	Council for Scientific and Industrial Research
DFM	Design for Manufacture
DMD	Direct Metal Deposition
DMLS	Direct Metal Laser Sintering
DOB	Drop on Base
DOD	Drop on Drop
EBM	Electron Beam Melting
FDM	Fuse Deposition Modelling
HIP	Hot Isostatic Pressing
IC	Investment Casting
LENS	Laser Engineered Net Shaping
LM	Layer Manufacturing
LOM	Layer Object Manufacturing
LS	Laser Sintering
Mg	Magnesium
RIC	Rapid Investment Casting
RP	Rapid Prototyping
RPT	Rapid Prototyping Tooling
RT	Rapid Tooling
SLA	Stereolithography
SLM	Selective Laser Melting
SLS	Selective Laser Sintering
Ti	Titanium

## 1. INTRODUCTION

The report presented focuses on Investment Casting capabilities for light metal alloys in South Africa and forms part of the Advanced Manufacturing Technology Strategy's (AMTS): Light Weight Metals flagship programme. A study undertaken by South Africa's Department of Science and Technology and AMTS, (2006), stated that globally this technology is still in an emerging stage in our country. Therefore an investment casting capability has to be developed nationally in order to support and enhance South Africa's industry. The diagram below, figure 1.1, illustrates the research areas forming the basis for the overall AMTS project. The main sectors involved are the automotive and aerospace industries. Worldwide focus is placed on global warming meaning that less fuel should be used and therefore the development of lighter vehicles and airplanes are needed. Light metals are to be the key focus area in order to reduce weight.

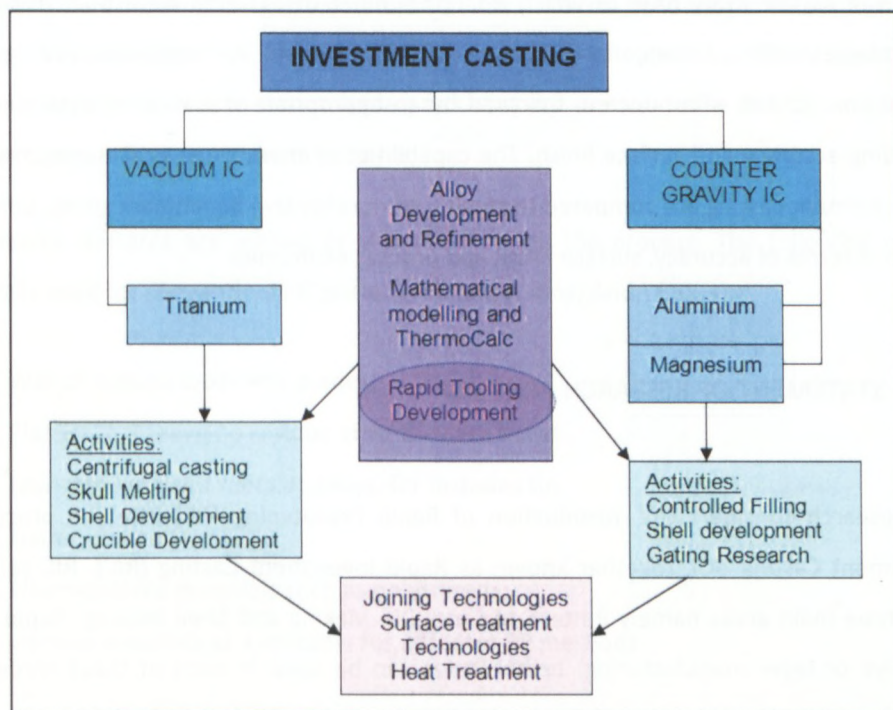

**Figure 1.1 Investment Casting Focus Areas**  
(South Africa. Dept of Science and Technology and AMTS, 2006)

The research presented in this study has been completed over the past three years and this report concludes the three year time frame. The focus of the research was to evaluate and select process chains for rapid tooling development for investment casting of light metals such as Titanium (Ti), Magnesium (Mg) and Aluminium (Al) alloys, together known as Rapid Investment Casting (RIC). RIC can be divided into three main areas namely Pattern Making, Die Making and Shell Making. The advantage of RIC is that conventional tooling is not required to create IC patterns, saving time and cost.

Conventional investment casting (CIC) always involves a tooling cost as well as a lead time to manufacture this required tooling. A comparison of the RIC method to the CIC must be done to determine the most feasible process with respect to cost, suitability of pattern material, quality and manufacturing time.

A standard benchmark part developed for similar research within the FP6 framework programme was used as the study base of which a large number of patterns were built using three core technologies 3DP- Z-Corp, LS-EOS and DOD-ThermoJet. A comprehensive measurement programme (CMM) is conducted, followed by an appropriate statistical analysis and evaluation regarding accuracy and surface finish. The capabilities of these three prototyping methodologies for investment casting are compared through a comprehensive benchmark study. Conclusions are drawn in terms of accuracy, surface finish and process economics

## 1.1. STATEMENT OF RESEARCH PROBLEM

The research considers the introduction of Rapid Prototyping (RP) into the process chain of Investment Casting (IC), together known as Rapid Investment Casting (RIC). RIC can be divided into three main areas namely Pattern Making, Die Making and Shell Making. Rapid Prototyping (additive or layer manufacturing) technologies can be used in each of these three areas with varying results. The objective of the study is to determine the best suited RP method for the IC process with an emphasis on dimensional and geometric accuracy, casting quality and the shrinkage value for Al, Mg and Ti.

## 1.2. BACKGROUND TO THE RESEARCH PROBLEM

### 1.2.1. INVESTMENT CASTING OVERVIEW

Investment casting is also known as Lost Wax Process, Precision Casting, Precision Investment Casting, Lost Pattern Casting and Hot-Investment Casting. This is one of the oldest manufacturing processes and can be used to make intricate shapes with high accuracy.

The investment casting process can be divided into two distinct categories: expendable or permanent patterns. When using expendable patterns, the pattern is destroyed in the process. With permanent patterns, the pattern is manufactured from metal, plaster or wood and the dies and directly made from the patterns. With permanent patterns multiple dies are usually created instead of single dies. Multiple dies are used in order to remove the pattern from this die. In broader terms, the die is split into multiple parts and not just one core and cavity. Precision Investment Casting refers to the use of expandable patterns. Both these categories of investment casting give smooth surface finishes with good accuracy. However, accuracy is lost when using permanent patterns due to the multiple parts that are used to make the die and therefore not used as commonly as expendable patterns.

Expendable patterns are melted or vaporized during the process. The following materials are generally used for conventional IC pattern manufacturing, Anon (2003):

- Wax of various types and grades
- Plastics that leave no residue after they are burnt
- Low-melting point metallic alloys, for instance tin
- Frozen mercury
- Thermoplastic materials such as polystyrene
- Various materials as applicable for different RP methods

### 1.2.2. CONVENTIONAL INVESTMENT CASTING

The conventional investment casting (CIC) process is explained in the following steps shown in figure 1.2:

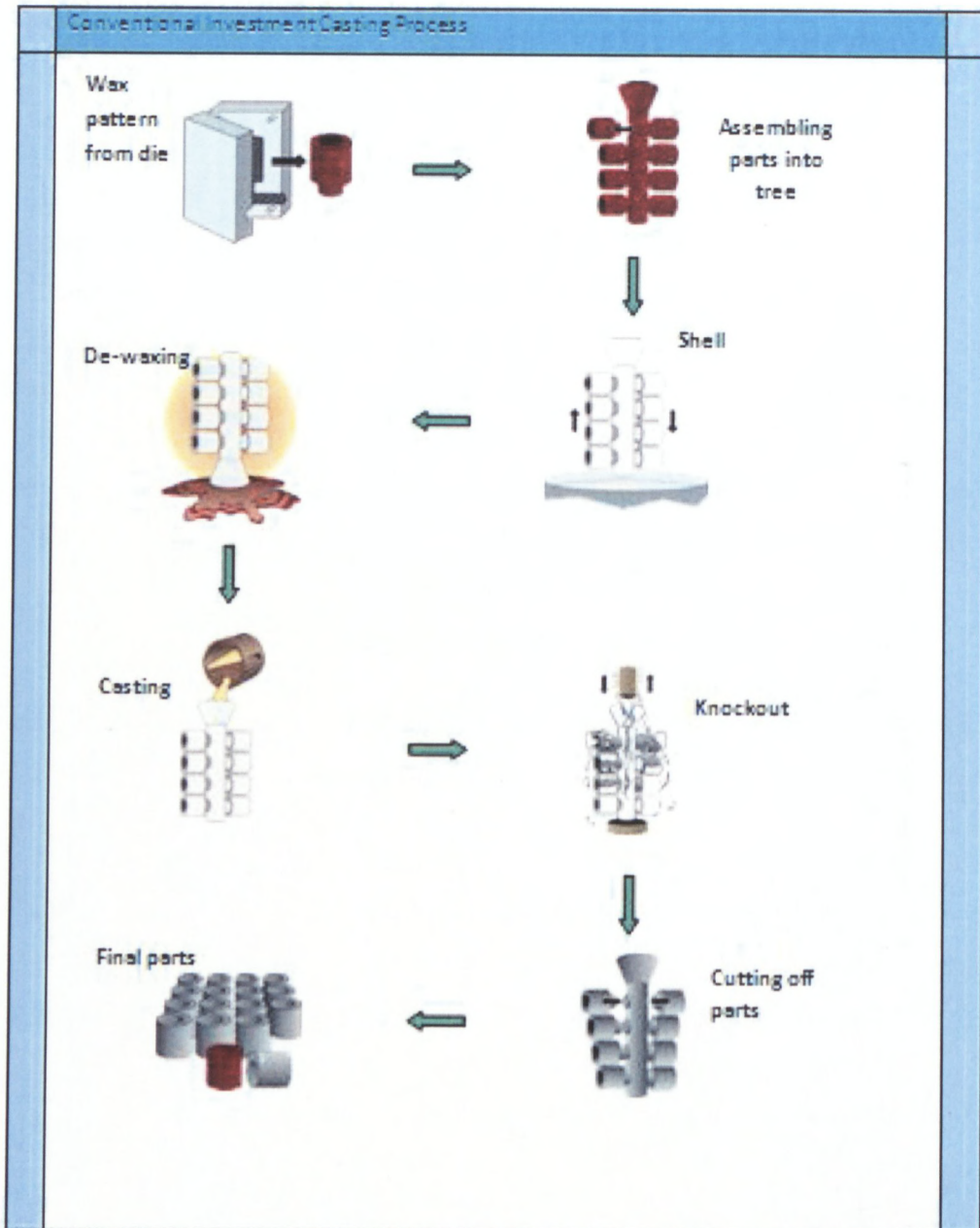

Figure 1.2 Conventional Investment Casting  
(Adapted from <http://www.kovatchcastings.com/technicalinfo.htm>)

### Pattern Making

A wax replica (pattern) of the component needed is made. Patterns are usually formed by injecting wax or polystyrene into a pre-manufactured die, usually manufactured out of metal. Dies can be simple and hand operated ranging up to fully automated multi-cavity tools. Patterns are slightly larger to allow for volumetric and metal shrinkage during the casting stage. Wax characteristics determine the quality of the finished casting. Most casters/foundries use a blend of wax, resins and filler materials; premixed by suppliers (Hugo, 2008).

### Clustering (Assembly)

Small patterns are assembled into a spray or cluster around a gating and feeding system, forming a "tree" to be cast. Feeder heads and gates are designed on the principle of directional solidification, Beeley (2001). Bigger parts are assembled singularly or in smaller groups depending on the weight and size of the component.

### Ceramic Shell Making

The wax assembly is dipped into thin refractory slurry. After draining, fine refractory grains (usually zircon) are deposited on the damp surface, forming the primary coating. The covering of the wax assembly with refractory is known as investing. Binders are usually alcohol based (ethyl silicate) or water based (silica sol), or a mixture of the two. For low temperature melts slurries are a mixture of plaster, a binder and powder silica that functions as a refractory. For high temperature melts slurries are an alumina-silicate (sillimanite), used as a refractory and silica is used as a binder. The first or primary layer is extremely important as it directly affects the parts surface finish. The dipping process is repeated until the desired shell thickness is obtained. The fine sand (stucco) acts as stressor points that help prevent cracking of the shell during casting, known as stuccoing, Rossouw, (2009).

### De-waxing

An autoclave is generally used to remove the wax from the shells thermally. Chemical processes could also be used. The wax is literally melted out, leaving only a negative impression of the part to be cast. Polystyrene patterns get vaporized. The shell is then fired to a high temperature to eliminate any residual wax and to allow chemical and physical changes in the refractories to take

place (sintering process). These changes allows for maximum strength and stability of the shells. (Hugo, 2008)

#### Casting

It is common practice in foundries to use air melting and the majority cast a wide range of ferrous and non-ferrous materials using gravity, pressure or vacuum casting. The shell is preheated to  $\pm 1000$  °C before casting to prevent it from breaking during the casting process and also to promote metal flow during filling of the shell. The ceramic shell is filled with molten metal. The parts, gates, runner and pouring cup become one solid object as the metal cools, Hugo (2008).

#### Knockout

After the metal has fully solidified and cooled to room temperature, the shell is broken off using impact, vibration, chemical dissolution or high-pressure water blasting.

#### Cut-Off

After the knockout process is complete, the feeder system is removed by either a high speed abrasive slitting wheel or a band-saw.

#### Final Castings

Gates are removed through grinding or cutting and the surface cleaned/fettled and inspected for conformity. Further operations like milling, drilling, grinding etc. are carried out if required. Most castings weigh less than 5 kg and intricate parts below 0.5 kg. Heavy castings exceeding 50 kg are also produced; in these cases the Replicast process is normally implemented and makes use of expanded polystyrene patterns, (Beeley, 2001).

### 1.2.3. PROCESS CHAIN FOR RAPID PATTERN MAKING

The conventional IC process can be summarized in the following eight steps as illustrated in the figure 1.3 below, from Cheah *et al.*, 2005. The process chain to follow is based on the CIC process chain, where certain steps are eliminated and other replaced by the related rapid prototyping technology. The figure clearly shows the time saving advantage of RIC.

Direct pattern fabrication for rapid investment casting follows the same steps as conventional investment casting, except that there is no need to manufacture a die and filling it with wax. The patterns are directly printed, grown or built with the use of additive technologies, see Cheah *et al.*, (2005). Processes include LOM, SLS, SLA, FDM, 3D-Printing in various versions such as drop-on-drop (MM2, ThermoJet) or drop-on-bed (Z-Corp) and others. The same procedure is followed for direct die fabrication except that the die has to be filled with wax to create the pattern. It still has a time saving advantage of approximately 50 % over the CIC process chain.

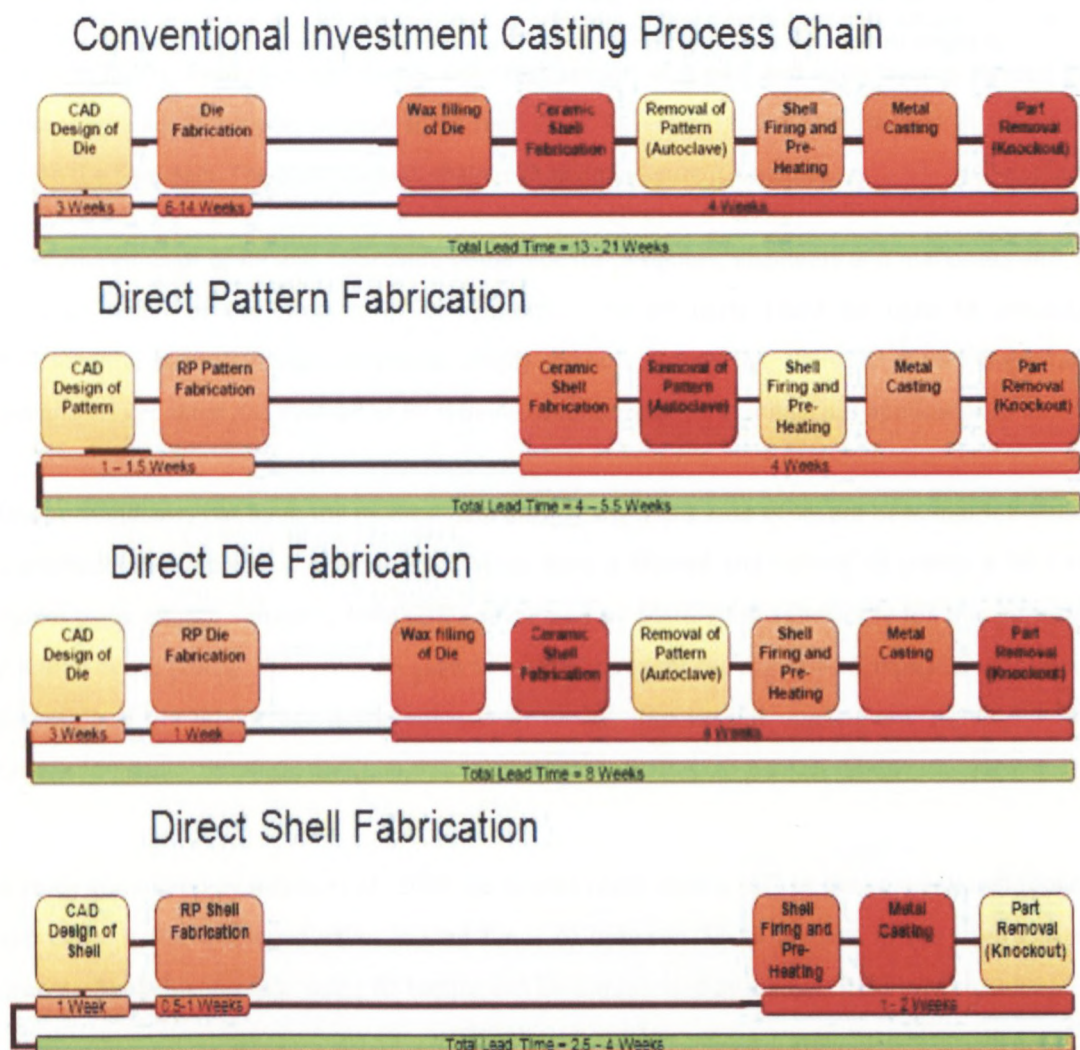

Figure 1.3 Investment Casting Process Chains  
(Adapted from Cheah *et al.*, 2005)

Using layer manufacturing processes to directly produce ceramic shells eliminates the pattern and die manufacturing steps. Even cores can be directly included in the shell.

The CIC process is used primarily when a large quantity of components is required. These could be as much as one hundred thousand and even more, where as the direct pattern fabrication is ideal for one offs.

Direct die fabrication is used when small/low volume production is needed. These are typically 5 to 15 components. This process would not be used for more as the dies lose integrity and strength through the wax injection process. The direct shell process is also ideal for one offs.

## 2. RELATED LITERATURE

### 2.1. LAYER MANUFACTURING PROCESSES

Rapid prototyping started in the late 1980s when 3D Systems Inc. introduced the first machine namely the SLA-1. Currently there are more than 44 manufacturers in the world offering different RP systems and materials to customers for various applications , Wohlers ,2007; Cheah *et al.*, 2005. Conventional fabrication involves the subtraction of materials like milling, drilling, CNC machining, laser cutting etc. RP is based on the principle of layer manufacturing where material is added in layers. Each layer represents the cross-section of a part and each layer is formed by processing a liquid, powder or solid sheet feed stock. Layers are fused together one at a time to create the final part. The basic process chain is showed in figure 2.1 below.

The initial concept of RP was to provide visual aids for designers, engineers and marketers with a physical model of the product or component. The RP parts could be used to simulate functionality, conduct design reviews or simply to show prospective clients/investors the actual design. This concept has evolved as RP is being used more often in numerous applications.

One such industry has been the medical field particularly in the case of severe head injuries where craniofacial bio-implants are required. CT-scan data is filtered and refined to create a 3D CAD model using special software, MIMICS©, developed by Materialise specifically for this purpose, P.K.Maji *et al.*, (2008). RP has been used to build IC patterns for craniofacial implants with great success and the technology is spreading even further into various applications within medical field.

A study conducted by Ingole *et al.*, 2009, compared rapid tooling (RT) to the conventional tooling approach. It showed a reduction in lead times of between 83-93 percent in the sand casting process. The advantages of using RT tooling can be summarised as follows: (Ingole *et al.*, 2009)

- Produces accurate cast iron dies, since it uses accurately produced RP patterns
- Process is economical, manufacturing of patterns do not require tooling and process planning

- Intricate cast iron dies can be easily produced, since there is no limitation for shape of the required pattern
- Dies produced are suitable for investment casting,
- Injection and blow moulding processes; and dies are suitable for materials like wax, plastics and low melting point alloy parts.

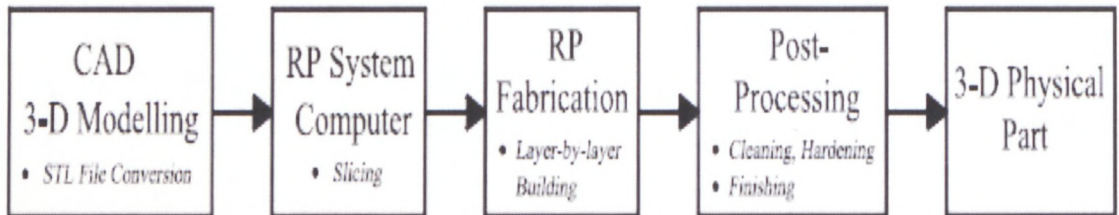
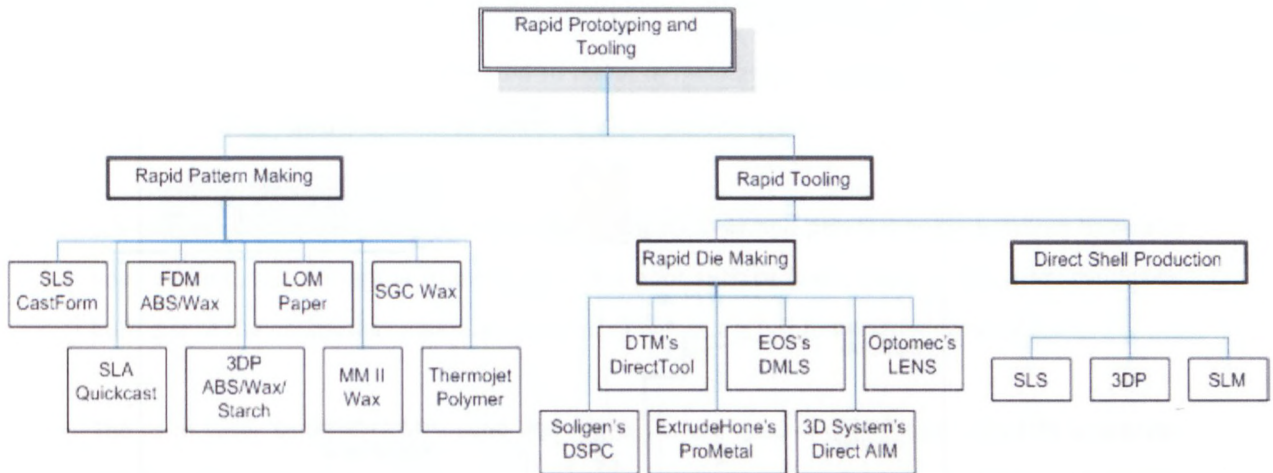

**Figure 2.1 General RP Process Chain**  
(Adapted from Cheah *et al.*, 2005)

This shows promising gains in utilising RP and has been acknowledged by various design engineers who have implemented RP into the development stage of products/components (O'Shaughnessy, 2004). Multiple designs can be investigated in parallel which would allow for the most optimised solution cost effectively.

Rapid tooling (RT) involves the use of LM technologies to manufacture tooling and tooling inserts. Levy *et al.*, 2003 conducted research in this area to develop this technology to suit production tooling requirements. The aim of this research was to produce tooling which could form thousands or even millions of parts before wearing out. Rapid Investment Casting involves the use of RP and RT techniques in the IC process where the aim is to reduce the production cycle time of IC.

## 2.2. LM PROCESSES FOR RAPID PATTERN MAKING AND RAPID TOOLING



**Figure 2.2 Rapid Prototyping and Tooling Processes**  
(Adapted from Cheah *et al.*, 2005)

The figure 2.2 above depicts typical RP and Rapid Prototype Tooling (RPT) processes.

### 2.2.1. STEREO LITHOGRAPHY

Stereolithography (SLA) works on the principle that certain liquid photopolymer resins turn solid when exposed to a specific colour of light. Ultraviolet light is most commonly used. The process is described as follows and shown in figure 2.3 below, <http://home.att.net/~castleisland/> [12 August 2006]:

- As a part grows layer by layer, a working table moves downward in a vat of the liquid resin.
- The laser is moved by a scanner system to trace the cross-section's geometry of the parts being grown.
- A knife edge is sometimes used to help with the recoating of each layer of resin, smoothing it.
- Overhangs and/or undercuts must have support structures.
- After growing, the part is elevated from the vat and excess resin is manually removed from the surfaces.

- f) Post curing is often carried out by placing the part under intense light, similar to post curing in an oven.
- g) After printing is completed the supports are cut off and the surface is fettled/ finished off.

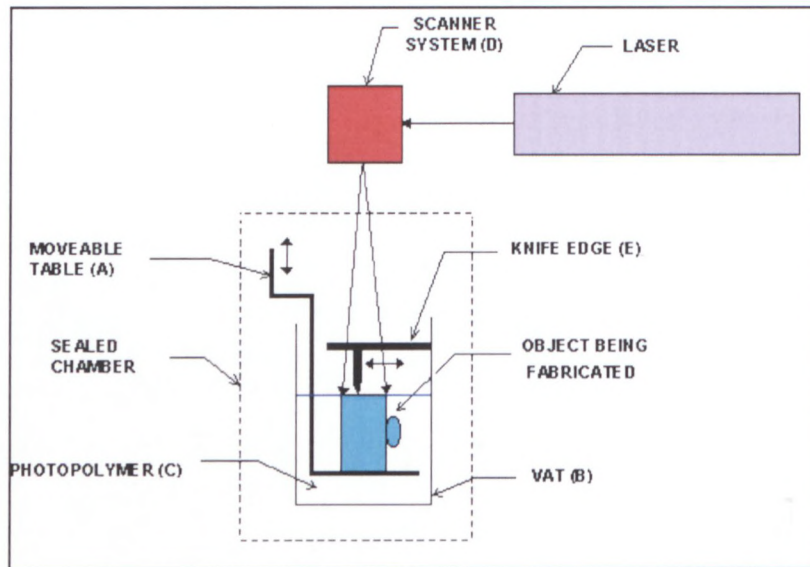

**Figure 2.3 Stereolithography Principle Scheme**  
 (Adapted from <http://home.att.net/~castleisland/>, [12 August 2006])

### 2.2.2. SELECTIVE LASER SINTERING

Selective Laser Sintering (SLS) uses a laser beam to melt a powder made from thermoplastic material, <http://home.att.net/~castleisland/>, [12 August 2006], see figure 2.4 below:

- a) The process uses two pistons. The one piston's function is to build volume where the piston incrementally moves down in a cylinder after each layer is built. The second piston contains the powder which is incrementally lifted after each added layer.
- b) The content of the powder volume is spread over the build cylinder with a roller.
- c) A scanner system is applied to guide the CO<sub>2</sub> laser to provide a concentrated infrared beam.
- d) To speed up the whole building process the building chamber is heated to just below the melting point of the powder, meaning that the powder only need to be heated slightly in order to melt.
- e) Overhangs and undercuts are supported by the tightly packed powder bed.

Parts must usually be left in the chamber to cool down before removal. This period can finish in as little as an hour or two or it can take as long as two days for large parts with thin sections. Excess powder is brushed, vacuumed and air-blown away. Parts are porous due to the sintering process and may need to be infiltrated to increase mechanical properties. According to Wohlers (2007), SLS does not have the best surface finish or density qualities.

SLS can be used to build polystyrene patterns for IC. Wax and polycarbonate patterns have also been applied, but are prone to distortions and poor surface finish. Hollow structures cannot be built due to the powder entrapment, except if openings are left for powder removal.

The term Laser Sintering (LS) is used and not SLS when used in connection with EOS processes, due to trade mark issues between 3D-Systems and EOS. The term SLS will also refer to LS relating to the specific manufacturer contextualized.

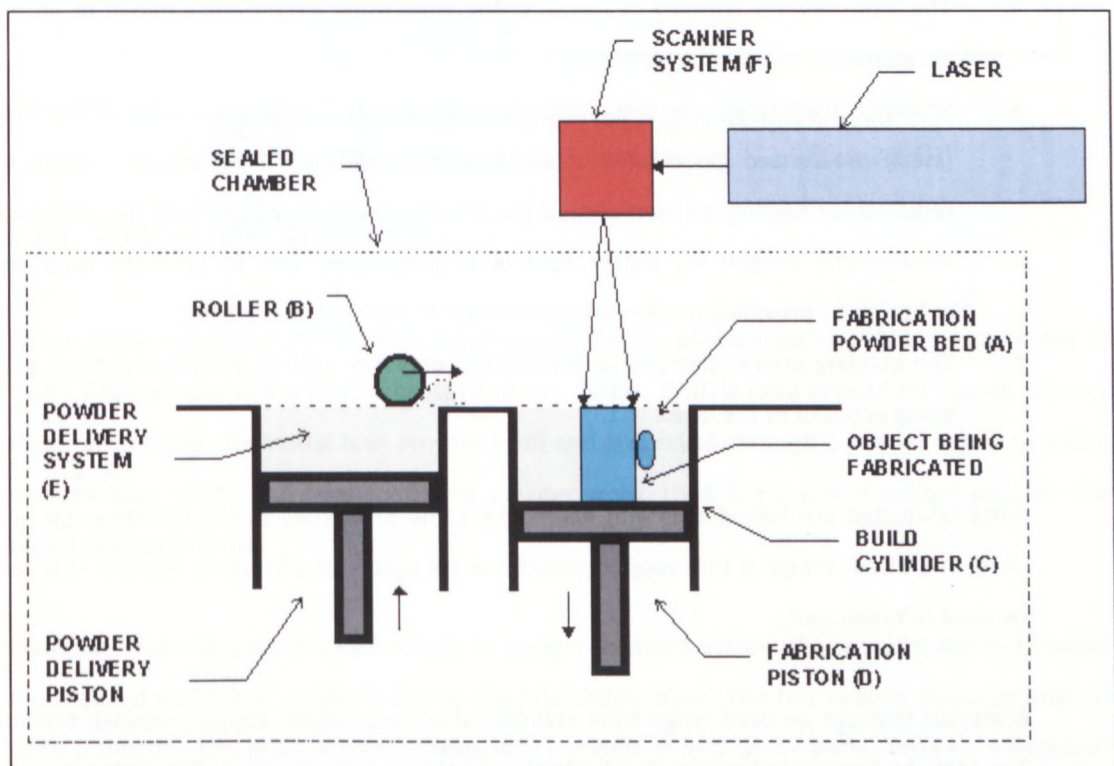

Figure 2.4 Selective Laser Sintering - Principle Scheme  
(Adapted from <http://home.att.net/~castleisland/>, [12 August 2006])

### 2.2.3. LASER ENGINEERED NET SHAPING

Laser Engineered Net Shaping (LENS) is a laser powder forming technology. The main advantage of this technology is its ability to fabricate 'fully dense metal parts' with excellent metallurgical properties (Smugeresky et al., 1997). A few variations of the process exist and are sometimes referred to as laser fusing. LENS technology is used for tooling purposes and not for pattern making in investment casting (figure 2.5).

1. A deposition head is utilized to supply the metal powder coaxially to the focus of a laser beam.
2. The laser beam normally passes through the centre of the deposition head and through one or more lenses in order to focus the beam to a certain spot.
3. The object table moves in x and y directions to fabricate each part layer. Usually the deposition head moves upward incrementally after each layer fabricated.
4. The laser beam is typically delivered to the work using a right-angle mirror or fibre optics. Other means can also be employed.
5. Gravity is used to convey and distribute metal powders around the edge of the head or a (inert) pressurized gas is utilized to carry the powder. "Even in cases where it's not required for feeding, an inert shroud gas is typically employed to shield the melt pool from atmospheric oxygen for better control of properties, and to promote layer to layer adhesion by providing better surface wetting" Boothroyd, *et al.*, 1994.
6. The building area is shielded to protect the operator against inhaling powders, gasses or being exposed to the laser.

Parts fabricated are fully-dense with nearly the same properties as the fundamental materials used. The disadvantage is that support structures are solid and difficult to remove. LENS can also be used to repair parts.

Materials that can be used range from stainless steel, aluminium, copper, inconel, titanium etc. The LENS trademark belongs to Sandia National Labs and Sandia Corp. The DMDS Direct Metal Deposition System™ (DMDS) is used by Optomec.

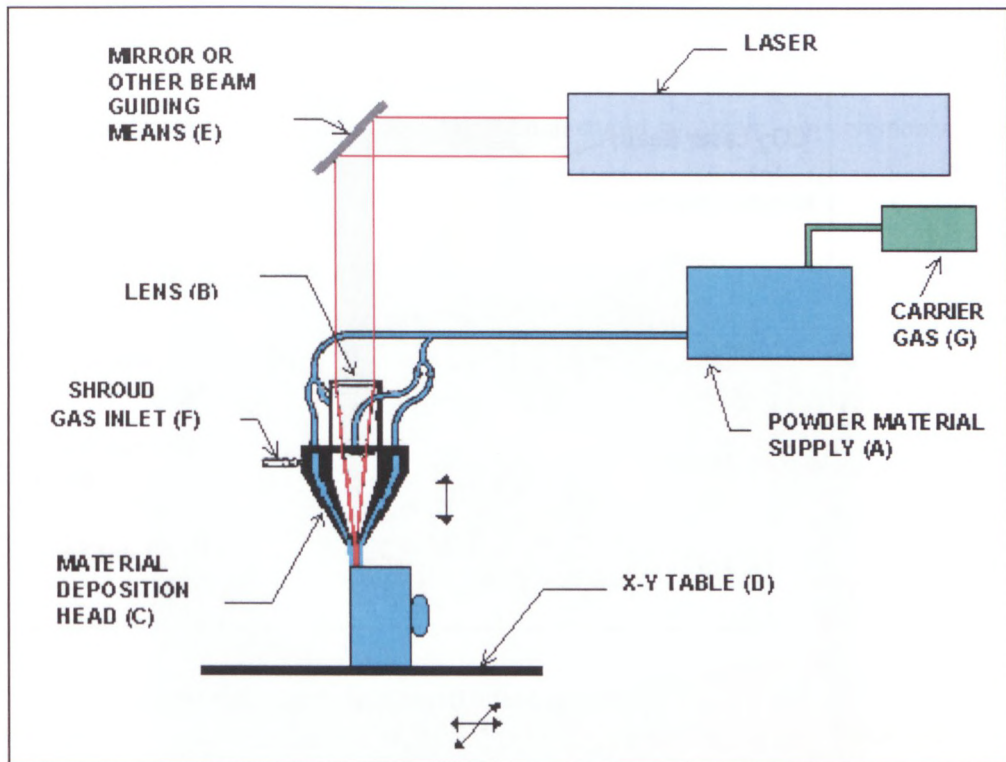
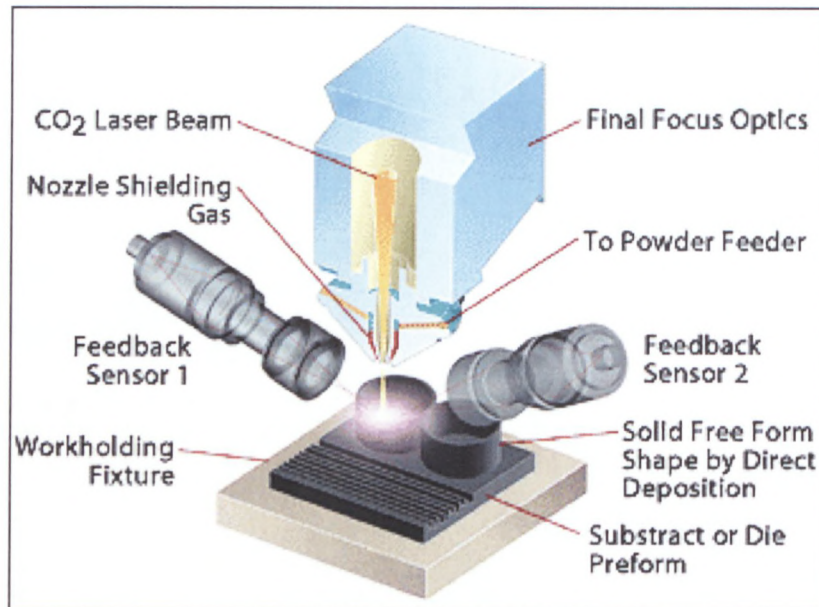

Figure 2.5 Laser Engineered Net Shaping - Principle Scheme  
 (Adapted from <http://home.att.net/~castleisland/>, [12 August 2006])

#### 2.2.4. DIRECT METAL DEPOSITION

Direct Metal Deposition (DMD) from the Precision Optical Manufacturing (POM) group shown in figure 2.6, is similar to the LENS process (Wohlers, 2007). DMD is used to produce moulds, dies or metal prototypes. The metal is in powder form and is sprayed through a coaxial nozzle to a CO<sub>2</sub> focused laser beam. The laser melts the powder which then forms a thin molten pool on the object subjected to it.

POM has revolutionized this technology by using a feedback system that ensures the quality and dimensional stability of products during the fabrication stage. The fast cooling characteristics of DMD produce a fine grain microstructure, which results in fully dense parts. Parts have excellent mechanical and metallurgical properties. POM enhances the ability of DMD to create bimetallic parts – these are parts that consist of more than one metal. Conformal cooling channels can easily be included in tooling. DMD is mostly used to create and repair dies and moulds.



**Figure 2.6 Direct Metal Depositions - Principle Scheme**

(Adapted from [http://www.pomgroup.com/tool\\_reconfiguration1.asp](http://www.pomgroup.com/tool_reconfiguration1.asp), [16 September 2009])

#### 2.2.5. ELECTRON BEAM MELTING

Electron Beam Melting (EBM) is utilized to create solid metal parts from metal powders. The powders employed have characteristics of the final material intended. The machine lays down successive layers of powdered material after which each layer is fused together by means of an electron beam, Christensen *et al.*, 2007. A computer system controls the whole process. "The electron beam's high power ensures a high rate of deposition and an even temperature distribution within the part which gives a fully melted metal with excellent mechanical and physical properties" <http://www.arcam.com/technology/faq/electron-beam-melting-ebm.aspx>, [15 September 2009]

Building commences under a vacuum environment which helps to maintain the chemical composition of the material. The vacuum environment also provides for the use of reactive materials like titanium alloys (figure 2.7). The melted material is made of a pure alloy in powder form in the final material to be fabricated. The final components produced are solid metal parts.

EBM technology employed by Arcam allows for the production of solid parts in titanium and steel, which can be machined afterwards. Parts from Arcam have been utilized for engine parts and rock drill tools with great success. EBM machines, manufactured by Arcam, are commonly used for rapid manufacturing of medical implants, aerospace and automotive products.

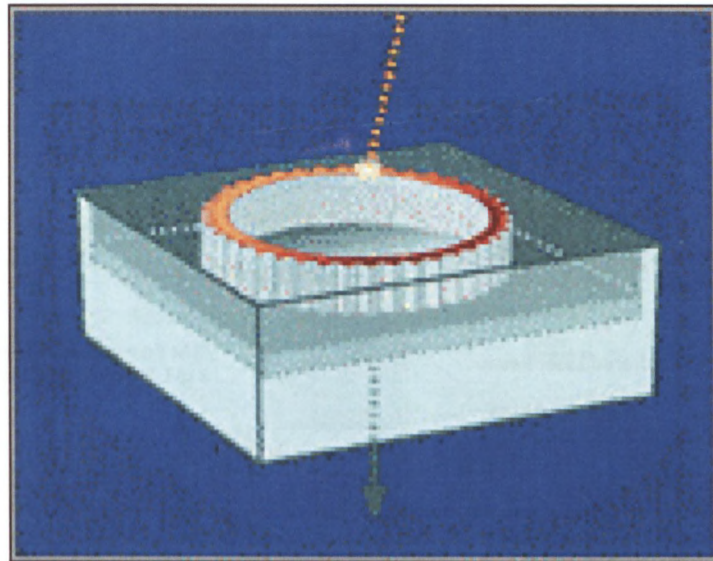

**Figure 2.7 Electron Beam Melting - Principle Scheme**

(Adapted from <http://www.arcam.se/technology/index.asp>, [15 September 2009])

#### 2.2.6. SELECTIVE LASER MELTING

SLM (Selective Laser Melting) is a new rapid tooling method that makes it possible to produce close to 100 % dense metal parts, using customary metal powders. SLM is a layer manufacturing technology that employs an intensive infrared laser beam to trace the profile of each layer, melting the metal powder without overheating or distorting the surrounding material (figure 2.8). No post processing like heat treatment or infiltration is needed but is possible if necessary. Fine details are possible for example: thin vertical walls of less than 0.1 mm thickness. Surface roughness values of 10 to 30  $\mu m$  ( $Rz$ ) are obtained directly after the production of parts or tools (<http://www.mcp-group.com/rpt/rpttslm.html>, [25 January 2008]). Parts and tooling inserts can be built from basically any type of metal or ceramic materials namely: zinc, bronze, stainless steel, tool steel, titanium, chromium-cobalt and MCP low melting point alloys. Internal undercuts and channels can be built and used as conformal cooling channels. On average 5 cm<sup>3</sup> of dense steel

per hour can be built, making this quite a high speed building process. SLM is used to build titanium medical implants as well as tooling inserts from various materials. SLM can be used to build dies and ceramic shells for investment casting purposes. MCP markets their machines under the Realizer<sup>SLS</sup> name. A similar process was developed by Concept Laser GmbH. It is marketed under the name Laser Cusing (Wohlers, 2007).

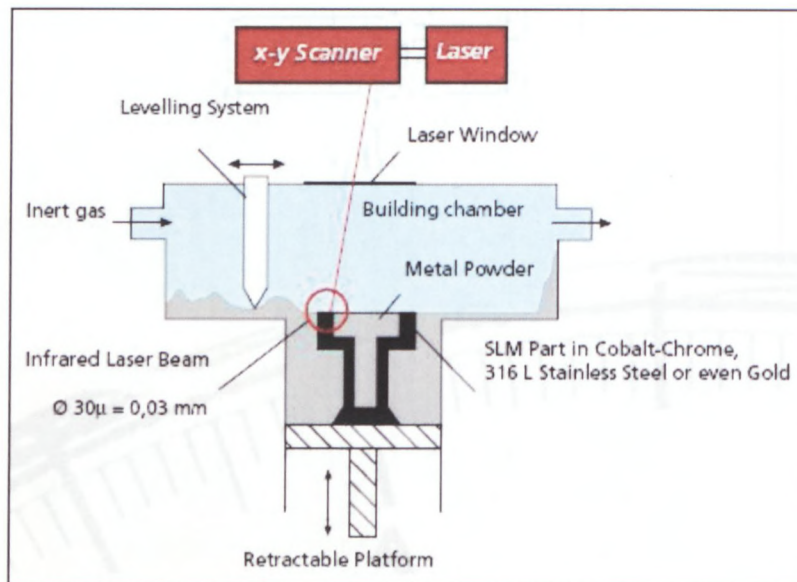

**Figure 2.8 Selective Laser Melting - Principle Scheme**

(Adapted from <http://www.mcp-group.com/rpt/rpttslm.html>, [25 January 2008])

### 2.2.7. LAMINATED OBJECT MANUFACTURING

Laminated Object Manufacturing (LOM) parts are manufactured from layers of paper (figure 2.9). A roll of paper is wound in incremental lengths at a time from a feed roll to a receiving roll (Hugo, 2008). Each time a new incremental length of paper is bonded on top of the previous layer using a heated roller which melts a plastic coating on the bottom side of the paper. Other processes of bonding are also applied, for instance by means of a solvent.

Cross section profiles are cut using a CO<sub>2</sub> laser or knife system mounted to an optics system. The excess paper supports all undercuts and overhangs. Excess paper is automatically cross hatched during each layer to help the removal of the part afterwards. The LOM process generates a lot of smoke and a chimney or a charcoal filtration system must be applied to remove smoke from a

sealed chamber. LOM does not have the best finish and accuracy, but these can be greatly improved during post processing. LOM is a registered trademark of Helisys Inc.

LOM is utilized to produce paper patterns for IC. Patterns must be coated with a layer of sealant to prevent it from swelling and delaminating due to moisture absorption. LOM patterns are cheap to produce, but sometimes lack intricacy due to difficulties in removing excess paper, Cheah *et al.*, 2005.

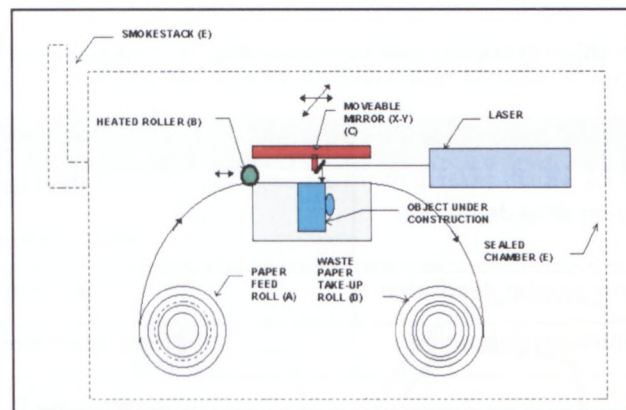

**Figure 2.9 Laminated object Manufacturing - Principle Scheme**  
(Adapted from <http://home.att.net/~castleisland/>[12 August 2006])

### 2.2.8. THREE DIMENSIONAL PRINTING TECHNIQUES (3DP)

Phase change inkjets work on the principle of squirting a building material which is in a melted or liquid state. It then cools and sets to form a solid once it gets in contact with a surface. Depending on the inkjet method, a thermal, polymerisation or physical phase change takes place.

Three dimensional printing is a development of Ink-Jet Printing technology. There are two types of Ink Jet Printing, Dimitrov *et al.*, 2007.

- Continuous Ink Jet Printing (continuous deposition) uses a stream of charged droplets and deflects those, which are to be used for printing.
- Drop-on-Demand Ink Jet Printing positions the ink jet printing head over the place where printing is to occur before depositing a droplet.

Many techniques are developed from ink jet printing technology. The printer head is the only common element which serves to shoot either drops of binder, or of liquid-to-solid compound. The shooting of droplets of the actual building material (liquid-to-solid compound) in Drop-on-Demand mode is known as Drop-on-Drop (DOD) deposition, while the shooting of droplets of binder on the powder material is called Drop-on-Powder (DOP), or Drop-on-Bed (DOB) deposition Dimitrov *et al.*, 2007. Table 2.1 shows how different technologies relate to different deposition techniques.

**Table 2.1 Deposition Processes and Corresponding Technologies** (Adapted from Dimitrov *et al.*, 2007)

Aimed Deposition Process	Technology
Drop-on-drop deposition	3D Plotting Multi-Jet Modelling
Drop-on-powder deposition	3D Printing
Continuous deposition	Fused Deposition Modelling

#### 2.2.8.1. DROP-ON-DROP DEPOSITION (DOD)- THERMAL PHASE CHANGE INKJETS

Single- and Multi-Jet systems are used to deposit molten building and support material. The material hardens as its temperature drops. Phase change ink-jets only utilise limited materials and the printed/grown parts are generally fragile (Dimitrov *et al.*, 2007).

- The material is held in a molten state in reservoirs above the machine and is fed to individual jetting heads.
- Each jet deposits tiny drops of the material at specific points as the head moves over the layer along the geometry.
- A milling stage follows each layer to ensure uniform thickness of each layer.
- Clogged jets are cleaned via a cleaning cycle and defective layers are milled away and redone.
- Wax supports are melted or dissolved away after part completion.

- Multiple-jet printers use the same building material to print thin hair-like structures for support and are merely brushed away afterwards.

The Single-Jet system by Solidscape uses two print heads with single jets, one for depositing the thermoplastic building material and the other for depositing supporting wax. They can produce fine surface finishes with exceptional accuracy, but lacks speed. Solidscape Inc. calls it "3D Plotting", (Figure 2.10), (Dimitrov *et al.*, 2007).

The Multiple-Jet system by 3D Systems using its ThermoJet Modeler™ inkjet technology utilizes several hundred nozzles in a wide head configuration to deposit molten plastic. It is less accurate than Solidscape's Single-Jet, but its build times are much quicker (figure 2.11).

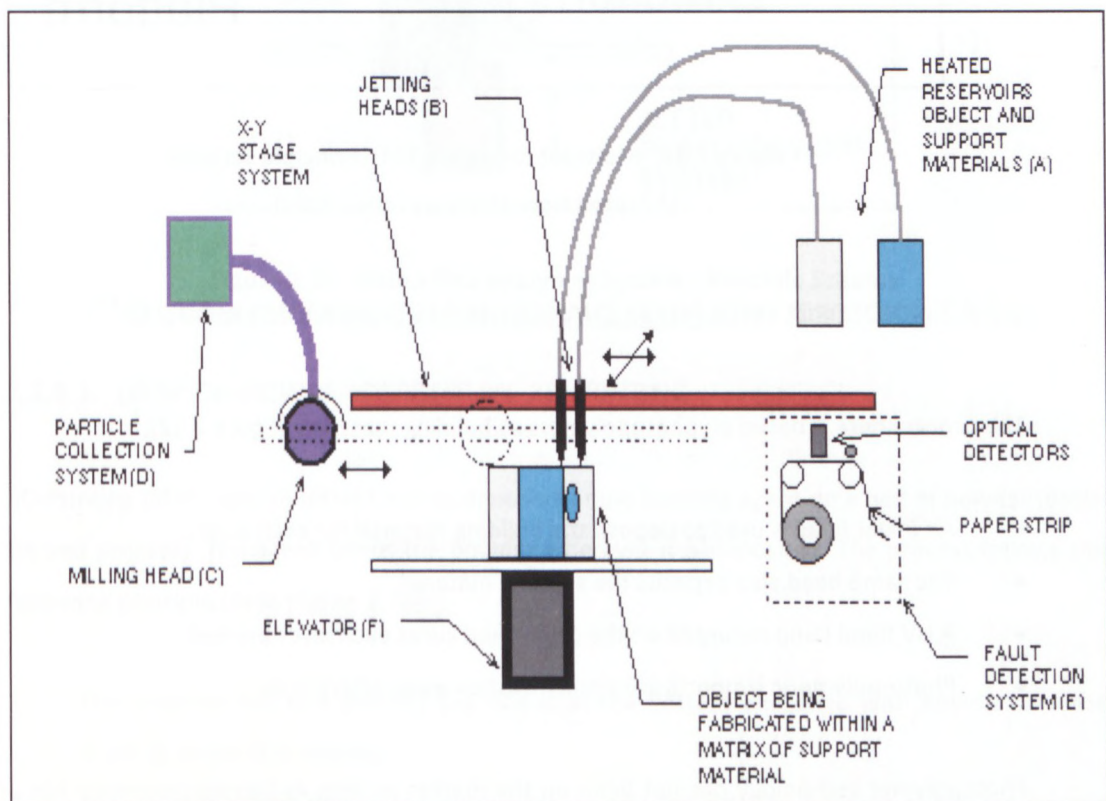

**Figure 2.10 Solidscape's Single-Jet Inkjet - Principle Scheme**  
 (Adapted from <http://home.att.net/~castleisland/>, [12 August 2006])

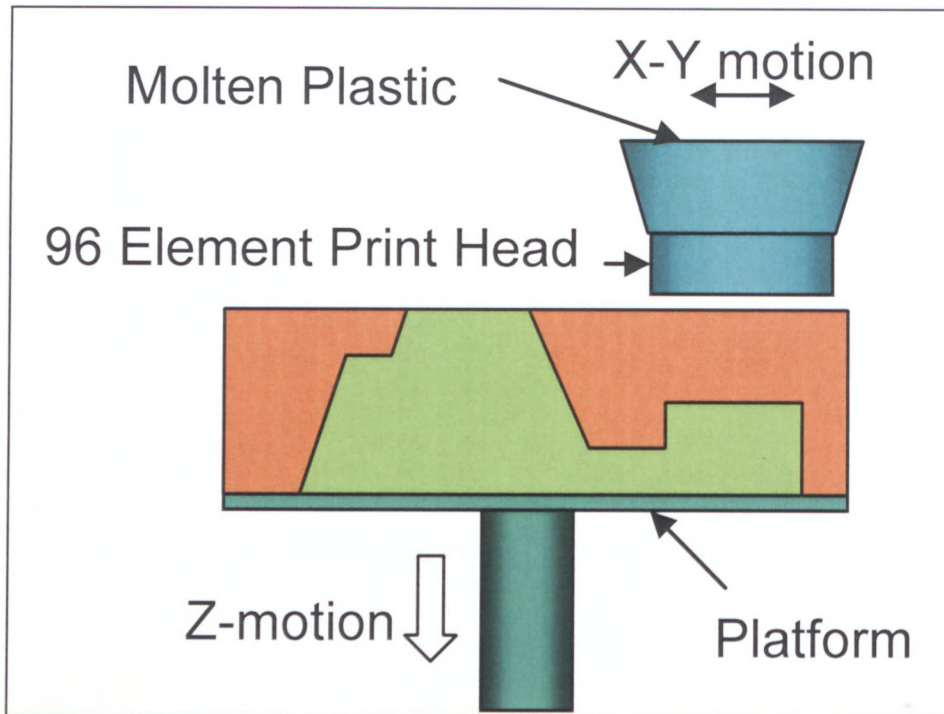

Figure 2.11 Multi-Jet Modelling™ - Principle Scheme

(Adapted from Dimitrov *et al.*, 2007)

#### 2.2.8.2. PHOTOPOLYMER PHASE CHANGE INKJETS (THERMOJET MODELER™)

The process here is based on photopolymers as building materials (figure 2.12):

- An Inkjet head is used to deposit the building material for each layer.
- The same head also deposits the support material.
- A UV flood lamp mounted on the print-head cures each layer printed.
- Photo-polymeric supports are simply washed away afterwards.

Photopolymer technology has not been on the market as long as Stereolithography has and still requires a couple of years for further development to be fully comparable to the development of stereolithography which has been in existence for over 25 years. The PolyJet technology by Objet Geometries Ltd. (an Israeli company, 2000), using their ThermoJet Modeler™ inkjet process (2002), can be seen as typical representative of this method.

A similar photopolymer-based system called InVision™ was introduced by 3D Systems in 2003. The typical application of the Photopolymer Phase Change inkjets is the conceptual modelling, characterised by a high quality of the models built (Dimitrov *et al.*, 2007).

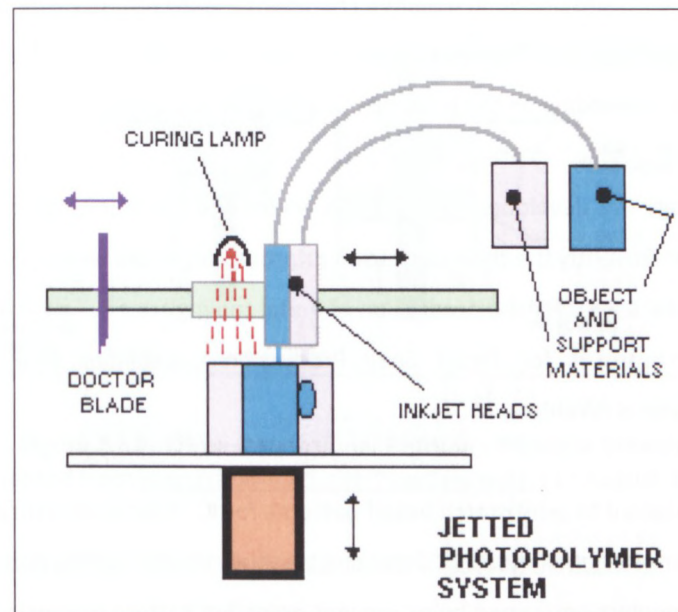

Figure 2.12 Jetted Photopolymer System - Principle Scheme  
(Adapted from <http://home.att.net/~castleisland/>, [12 August 2006])

### 2.2.8.3. DROP-ON-POWDER DEPOSITION- 3D PRINTING

3D-Printing (3DP) uses an inkjet head to deposit a liquid bonding agent on a bed of powder (drop-on-bed process). The agent bonds the powder wherever it is deposited. The process follows the following principle steps (figure 2.13):

1. The machine has two pistons; the one is at the bottom and filled with powder and the building piston is at the top.
2. The powder piston moves one increment up and the print or building piston moves one increment down.
3. The roller moves over to spread a uniform layer of powder over the print piston.
4. The multichannel jetting inkjet head moves over the print piston and deposits a binder liquid along the 2D pattern.

5. The powder piston moves one increment up and the print piston goes one increment down. The process is repeated.
6. After printing, the print piston is elevated and the excess powder brushed away. The fragile part is known as a 'green part'.
7. Green parts are placed in a heated chamber to allow it to dry. The part shrinks as it is dried.
8. The green part is infiltrated to make the part more rigid. The infiltrator could be a hardener or wax, depending on the building material that was used.

3DP technology was developed at MIT, but is licensed to the following companies:

1. Z-Corp: Currently the third most used printer seller in the world (Wohlers, 2007).
2. ProMetal uses it for the production of metal tooling.
3. Soligen uses it for Direct Shell Production Capabilities (DSPC), patterns and other applications (Wohlers, 2007).

3DP can be applied to print starch based patterns for IC. Hollow structures cannot be printed due to the powder entrapment, except if openings are left to remove the entrapped powder. The high porosity of powders entrapped helps prevent excessive pattern expansion and cracking (Cheah *et al.*, 2005). The porous patterns can be infiltrated with wax after printing to obtain a pattern suitable for IC.

ProMetal, a division of Ex One Company, directly converts CAD files into steel mould inserts. An electrostatic ink-jet printing head is used to deposit a liquid binder onto the metal powders. The binder is dried with a drying lamp (Dimitrov *et al.*, 2007).

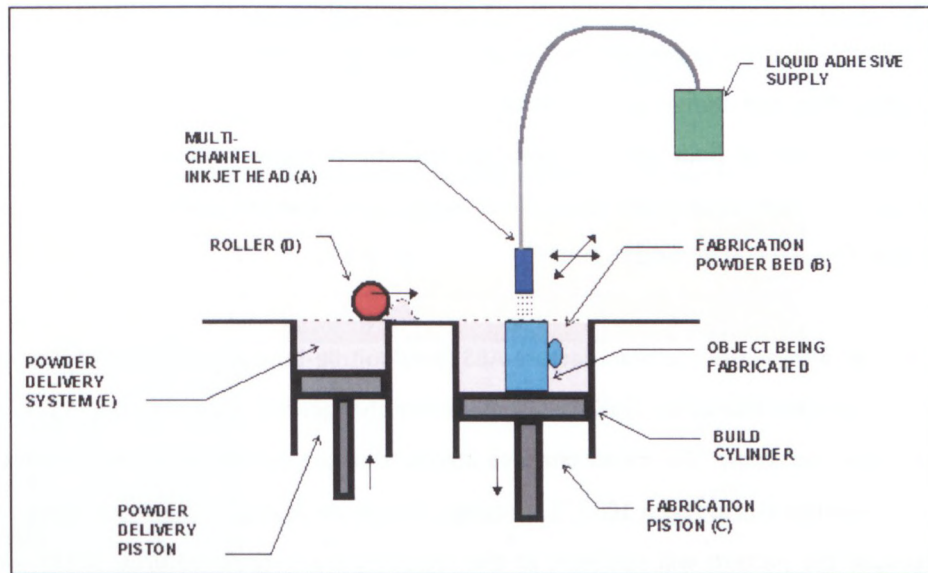

Figure 2.13 Three Dimensional Printing - Principle Scheme  
 (Adapted from <http://home.att.net/~castleisland/>, [12 August 2006])

#### 2.2.8.4. CONTINUOUS DEPOSITION- FUSED DEPOSITION MODELLING

Fused Deposition Modelling (FDM) is the most widely used rapid prototyping technology (Wohlers, 2007). Plastic pellets or filament is fed to an extrusion nozzle which is heated to melt the plastic material. The nozzle is mounted to a mechanical stage which can move in the x, y, and z direction. The nozzle moves over the building table all along the geometry of the new layer and deposits a thin layer of droplets to form the next layer. The plastic quickly hardens and bonds to the layer below after being deposited. The whole building system is within a heated chamber which keeps the temperature just below the melting point of the plastic, resulting in only a small increase in temperature (by the nozzle) needed to melt the plastic (figure 2.14) Blake *et al.*, 1997.

Support structures for any undercuts must be incorporated in the design and constructed. The support structures are later removed. They can be made from nylon-like polymer and certain waxes. Today water soluble support materials are also available. Manufacturing materials include ABS plastic, polycarbonate, poly (phenyl) sulfone, various other polymers, ceramic materials and some metallic materials.

FDM is commercialised by Stratasys. The Fused Deposition Modelling process in combination with the continuous ink jet printing technique is utilised by Stratasys in two of their low cost products - Prodigy Plus and Dimension (Dimitrov *et al.*, 2007). FDM is slow when parts with wide cross sections must be built and stereolithography still provides a better finish. The final product material is non-hygroscopic (absorption of moisture) and the parts are therefore geometrically stable, (Dimitrov *et al.*, 2007).

FDM can also be used to manufacture ABS (acrylonitrile-butadiene-styrene) patterns but wax and elastomers are also used. However, some minor changes are needed to the IC process in order to use these patterns. The minor changes involve that the pattern is placed in a flash fire furnace where temperatures reach 1093 °C, causing the pattern to combust. An autoclave cannot be used because the pattern will not melt at the relatively lower temperatures. Shells are checked for cracks and repaired (Cheah *et al.*, 2005; Blake *et al.*, 1997).

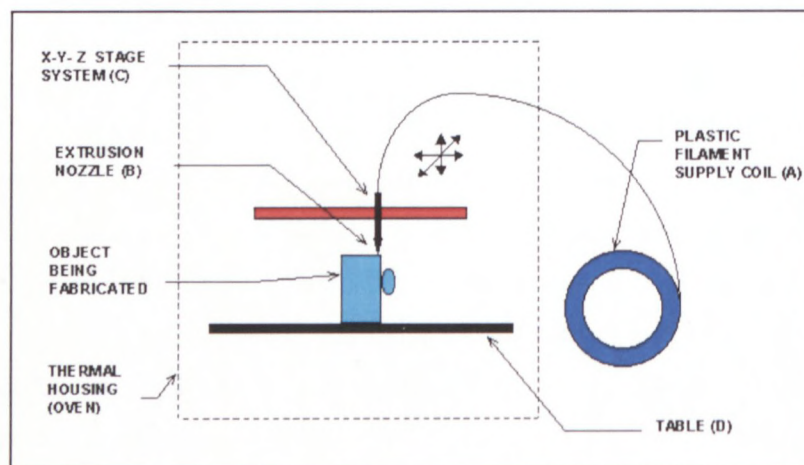

**Figure 2.14 Fused Deposition Modelling - Principle Scheme**  
(Adapted from <http://home.att.net/~castleisland/>, [12 August 2006])

## 2.2.9. SUMMARY OF LAYER MANUFACTURING PROCESSES

Each kind of process technology has its unique area of relevance for investment casting, as well as its own set of advantages and disadvantages. Careful thought must be given when selecting a specific process, because there is a great deal of factors that should be taken into consideration.

Certain processes are better known for their use to create patterns, dies and shells. The better known processes are referred to in table 2.2 and summarized below.

**Table 2.2 LM Processes Applicability to Investment Casting** (Adapted from Hugo, 2008)

Process		Applicability to Investment Casting		
		Patterns	Dies	Shells
1	SLA	X	-	-
2	SLS/LS)	X	X	X
3	FDM	X	-	-
4	LOM	X	X	-
5a	3DP (MM2)	X	-	-
5b	3DP (ThermoJet)	X	-	-
6	3DP(DOB)	X	X	X
7	LENS	-	X	-
8	Direct Metal Deposition	-	X	-
9	EBM	-	X	-
10	DMLS	-	X	-
11	SLM	-	X	-

Patterns (Cheah *et al.*, 2005; Hinckley, 1995):

- FDM and 3DP are already well known to foundries for their wax patterns.
- Due to the fact that non-wax patterns have higher thermal expansion coefficients, shell cracking can be caused during autoclaving. FDM helps to prevent such cracking by allowing for patterns to be built with quasi-hollow structures. SLS and 3DP patterns do not allow the building of hollow structures, (except if there are openings left for powder removal), but they also help to prevent shell cracking through their high porosity.
- SLS, 3DP and FDM patterns have porous surfaces and must be sealed to prevent slurry penetration during shelling.
- The surface finish of almost any pattern can be improved by polishing.

- The amount of ash residue left behind by each pattern differs. SLA and FDM (ABS) leaves small amounts, about 0.02 - 0.05 %. More dense patterns like LOM require longer burnout times and leave larger amounts of ash behind.
- Material cost is an important consideration. ThermoJet patterns are expensive, while the cost of 3DP and LOM patterns are much lower.

Direct Metal Dies (Cheah *et al.*, 2005):

- Laser sintered dies are well known and commercialised under RapidTool and DirectTool. RapidTool dies are strengthened by means of bronze infiltration which also increases density. Reports claim that complex dies are produced in less than two weeks and that they are able to produce 50 000 to 100 000 parts. The DMLS technique is employed for the DirectTool process (EOS) to produce dies that are made from a blend of nickel, bronze and copper-phosphate, with dimensional accuracies of  $\pm 0.05$  %. The density is increased by infiltration with tin, silver and epoxy. EOS also offers DirectSteel, a powder that is steel-based and DirectMetal, a powder that is bronze-based.
- ProMetal is a 3DP technology used to produce dies which are 60 % dense and are infiltrated with bronze afterwards. The 3DP process is relatively fast and offers a variety of metals including tool-steel. Post processing reduces die accuracies to  $\pm 0.1$  mm.
- It has been reported that LENS moulds can produce more than 100 000 injection moulded components, therefore a much greater amount of wax patterns can be obtained from such a die for investment casting. DMD is also used for direct metal die fabrication and allows for inclusion of conformal cooling channels.
- EBM allows for the use of reactive materials like titanium alloys. Solid parts can be built in steel and machined afterwards.
- SLM can build close to 100 % dense dies. Post processing and infiltration is only done if necessary. Surface roughness values of 10 to 30  $\mu\text{m}$  (*Rz*) are possible without finishing. Tooling inserts and parts are built from basically any type of material and the process allows for the inclusion of conformal cooling channels.

Direct polymer or wooden dies (Cheah *et al.*, 2005):

- SLA, FDM, LOM and SLS are used to produce wax-injection dies. FDM produced ABS dies must be infiltrated with epoxy or aluminium-filled epoxy to seal and strengthen them. LOM paper or CNC cut wooden dies must be sealed to prevent moisture absorption.
- Pure non-metal dies have poor thermal conductivity properties and therefore much longer injection cycles are needed. It is however possible to make use of cooling channels.

Direct Shells (Cheah *et al.*, 2005):

- DSPC, a 3DP technology, produces shells with an accuracy of  $\pm 0.2$  mm. Here small batches of fully functional castings are permitted a quick turnaround in a variety of metals.
- The EOSINT M 160 RP system employs LS to directly sinter ceramic shells with accuracies of  $\pm 0.6$  % and surface finishes of 30 – 50  $\mu\text{m}$  according to Cheah *et al.*, 2005.

Various related issues such as shell cracking, hollow structures, ash residue etc., will be more clearly explained in chapter 3.

## 2.3. INVESTMENT CASTING

Literature indicates the following essentials related to investment casting, (Beeley, 2001; Cheah *et al.*, 2005):

- Tolerances of  $\pm 0.15\text{mm}$  are normally accepted for linear dimensions up to 25mm, which extends to  $\pm 1.5\text{mm}$  for sizes of 250mm. Under favourable circumstances, using lower melting point alloys and painstaking process controls these values can be halved.
- Surface finishes of 0.8  $\mu\text{m}$  for aluminium alloys up to 3.2  $\mu\text{m}$  for steels are reported.
- The minimum wall thicknesses are on average between 1 mm to 1.5 mm (depending partly on the area of the section concerned) for metals that can be cast easily such as aluminium alloys. Wall thicknesses of 0.75mm or even less can be achieved for small areas.

### 2.3.1. ADVANTAGES OF CONVENTIONAL INVESTMENT CASTING

Investment casting offers a wide range of advantages. Design flexibility is increased by the wide variety of alloys and the precise detail that can be obtained. The size of parts to cast can range

from a few milligrams up to several kilograms. Investment casting reduces production costs due to minimization or elimination of costly post machining operations.

Fine details can be produced like splines, lettering, holes, serrations, bosses and even threads in some cases. Investment casting is furthermore well suited for metals that are hard to fabricate or machine and it can be used to make parts that cannot be produced by traditional manufacturing techniques. Examples are the complex shapes of turbine blades and aeroplane parts that must be able to withstand high temperatures (Hinckley, 1995).

### 2.3.2. DISADVANTAGES OF CONVENTIONAL INVESTMENT CASTING—COMPARATIVELY

The following disadvantages can be summarized:

- Large quantities of castings must usually be produced to justify the expensive investment in dies, depending on the specific die.
- Full advantage must be taken of the investment casting process to eliminate all machining operations due to the higher casting costs.
- The maximum size of potential castings may be limited.

### 2.3.3. DEFECTS OCCURRING DURING CONVENTIONAL INVESTMENT CASTING

According to Van Wyk (1992) there are generally four types of defects that can occur during investment casting due to poor process control:

#### **Incomplete running**

Incomplete running usually occurs when the casting has thin sections and gravity pouring is inadequate to fill these sections. Positive pressure can be applied to the liquid metal which will force it up the feed tube into the mould cavity to assist filling of mould.

#### **Casting distortions**

Distortions are caused by careless handling of wax patterns .i.e. storing in an area where no temperature control exist, lack of proper supporting of larger patterns and improper processing parameters in the shell making stage.

### **Shrinkage**

Shrinkage can be defined as the amount the cast metal will contract in volume as the material cools down and solidifies. The metal used for the casting determines the amount and is usually given in terms of percentage. Shrinkage defects occur when too little metal is used or when the metal is too cold when poured.

### **Surface markings**

The surface finish of the pattern directly affects the surface finish of the part. Markings can also be caused by careless handling during the casting stages.

## **2.3.4. RAPID INVESTMENT CASTING OVERVIEW**

The Conventional Investment Casting process can be grouped into the following stages:

- Die Making
- Pattern Making
- Shell Making
- Melting of metal
- Casting
- fettling

Rapid prototyping and rapid tooling techniques can be used in each of the stages and therefore it can be called Rapid Investment Casting (RIC).

## **2.3.5. ADVANTAGES OF RAPID INVESTMENT CASTING**

The greatest advantage of using Rapid Prototyping techniques within the Investment Casting process chain is the shortening of the total lead-time to produce a part. Furthermore, RP technologies can be used to make much more complex parts - even parts that were impossible to manufacture before. RP requires no fixtures or tooling and therefore makes manufacturing much easier. RP and tooling techniques can be used by concurrent engineering in order to evaluate parts and tooling through a few iterations which will ensure the best design. Shrinkage allowances for pattern material can be corrected before pattern production and therefore errors can be

eliminated before casting even begins. Although these facts prove to be beneficial during the product development phase, it is only valid in “one-off” or small scale runs.

Certain RP machines can produce non-wax patterns which are much stronger and less fragile than normal wax patterns; these allow thin walled structures to be cast. Non-wax patterns also allow for more post processing in order to increase surface finish.

Die designs can be optimized before manufacturing of expensive permanent dies. RP dies allow the inclusion of conformal cooling channels which provides more effective cooling of the die. This reduces the solidification time of the injected wax, ultimately reducing manufacturing time and cost.

Directly fabricating shells for investment casting can reduce lead time and cost even further due to the elimination of producing a pattern. Shells and cores can be produced as one; hereby eliminating the potential of cores moving and therefore losing geometric accuracy. The shell thickness can be controlled through direct shell fabrication and therefore heat transfer can be controlled to a certain extent. Once again, the success of the concept depends on the particular requirements regarding the number of components needed.

#### 2.3.6. DISADVANTAGES OF RAPID INVESTMENT CASTING

The lack of information on each RP process and the specifications on their various materials can at present be seen as the main disadvantages. Using RIC technology currently relies on the experience of other users and manufacturer’s skills; hence the proposed research.

Each RP and tooling technique uses different materials to produce patterns and dies and thus require different post processing steps before they can be utilized. Various infiltrants must be used to increase strength, density and surface finish of produced parts.

Non-wax patterns produced by certain RP technologies can cause shell cracking due to their high thermal expansion properties. However, certain strategies like manufacturing hollow parts have already been worked on to counter this setback. Non-wax patterns leave more ash residue behind after burnout and require more shell cleaning. Incomplete burnout of patterns can also lead to defects in the final product.

Any marks or defects on the surface finish of a pattern, die or shell produced by rapid manufacturing and tooling, will be replicated in the final casting. Incomplete burnout and cleaning of shells leave residues that create small inclusions which in turn cause casting defects.

Rapid prototyping technology is still in its development years and each of the disadvantages mentioned can be seen as temporary setbacks. Better materials and techniques are constantly being worked on by researchers. Further strategies to counteract certain drawbacks will be investigated in this research.

### 3. LAYER MANUFACTURED INVESTMENT CASTING PATTERNS

The use of rapid prototyped IC patterns comes from the concept that any material can be used as long as it can be burned or melted out without damaging the ceramic shell. The main goal of designing any casting is still to minimise all costs in achieving full functional performance of the part designed. Investment casting is an economical process when thin walled parts with good surface finish and/or complicated parts with undercuts are needed. Applying rapid prototyped parts as patterns for the IC process means that the die-making phase of IC can be eliminated. Such elimination saves time and reduces cost when only one or a few final parts are needed.

Every casting process has various requirements that have to be considered when designing a part. Conventional investment casting wax patterns differ from patterns produced by RP machines mainly due to the different materials used. Using rapid prototyped parts means that certain specific requirements will apply to the design process.

#### 3.1. DESIGN FOR MANUFACTURE

Design for Manufacturability (DFM) is a method or mindset that applies manufacturing principles to design a part. The function of DFM is to design parts that are economical and production of these parts should be kept as simple as possible. Some principles are utilized for efficient manufacturing such as developing a modular design using standard components which allows for design flexibility and multifunctionality. By far the most important principle is to design for ease of manufacture, which in turn depends on the fabrication processes adopted. These guidelines have been well documented (Boothroyd *et al.*, 1994; Hague *et al.*, 2004).

DFM places limitations on the complexity of the part being designed. In casting, the limitations are usually due to the die. The more complex a part the more complex and expensive the tooling (die) will be. Two usual design considerations include the selection of the parting line position and draft angles for pattern removal, however this is not needed for IC. A trade-off for DFM is DFA (Design for Assembly). This requires the integration of multiple parts to reduce the total number of parts.

Probably one of the biggest advantages of layer manufacturing processes is that there is no need for tooling to obtain the patterns. However, in certain cases soft tooling can be used as a secondary method to obtain a better pattern. The elimination of tooling means that most of the DFM principles in the modern manufacturing environment are no longer applicable. "The ability to produce whatever geometry that is created in a 3D CAD system actually means that one is entering a new dimension of 'manufacture for design' rather than the more conventional DFM philosophy"(Hague *et al.*, 2004).

The absence of tooling also means that the need to produce enough parts to justify the cost of expensive tooling is no longer needed. 'Cost-effective custom manufacturing' now becomes more evident.

Certain limitations to parts still apply, like minimum wall thicknesses, minimum feature size, part size, the use of fillets and avoidance of sharp corners. The designer must always work with the foundry and now also with the RP specialist to ensure that all part features and specifications are obtainable.

Specific limitations to RP include [Beeley, 2001; Hague *et al.*, 2004]:

- Poor surface finish
- Lack of dimensional accuracy
- Limited range of materials
- Build time (especially for large components)
- Resolution
- Repeatability
- Cost

Technology has advanced so much in the past few years that some of the limitations mentioned are no longer seen as constraining factors. Manufacturers keep on introducing new materials with better properties, faster machines, better surface finish and higher accuracy.

## 3.2. RAPID PROTOTYPE LIMITATIONS

### 3.2.1. PATTERNS REQUIREMENTS FOR IC

Investment casting has its own specific requirements concerning the patterns used for casting. Two important requirements include pattern accuracy and low ash content. A third important requirement is the thermal expansion properties of the pattern's material used.

#### 3.2.1.1. ACCURACY

Accuracy is a vital concern in investment casting patterns. The required accuracy of a pattern is debatable. Solidform, an aluminium investment casting foundry in Fort Worth, Texas, uses a rule of thumb where the pattern tolerances are at least equal or smaller than half the tolerances on the final casting. For example, if the casting dimension tolerances are + 0.025, then the pattern dimension tolerances should be + 0.0125, (Mueller, 2005).

The most influential elements affecting the build accuracy are the basic process properties such as the scaling factor and the build parameters. Different materials and applications require different scale factors and saturation values. These are usually recommended by the system manufacturers. Environmental conditions can also have a significant effect on the recommended build parameters. Even the specific build location within the building envelope of a RP system influences the pattern accuracy. (The build orientation will be discussed later.) The achievable accuracy is to a large extent determined by the skill and experience of the user and the manner in which the post processing is carried out.

Effects of shrinkage usually can cause warping and curling. Curling is an adverse result of shrinkage and residual stress. Certain RP parts are greatly affected by moisture. Parts absorb moisture and warp and/or swell. Photopolymer type processes typically tend to be significantly affected. For example, SLA and Polyjet parts are affected by moisture but SLS and FDM parts are not affected (Grimm, 2002).

### 3.2.1.2. ACCURACY OF MEASUREMENT

Measuring accuracy can be influenced by various factors. These are typically the choice of axis to be measured, machine calibration, part orientation, type of features, time of day, environmental exposure etc.

Some of the main sources of error in RP are as follows (Tong *et al.*, 2004; Dimitrov, 2006 b):

- Occurrence of the staircase effect due to restricted layer thickness
- A STL file approximation error
- Location errors of deposition nozzles (printing heads) or laser beams
- Material properties and the age of the material
- Shrinkage and expansion of parts during the RP process
- The application of shrinkage rates

### 3.2.1.3. LOW ASH CONTENT

The investment casting process involves melting or vaporizing the pattern from the shell. The pattern that is removed by being melted or vaporized usually leaves a small amount of residue behind. Low ash content indicates how well all shell cavities will be cleaned after shell firing. Ash residue trapped in tight cavities or deep recesses might be difficult to remove or even impossible.

Ash residues left after burnout of patterns must be controlled because they affect the quality of the final castings. The ash residues serve as inclusions which causes defects in castings.

Mostly wax patterns are used for investment casting which leaves a low ash content after melting. Each RP process makes use of different materials and therefore each case has different ash residue properties. To the investment caster it is important that these new RP patterns have similar or less ash residue than the conventional investment casting waxes used.

During the last few years RP materials that were used have improved so much that ash residue is no longer such a problem. Certain RP patterns like, for example, LOM still might contain substantial ash residue (Hugo, 2008).

#### 3.2.1.4. THERMAL EXPANSION

The thermal expansion coefficient of materials used for patterns must be as small as possible. After the ceramic coating of patterns, the pattern must be removed by melting it out in an autoclave or firing it in a furnace. The pattern and shell usually expand when heated and cause the shell to crack due to the shell's and pattern's thermal expansion coefficients clashing. Operating temperatures must always be closely monitored to control expansion.

Various methods are being used to overcome this problem, namely (Cheah *et al.*, 2005; Beeley, 2001):

- Firstly try using patterns with the minimum thermal expansion coefficient or ones that softens or melts easily at low temperatures.
- A flask (solid mould) casting can be used to prevent shell cracking.
- Wax patterns can be removed by quickly heating the shell with steam. This causes the outer layer of the pattern to quickly melt, therefore leaving room for the rest of the pattern to expand.
- Certain RP processes allow the building of hollow patterns, where the pattern easily softens and collapses when heated and shell cracking is avoided (Cheah *et al.*, 2005).
- Additional advantages include a faster building time, a drop in material cost and less residue because less material is used.

One of the first methods were QuickCast, where the inside of the pattern is grown with small raster formation structures, leaving the pattern partly hollow (quasi-hollow structures). Small holes are left in the pattern to allow excess resin to escape. The pattern also collapses after heated to prevent shell cracking. As before the build time is faster, material cost decreases and there is less material, therefore less ash residue left behind. QuickCast build styles can reduce 60 to 95 % of the internal mass of epoxy (SLA) and ABS (FDM) patterns, resulting in ash residues of 0.02-0.05 % (Cheah *et al.*, 2005). Solidiform, Inc. is a leading provider of aluminium investment castings from direct patterns and one of the first foundries to develop the capability to process QuickCast patterns. Solidiform was the initial beta site for 3D Systems' QuickCast development effort (Mueller, 2004).

Patterns with dense structures, that require longer burning out time, result in much higher ash residue, i.e. LOM patterns.

#### 3.2.1.5. REMOVAL OF RESIDUAL ASH

Patterns never completely burn out and the ash left behind must be removed. Research based on LOM patterns experimented with many ways of ash removal. Multiple liquids have been tried, hoping that it would dissolve the LOM pattern ash residues and wash it out. The liquids must be strong enough to dissolve the ash without affecting the surface of the shell. In previous experiments acetone, pure lye, drain cleaner and hot soapy water was tested, but the attempts were unsuccessful (Hinckley, 1995).

Residual ash is generally removed by flushing the cooled shell with compressed air or water. Shells must be dried properly as water rapidly vaporises at molten metal temperature and can be dangerous. Cooled shells are reheated before pouring molten metal. Mould vents help accelerate pattern burnout, but increase the post processing time.

Firing duration, shell thickness and firing temperature have a clear effect on the ash left behind after burnout. In previous studies various plots have been established: of burnout time versus shell thickness versus cleanliness and time versus temperature versus cleanliness (Hinckley, 1995).

LOM patterns previously caused shell cracking during firing. The layer roughness of patterns absorbed moisture from the slurry which caused the cracking on firing. Firstly patterns were dipped into thick liquids like wax and epoxy, but these changed the part size and tolerance, which was unacceptable. Secondly sprayed-on coatings like primer and acrylic were used; these gave the appropriate water-tight sealing without changing part dimensions. Clear acrylic enamel spray worked best. However, with sufficient surface finish the patterns required no sealing. Long firing times left a white flaky ash which can easily be removed by air. Wood putty fillers and primers should not be used, because they leave additional ash after firing (Hinckley, 1995).

### 3.2.1.6. BUILD ORIENTATION

Selecting the optimal build orientation for building parts on RP machines directly affects the part quality, part cost, build time and support structures. Build orientation can be seen as one of the critical factors to control part cost, quality, use of support structures and time.

All factors cannot be optimized at once and there is usually some trade-off. Various studies have been done to find ways and methods to determine the best trade-off for a specific situation. The majority of studies focus on finding some algorithm to determine the best build orientation.

Surface roughness is mainly due to the staircase effect caused by the layering process. The contact areas of supports also influence surface quality.

The following illustration (figure 3.1) presents some basic ideas regarding build orientation (Jibin *et al.*, 2005).

- a Figure (a) presents the best surface finish due to no staircase effect encountered, but the added layers results in a longer building time required.
- b Figure (b) will take less building time, but will have more surface roughness due to the staircase effect on the surface.
- c Figure (c) requires some supports for the surface and the part is in an unstable position.

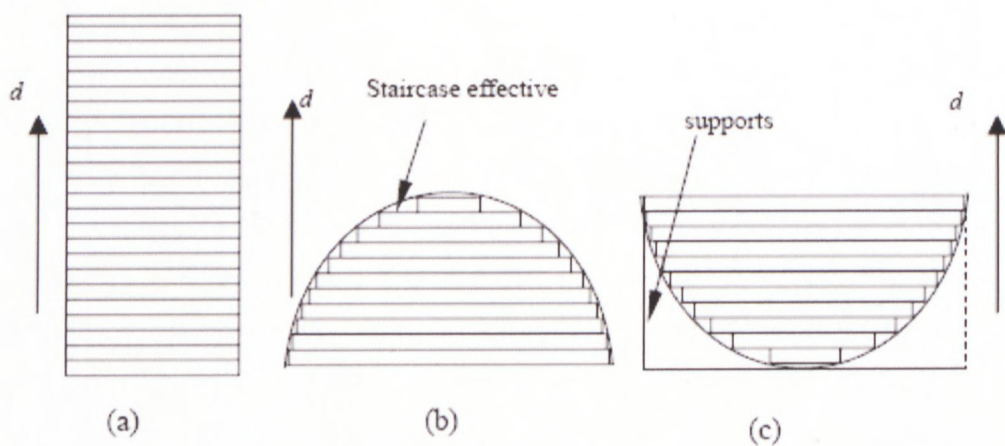

**Figure 3.1** Effects of build orientation  
(Adapted from Jibin *et al.*, 2005)

Build time is directly dependent on the number of slices, therefore the height of a part. Adding support structures also influence build time. According to Hong *et al.*, 2006, it is hard to calculate an accurate build time since it is difficult to consider all the process parameters, including the acceleration and deceleration of a nozzle or a laser beam. Basic build time parameters consist of platform movement, sweep period, z-wait, tip cleaning time, roller movement, part bed movement, chamber movement, system delay, warm up time, build time for each layer, curing time and cooling down time; all depending on the type of system used.

Part cost is another important factor to consider when determining build orientation. Estimations of part cost for different build orientations can be made. Part cost consists of labour time, raw material cost and support material cost. The time component will consist of pre-processing time, post processing time like removal of supports and actual build time, each of which involves a certain cost portion.

### 3.2.2. COMPONENTS EXCEEDING WORK ENVELOPE OF LM MACHINES

The building envelopes of RP machines are limited in size. Large parts that exceed the build envelope of these machines are being required more often. Parts can however be split into multiple sections and assembled after being built separately. Such parts need to conform to a certain level of strength, accuracy and surface finish, which makes the RP process a much more difficult task.

In theory one would like to develop various strategies to slice up these parts to allow for the highest accuracy, strength and surface finish after assembly. However, every part differs in size, geometry, complexity, wall thickness, undercuts, internal cavities etc. and therefore it is difficult to develop one strategy to suit all these situations.

The way in which a large part is sliced, is mainly determined by the experience and proficiency of each rapid prototypist. A case study of such a large part is therefore discussed in chapter 5 for illustrative and experimental purposes.

## 4. RESEARCH APPROACH AND METHODOLOGY

The following chapter describes in detail the specific component selected for the effective analysis of three selected core layer manufacturing technologies namely: 3DP- Z-Corp, LS-EOS and DOD-ThermoJet. These methods have been selected due to their current availability in South Africa.

Due to the sheer scale of this research in its entirety, the following methodology and descriptions of the techniques have been adopted from Hugo, 2008 to provide continuity and baseline for comparative purposes for the AMTS.

### 4.1. DIMENSIONAL AND GEOMETRIC ACCURACY: TERMS AND DESCRIPTIVE STATISTICS

#### 4.1.1. DESCRIPTIVE STATISTICS

The following statistical definitions are given according to Montgomery *et al.*, 2003:

- a. **Error Distribution Function (EDF)** is a histogram that plots the frequency of each size of error against the different sizes of errors. A histogram can be used to visually detect any abnormal observations like outliers or gaps in the data set. The EDF can furthermore be used to show if the errors are systematic or random. As long as the function is symmetric and centred around zero, meaning that half of the errors are positive and the other half negative, the error is random. Any shift from symmetry indicates the occurrence of a systematic error.
- b. **Mean:** In mathematical terms the mean is the overall sum off all the deviations divided by the number of observations.
- c. **Standard Error:** The standard error of an estimator is its standard deviation. Standard error depends on the sample size; the larger the sample size, the smaller the standard error. Standard errors reflect how much sampling fluctuation a statistic will show.

- d. **Median:** The median is the value where roughly half of the data are smaller and roughly half of the data are larger, reflecting the central tendency of the sample.
- e. **90th Percentile:** A percentile is a value on a scale of 100 that indicate the percent of a distribution that is equal to or lower than it. For example: from all the measurements taken, it can be stated that at least 90 % of the values will be within the required value reported.
- f. **Mode:** The mode is the value that most frequently occurs in the data set.
- g. **Standard deviation:** Standard deviation is a measure of the spread (or dispersion) of a set of data values. Standard deviation increases as the values spread wider apart.
- h. **Sample variance:** Sample variance is a measure of the spread (or dispersion) within a set of sample data. It is the square of the sample standard deviation. Variance is an unbiased estimator.
- i. **Kurtosis:** Kurtosis refers to the way in which the peakedness of the distribution is measured. Basically it measures the extent to which probability is concentrated around the mean and in the tails compared to a normal distribution. A normal distribution has a kurtosis coefficient of 3.
- Platykurtic            <3      Low peak and flat midrange distribution.
  - Leptokurtic           >3      High peak, thin midrange and fat tails distribution.
  - Mesokurtic            =3
- j. **Symmetry:** Symmetry refers to when the observation values are distributed in the same means above and below the middle of the sample.
- k. **Skewness:** Skewness refers to the phenomenon where values on the one side of the sample's data distribution are further from the middle than the values on the other side. Skewness is also defined as asymmetry in the distribution of the values. Positive values for skewness indicate that the distribution is hanging over to the left and negative values that the distribution is hanging to the right.

- l. **Range:** The range is the difference between the largest and smallest value of all the observations in the sample. It is also an indicator of variability that is used to characterize the dispersion among the measures in a given population.
- m. **Minimum:** The minimum is the smallest value in the group of values.
- n. **Maximum:** The maximum is the largest value in the group of values.
- o. **Sum:** The sum is the addition of all the values in a sample, and also takes the sign of each value into account.
- p. **Count:** The count is the number of values in the sample.
- q. **Confidence interval:** A confidence interval gives an approximate range of values which is likely to include the unknown population parameter. By taking independent samples repeatedly, a certain percentage of the samples will contain the specified parameter. The width of the interval gives an indication of how unsure we are about the unknown parameter.
- r. **Confidence level:** The confidence level is associated with the confidence interval and is the possibility that the interval, that will result once data is collected, will contain the corresponding parameter. It is usually expressed as a percentage.

#### 4.1.2. ANOVA ANALYSIS (SINGLE FACTOR)





ANOVA single factor analysis is used to perform a simple analysis of variance on data for two or more samples. According to ISO 1101:2001 “The analysis provides a test of the hypothesis that each sample is drawn from the same underlying probability distribution against the alternative hypothesis that underlying probability distributions are not the same for all samples”.





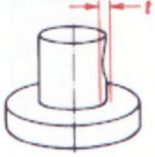





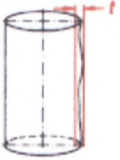

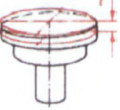

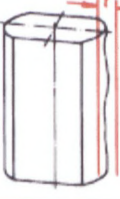
The hypothesis should be rejected if  $F$  is larger than  $F_{crit}$  or if the  $P$ -value is smaller than the alpha ( $\alpha = 0.05$ ) value.

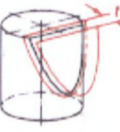



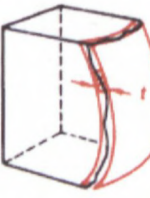

#### 4.1.3. DIMENSIONAL AND GEOMETRIC ACCURACY RELATED TERMS

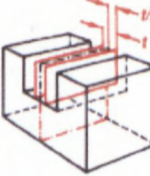
The following are definitions obtained from ISO 1101:2004 standards.

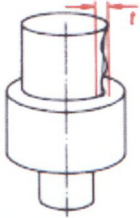
**Table 4.1 Geometric Tolerance Descriptions** (Adapted from ISO standards)

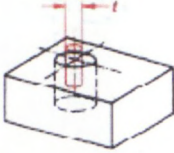
Type	Description	Symbol	Diagram
<b>Perpendicularity</b>	The tolerance zone is limited in the measuring plane by two parallel, straight lines a distance $t$ apart and perpendicular to the datum.		
<b>Roundness</b>	The tolerance zone is limited in the measuring plane perpendicular to the axis by two concentric circles a distance $t$ apart.		
<b>Cylindricity</b>	The tolerance zone is limited by two coaxial cylinders a distance $t$ apart.		

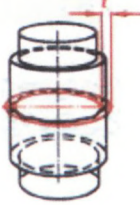
<b>Straightness</b>	The tolerance zone is limited in the measuring plane by two parallel straight lines a distance $t$ apart.		
<b>Flatness</b>	The tolerance zone is limited by two parallel planes a distance $t$ apart.		
<b>Parallelism</b>	The tolerance zone is limited in the measuring plane by two straight lines a distance $t$ apart and parallel to the datum.		
<b>Angularity</b>	The tolerance zone is limited by two parallel planes a distance $t$ apart and inclined at the specified angle to the surface.		
<b>Concentricity/ Coaxiality</b>	The tolerance zone is limited by a cylinder of diameter $t$ , the axis of which coincides with the datum axis.		
<b>Profile of a line</b>	The tolerance zone is limited by two lines enveloping circles of diameter $t$ , the centres of which are situated on a line having the true geometrical form.		
<b>Profile of a surface</b>	The tolerance zone is limited by two surfaces enveloping spheres of diameter $t$ , the centres of which are situated on a surface having the true geometrical form.		
<b>Symmetry</b>	The tolerance zone is limited by two parallel planes a distance $t$ apart and symmetrically disposed to the median plane with respect to the datum axis or datum plane.		

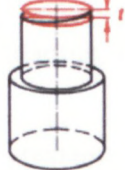
<p><b>Conicity</b></p>	<p>The tolerance zone is limited in the measuring plane by two straight lines a distance <math>t</math> apart and parallel to the datum. Not the measured profile, but that section of the reference straight line calculated according to <b>LSS</b> which is restricted to the measuring length shall be contained within the tolerance zone. (LSS = Least Square Straight line)</p>		
<p><b>True Position</b></p>	<p>If the tolerance value is preceded by the sign <math>\perp</math>, the tolerance zone is limited by a cylinder of diameter <math>t</math>, the axis of which is in the theoretically exact position of the tolerance line.</p>		
<p><b>Runout (Radial)</b></p>	<p>The tolerance zone is limited in the measuring plane perpendicular to the axis by two concentric circles a distance <math>t</math> apart, the common centre of which lies on the datum axis.</p>		
<p><b>Total Runout (Total Axial)</b></p>	<p>The tolerance zone is limited by two parallel planes a distance <math>t</math> apart and perpendicular to the datum axis.</p>		
<p><b>Squareness</b></p>	<p>See Perpendicularity</p>		

## 4.2. SURFACE QUALITY

There are two main reasons for measuring surface finish. In the first place it helps to forecast the performance of machined parts like pistons and secondly it also helps to control manufacturing processes.

According to Campbell *et al.*, 2002, the quality of a part's surface consists of three basic components: the form, its waviness and its roughness. On a turned part, form is the result of errors in the way the lathe produces a part, commonly known as straightness errors, and waviness is a result of various vibrations, both in the machine tool and from outside sources. Roughness, on the other hand, is the result of feed-rate tool, geometry, tool condition, and variations in material and hardness. Surface quality can be measured in multiple ways and is presented by various parameters. Each parameter differs from the next and sometimes more than one parameter is used to adequately describe a surface. The most frequently used parameter is *Ra* (Arithmetic Average Roughness), which resembles the average roughness measured from a centre line.

## 4.3. COMPONENT SELECTION FOR RESEARCH

The component used for this study is shown in figure 4.1. It was designed within tooling projects from the FP6 Framework of the EC and used for similar studies, (European Commission, 2006).

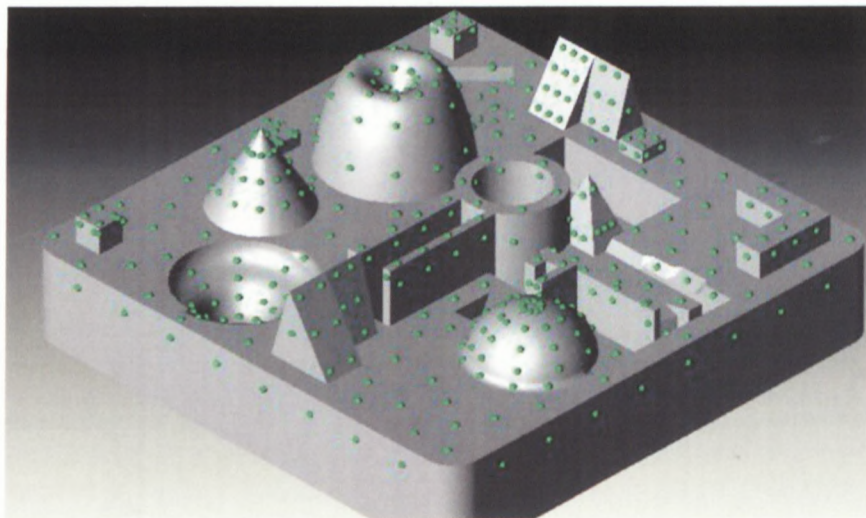

Figure 4.1 EC FP6 Benchmark Part

The dies (figure 4.2) will represent an exact negative of the pattern, but will include a shrinkage allowance for the investment casting wax to be used. Wax patterns from the dies will be evaluated in order to determine the suitability of the dies for creating investment casting patterns.

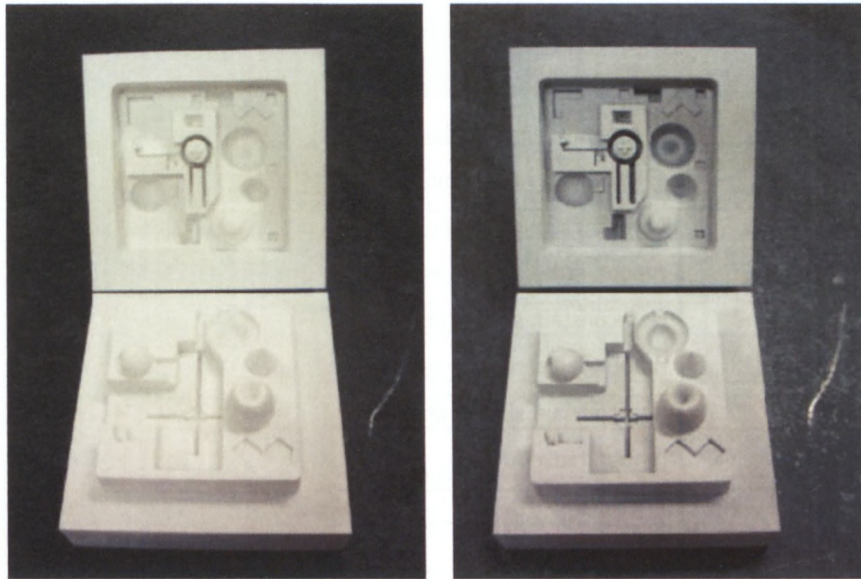

Figure 4.2 Polyamide and Alumide Dies

Basic description of part:

<b>Size</b>	Medium
<b>Dimensions</b>	150 x 150 x 25 base
<b>Features Incorporated</b>	Spherical, Cone, Pyramid, Squares, Cylindrical, Triangles, Thin wall, Square holes etc.
<b>Complexity of measurement</b>	Straightforward using CMM programmed measurements

A range of features will be measured according to certain geometric tolerances. The range of feature measurements is marked in Figure A, Figure B and Figure C in Appendix A. Each feature incorporated on the benchmark part has a certain purpose for the benchmarking process and is used to measure specific tolerances. Table 4.2 lists the various features on the benchmark part and the purposes of each of them. The same features will be measured on LM patterns, LM dies and wax patterns from LM dies.

Table 4.2 Feature Definitions

Feature	Purpose	Quantity and Nominal sizes
<b>Cubes</b>	Straightness, repeatability, linear accuracy	2 (8 x 8 x 8 mm ) 2 (8 x 8 x 4 mm ) (Half-Cube)
<b>Rectangular protrusion</b>	Perpendicularity, linear accuracy	1 (25 x 8 x 8 mm)
<b>Pyramid</b>	Angularity, accuracy	1 (12 x 17 x 20 mm)
<b>Sphere (half)</b>	Symmetry, repeatability of a constantly changing sloping profile, axial runout, radial runout	1 (ø35 mm)
<b>Cone</b>	Constant sloping profile, taper, axial runout, radial runout, symmetry	1 (ø30 x 26 mm)
<b>Free-form (conical)</b>	Non-constant sloping profile, axial runout, radial runout, symmetry	1 (ø40 x 30 mm)
<b>Free-form (sinkhole)</b>	Non-constant sloping profile, axial runout, radial runout,	1 (ø30 x 20 mm)
<b>Wedges</b>	Angularity	(X direction 20 x 20 mm) (Y direction 20 x 25 mm)
<b>Rectangular Hole</b>	Perpendicularity,	1 (25 x 8 x 5 mm)
<b>Cylindrical Hole/ Hollow Cylinder</b>	Concentricity, circularity, accuracy	1 (ø30 x ø20 x 27 mm)
<b>Triangular Hole</b>	Angularity, perpendicularity	1 (10 x 8 x 4 mm)
<b>Flat Thin Walls</b>	Parallelism, thickness	1 (35 x 27 x 5 mm) 1 (35 x 27 x 3 mm)
<b>Square base</b>	Flatness, straightness, parallelism	1 (150 x 150 mm )
<b>Mechanical Features</b>	Competence of machine to build particular features ( <b>Visual Inspection</b> )	Free-form, Chamfer, Fillet
<b>Yes/No Features</b>	Machines ability to build certain features ( <b>Visual Inspection</b> )	Small triangular hole, Small cross-shaped hole, Thin walls

Table 4.3 lists all features and the type of tolerances to be measured. Using standardized measurement techniques on the same benchmark part can decrease variability between the measurement results of the various layer manufactured parts.

**Table 4.3 Features and Tolerance Measurements**

Tolerance No.	Feature	Tol. Element Name	2 <sup>nd</sup> Element Name	Type of Tolerance
A1–A16	See Drawings	Line	Point	Distances
B1–B2	See Drawings	Line	Point	Distances
C1–C6	See Drawings	Line	Point	Distances
CC3–CC5	See Drawings	Line	Point	Distances
D1–D5	See Drawings	Line	Point	Distances
D5	See Drawings	Line	Point	Distances
E1–E12	See Drawings	Line	Point	Distances
EE1–EE3	See Drawings	Line	Point	Distances
AA1	Wedge X-direction	Line	Line	Angularity
AA2	Wedge X-direction	Line	Line	Angularity
AA3	Wedge X-direction	Line	Line	Angularity
BB1	Wedge Y-direction	Line	Line	Angularity
BB2	Wedge Y-direction	Line	Line	Angularity
BB3	Wedge Y-direction	Line	Line	Angularity
CC1	Pyramid	Line	Line	Angularity
CC2	Pyramid	Line	Line	Angularity
DD1	Pyramid	Line	Line	Angularity
DD2	Pyramid	Line	Line	Angularity
T1	Triangular Hole	Line	Line	Perpendicularity
T2	Cylinder Hole/ Hollow Cylinder	Outer Circle	Inner Circle	Circularity
T3	Cylinder Hole/ Hollow Cylinder	Outer Circle	Inner Circle	Concentricity
T4	Cylinder Hole/ Hollow Cylinder	Outer Circle	Inner Circle	Circularity
T5	Square Base	Plane		Flatness
T6	Square Base	Left Side	Bottom Side	Perpendicularity

T7	Square Base	Topside	Right Side	Perpendicularity
T8	Square Base	Left Side	Right Side	Parallelism
T9	Square Base	Topside	Bottom Side	Parallelism
T10	Thin Walls	Line	Line	Parallelism
T11	Thin Walls	Line	Line	Parallelism
T12	Thin Walls	Line	Line	Thickness
T13	Thin Walls	Line	Line	Thickness
T14	Cube's 2,3,1	Cube 2, 3, 1		Straightness
T15	Cube's 1, 4, Rect.Protrusion	Cube 1, 4, Rect.Protrusion.		Straightness
T16	Rectangular Protrusion Outer	RecP2	RecP1	Perpendicularity
T17	Rectangular Protrusion Inner	RecP4	RecP3	Perpendicularity
T18	Rectangular Hole Outer	RecH4	RecH3	Perpendicularity
T19	Rectangular Hole Inner	RecH1	RecH2	Perpendicularity
T23	Cone	Actual Cone Axis	Cone	Symmetry tol. axis element
T24	Cone	Cone Bottom Circle	Cone	Circular runout
T26	Cone	Cone Bottom Circle	Theoretical Cone Axis	Circular runout
T27	Cone	plane_2	Theoretical Cone Axis	Axial runout
T29	Cone	plane_2	Cone	Axial runout
T31	Cone	Cone	plane_2	Symmetry tol. axis element
T32	Cone	Cone Bottom Circle	Cone	Symmetry tol. point element
T33	Cone	Cone	plane_2	Angularity
T34	Cone	Cone	Theoretical Cone Axis	Coaxiality
T36	Cone	Cone	Actual Cone Axis	Coaxiality

T37	Cone	Cone Bottom_ Circle	Actual Cone Axis	Circular runout
T38	Sphere	Sphere Bottom Circle	Theoretical Sphere Axis	Circular runout
T39	Sphere	Sphere Bottom Circle	Actual Sphere Axis	Circular runout
T40	Sphere	plane_2	Theoretical Sphere Axis	Axial runout
T41	Sphere	plane_2	Actual Sphere Axis	Axial runout
T42	Sphere	plane_2	Sphere	Symmetry tol. plane element
T43	Sphere	Theoretical Sphere Axis	Sphere	Symmetry tol. axis element
T47	Sphere	Sphere Bottom Circle	Sphere	Symmetry tol. point element
T50	Sphere	plane_2	Actual Sphere Axis	Perpendicularity
T51	Sphere	Actual Sphere Axis	Theoretical Sphere Axis	Coaxiality
T52	Sphere	Sphere	Sphere Bottom Circle	Concentricity
T54	Dome	Dome Bottom Circle	Actual Dome axis	Circular runout
T56	Dome	Dome Upper Circle	Actual Dome axis	Circular runout
T58	Dome	plane_2	Actual Dome axis	Axial runout
T65	Dome	Dome Bottom Circle	Dome Upper Circle	Symmetry tol. point element
T67	Dome	plane_2	Actual Dome axis	Perpendicularity
T69	Dome	Dome Upper Circle	Dome Bottom Circle	Concentricity
T70	Sinkhole	Sinkhole Upper Circle	Theoretical Sinkhole axis	Circular runout
T71	Sinkhole	Sinkhole Upper Circle	Actual Sinkhole Axis	Circular runout

T72	Sinkhole	Sinkhole Bottom Circle	Theoretical Sinkhole axis	Circular runout
T73	Sinkhole	Sinkhole Bottom Circle	Actual Sinkhole Axis	Circular runout
T74	Sinkhole	plane_2	Theoretical Sinkhole axis	Axial runout
T79	Sinkhole	Theoretical Sinkhole Axis	plane_2	Symmetry tol. axis element
T81	Sinkhole	Actual Sinkhole Axis	Theoretical Sinkhole axis	Symmetry tol. axis element
T82	Sinkhole	Sinkhole Bottom Circle	Sinkhole Bottom Circle	Symmetry tol. point element
T84	Sinkhole	plane_2	Actual Sinkhole Axis	Perpendicularity
T85	Sinkhole	Actual Sinkhole Axis	Theoretical Sinkhole axis	Coaxiality
T86	Sinkhole	Sinkhole Bottom Circle	Sinkhole Lower Circle	Concentricity

#### 4.4. EVALUATION METHODOLOGY

The following section describes the measurement methodology developed specifically for the evaluation of all the manufactured parts. The CMM machine used is a Mitutoyo Bright 710 with a calibrated accuracy of 5 $\mu$ m and volumetric accuracy of 6.1 $\mu$ m.

##### Basic CM Machine Procedure:

- a) Switch on all the equipment and start up the software.
- b) Mount the calibration ball on the CMM table.
- c) Insert the 2x20 probe.
- d) Select the calibration program, select the 2x20 probe and select the calibration angles needed.
- e) Manually select 1 point on top of the calibration ball.
- f) The program automatically runs the machine and calibrates the probe at all selected angles.

- g) Save the calibration settings.
- h) Remove the calibration ball from table and make sure the table is clean.

#### Part Measurement

Two measurement programs were pre-written to measure each part. Hereby the consistency of measurements was ensured, because the same point on each part was measured. The first program basically used  $\pm 600$  measured coordinate points on each part which were used to perform a statistical analysis. Statistica 7 Software was employed to do an ANOVA analysis. The software compares (Mitutoyo COSMOS V1.5. and 3D-Tol V2.4.R9) the points measured to the original CAD model of the part and calculates the differences in the x, y and z directions. The second program measures various distances, angles and tolerances, all used to do various tolerance evaluations.

#### Basic Part Setup and Measurement Procedure:

- a. Mount the part to the CMM table using a glue gun.
- b. Select and start-up the program.
- c. Manually select the x and y direction of the part.
- d. Manually select the z plane.
- e. Manually select the cylinder centre as the zero point of all axes.
- f. The program then automatically measures each point as programmed.
- g. The program written automatically calculates a 'Best Fit' for the data.
- h. A manual 'Best Fit' can also be done after the program finishes.
- i. Save the final data (data can be exported to an excel file).

To help evaluate the data, a DAI (Dimensional Accuracy Index) is created for each part measured. An arbitrary upper and lower tolerance was set at +0.5 mm and -0.5 mm respectively. The tolerance is used to determine a certain level of accuracy for the purpose of determining the capability of each of the LM manufacturing processes (table 4.4). The DAI is only an estimation method used to determine the dimensional accuracy of a part as a percentage. The descriptive statistics indicate how accurate the part statistically is. The descriptive statistics and ANOVA analysis should be used for final decision making of part accuracy.

**Table 4.4 Dimensional Accuracy Index Tolerances**

Rating	Tolerance	Remark
High	> 0.5	Outside tolerance
Good	> -0.5 and < 0.5	Inside tolerance
Low	< -0.5	Outside tolerance

Each 'good' measurement can be seen as successful and the total number of successes determines the percentage of successfulness, namely the dimensional accuracy index, Montgomery *et al*, 2003.

$$DAI = \frac{Good}{Total} \times 100\%$$

Basic Data Usage Procedure

- a. Extract the data and organize it in an Excel sheet.
- b. Use Excel and Statistica 7 to calculate basic statistical values.
- c. Create an error distribution function (EDF) of the data (histogram).
- d. Analyze the statistical (Statistical Accuracy) and tolerance data and compare it to previous parts measured.
- e. Calculate the DAI for each part and compare them to other parts. (Dimensional Accuracy)
- f. Do an ANOVA analysis of the statistical data.
- g. Use the statistical analysis and ANOVA analysis for final accuracy decisions.

Surface Quality Measurement Procedure

- a. Switch the surface tester on.
- b. Calibrate the machine.
- c. Select *Ra* and a Cut-off length on the machine.
- d. Place the machine on a surface to be tested, making sure that the bottom surface of the machine is securely placed on a surface.
- e. Start the machine and take measurement.
- f. Repeat the measurements for various features and log.

#### 4.5. INVESTMENT CASTING FACILITY – COUNCIL FOR SCIENTIFIC AND INDUSTRIAL RESEARCH (CSIR)

The CSIR has been a major technology partner during the course of this research and has provided all the investment casting needs for this research.

##### Counter gravity casting machine

Metal is melted in the furnace section of the machine and the shell is placed in the mould chamber. Upon the molten metal reaching the desired temperature, the mould nozzle is plunged into the melting furnace and the metal is “sucked” into the shell by the vacuum (see figure 4.3).

The Mg Castings were produced from the different LM patterns using this IC furnace. These castings were then put through the same measurement programs discussed above for a direct comparison to the actual patterns. This will allow replication, shrinkage etc to be measured from which conclusions can be drawn.

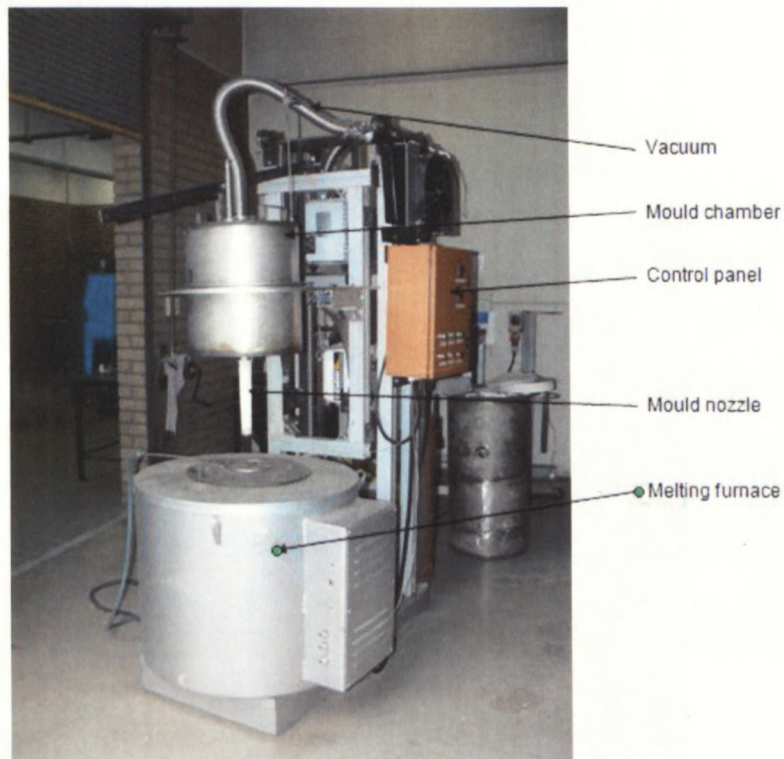

Figure 4.3 Counter gravity Vacuum Furnace

Ti requires a much higher melting and pouring temperature and therefore requires a different type of furnace. Ti is also very reactive when it comes in contact with oxygen and therefore must be done under vacuum. The CSIR modified a vacuum furnace that was initially used for nickel and cobalt based alloys which were cast at approximately 1650°C, where as Ti is cast in the region of 1850°C. Figure 4.4 shows the modified furnace. The same measurement and analysis programs will be used for the Ti castings. All castings were cast at the CSIR casting facility in Pretoria.



**Figure 4.4 Modified Vacuum furnace.**

## 5. CASE STUDY- HYDRODYNAMIC TORQUE CONVERTOR IMPELLER

During the course of the research a commercial project from a Polish company, Huta Stalowa Wola S.A, was given to the Rapid Product Development Labs (RPDL) at Stellenbosch University to develop a strategy for the manufacture of hydrodynamic torque converter impellers. The RPDL was tasked with four different impellers, ranging in size from 150mm to 500mm diameters (figure 5.1). For illustrative and experimental purposes, only the largest impeller Pump 440-01 (diameter 500mm) will be discussed in this section.

The approach and methodology discussed in section 4.4 has been applied to the analysis of the effectiveness of utilizing RP for IC of large components.

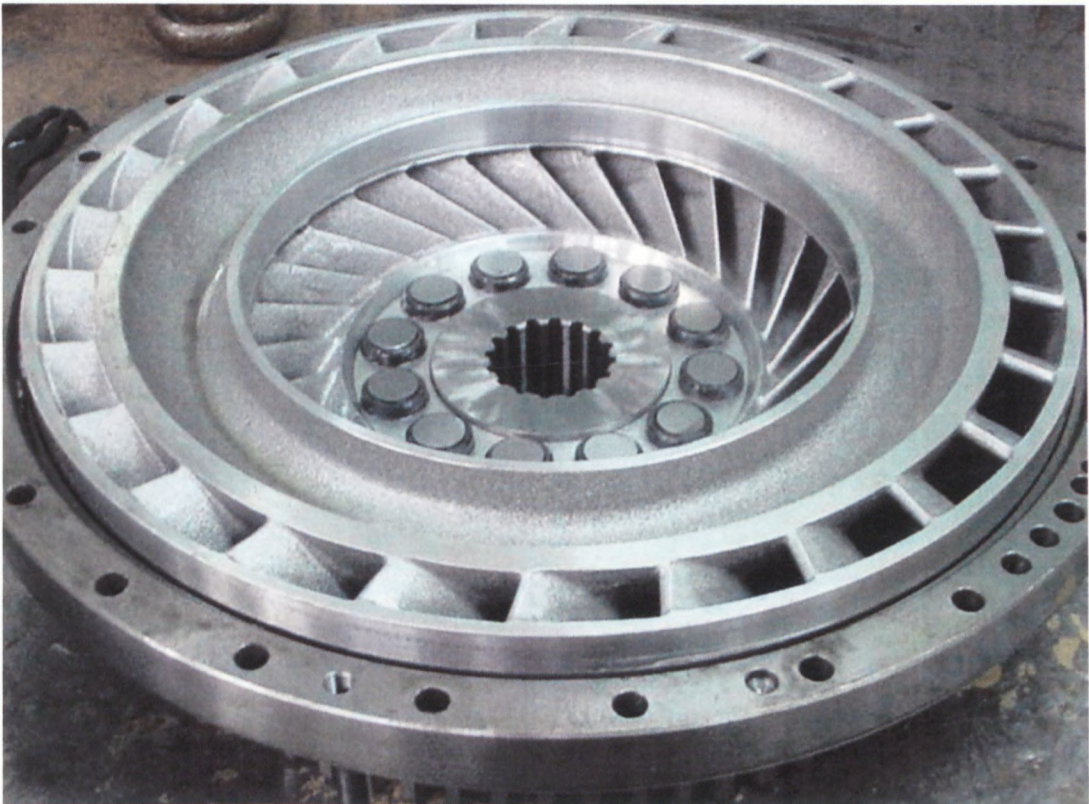

Figure 5.1 Hydrodynamic Torque Converter Impeller

## 5.1. PATTERN CREATION AND PREPARATION

The pattern was built on the EOS P380, a Selective Laser Sintering (SLS) machine in polystyrene (primecast). The component had a diameter of 534 mm and a height of 149 mm. The part was split into two halves in order to accommodate the building envelope of the EOS machine (Figure 5.2).

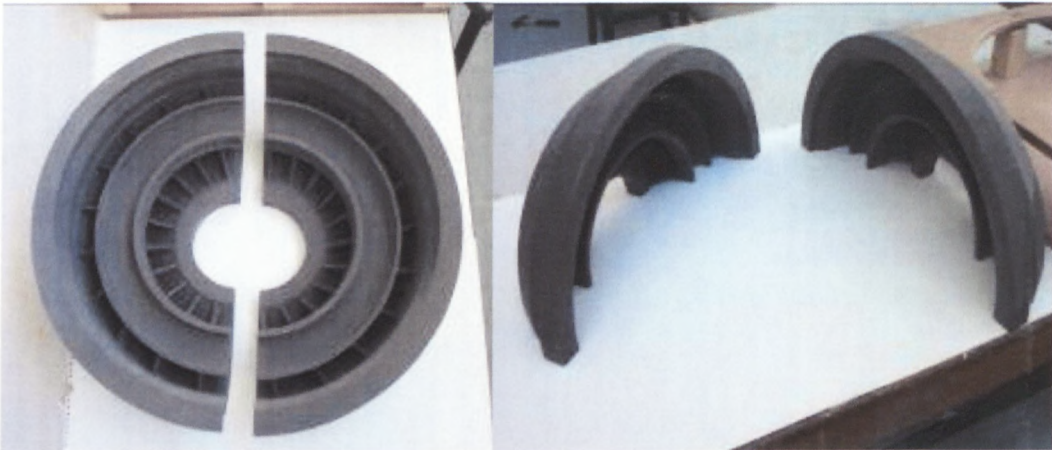

Figure 5.2 Split Pattern

Both halves were infiltrated with a mixture of microcrystalline wax and paraffin wax. The pattern is fragile and had to be handled with care at all times (figure 5.3). After infiltration the pattern was placed in a 70 °C oven to remove excess wax.



Figure 5.3 Wax Infiltration of Pattern

A jig was built to ensure that the two halves line-up perfectly before joining/ gluing. The two halves are placed in the jig, aligned and then clamped to make sure that the alignment stays perfect (figure 5.4).

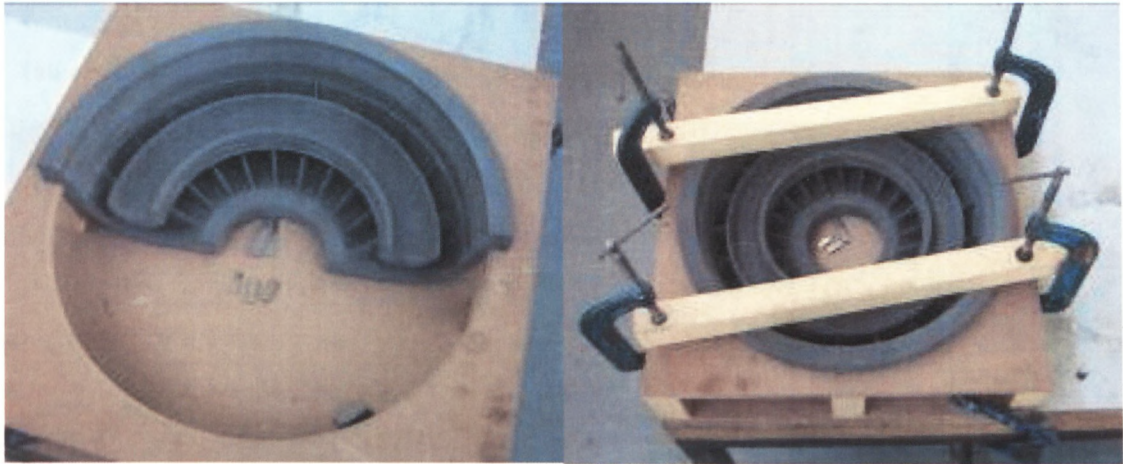

**Figure 5.4 Jig Used for Assembly of Two Halves**

After joining/gluing the halves together all gaps are filled with wax (figure 5.5). The wax-filled gaps are post finished for conformity to the pattern specification.

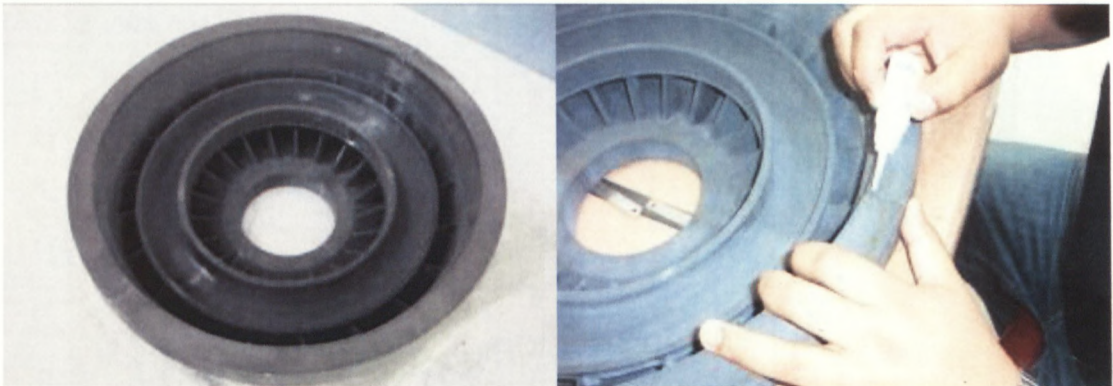

**Figure 5.5 Assemblies and Finishing of Pattern**

## 5.2. RAPID PATTERN - EVALUATION RESULTS AND DISCUSSION

### 5.2.1. STATISTICAL OBSERVATIONS

The following observations were made:

- Visual inspection signifies a good pattern with high definition (figure 5.6).
- Statistical analysis was made by creating the Error Distribution Function (EDF) and the list of descriptive statistics.
- The histogram and median clearly indicate that the error distribution is generally centered around zero, indicating that the errors are random and not systematic.
- A small standard error of 0.0203 indicates that the sample size used is sufficient to support the results with good confidence. Sampling fluctuation is therefore small for these statistics.
- Skewness has a positive value of 0.7484 for the pattern meaning that the distribution has a longer tail to the right.
- The pattern has a kurtosis value of 1.187; because it is lower than 3, the distribution is considered platykurtic. This indicates that the distribution has a low peak and flat midrange. The largest and smallest measured values are 1.1648 mm and -0.883 mm respectively.

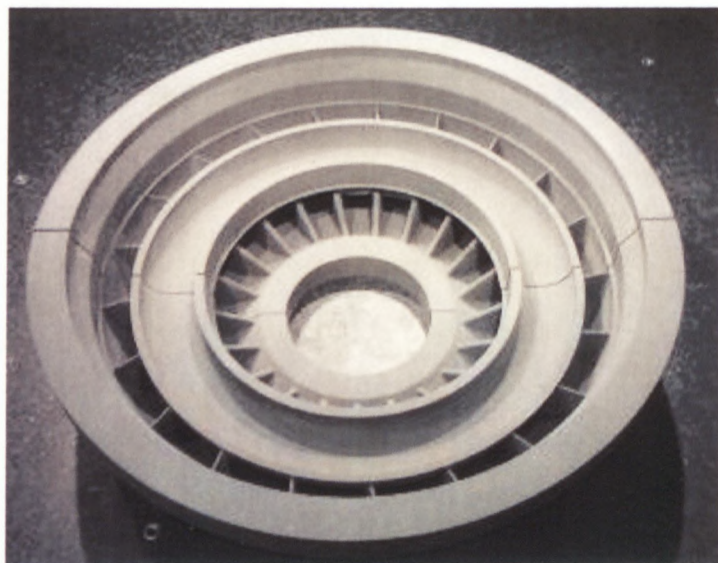
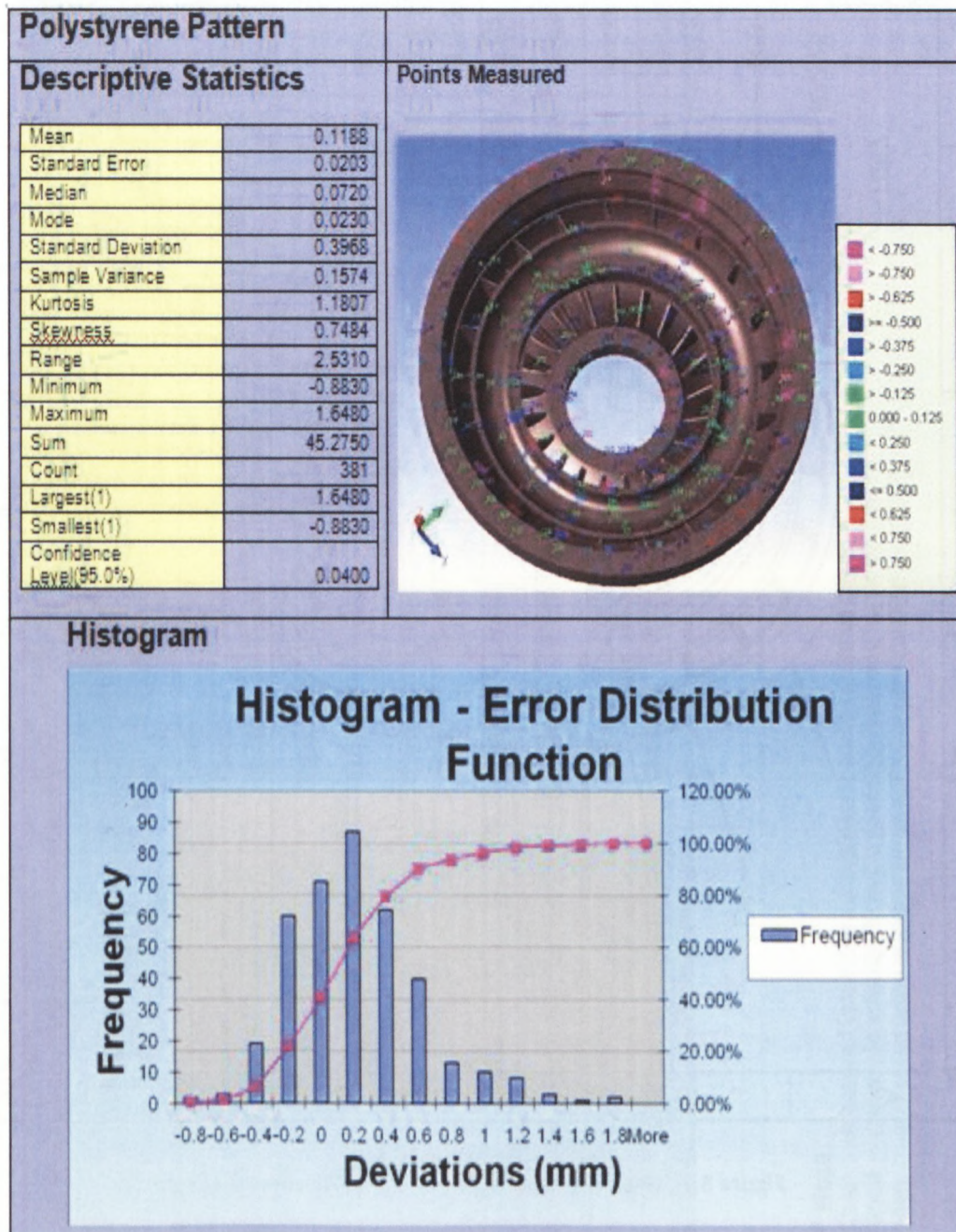

**Figure 5.6 Polystyrene Pattern**

The pattern presents good overall statistical accuracy with a mean of 0.1188 mm. The largest and smallest values measured are 1.648 mm and -0.883 mm respectively. Figure 5.7 illustrates the

features measured for geometric and dimensional assessment. Table 5.1 below depicts the descriptive statistics and error distribution of the pattern. Results of the measured tolerances are shown in table 5.2 on page 65. The full dimensional analysis results can be found in on page 329 in appendix K and L in the appendices section.

Table 5.1 Descriptive Statistics – Pattern (Pump 440-01)



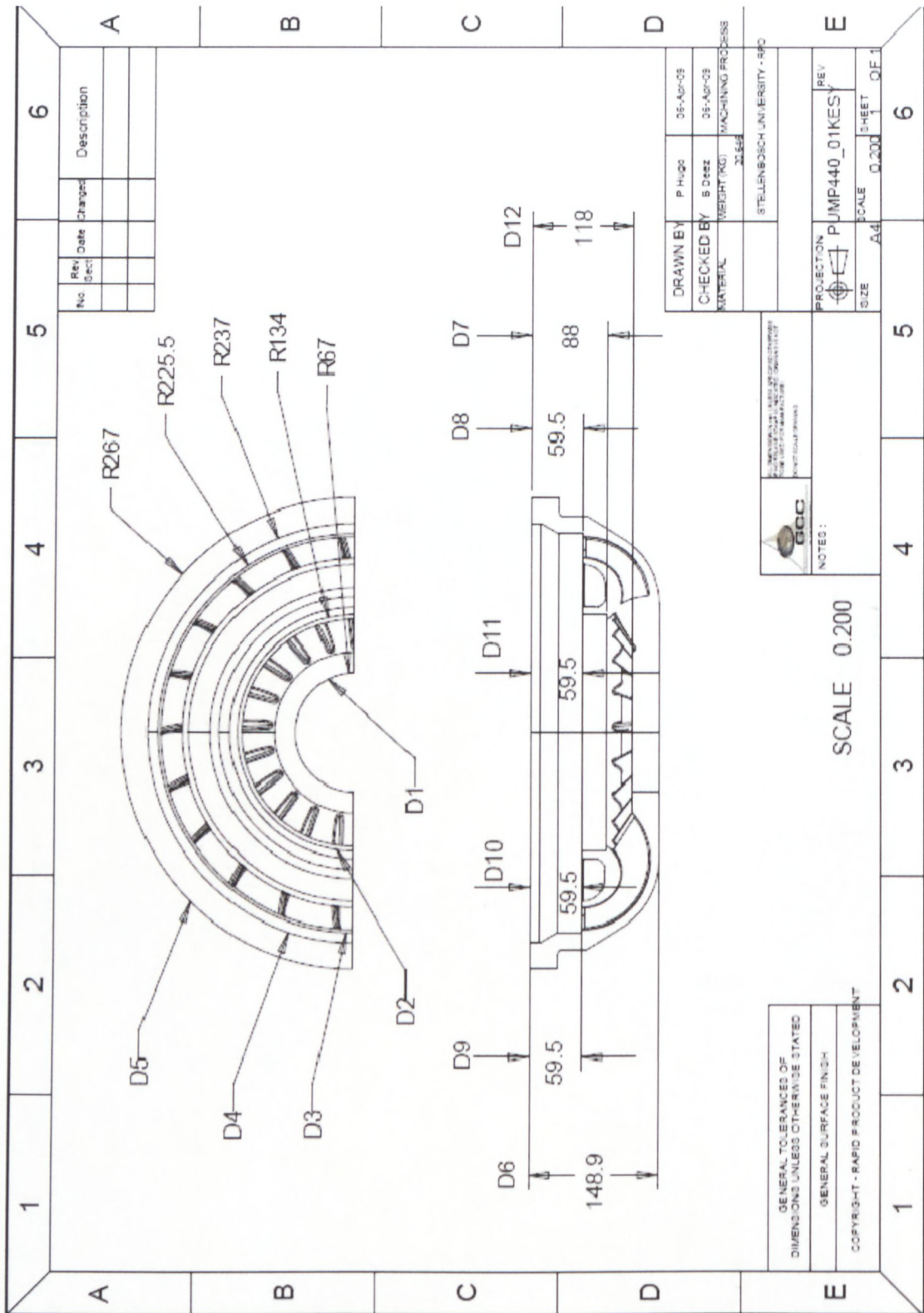

Figure 5.7 Geometrical and Dimensional Features measured

Table 5.2 Dimensional Observations – Pattern (Pump 440-01)

Feature Tolerances - Pump440_01Key											
Tolerance No.	Feature	TolElem Name	Compared to	Type of Tolerance	Spec.	Lower Tol.	Upper Tol.	Actual	Tol. Deviation	Result	
D1	CenterCircle1 Mean	Circle	Point	Diameter	135.34	-1.000	1.000	135.379	0.039	Good	
D2	CenterCircle2 Mean	Circle	Point	Diameter	270.68	-1.000	1.000	270.406	-0.274	Good	
D3	CenterCircle3 Mean	Circle	Point	Diameter	455.51	-1.000	1.000	454.784	-0.726	Good	
D4	CenterCircle4_Inner Mean	Circle	Point	Diameter	478.74	-1.000	1.000	477.613	-1.127	Low	
D5	CenterCircle5_Outer Mean	Circle	Point	Diameter	539.34	-1.000	1.000	538.641	-0.699	Good	
D6	Top to Point1_Table no compensation	Circle	Point	Distance	150.39	-1.000	1.000	150.003	-0.386	Good	
D7	Top to Point2_Step2 no compensation	Circle	Point	Distance	88.88	-1.000	1.000	88.161	-0.719	Good	
D8	Top to Point2_Step3a no compensation	Circle	Point	Distance	60.10	-1.000	1.000	59.333	-0.762	Good	
D9	Top to Point2_Step3b no compensation	Circle	Point	Distance	60.10	-1.000	1.000	59.076	-1.019	Low	
D10	Top to Point2_Step3c no compensation	Circle	Point	Distance	60.10	-1.000	1.000	58.898	-1.197	Low	
D11	Top Plane to Upper Line	Circle	Point	Distance	60.10	-1.000	1.000	60.259	0.164	Good	
D12	Top to Point2_Step1 no compensation	Circle	Point	Distance	119.18	-1.000	1.000	118.508	-0.672	Good	

**\* Note**

- Low - measured value is lower than the specified lower tolerance
- Good - measured value is within the specified lower and upper tolerance
- High - measured value is above the specified upper tolerance

For such a large rapid prototyped part the pattern is quite accurate, the highest deviation being -1.197mm for measurement D10. D1 to D5 indicates that the pattern has good geometric accuracy in terms of the circular measurements, the highest being -1.127mm over a distance of nearly a half meter for D4.

A Mitutoyo Surftest 211 was used to take surface measurements. The machine drags a probe over a pre-determined distance on the surface, namely the cut-off-length. Ten random measurements were taken in the x, y and z directions and averaged to obtain the overall roughness for the pattern. *Ra* was selected as the roughness parameter to be measured and a cut-off-length of 0.8mm used.

**Table 5.3 Patterns Surface Roughness**

Surface Roughness	x	y	z	Pattern (avg.)
<b>SLS Pattern</b>	<i>Ra</i> ( $\mu\text{m}$ )	<i>Ra</i> ( $\mu\text{m}$ )	<i>Ra</i> ( $\mu\text{m}$ )	<i>Ra</i> ( $\mu\text{m}$ )
<b>1</b>	13.50	21.74	24.14	19.79
<b>2</b>	14.63	21.84	18.79	18.42
<b>3</b>	22.56	20.31	20.43	21.10
<b>4</b>	20.52	20.34	23.19	21.35
<b>5</b>	23.51	19.26	19.42	20.73
<b>6</b>	21.57	19.83	20.83	20.74
<b>7</b>	21.71	24.14	20.17	22.01
<b>8</b>	23.10	25.12	24.30	24.17
<b>9</b>	20.31	22.81	21.33	21.48
<b>10</b>	26.31	22.27	21.71	23.43
<b>(avg.)</b>	<b>20.77</b>	<b>21.77</b>	<b>21.43</b>	<b>21.32</b>

The surface finish results indicate, as shown in Table 5.3, that the pattern has a *Ra* average value of 21.32  $\mu\text{m}$ . This value is slightly high but in this case is acceptable.

### 5.3. CASTING - EVALUATION RESULTS AND DISCUSSION

#### 5.3.1. STATISTICAL OBSERVATIONS

Figure 5.8 shows the casting produced from the SLS pattern. Observations were made from the EDF (Error Distribution Function) and list the descriptive statistics below. The histogram and median (Table 5.4) show that the error distribution is generally centered around zero, and indicates the errors are random and not systematic.

A small standard error of 0.0102 indicates that the sample size used is sufficient to support the results with good confidence. Sampling fluctuation is therefore small for these statistics.

The pattern has a kurtosis value of 1.1807; because it is lower than 3, the distribution is considered platykurtic. This indicates that the distribution has a low peak and flat midrange. The largest and smallest measured values are 0.8240 mm and -0.4415 mm respectively.

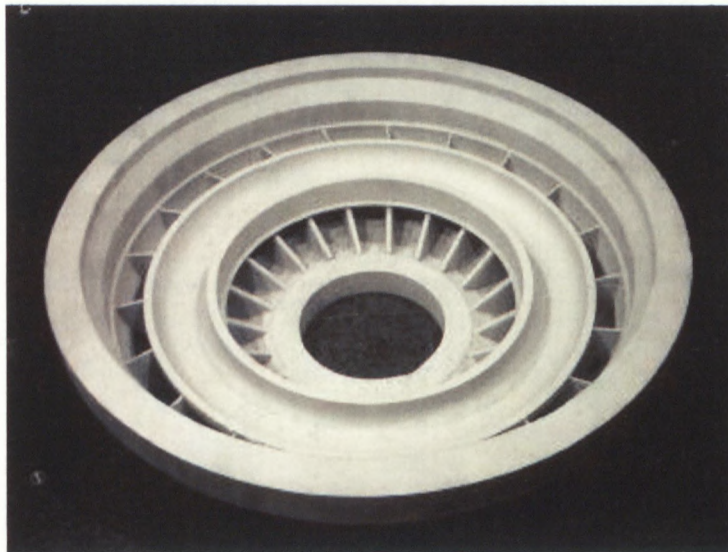

**Figure 5.8 Pump 440-01– Aluminium Casting**

Table 5.4 depicts the descriptive statistics and error distribution of the casting. The measured results are shown in table 5.5. The casting statistical measurements indicate a mean of 0.0594mm. That means that statistically the overall casting (overall process) is accurate.

### 5.3.2. SHRINKAGE

The shrinkage calculation was done by using the following formula:

$$\%Shrinkage = \frac{PatternMeasurement - CastingMeasurement}{CastingMeasurement} \times 100$$

The component's large size allows for an accurate and reliable calculation. A value of 0.92 % was obtained which is close to the industry norm of 1 %. A total of 381 measurements were used for calculation above.

**Table 5.4** Descriptive Statistics – Casting (Pump 440-01)

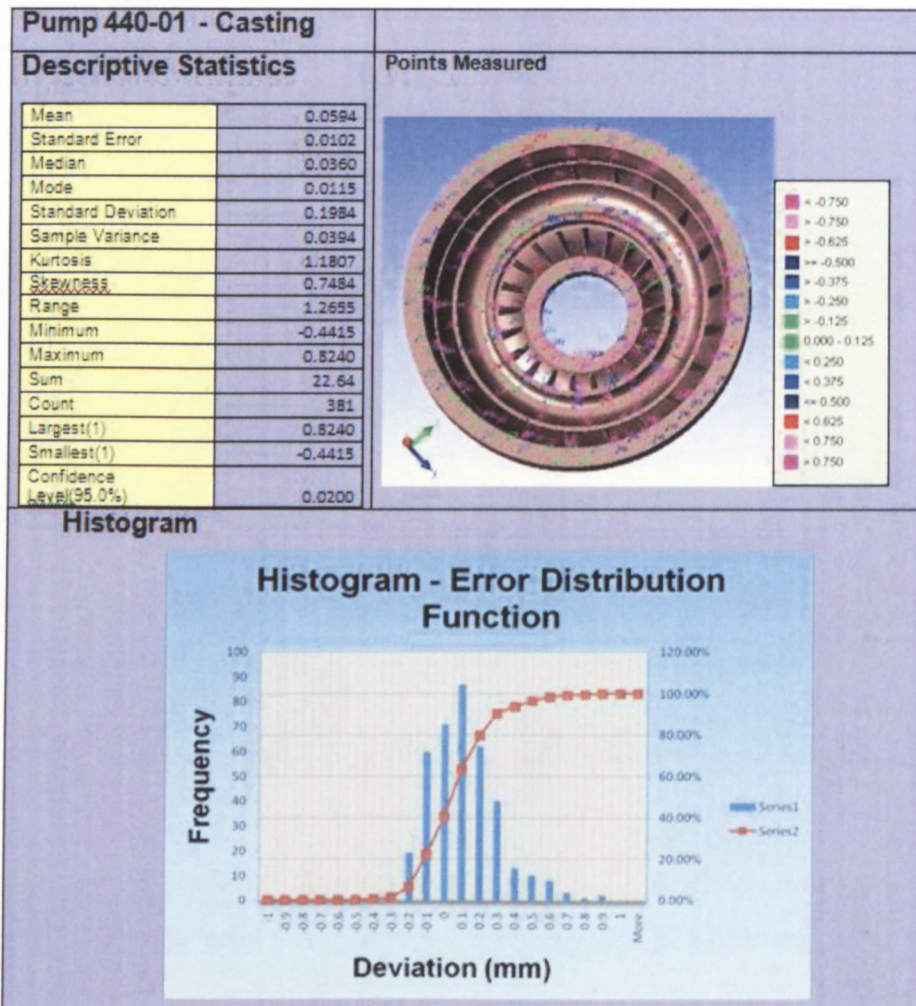

Table 5.5 Dimensional Observations – Casting (Pump 440-01)

Feature Tolerances - Pump440_01Kesey											
Tolerance No.	Feature	Tol.ElemName	Compared to	Type of Tolerance	Spec.	Lower Tol.	Upper Tol.	Actual	Tol. Deviation	Result	
D1	CenterCircle1 Mean	Circle	Point	Diameter	134.00	-1.000	1.000	134.705	0.705	Good	
D2	CenterCircle2 Mean	Circle	Point	Diameter	268.00	-1.000	1.000	268.26	0.261	Good	
D3	CenterCircle3 Mean	Circle	Point	Diameter	451.00	-1.000	1.000	450.955	-0.045	Good	
D4	CenterCircle4_Inner Mean	Circle	Point	Diameter	474.00	-1.000	1.000	473.532	-0.468	Good	
D5	CenterCircle5_Outer Mean	Circle	Point	Diameter	534.00	-1.000	1.000	533.190	-0.810	Good	
D6	Top to Point1_Table no compensation	Circle	Point	Distance	148.90	-1.000	1.000	148.843	-0.057	Good	
D7	Top to Point2_Step2 ro	Circle	Point	Distance	88.00	-1.000	1.000	87.221	-0.779	Good	
D8	Top to Point2_Step3a ro compensation	Circle	Point	Distance	59.50	-1.000	1.000	58.711	-0.789	Good	
D9	Top to Point2_Step3b ro compensation	Circle	Point	Distance	59.50	-1.000	1.000	58.291	-1.209	Low	
D10	Top to Point2_Step3c ro compensation	Circle	Point	Distance	59.50	-1.000	1.000	58.309	-1.191	Low	
D11	Top Plane to Upper Line	Circle	Point	Distance	59.50	-1.000	1.000	60.782	1.282	High	
D12	Top to Point2_Step1 ro compensation	Circle	Point	Distance	118.00	-1.000	1.000	119.697	1.697	High	

Table 6 Geometric Observations – Casting (Pump 440-01)

**\* Note**

- Low - measured value is lower than the specified lower tolerance
- Good - measured value is within the specified lower and upper tolerance
- High - measured value is above the specified upper tolerance

### 5.3.3. RESULTS DISCUSSION

Figure 5.7 on page 64, illustrates the features measured for geometric assessment. Geometrically the casting conforms to the required tolerance, the highest deviation being 1.697mm for measurement D12. The reason for this value being high relative to other points is due to the shrinkage behaviour of the casting because of the varying wall thicknesses and the inherent processing conditions of investment casting.

D1 to D5 indicates that the pattern has reasonable geometric accuracy in terms of the circular measurements, the highest being -0.810 mm over a distance of more than 500mm for D5. Certain areas of the casting show good surface finish, however the porosity of the casting gives a bad overall surface finish.

### 5.3.4. OBSERVATIONS

From the casting it is obvious that there are a number of issues needing improvement. Porosity and shrinkage are the most visible problems.

The weight of the pattern (11 Kg) is the main and foremost issue that brought forth numerous processing problems. During the preparation of feeders and gates, these areas would break as soon as it was to be prepared for the shell process.

After a number of unsuccessful attempts to construct the wax tree, the shell was finally obtained and readied for casting. As shown in figure 5.9 and 5.10, the casting is porosity ridden which is process (casting) and design related. This could be reduced and avoided to an acceptable level by conducting casting simulation analysis such as Magmaflow, Procast etc.

The foundry company has also indicated that sand casting might be a better option for this specific component, however there are concerns regarding this process as well and the process will most likely also have to be taken through a development process in order to achieve the required results. The final casting weighed 19 kg.

As mentioned earlier the pattern was made available within a week including the assembly procedure. The development of the casting process itself however took months. To a certain

extent this is a result of the holiday season (December – January), during which period most of the SA manufacturing companies shut down. This being a “research/commercial” project also added time delays as this type of work usually takes a back seat to production jobs. However the complexity, size and weight of the component caused technical issues as it was difficult to keep the wax tree in its entirety. Various ways to build the tree were explored until success was achieved. The actual casting process was also complex and time consuming, primarily due the weight issue – approximately 20 kg pattern and shell, 21 kg metal. Figure 5.9 shows the porosity areas.



**Figure 5.9 Porosity shown in Casting**

Fractures are visible at the inlet vanes. Cracks are most likely caused by shrinkage,

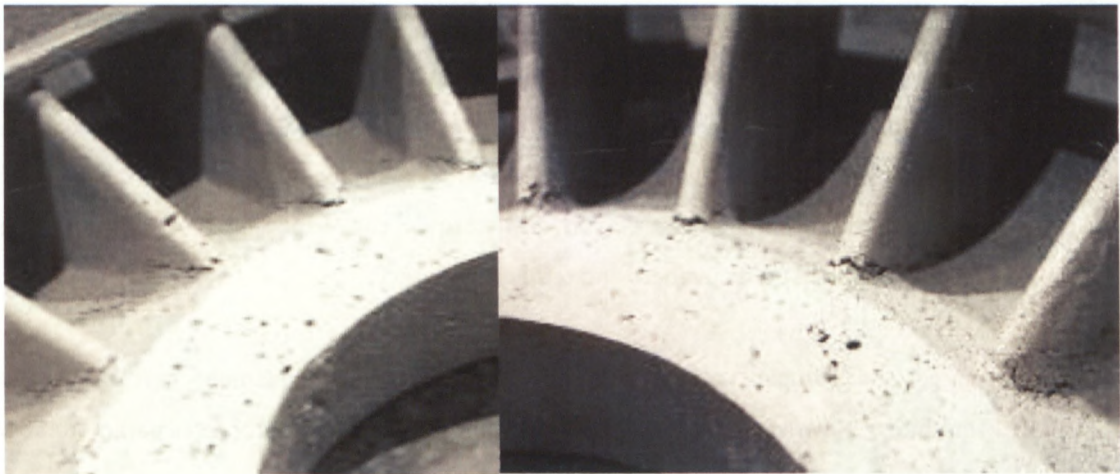

**Figure 5.10 Crack formation**

Porosity can also be observed where the runners were cut off as seen in figure 5.11 below.

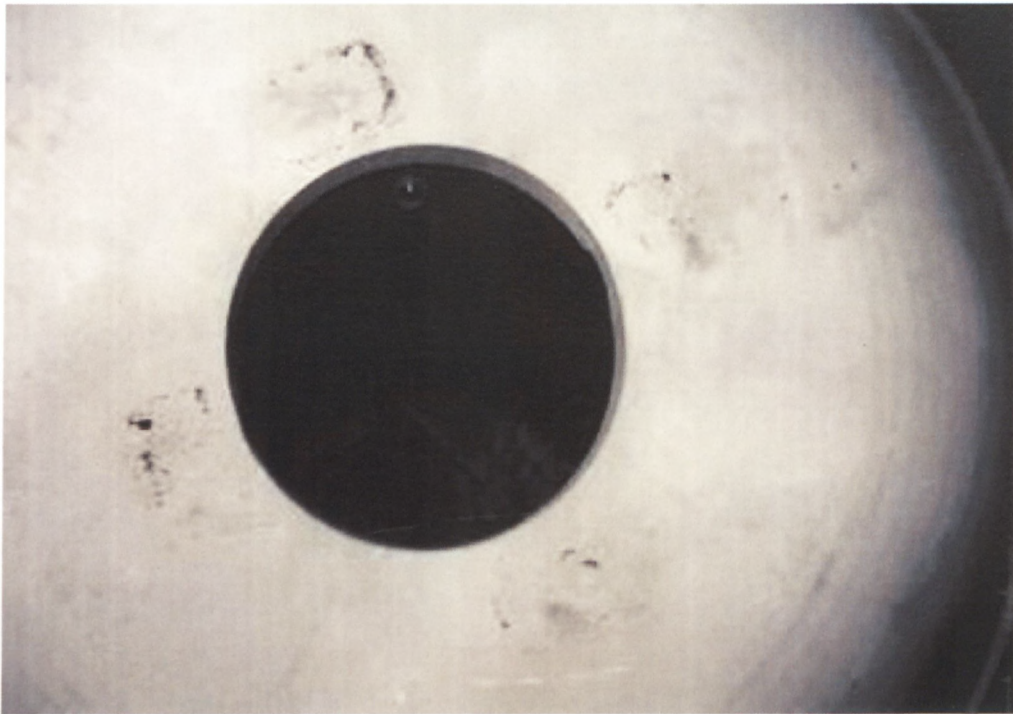

Figure 5.11 Porosity at gates

#### 5.4. CONCLUSIONS AND RECOMMENDATIONS

Based on the observations and analysis the following conclusions can be drawn:

1. The rapid pattern making process for investment casting using layer manufacturing technologies and laser sintering in particular, can be successfully applied for large components as demonstrated on the torque convertor impellor with regards to productivity, cost effectiveness and required accuracy.
2. Large and complex components can be successfully investment cast using additive methods. However, the wall thickness and overall geometry are parameters which determine the success of the process to a large extent.

3. This particular component has complex geometry and a various wall thicknesses, which makes the metal solidification process difficult with substantial differences in the shrinkage behaviour, resulting in porosity and cracks/tearing. In addition the large size and heavy weight both of pattern/shell, as well as metal (actual casting) make the handling of the process – preparation, melting, metal pouring and cleaning – extremely labour intensive, time consuming, difficult and risky.
4. Although dimensionally and geometrically within the required tolerance, the mechanical properties, i.e. strength, elongation and other, of the casting are questionable. This needs a proper investigation before being put under load conditions. If used for efficiency studies from a design and geometric point of view, then the achieved result should be acceptable.
5. This project clearly shows the advantage of modelling and simulation of the casting process. Through analysis, an optimised design and foundry process can be achieved, avoiding castings defects and improved mechanical properties. Design for Manufacturability principles could be implemented more effectively.
6. The investment casting process might not be the ideal process for this specific component. The results and lessons learnt from the first run should be used to develop a better methodology and the component should be cast again to validate the first statement.
7. The sand casting process could be more suitable in this case and should be investigated as an alternative process.

## 6. DISCUSSION AND ANALYSIS OF EXPERIMENTAL RESULTS

The patterns and dies produced from the selected LM processes were investigated and are summarized in table 6.1 as follows:

Table 6.1 LM processes used for experimentation

LM Process	Pattern	Die	No. of Patterns
3DP(Zcorp)	x		4
LS ( EOS P380)	x		4
ThermoJet	x		4
Polyamide(EOS P380)		x	4
Alumide (EOS P380)		x	4

### LM Patterns

As shown in the above table, four patterns from each LM process was built (figure 6.1 shows the different LM patterns). A total number of four patterns were used as three materials were IC: Aluminium (Al), Magnesium (Mg) and Titanium (Ti). An extra piece/pattern from each process was built as a back-up in the event of pattern breakage or loss during the IC process, which is not uncommon.

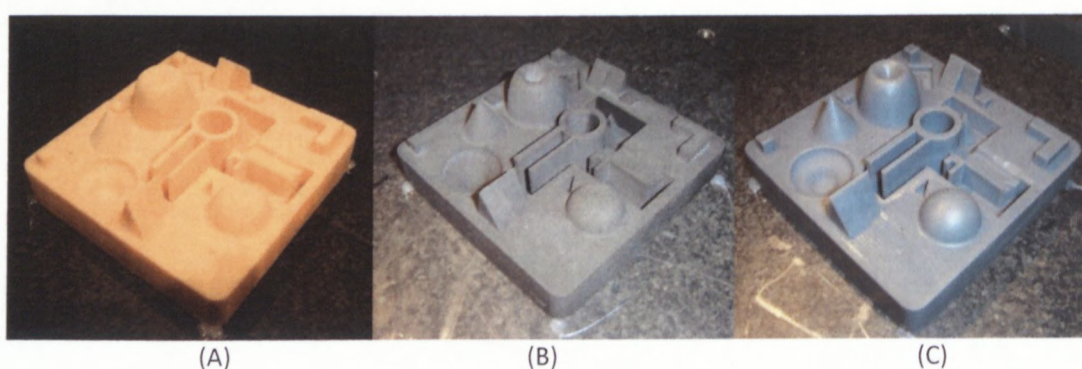

Figure 6.1 3DP- Zcorp (A), LS- EOS (B) and ThermoJet (C)

## LM Dies

Two types of dies were built in Polyamide and Alumide material on the EOS P380 machine as shown in figures 6.2 and 6.3.

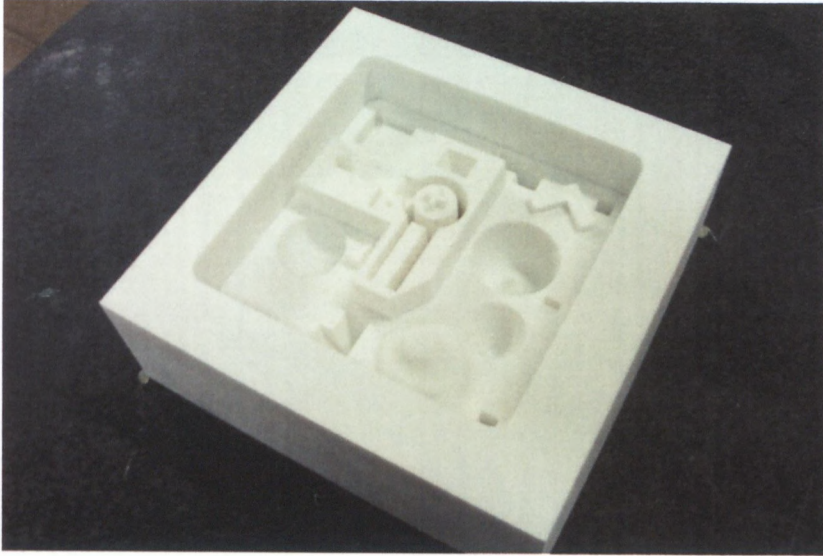

Figure 6.2 Polyamide Cavity

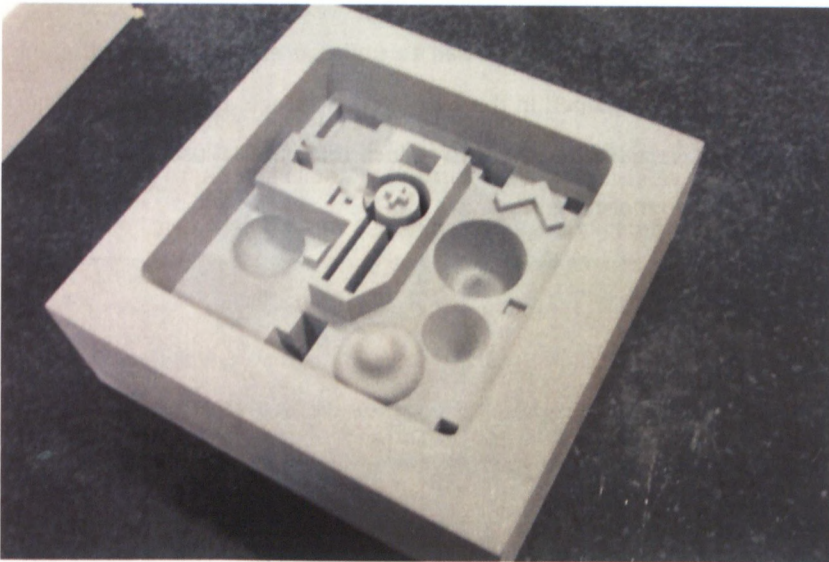
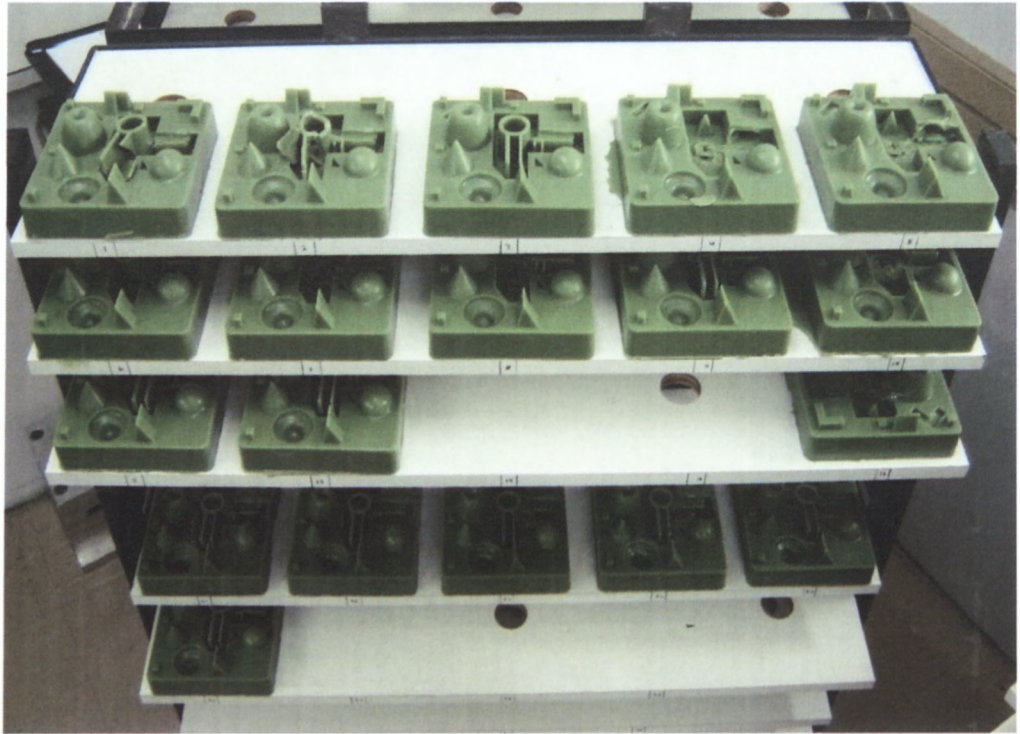

Figure 6.3 Polyamide Cavity

Several wax injected patterns we made as seen in figure 6.4 below, however only the four best were selected for the IC process.



**Figure 6.4 Wax injected Patterns from LM Dies**

Before wax injection was done the dies had to undergo extensive strengthening to be able to withstand the pressures developed in the wax injection stage. LM parts are generally fragile and to save costs the dies were hollowed out to reduce the material usage in the LM building phase. This made the parts even more fragile.

The built dies were then strengthened by filling the hollowed out sections with polyurethane resin for re-inforcement. To add extra strength, an aluminium frame was built around each die which would absorb most of the force needed to keep the dies closed when the wax was injected into them. Figure 6.5 below summarizes this strengthening process.

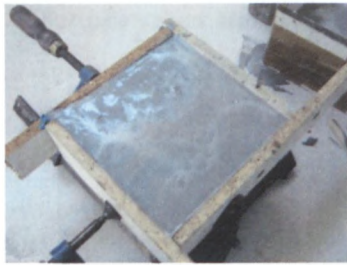

a. F18 Resin Filling

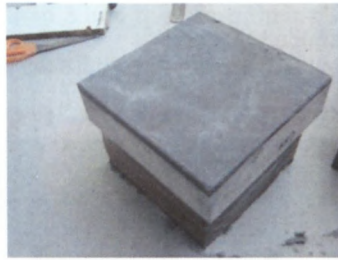

b. Polyamide Core Filled

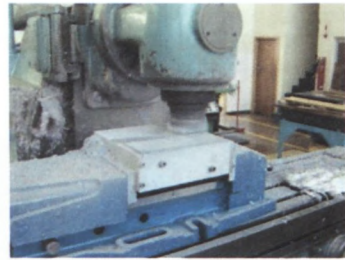

c. Face Machining of the underside

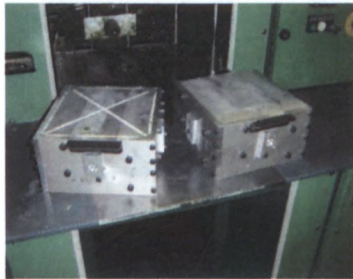

d. Closed Reinforced Dies



e. Opened Reinforced Dies



f. Injection Point

Figure 6.5 Re-inforced Polyamide and Alumide Dies

The following section will discuss the castings obtained using these three materials, manufactured from the above mentioned patterns.

### 6.1. ALUMINIUM CASTINGS

All five castings had small inclusions that caused surface defects. Figure 6.6 shows the three castings, cast from Layer Manufactured (LM) patterns as indicated.

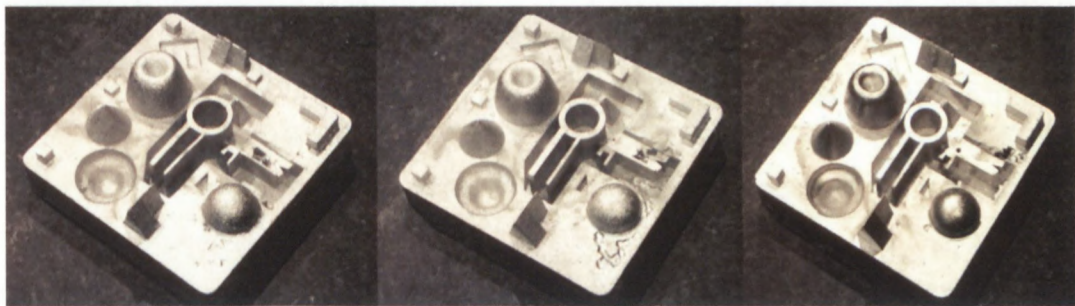

(A)

(B)

(C)

Figure 6.6 Aluminium Castings from LM Patterns -3DP- Zcorp (A), LS- EOS (B) and ThermoJet (C)

The two castings shown in figure 6.7 below were cast from the wax injected patterns produced from the Alumide and the Polyamide LM dies.

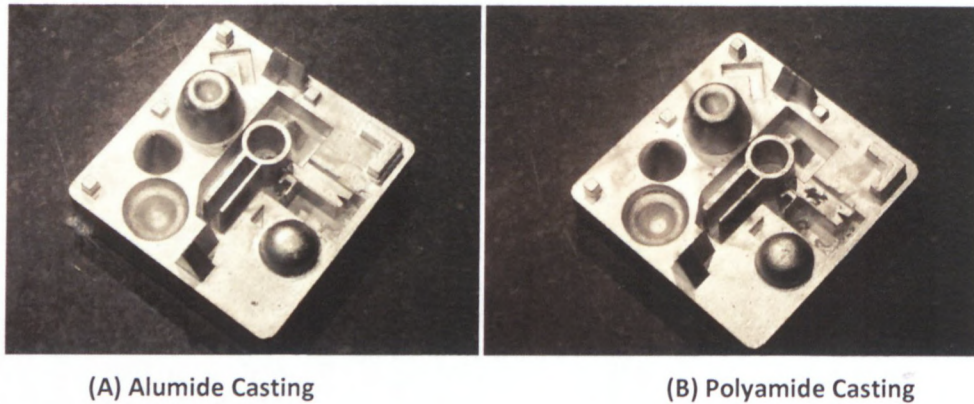

Figure 6.7 Aluminium Castings from Alumide and Polyamide Die Wax Patterns

Each of the castings was measured on the Coordinate Measuring Machine (CMM) using the same programs as previously discussed and the data obtained was analysed.

## 6.2. EVALUATION AND DISCUSSION OF RESULTS - ALUMINIUM CASTINGS

### 6.2.1. STATISTICAL OBSERVATIONS

The histograms and medians indicate that the error distributions are generally centered around 0.33 mm. All histograms have a resemblance to a close-to-normal-shape, see Appendix D.

Confidence intervals are constructed using standard errors. All castings have small standard errors indicating that the sample size used is sufficient to support the results with good confidence.

Skewness show positive values for all five castings, which means that the distributions are hanging over to the left.

Kurtosis values are all higher than 3 and therefore their distributions are considered Leptokurtic. Leptokurtic indicates that the distributions have high peaks, thin midranges and fat tails. The largest and smallest measured values average at 1.731 mm and 0.038 mm respectively for the castings.

The confidence level is a quick method to compare the accuracy of the five parts. For example, the errors of the 3DP casting will have a mean deviation of  $0.3281 \pm 0.0157$  mm. The small values for all castings indicate that all parts have good accuracy.

The statistical calculations are compared in table 6.2. All statistical data can be found in the Appendix C

**Table 6.2 Aluminium Castings Statistics**

Statistics	Aluminium Castings				
	3DP	LS	ThermoJet	Alumide Die	Polyamide Die
Mean	0.3281	0.3327	0.3284	0.3609	0.3321
Standard Error	0.0080	0.0069	0.0064	0.0094	0.0105
Median	0.3075	0.3224	0.3113	0.3302	0.2990
Mode	#N/A	#N/A	#N/A	#N/A	#N/A
Standard Deviation	0.1826	0.1580	0.1455	0.2139	0.2401
Sample Variance	0.0333	0.0250	0.0212	0.0457	0.0577
Kurtosis	8.4923	11.3416	4.5809	15.1471	23.7007
Skewness	2.1430	2.1011	1.4313	3.1183	3.9168
Range	1.4826	1.5751	1.0562	1.8800	2.4699
Minimum	0.0207	0.0718	0.0401	0.0195	0.0397
Maximum	1.5033	1.6470	1.0963	1.8995	2.5095
Sum	171.27	173.99	171.76	188.75	173.68
Count	522	523	523	523	523
Largest(1)	1.5033	1.6470	1.0963	1.8995	2.5095
Smallest(1)	0.0207	0.0718	0.0401	0.0195	0.0397
Confidence Level (95.0%)	0.0157	0.0136	0.0125	0.0184	0.0206

### 6.2.2. ALUMINIUM SHRINKAGE VALUE

The largest dimensional measurements were used to calculate the shrinkage value for each casting. Small values were discarded. The small measurements are more prone to warpage and surface roughness, which then gives out-shooters in the data. Shrinkage is determined by comparing the casting and pattern measurements:

$$\%Shrinkage = \frac{PatternMeasurement - CastingMeasurement}{CastingMeasurement} \times 100$$

The average shrinkage value calculated was 0.53%, table 6.3. Most foundries work with a value of 1%, indicating that the castings did not shrink as much as would be expected. There are many factors that influence shrinkage, one of these are the many different features on the benchmark part that constrain each other and does not allow full contraction.

**Table 6.3 Shrinkage Value Calculation for Aluminium Castings**

Aluminium Casting	Qty	Shrinkage%
3DP	1	0.25
LS	1	0.57
ThermoJet	1	0.45
Wax from Alumide Die	1	0.59
Wax from Polyamide Die	1	0.77
<b>Avg. Shrinkage for Aluminium:</b>		<b>0.53</b>

As seen in the table above, there are quite large discrepancies between the various casting shrinkage values. The same face coat was used for each LM pattern. The variation could be due to the different reaction between the face coat and various pattern materials.

### 6.2.3. ANALYSIS OF THE BUILT FEATURES (ALUMINIUM CASTINGS FROM LM PATTERNS)

A basic tolerance of  $\pm 0.5$  mm is used for all feature measurements on all castings. See Appendix B for data.

#### Cubes

The cubes were used to check for straightness in the x and y direction, by checking if they were built in a straight line. The highest straightness deviation was 0.264 mm in the x direction for the 3DP casting. All cubes have good definition with only two out of tolerance, E9 with a value of 1.237 mm on the LS casting and A14 with a value of 1.809 mm on the ThermoJet casting.

#### Wedges

All wedges have good dimensions. All wedges have poor angularity in the x and y direction, with the highest value of 1.646 for AA3 on the ThermoJet.

#### Pyramid

Half the angularity values on each casting are out of tolerance, with a highest value of 0.969 on the ThermoJet casting.

#### Cylinder

All castings present good cylindricity and concentricity, all within the  $\pm 0.5$  mm tolerance. Every inner and outer cylinder diameter is within tolerance.

#### Square Base

All castings are larger in the y direction with a highest value of 1.165 mm on the LS casting. The 3DP has poor flatness. Both the LS and ThermoJet castings have one parallelism and perpendicularity measurement out of tolerance.

#### Thin Walls

All thin walls on castings present good thickness dimensions and parallelism, except for the poor parallelism on the 3DP casting with a highest value of 2.603 mm.

#### Rectangular Protrusion/Hole

The rectangular protrusions and rectangular holes present good dimensional and perpendicularity values for all castings, except for poor perpendicularity values on the 3DP casting with a highest value of 1.29 mm

#### Tri-angular Hole

The tri-angular holes on all castings present excellent perpendicularity and depth values, all well within tolerance.

#### Cone

All cones exhibit good angularity and coaxiality. The cones on all castings have good circular runout in terms of circles measured around the cone, when using the actual cone axis. All castings have poor axial runout values.

#### Sphere

All spheres have extremely bad symmetry when using the plane as reference element and high axial runout. All spheres have reasonable circular runout in terms of circles measured around the spheres. All spheres have poor perpendicularity values.

#### Dome

All domes exhibit good circular runouts, symmetry and concentricity, all well within tolerance. However all domes present poor axial runouts. All domes have good perpendicularity except for the 3DP casting with a value of 0.721 mm.

#### Sinkhole

All castings present good circular runouts, symmetry, perpendicularity and concentricity, except for poor perpendicularity by the 3DP and ThermoJet casting. The 3DP casting also presents poor concentricity.

The Dimensional Accuracy Index (DAI) based on the features and tolerances measured, indicates that the LS casting had the best accuracy with a value of 83.65% shown in table 6.4(between

castings from LM patterns). Visual inspection of castings shows that the LS casting has the best definition and reproduction of features as well.

Table 6.4 DAI of Aluminium Castings

DAI – Aluminum Castings					Dimensional Accuracy (DAI) index = Good/Total x 100%
High	X > 0.5				
Good	-0.5 < X > 0.5				
Low	X < -0.5				
Pattern Model	Counts				
	High	Good	Low	Total	
3DP	28	73	3	104	70.19%
LS	14	87	3	104	83.65%
ThermoJet	18	83	3	104	79.81%
Wax Alumide Die	19	82	3	104	78.85%
Wax Polyamide Die	14	89	1	104	81.58%

#### 6.2.4. ANALYSIS OF THE BUILT FEATURES (ALUMINIUM CASTINGS FROM DIE WAX PATTERNS)

A basic tolerance of  $\pm 0.5$  mm is used for all feature measurements on all castings. See Appendix A for data.

##### Cubes

All cubes look good with only one out of tolerance deviation namely A14 with a value of 1.026 mm on the Polyamide casting. Both castings present good straightness values in the x and y directions.

##### Wedges

All wedges have good dimensions. All wedges have poor angularity in the x and y direction, with a highest value of -2.392 mm for AA2 on the Alumide casting.

### Pyramid

Both castings present good angularity with only one out of tolerance value on each, namely CC2 with a value of -1.520 on the Alumide and DD1 with a value of 0.709 on the Polyamide casting.

### Cylinder

Both castings present good cylindricity and concentricity, all within the  $\pm 0.5$  mm tolerance. Every inner and outer cylinder diameter is within tolerance.

### Square Base

The Alumide casting has poor flatness with a value of 1.735 mm. Both castings have good parallelism and perpendicularity

### Thin Walls

All thin walls on castings present good thickness dimensions and parallelism.

### Rectangular Protrusion/Hole

The rectangular protrusions and rectangular holes present good dimensional and perpendicularity values for all castings, except for one poor perpendicularity values on the Alumide casting with a highest value of 0.736 mm.

### Tri-angular Hole

The tri-angular holes on all castings present excellent perpendicularity and depth values, all well within tolerance.

### Cone

All cones exhibit good angularity, but have poor axial runout values. The Alumide casting presents poor coaxiality.

### Sphere

Both spheres have bad symmetry when using the plane as reference element and high axial runout. The Alumide sphere has bad perpendicularity with a value of 1.347 mm. This value is high and is not acceptable.

### Dome

All domes exhibit good circular runout, symmetry and concentricity, all well within tolerance. However all domes present poor axial runout. The Alumide dome has bad perpendicularity with a value of 0.789 mm.

### Sinkhole

All castings present good circular runout and symmetry but poor perpendicularity. The Alumide casting also presents poor concentricity.

The Polyamide wax pattern produced the most accurate casting with a DAI value of 81.58% (Table 6.4). Visually the Polyamide and Alumide aluminium castings present good definition and reproduction of features.

## 6.2.5. ANOVA ANALYSIS

The following hypothesis is stated to determine whether there is a significant difference between the accuracy of the castings from LM Patterns:

$H_0$  : All mean measurements are equal

$H_1$  : All mean measurements are not equal

The table below provides the results when tested against a 95 % confidence level.

**Table 6.5 Single factor ANOVA Results @ 95% Confidence (Aluminium Castings from LM Patterns)**

Anova: Single Factor						
SUMMARY						
Groups	Count	Sum	Average	Variance		
3DP Al Casting	523	171.2702	0.3275	0.0335		
SLS Al Casting	523	173.9910	0.3327	0.0250		
ThermoJet Al Casting	523	171.7618	0.3284	0.0212		
ANOVA						
Source of Variation	SS	df	MS	F	P-value	F crit
Between Groups	0.0080	2	0.0040	0.1515	0.8594	3.0015
Within Groups	41.5496	1566	0.0265			
Total	41.5576	1568				

The results indicate that the Null hypothesis cannot be accepted. There is still a significant difference between the accuracy of the castings produced from LM Patterns.

The following hypothesis is stated to determine whether there is a significant difference between the accuracy of the castings from Die Wax Patterns:

The table below provides the results when tested against a 95 % confidence level.

**Table 6.6 Single factor ANOVA Results @ 95% Confidence (Aluminium Castings from Die Patterns)**

Anova: Single Factor						
SUMMARY						
Groups	Count	Sum	Average	Variance		
Alumide Al Casting	523	188.7483	0.3609	0.0457		
Polyamide Al Casting	523	173.6779	0.3321	0.0577		
ANOVA						
Source of Variation	SS	df	MS	F	P-value	F crit
Between Groups	0.2171	1	0.2171	4.2004	0.0407	3.8504
Within Groups	53.9671	1044	0.0517			
Total	54.1843	1045				

The results indicate that the Null hypothesis cannot be accepted.

### 6.3. EVALUATION AND DISCUSSION OF RESULTS - MAGNESIUM (MG AZ91D) CASTINGS

Only four castings are discussed in this section as the shell made from the alumide wax injected die, collapsed during the preparation phase hence no casting was obtained. The data is therefore slightly different from the previous section. The data obtained from the castings manufactured out of the LM dies as well the LM patterns have been combined and not separated into comparative tables of only dies and patterns. This was done in order to obtain more significant data from the results. The procedure is otherwise exactly the same as applied in the aluminium casting analysis. The results are discussed below.

The Mg castings showed good results, see figure 6.8 and 6.9.

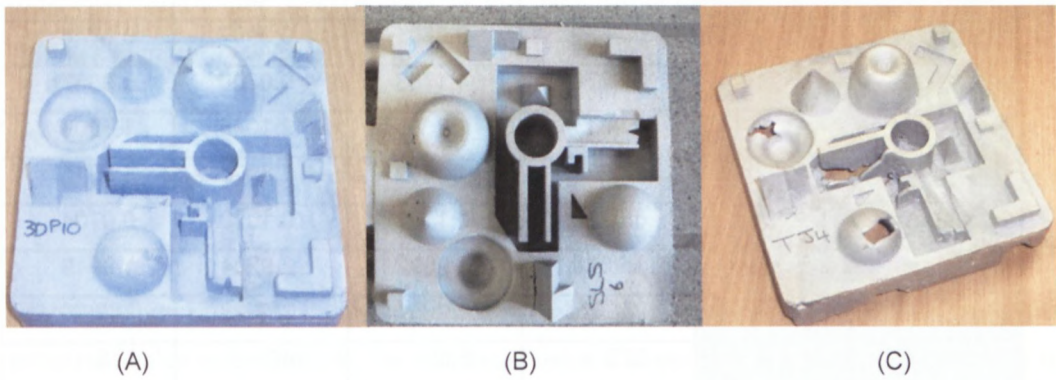

Figure 6.8 Magnesium Castings from LM Patterns -3DP- Zcorp (A), LS- EOS (B) and ThermoJet (C)



Figure 6.9 Magnesium Castings from Polyamide die

### 6.3.1. STATISTICAL OBSERVATIONS

The histograms and medians indicate that the error distributions are generally centered around 0.53 mm. All histograms have a resemblance to a close-to-normal-shape, see Appendix G.

**Table 6.7 Mg Castings Statistics**

<b>Descriptive Statistics</b>	<b>Mg Casting (3DP)</b>	<b>Mg Casting (SLS)</b>	<b>Mg Casting (ThermoJet)</b>	<b>Mg Casting (Polyamide)</b>
Mean	0.4817	0.5516	0.5873	0.5187
Standard Error	0.0103	0.0098	0.0134	0.0120
Median	0.4845	0.5277	0.5268	0.4807
Mode	#N/A	#N/A	#N/A	#N/A
Standard Deviation	0.2349	0.2238	0.3011	0.2728
Sample Variance	0.0552	0.0501	0.0907	0.0744
Kurtosis	3.3278	4.1763	9.0700	5.9007
Skewness	0.9511	1.2589	2.1045	1.8200
Range	1.9624	1.8489	2.8204	1.9215
Minimum	0.0228	0.1103	0.1000	0.0704
Maximum	1.9853	1.9592	2.9204	1.9919
Sum	251.91	288.51	297.18	269.19
Count	523	523	506	519
Largest(1)	1.9853	1.9592	2.9204	1.9919
Smallest(1)	0.0228	0.1103	0.1000	0.0704
Confidence Level (95.0%)	0.0202	0.0192	0.0263	0.0235

Confidence intervals are constructed using standard errors. All castings have small standard errors indicating that the sample size used is sufficient to support the results with good confidence.

Skewness show positive values for all four castings, which means that the distributions are hanging over to the left.

Kurtosis values are all higher than 3 and therefore their distributions are considered Leptokurtic. Leptokurtic indicates that the distributions have high peaks, thin midranges and fat tails. The

largest and smallest measured values average at 9.07 mm and 3.33 mm respectively for the castings.

The confidence level indicates that castings produced from the ThermoJet patterns will have a mean deviation of  $0.5873 \pm 0.0263$  mm. These values indicate the Mg castings had an acceptable accuracy.

### 6.3.2. MAGNESIUM SHRINKAGE VALUE

The largest dimensional measurements were used to calculate the shrinkage value for each casting. Small values were discarded. These are more prone to influenced of warpage and surface roughness, which then gives outliers in the data. Shrinkage is determined by comparing the casting and pattern measurements:

$$\%Shrinkage = \frac{PatternMeasurement - CastingMeasurement}{CastingMeasurement} \times 100$$

Literature shows that Mg shrinkage is between 1-3%, Van Wyk (1992). The table below shows the calculated value to be 0.863 %. The calculated value is lower than the published value, this is due to slight variations in the base material composition as well as small differences in processing parameters i.e. temperature control, vacuum drawn, cooling periods etc.

**Table 6.8 Shrinkage Value for Mg Castings**

Mg Casting	Qty	Shrinkage%
3DP	1	0.85
LS	1	0.78
ThermoJet	1	0.68
Polyamide	1	1.14
<b>Avg. Shrinkage for Magnesium:</b>		0.86 %

### 6.3.3. ANALYSIS OF THE BUILT FEATURES [MAGNESIUM CASTINGS FROM LM PATTERNS AND DIES]

A basic tolerance of  $\pm 0.5$  mm is used for all feature measurements on all castings. See Appendix E for data.

#### Cubes

The cubes were used to check for straightness in the x and y direction. The highest straightness deviation was 0.424 mm in the direction for the Polyamide casting. All cubes measured are within specified tolerance.

#### Wedges

All wedges have good dimensions. All wedges have poor angularity in the x and y direction, with the highest value of 2.472 for BB2 on the 3DP castings.

#### Pyramid

70 % the angularity values on the castings are out of tolerance, with a highest value of 1.8 for CC2 on the 3DP casting.

#### Cylinder

All castings present good cylindricity and concentricity, all within the  $\pm 0.5$  mm tolerance. Every inner and outer cylinder diameter is within the specified tolerance.

#### Square Base

The Polyamide and ThermoJet castings show poor flatness, with the Polyamide having the largest value of 2.017.

#### Thin Walls

All thin walls on castings present good thickness dimensions and parallelism, except for the poor parallelism on the 3DP casting with a highest value of 2.913 mm due to the pattern sagging during the shelling process.

#### Rectangular Protrusion/Hole

The rectangular protrusions and rectangular holes present good dimensional and perpendicularity values for all castings

#### Tri-angular Hole

The tri-angular holes on all castings present excellent perpendicularity and depth values, all well within tolerance.

#### Sphere

All spheres have extremely bad symmetry and high axial runouts when using the plane as reference element. All spheres have poor perpendicularity values.

#### Dome

All domes exhibit good circular runouts, symmetry and concentricity, all well within tolerance

#### Sinkhole

All castings present good circular runouts, symmetry however showed bad perpendicularity and concentricity. The ThermoJet casting showed the worst with a value of 2.609mm.

All measured feature data can be found in the Appendix E.

The Dimensional Accuracy Index (DAI) based on the features and tolerances measured indicates that the LS castings had the best accuracy with a value of 90.74% as shown in table 6.9 below. Visual inspection of castings shows that the LS casting has the best definition and reproduction of features as well.

Table 6.9 DAI of Magnesium Castings

DAI - Magnesium Castings					Dimensional Accuracy index (DAI= Good/Total x 100%)
High	$X > 0.5$				
Good	$-0.5 < X < 0.5$				
Low	$X < -0.5$				
Pattern Model	Counts				
	High	Good	Low	Total	
3DP	16	90	2	108	83.33%
LS	9	98	1	108	90.74%
ThermoJet	13	85	10	108	78.70%
Polyamide	15	69	24	108	63.89%

#### 6.3.4. ANOVA ANALYSIS

The following hypothesis is stated to determine whether there is a significant difference between the accuracy of the castings from LM Patterns and dies:

$H_0$  : All mean measurements are equal

$H_1$  : All mean measurements are not equal

Table 6.10 Single factor ANOVA Results @ 95% Confidence

Anova: Single Factor		Magnesium Castings				
SUMMARY						
Groups	Count	Sum	Average	Variance		
3DP	523	31.991	0.0612	0.0523		
SLS	523	-27.059	-0.0517	0.0277		
ThermoJet	523	-32.991	-0.0631	0.0289		
Polyamide	523	-32.629	-0.0624	0.0643		
ANOVA						
Source of Variation	SS	df	MS	F	P-value	F crit
Between Groups	5.7130	3	1.9043	43.9799	1.48E-27	2.6092
Within Groups	90.4111	2088	0.0433			
Total	96.1241	2091				

Table 6.10 above provides the results when tested against a 95 % confidence level.

The results indicate that the Null hypothesis cannot be accepted. There is still a significant difference between the accuracy of the castings produced from LM Patterns and Wax patterns from Rapid Dies.

#### 6.4. EVALUATION AND DISCUSSION OF RESULTS- TITANIUM (Ti6Al4V) CASTINGS

The type of crucible used to melt the titanium has a substantial effect on the final casting, Beeley, 2001.

Initial Ti casting trials were conducted in 2008 and proved unsuccessful as equipment failure hampered obtaining any useful castings for data extraction. The Ti raw material melted well, however when the crucible fitted with the heating coil assembly was tilted to pour the molten metal into the shell, oxygen and moisture were released. Titanium has a high affinity for hydrogen, oxygen and nitrogen, (Rossouw, 2009). This was caused by the coil coating that could not withstand the high temperatures, resulting in a burnt black coating (figure 6.10) causing a release of oxygen and moisture which embrittled the casting.



a. Damaged Coil

b. Brittle Titanium Casting

c. Oxidation Layer on Casting

**Figure 6.10 Equipment failure**

Modifications were done to the equipment and the casting process resumed in 2009. This attempt proved promising but defects still occurred. All the castings filled well and some of them showed good definition. Gas pores were still visible on the best casting. Based on the results the LS patterns appeared to work the best for the process. Figure 6.11 shows a close-up of the LS pattern casting. The ThermoJet patterns all failed as they reacted with the face coat and collapsed

during the shell production phase. No casting was obtained and based on this result, it was deduced that the ThermoJet patterns were not suitable for the Ti investment casting process.

Some pattern materials used for rapid prototyping work better for titanium than others. There is evidence of the ammonia stabilised face coat showing a slight reaction with some of the patterns, (Rossouw, 2009).

Figure 6.11 and 6.12 show three Ti castings from the different pattern materials.



Figure 6.11 LS Ti casting

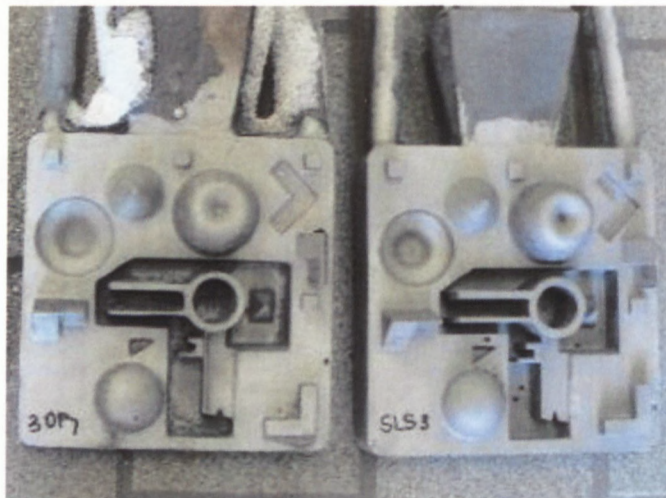
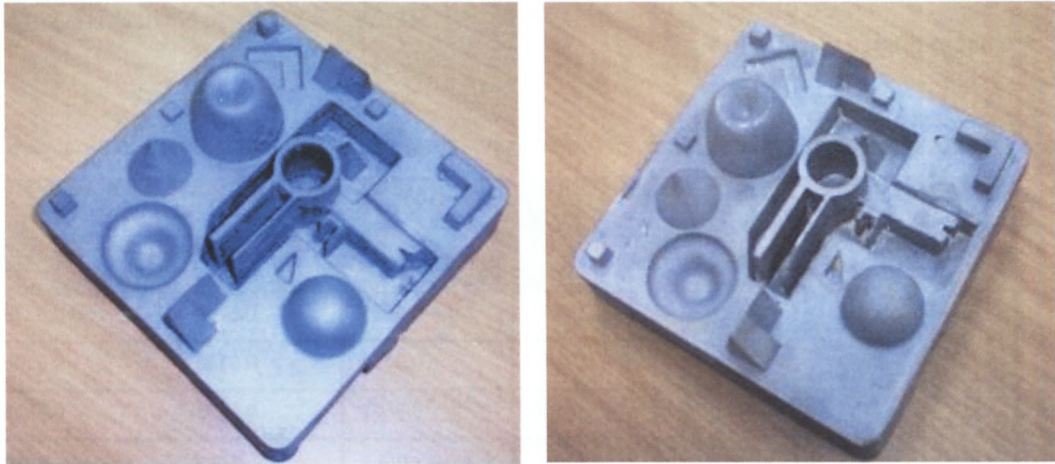

Figure 6.12 Latest Titanium Castings produced from 3DP and LS patterns



(A) (B)  
Figure 6.13 Ti castings from a Polyamide (A) and Alumide (B) Dies

The castings shown in figure 6.13 were produced from the Polyamide and Alumide dies. They show good surface finish as well as good definition, however porosity is still visible. Each of the castings was measured on the Coordinate Measuring Machine (CMM) using the same programs as before and the data analysed.

#### 6.4.1. STATISTICAL OBSERVATIONS

The histograms and medians indicate that the error distributions are generally centered around 0.638 mm.

Confidence intervals are constructed using standard errors. All castings have small standard errors indicating that the sample size used is sufficient to support the results with good confidence (Table 6.11).

Skewness show positive values for all four castings, which means that the distributions are hanging over to the left. The castings did not shrink as much as expected.

Kurtosis values are all higher than 3 and for the 3DP and LS, their distributions are considered Leptokurtic. Leptokurtic indicates that the distributions have high peaks, thin midranges and fat tails. The largest and smallest measured values average at 12.806 mm and 12.273 mm. The values

for the Alumide and Polyamide castings are less than 3 indicating a platykurtic, with low peak and a flat midrange distribution.

**Table 6.11 Ti Castings Statistics**

Descriptive Statistics	Ti Casting (3DP)	Ti Casting (SLS)	Ti Casting (Alumide)	Ti Casting (Polyamide)
Mean	0.6444	0.6535	0.6279	0.6279
Standard Error	0.0141	0.0108	0.0136	0.0136
Median	0.6308	0.6632	0.5896	0.5896
Mode	n/a	n/a	n/a	n/a
Standard Deviation	0.3226	0.2474	0.3109	0.3109
Sample Variance	0.1041	0.0612	0.0967	0.0967
Kurtosis	12.2725	12.8062	2.8984	2.8984
Skewness	1.8416	1.4965	1.1350	1.1350
Range	3.4645	2.8264	2.1304	2.1304
Minimum	0.0605	0.1041	0.0911	0.0911
Maximum	3.5250	2.9304	2.2215	2.2215
Sum	337.00	341.13	328.39	328.39
Count	523	522	523	523
Largest(1)	3.5250	2.9304	2.2215	2.2215
Smallest(1)	0.0605	0.1041	0.0911	0.0911
Confidence Level (95.0%)	0.0277	0.0213	0.0267	0.0267

The confidence level indicates that the SLS castings will have a mean deviation  $0.6535 \pm 0.0213$ . The Ti casting show slightly higher mean values as compared to Al and Mg castings. This is however due to the presence of the Alpha layer which was not removed and is approximately 0.2 mm thick (Rossouw, 2008). This layer is removed using specialized processes and is discussed in more detail in section 6.5.4.2.

#### 6.4.2. TITANIUM SHRINKAGE VALUE

The largest dimensional measurements were used to calculate the shrinkage value for each casting. Small values were discarded. These are more prone to influence of warpage and surface roughness, which then gives outliers in the data. Shrinkage is determined by comparing the casting and pattern measurements:

$$\%Shrinkage = \frac{PatternMeasurement - CastingMeasurement}{CastingMeasurement} \times 100$$

The average shrinkage value calculated was 1.145%. One of the main objectives of the research was to determine shrinkage as limited or no published shrinkage data exist and hence cannot be compared.

**Table 6.12 Shrinkage Value for Ti Castings**

Ti Casting	Qty	Shrinkage%
3DP	1	1.09%
LS	1	0.74%
Alumide Die	1	1.38 %
Polyamide Die	1	1.37 %
<b>Avg. Shrinkage for Titanium:</b>		1.145 %

Table 6.12 above shows a large variation between the shrinkage values of the casting produced from the LS pattern and that of the castings produced from the Polyamide and Alumide dies. The measurement data showed that the LS pattern was smaller than the wax patterns produced from the two dies. This is most likely the cause of the discrepancy in shrinkage values shown in the table above.

#### 6.4.3. ANALYSIS OF THE BUILT FEATURES (TI CASTINGS FROM LM PATTERNS AND DIES)

A basic tolerance of  $\pm 0.5$  mm is used for all feature measurements on all castings. See Appendix H for data.

##### Cubes

The cubes were used to check for straightness in the x and y direction, by checking if they were built in a straight line. All cubes look good with only one measurement out of tolerance deviation, E9 with a value of 1.066 mm on the 3DP casting.

##### Wedges

All wedges have good dimensions and showed a slight improvement in perpendicularity and angularity compared to the Al and Mg castings, however is still not within the specified tolerance.

##### Pyramid

The measurements are better than that of the Al and Mg castings but the deviations are still high, the highest being 2.332mm for DD2 on the Alumide casting.

##### Cylinder

All castings measurement on cylindrical features is within tolerance and showed good definition.

##### Thin Walls

All thin walls on castings present good thickness dimensions and parallelism. The 3Dp pattern however showed slightly higher values, T10 being 0.581 and T11 being 0.653.

##### Rectangular Protrusion/Hole

The rectangular protrusions and rectangular holes present good dimensional and perpendicularity values for all castings, except for poor perpendicularity values on the 3DP casting with a highest value of 1.005 for T18.

Tri-angular Hole

The tri-angular holes on all castings present excellent perpendicularity and depth values, all well within tolerance.

Cone

All cones exhibit good angularity and coaxiality. The cones on all castings have good circular runout in terms of circles measured around the cone, when using the actual cone axis. All castings have poor axial runout values.

Dome

All domes exhibits good circular runout, symmetry and concentricity, all well within tolerance.

All measured feature data can be found in the Appendix H.

The Dimensional Accuracy Index (DAI) based on the features and tolerances measured, indicate that the LS casting had the best accuracy with a value of 87.04%. Visual inspection of castings shows that the LS casting has the best definition and reproduction of features as well.

**Table 6.13 DAI of Titanium Castings**

DAI - Titanium Castings					Dimensional Accuracy index (DAI = Good/Total x 100%)
High	$X > 0.5$				
Good	$-0.5 < X > 0.5$				
Low	$X < -0.5$				
Pattern Model	Counts				
	High	Good	Low	Total	
<b>3DP</b>	26	74	8	<b>108</b>	68.52%
<b>SLS</b>	13	94	1	<b>108</b>	87.04%
<b>Alumide</b>	23	69	16	<b>108</b>	65.83%
<b>Polyamide</b>	15	69	24	<b>108</b>	63.89%

#### 6.4.4. ANOVA ANALYSIS

The following hypothesis is stated to determine whether there is a significant difference between the accuracy of the castings from LM Patterns and dies:

$H_0$  : All mean measurements are equal

$H_1$  : All mean measurements are not equal

Table 6.14 below provides the results when tested against a 95 % confidence level.

**Table 6.14 Single factor ANOVA Results @ 95% Confidence**

Anova: Single Factor	Titanium Castings					
SUMMARY						
Groups	Count	Sum	Average	Variance		
3DP	523	-0.777	-0.0015	0.0803		
SLS	523	-13.41	-0.0256	0.0262		
Alumide	523	21.938	0.0419	0.1570		
Polyamide	523	-25.138	-0.0481	0.1016		
ANOVA						
Source of Variation	SS	df	MS	F	P-value	F crit
Between Groups	2.3290	3	0.7763	8.5058	1.29E-0	2.6092
Within Groups	190.5719	2088	0.0913			
Total	192.9008	2091				

The results indicate that the Null hypothesis cannot be accepted.

#### 6.4.5. TITANIUM POST PROCESSING

After the investment casting of Ti has been completed, a number of post processes are required to obtain the maximum mechanical properties from them. These processes are specialised and are available at the CSIR. However, their facilities are either outdated or need upgrading and have therefore applied for grants/funding to meet these requirements. These post processes for Ti castings are as follows:

- Hot Isostatic Pressing- HIPing/HIP
- Chemical Milling/ Laser Ablation
- Vacuum heat treatment

Chemical milling and Vacuum heat treatment are beyond the scope of this study and therefore not reported on further. Laser ablation and HIP are discussed separately and in more detail in the next section.

#### 6.4.5.1. HOT ISOSTATIC PRESSING (HIP)

In addition to heat treatment all castings require a HIP (Hot Isostatic Press) cycle to close all internal porosity and shrinkage, which are present in all castings due to the high solidification rate of titanium and its low density that renders low metallostatic pressure during pouring and solidification, (Rossouw, 2009).

HIPing involves placing the castings in a vessel. A vacuum is then drawn and the loaded castings are heated to the required HIPing temperature. The HIPping temperature is the temperature where the material starts to behave visco-plastically. The vessel is then pressurised with argon to ultra high pressure i.e.1000-2000bar. The internal porosity and shrinkage closes under pressure as the casting exhibits visco-plastic behaviour. This gives the casting the maximum obtainable density. Care should just be taken not to cause localised melting of the casting as that can damage the microstructure, Rossouw, (2009). Any surface defects such as porosity, must first be welded as this cycle will only close sub surface defects.

The required equipment is thus far not available in South Africa and hence could not be investigated.

#### 6.4.5.2. LASER ABLATION

During the casting process, a hard alpha case forms on the surface due to interaction between the Ti and the face coat (figure 6.14). According to Rossouw, 2008, this layer with a thickness of  $\pm 200\mu\text{m}$  impairs the mechanical properties of Ti and must be removed. Due to the high hardness of this layer (700-900 Vickers, around 65 HRC) the use of the conventional milling process is not applicable.

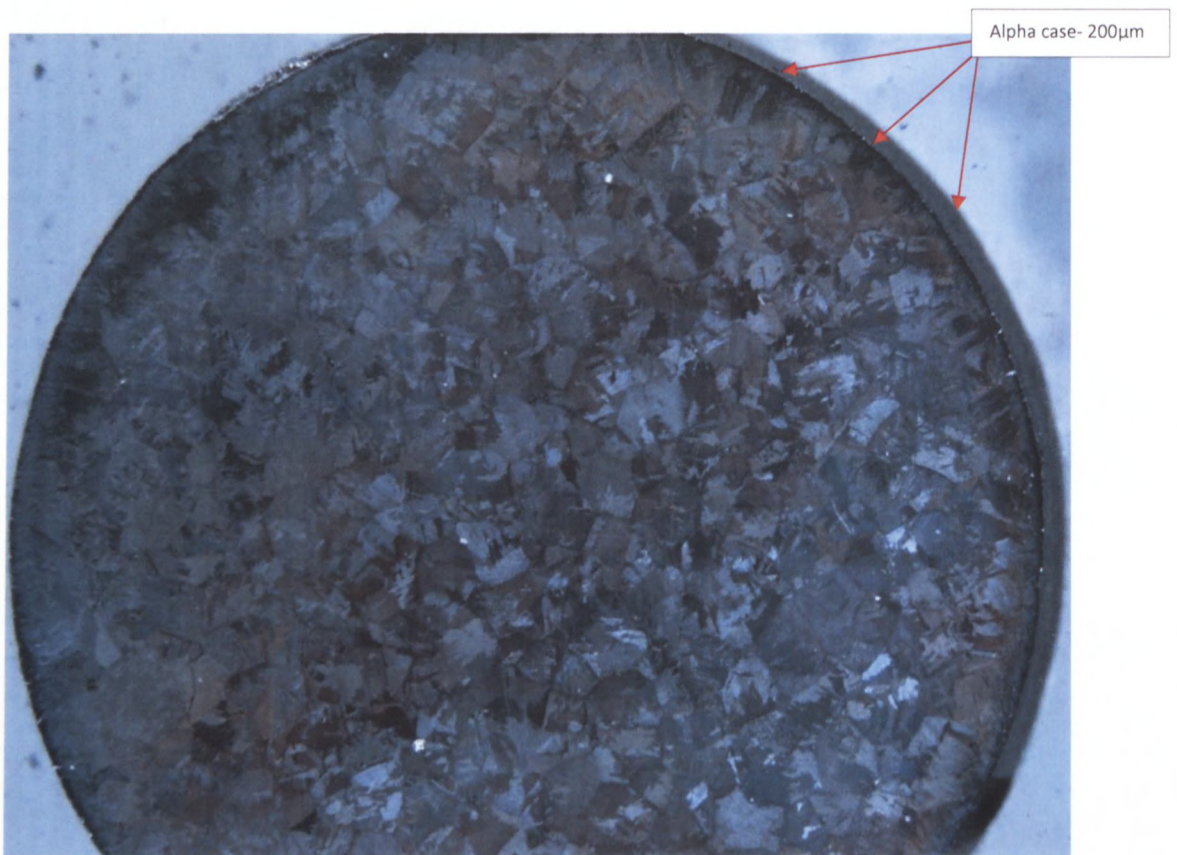

**Figure 6.14 Diameter 18mm Rod cross-section- Red arrows indicating Alpha case layer**  
(Adapted from Rossouw, 2008)

Figure 6.15 shows a sample done on a laser ablation machine (CSIR), and Table 6.15 reflects the roughness values obtained from the various surfaces.

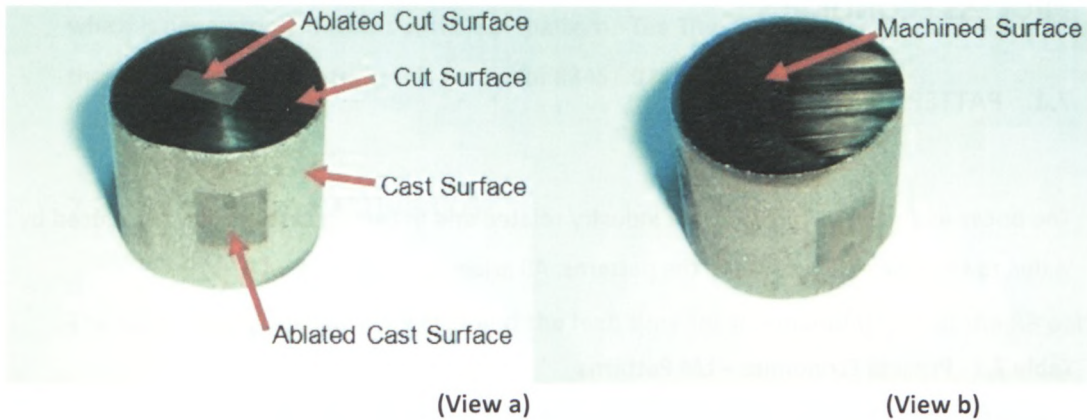

Figure 6.15 Laser Ablation Titanium Test Piece  
(Adapted from Dimitrov *et al.*, 2010)

Table 6.15 Ablated Titanium Surface Roughness's (Adapted from Dimitrov *et al.*, 2010)

	Cast Surface	Laser Ablated Cast Surface	Cut Surface	Laser Ablated Cut Surface	Machined Surface
No.	$Ra$ ( $\mu\text{m}$ )	$Ra$ ( $\mu\text{m}$ )	$Ra$ ( $\mu\text{m}$ )	$Ra$ ( $\mu\text{m}$ )	$Ra$ ( $\mu\text{m}$ )
1	10.44	13.69	2.95	3.58	0.15
2	7.3	15.02	1.94	3.48	0.17
3	6.94	17	2.58	3.10	0.20
4	7.61	16.91	1.99	3.47	0.24
5	7.82	17.2	2.2	3.52	0.18
6	6.87	16.67	2.31	3.50	0.14
7	7.54	17.28	2.08	3.41	0.16
8	9.93	16.27	1.42	3.45	0.18
9	7.26	18.07	1.87	3.47	0.17
10	7.97	17.86	1.95	3.56	0.17
<b>Ra (avg.)</b>	<b>7.968</b>	<b>16.597</b>	<b>2.129</b>	<b>3.454</b>	<b>0.176</b>

$Ra$  was selected as the roughness representative parameter to be measured using a cut-off length of 0.8 mm. Ten random measurements were taken and the average value obtained. The measuring results show that the surface achieved after the laser ablation is rough. Depending on the specific requirements, the final product will need further processing. The process also proved to be slow and costly.

## 7. PROCESS ECONOMICS

### 7.1. PATTERN AND DIE COSTS

The prices as shown in Table 7.1 are industry related and in certain cases it can be reduced by 15 % due to the research purpose of the patterns. All prices exclude 14 % VAT.

**Table 7.1 Process Economics – LM Patterns**

Supplier		Cost per Pattern
<b>RPDL LABORATORY - Stellenbosch University</b>		
3DP 4mm	Wax Infiltrated Pattern	R1000.00
<b>CENTRE OF RAPID PROTOTYPING AND MANUFACTURING – Central University of Technology, Freestate</b>		
LS 3mm	Polystyrene Pattern	R2898.00
LS Pump 440-01	Polystyrene Pattern	R17 959.00
Polyamide Die	polyamide	R7910-00
Alumide Die	Alumide	R15 095
<b>INSTITUTE OF TECHNOLOGY INNOVATION - Tshwane University of Technology</b>		
ThermoJet 3mm	Wax Pattern	R3451.02
<b>COUNCIL OF SCIENTIFIC AND INDUSTRIAL RESEARCH-CSIR</b>		
Wax Injected Patterns	289B Green Wax	R250-00/per pattern

The most influential factor on price is material cost. Manufacturing time and post processing also have a slight influence on the price. Each supplier can manufacture a pattern in roughly one day, depending on the size of the pattern.

3DP patterns are the cheapest to produce, with a cost of R 1000 per pattern, due to the low cost of material compared to LS and the ThermoJet. The LS polystyrene pattern has a cost of R2898

which is nearly triple the cost of the 3DP pattern. The ThermoJet uses expensive material and has the highest cost per pattern with a value of R3451.02.

## 7.2. INVESTMENT CASTING COST

The table below indicates the cost and the lead time for the manufacture of the RP patterns.

**Table 7.2 Casting prices**

Description	Manufacturing Time	Pattern cost (R)	Mg Casting Price Estimate (R)	Ti Casting Price Estimate (R)
3DP	2 days	1000.00	56 576.00	15910.00
LS	2 days	2898.00	56 576.00	15910.00
ThermoJet	2 days	3452.00	56 576.00	15910.00
Polyamide wax	2 days	3452.00	56 576.00	15910.00
Alumide wax	2 days	3452.00	56 576.00	15910.00

In the case of Ti and Mg castings, it remains an expensive procedure due to the processing difficulties that are inherent to the materials. The process cost per casting for Ti is approximately four times that of the same component in aluminium and is about ten times that for Mg as illustrated in the table 7.2.

## 8. CONCLUSIONS AND RECOMMENDATIONS

### Rapid Patterns

The study presented in this report confirms that the LS patterns have the best dimensional and geometric accuracy as shown in tables 6.4 and 6.9. The 3DP patterns can be used for IC of Mg and Ti, however the model's wall thickness did cause the pattern to sag slightly. Although the 3DP pattern produced a casting it would be more suited for components with a greater wall thickness. The reproduction of certain geometric features was not good and therefore careful consideration should be taken, when selecting this process specifically looking at the geometric shapes of an intended component.

The ThermoJet pattern produced Al and Mg castings, but collapsed during the shell preparation for the Ti casting. The collapse occurred due to a reaction between the pattern material and the primary face coat (Rossouw, 2009). It can be concluded that in the present process, ThermoJet patterns are not suitable. A full composition analysis should be conducted on the ThermoJet patterns to determine exactly what element/s are causing the reaction with the face coat.

### Rapid Dies

Also regarding the Rapid Dies the study confirmed that errors on the dies are random and not systematic. The alumide and polyamide dies both exhibit close-to-normal distributions according to the shape of their histograms. Statistics indicate that the dies are slightly smaller than their original CAD model, meaning that the shrinkage values used during building could be slightly increased. Confidence levels indicate that the dies are dimensionally accurate.

Both die cavities demonstrate dimensional and geometric accuracy with few values and features that do not conform to the specified tolerance. This indicates that both materials can provide accurate dies for the creation of wax patterns for investment casting. The DAI is only an estimation method and there is little difference between the two values. However, the ANOVA analysis concludes that there is still a significant difference in accuracy between the two die types.

It can be concluded that the alumide die is more accurate than the polyamide die - based on the statistical analysis shown in tables 8.6, 8.10 and 8.14. Both dies provided good features with adequate definition.

The longer use of the dies to create patterns showed that they are only applicable for low volume runs - less than 20 patterns. The continuous pressure and the heat from the hot wax injected affected the die material and they started losing integrity.

### Castings

The research showed the difficulty in the process of producing Ti and Mg castings (Rossouw, 2009). The CSIR had retrofitted existing equipment to be able to do the investment casting of these materials. Although castings were produced, by the end of this study, the process had still not been reliable.

The first casting obtained for the Ti material was not usable due to certain process problems as discussed previously. The correction of these problems allowed for a second attempt, which produced good castings, however there were still porosity issues. The Mg castings proved more successful than the Ti castings.

Before the Ti castings are usable they needed to undergo Hot Isostatic Pressing (HIP) procedure to close up porosity and chemical milling to remove the alpha layer. This was not possible due to facility problems as discussed, however there has been development in the chemical milling side and data should be available in late 2011. No HIP facility exists in South Africa and CSIR has put forward a recommendation to establish such a facility.

### Pattern, Die and Casting Economics

Material cost is still one of the most influential factors on the final expenditure for patterns and dies. Manufacturing time and post processing also have a slight influence on the price.

3DP starch based and wax infiltrated patterns are the cheapest to produce due to the low cost of its materials compared to LS polystyrene and ThermoJet wax patterns. The cost of a LS polystyrene pattern is nearly three times the cost of a 3DP pattern. The ThermoJet uses the most expensive material of all the processes and has the highest cost per pattern, more than three and a half times the cost of a 3DP pattern.

The LS powders and reinforcement materials used for the alumide and polyamide dies are expensive. It is costly, but compared to conventional tooling for the production of only one pattern it is a minimal price to pay. The dies were grown with a 5 mm wall thickness; if the dies were grown solid the cost would have been more than double for each die. The higher cost of the alumide die does not justify the alumide die when only accuracy and surface finish are taken into account. However, tool life might justify the higher cost depending on the number of patterns required.

Each supplier can manufacture a pattern in roughly one day, depending on the size of the pattern. Suppliers can roughly produce and deliver a die in a week's time. The reinforcement of the die and injection will take further two or three days before delivery of the first pattern. Producing more patterns from each die will drastically cut the cost per pattern.

#### Future Research

Some avenues for future research can be summarised as follows:

1. Further studies are necessary in order to develop a reliable and stable casting process for Ti and Mg alloys. When this process has been established, the results in this report should be verified.
2. Further studies are required in order to establish the actual tool life of rapid dies made by LS technology. The inclusion of other technologies such as Selective Laser Melting and similar, capable of processing of metal powders, is recommended.
3. A reliable process chain for casting of Ti alloys up to a final stage, i.e. including of face coat, HIP and Chemical Milling issues, needs to be established. This requires further substantial efforts, capacity and funds.

4. The development of a reliable process for investment casting of large, high added value components particularly for aerospace and automotive industries for light metals, including for Aluminium, is necessary. The study presented in this report on that topic shows, how uncompetitive is the SA foundry industry in this regard. The development of capabilities in this direction is of utmost importance, if the local IC industry desires to be a competitive part of the global supply chain.

## 11. References

Anonymous, 2003, *Investment Casting*, Manufacturing Technology, Course notes, Peninsula Technikon, unpublished

Anonymous, *Investment Casting Process basics*, URL:

<http://www.hitchiner.com/HIMCO/Basics.html>

[15 September 2006]

Anonymous, *The Basics of the Investment Casting Process*, URL:

<http://www.kovatchcastings.com/technicalinfo.htm>

[15 September 2006]

Arcam

<http://www.arcam.com/technology/faq/electron-beam-melting-ebm.aspx>,

[15 September 2009]

Beeley, P. 2001. *Foundry Technology*, Butterworth: Heineman 2<sup>nd</sup> ed.

BIBA, Rapid Prototyping Group, Bremen Institute of Industrial Technology and Applied Work Science at the University of Bremen (BIBA)

<http://www.ppc.biba.uni-bremen.de/projects/rp/fdm.html>

5 Aug 2006

Blake P., Fodran E., Koch M., Menon U., Priedeman B., Sharp S., 1997, *FDM of ABS patterns for investment casting*. Proc Solid Freeform Fabrication Symposium, Austin, TX, 11–13 August, pp. 195–202

Boothroyd, G., Dewhurst, P., Knight, W., 1994, *Product Design for Manufacture and Assembly*, Computer-Aided Design, Vol. 26, No. 7, pp. 505-519

Campbell, R.I., Martorelli, M., and Leec, H.S., 2002, *Surface roughness visualisation for rapid prototyping models*, Computer Aided Design, Vol. 34, No. 10, pp. 717-725

Cheah, C.M., Chua, C.K., Lee, C.W., Feng, C., Totong, K., 2005, *Rapid prototyping and tooling techniques: a review of applications for rapid investment casting*, The International Journal of Advanced Manufacturing Technology, Vol. 25, No. 1-2, pp. 308–320

Christensen, A., Lippincott, A., Kircher, R., *Qualification of Electron Beam Melted (EBM) Ti6Al4V-Eli for Orthopaedic Implant Applications.2007*, Medical Modelling LLC.

*Different Print Processes*, Castle Islands worldwide guide to rapid prototyping, URL: <http://home.att.net/~castleisland/>

[12 August 2006]

Dimitrov, D., De Beer, N., Bond, B., 2006 a, *The Clam Technology Report*, Dept. Industrial Engineering, SU, unpublished, March 2006

Dimitrov, D., Deez, B., Hugo, P., 2008, *Suitability of Layer Manufacturing Technologies for Rapid Pattern Making in Investment Casting*, 9<sup>th</sup> RAPDASA Annual International Conference, Bloemfontein, South Africa, 13-15 November 2008

Dimitrov, D., Hugo, P., 2008, *Investigations towards the Suitability of Layer Manufacturing Methods for Rapid Tooling Development*, AMTS Interim Project Progress Report 3, Year 3, November 2008, Department of Industrial Engineering, Stellenbosch University, unpublished report.

Dimitrov, D., Hugo, P., Deez, B., 2008, *Investigations towards the Suitability of Layer Manufacturing Methods for Rapid Tooling Development*, AMTS Interim Project Progress Report 2, Year 3, August 2008, Department of Industrial Engineering, Stellenbosch University, unpublished report.

Dimitrov, D., Hugo, P., Deez, B., 2010, *Suitability of Layer Manufacturing Methods and their Combinations with Subtractive Processes for Rapid Product Development*, AMTS Final Project Progress, Year 4, March 2010, Department of Industrial Engineering, Stellenbosch University, unpublished report.

Dimitrov, D., Schreve K., De Beer, N., P.-J. Christiane P.J., 2007, *Three Dimensional Printing In South African Industrial Environment*, South Africa, SA Journal of Industrial Engineering 2008, Vol. 19, No.1, 195-21

Dimitrov, D., Schreve, K., 2002, *Rapid prototyping of a differential housing using three-dimensional printing technology*, ICMA Proceedings, Hong Kong, Professional Engineering Publishing, pp. 483-490

Dimitrov, D., Van Wijck, W., Schreve, K., De Beer, N., 2006 b, *Investigating the achievable accuracy of three dimensional printing*; Rapid Prototyping Journal, Vol.12, No.1, pp. 42-52

Electro Optical Systems

<http://www.eos.info/products.html?L=1>

20 January 2008

European Commission, *Sixth Framework programme (FP6)*, IP Project, Euro Tooling 21, 2006.

Grimm, T., 2002, *Stereolithography, Selective Laser Sintering and Polyjet: Evaluating and Applying The Right Technology*, Time-Compression Technologies, Vol. 10, No. 4

Hague, R., Mansour, S., Saleh, N., 2004, *Material and Design Considerations for Rapid Manufacturing*; International Journal of Production Research, Vol. 42, No. 22, pp. 4691–4708

Hinckley, B., 1995, *Direct Investment Casting of Laminated Object Manufacturing*, MScEng Thesis, Brigham Young University

Hong S., Byun , Kwan H. Lee, 2006, *Determination of optimal build direction in rapid prototyping with variable slicing*, The International Journal of Advanced Manufacturing Technology, Vol. 28, No. 3-4, pp. 307-313

Hugo, P. 2008, *Suitability of Layer Manufacturing Technologies for Rapid Tooling Development in Investment Casting*. Unpublished Msc, University Stellenbosch, Stellenbosch.

Ingole, D.S., Kuthe, A.M., Thakare, S. B., Talankar, A.S., 2009, *Rapid Prototyping- A Technology Transfer Approach for Development of Rapid Tooling*, Rapid Prototyping Journal, Vol.15, No 4, pp. 280-292

ISO 1101:2004 Geometrical Product Specifications (GPS) - Geometrical tolerance - Tolerances of form, orientation, location and run-out

Jibin Zhao, Weijun Liu Jianhuang Wu, 2005, *Determination of Optimal Build Orientation Based on Satisfactory Degree Theory for RPT*, Proceedings of the Ninth International Conference on Computer Aided Design and Computer Graphics, Vol. 00, pp. 225-230

Kruth, J-P., Levy, G., Klocke, F., Childs, T.H.C., 2007, *Consolidation phenomena in laser and powder-bed based layered manufacturing*, Annals of CIRP, Vol. 56, No. 2, pp. 730-759

Levy G.N., Schindel R., Kruth J.P., 2003, *Rapid Manufacturing and Rapid Tooling with Layer Manufacturing technologies, State of the Art and Future Perspectives*, Annals of the CIRP, Vol. 52, No. 2, pp. 1-21

Maji, P.K., Banerjee, P.S., Sinha, A., *Application of Rapid Prototyping and Rapid Tooling for Development of Patient-specific Craniofacial Implant: An Investigative Study*, The International Journal of Advanced Manufacturing Technology, Vol. 36, pp. 510–515

MCP-Group

<http://www.mcp-group.com/rpt/rpttslm.html>

25 January 2008

Montgomery, D.C., Runger, G.C., 2003, *Applied Statistics and Propability for Engineers*, 3<sup>rd</sup> ed

Mueller, T., 2005, *Rapid Prototyping Patterns Create New Opportunities for Investment Casting*, CASTEXPO, American Foundry Society Conference, St. Louis, MO.

O'Shaughnessy. K., 2004, *Investing with Rapid Prototyping*, *Modern Casting*, Vol.94, No. 10 pp. 23–26

Pom-Group

[http://www.pomgroup.com/tool\\_reconfiguration1.asp](http://www.pomgroup.com/tool_reconfiguration1.asp)

[16 September 2009]

Project Consortium, 2006, *Investment Casting Capabilities for Light Metal Alloys*, Project Plan, Advanced Manufacturing Technology Strategy (AMTS), Department of Science and Technology, South Africa

Rossouw, P., 2008, Ti Investment casting project, AMTS - Progress Report, April 2008, CSIR, unpublished report

Rossouw, P., 2009, Investment Casting of Lightweight Metals, AMTS - Final Progress Report, May 2009, CSIR, unpublished report

Smugeresky, J.E., Keicher, D.M., Romero, 1997, *Laser Engineered Net Shaping (LENS™) Process: Optimization of Surface Finish and Microstructural Properties*, Sandia National Laboratories, California, New Mexico.

South Africa. Department of Science and Technology (2006), *Investment Casting Capabilities for Light Metal Alloys, Project Plan, Automotive and Aerospace Industry Sectors: 22-24 February 2006*. Pretoria: Advanced Manufacturing Technology Strategy (AMTS).

Tong K, Joshi S, Lehtihet A., 2004, *Software Error Compensation Of Rapid Prototyping*, Precision Engineering, Vol. 28, No. 3, pp. 280-292

Van Wyk, J.A., 1992, *Simulation of a Robot Controlled Investment Casting Process*, MScEng Thesis, University of Stellenbosch

Wohlers, T., *Wohlers Report, 2007, Rapid Prototyping, Tooling & Manufacturing, State of the Industry*, Annual Worldwide Progress Report, Fort Collins, Colorado

## *Appendix*

Appendix A	Features Measured - Drawings	116
Appendix B	Aluminium Castings - Features CMM Data	120
Appendix C	Aluminium Castings - Statistical CMM Raw Data (3D-Tol Data)	135
Appendix D	Aluminium Castings - Histograms (3D-Tol Data)	169
Appendix E	Magnesium Castings - Features CMM Data	172
Appendix F	Magnesium Castings - Statistical CMM Raw Data (3D-Tol Data)	193
Appendix G	Magnesium Castings - Histograms (3D-Tol Data)	246
Appendix H	Titanium Castings - Features CMM Data	249
Appendix I	Titanium Castings - Statistical CMM Raw Data (3D-Tol Data)	271
Appendix J	Titanium Castings - Histograms (3D-Tol Data)	324
Appendix K	Pattern - Statistical CMM Raw Data (3D-Tol Data)	327
Appendix L	Casting - Statistical CMM Raw Data (3D-Tol Data)	338

*Appendix A      Features Measured -  
Drawings*

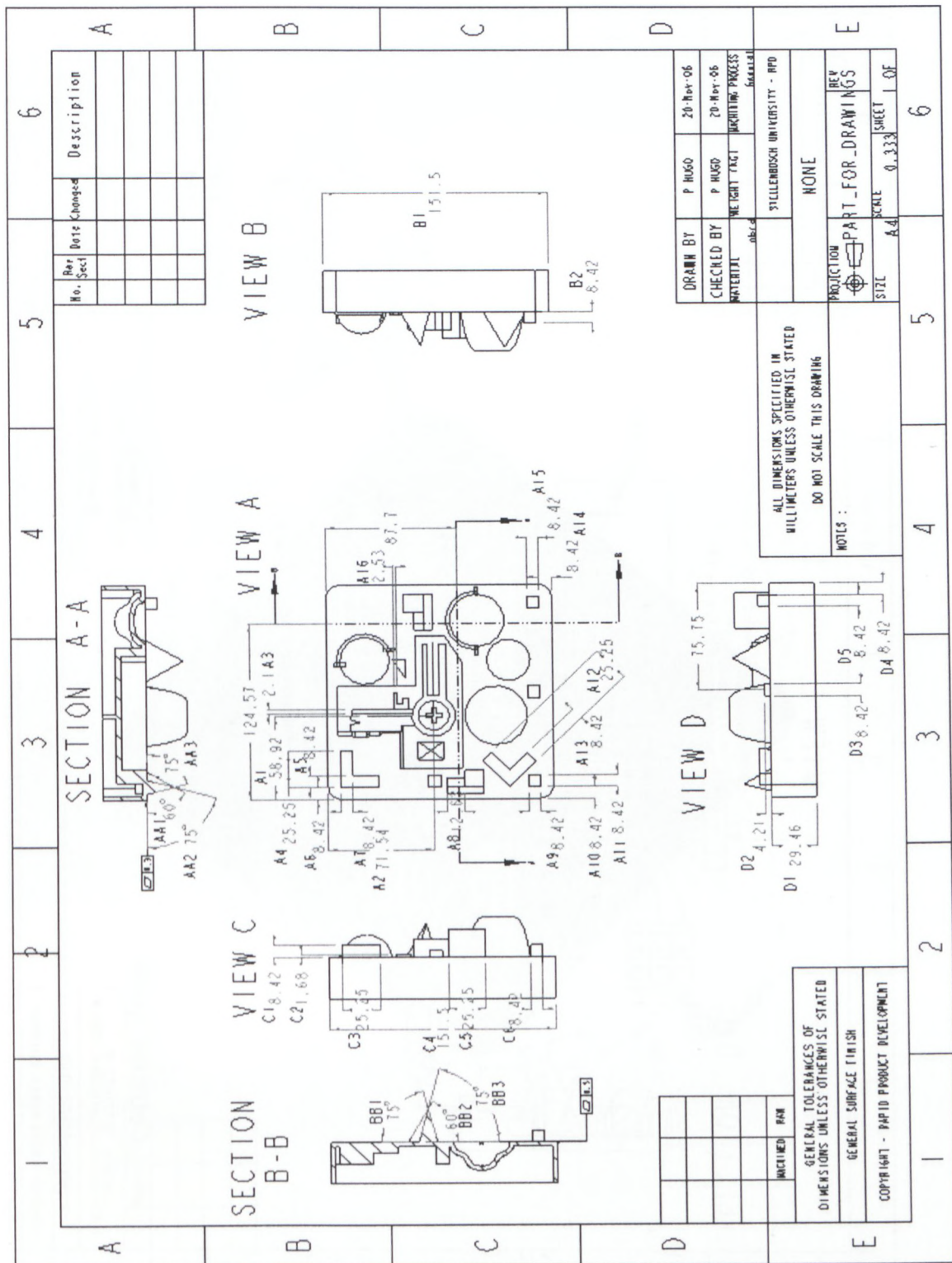

Figure A Features Measured a

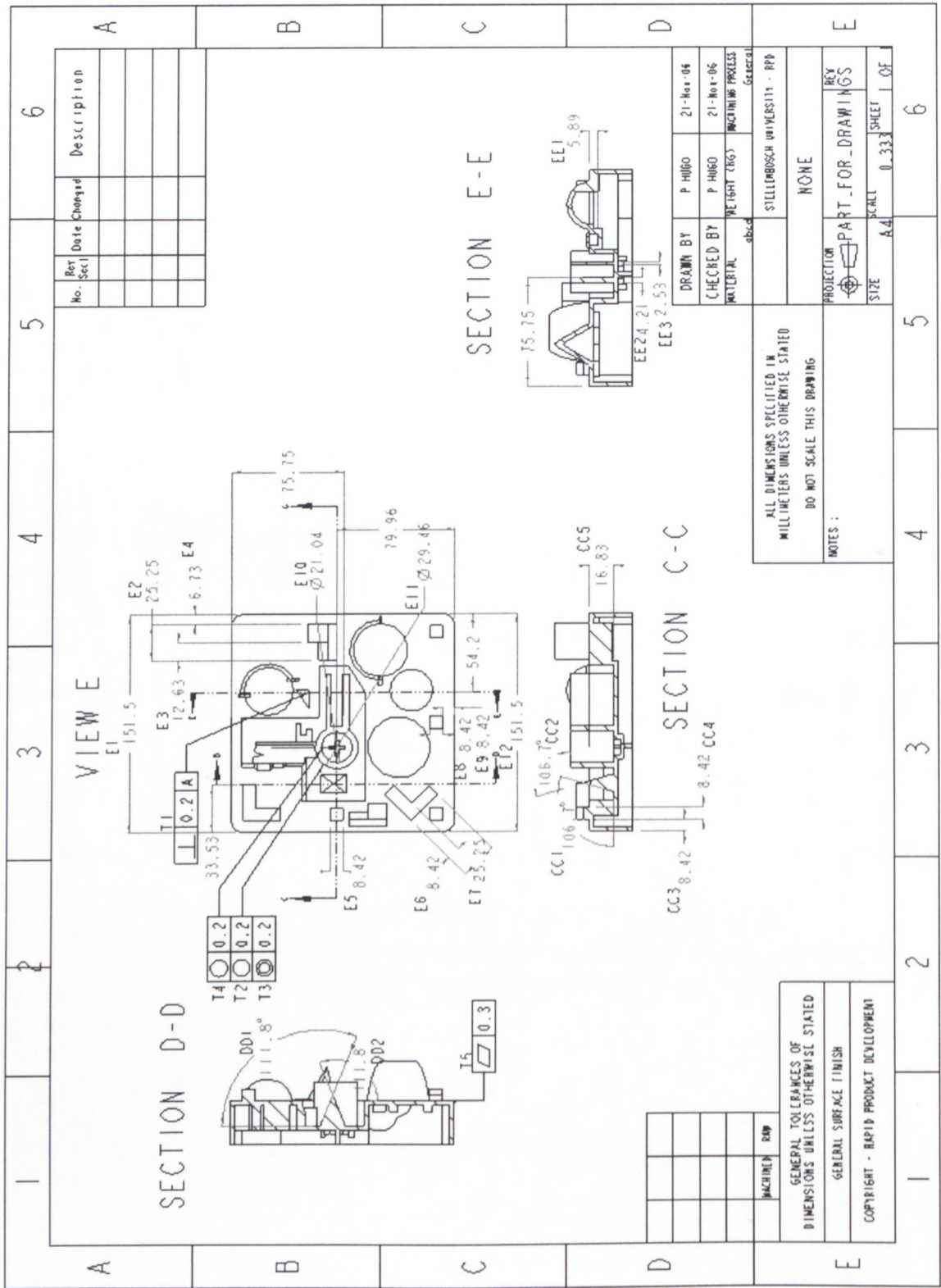

Figure B Features Measured b



*Appendix B      Aluminium Castings -  
Features CMM Data*

A basic tolerance of  $\pm 0.5$  mm is used for all feature measurements on all castings.

### Feature Tolerances – 3DP Aluminium Casting

Feature Tolerances - Aluminium Casting (3DP 5) 3mm										
Tolerance No.	Feature	Tol.ElemName	Compared to	Type of Tolerance	Spec.	Lower Tol.	Upper Tol.	Actual	Tol. Deviation	Result
A1	Square Base	Line	Point	Distance	60.03	-0.500	0.500	60.039	0.005	Good
A2	Pattern	Line	Point	Distance	70.76	-0.500	0.500	70.421	-0.344	Good
A3	Pattern	Line	Point	Distance	2.08	-0.500	0.500	1.755	-0.322	Good
A4	Rectangular Protrosion	Line	Point	Distance	25.16	-0.500	0.500	24.381	-0.778	Low
A5	Rectangular Protrosion	Line	Point	Distance	8.39	-0.500	0.500	7.970	-0.418	Good
A6	Rectangular Protrosion	Line	Point	Distance	8.04	-0.500	0.500	8.114	0.079	Good
A7	Pattern	Line	Point	Distance	8.12	-0.500	0.500	7.659	-0.463	Good
A8	Wedge X	Line	Point	Distance	13.28	-0.500	0.500	12.715	-0.564	Low
A9	Cube 1	Line	Point	Distance	8.02	-0.500	0.500	8.120	0.104	Good
A10	Cube 1	Line	Point	Distance	8.21	-0.500	0.500	8.188	-0.017	Good
A11	Cube 1	Line	Point	Distance	8.31	-0.500	0.500	7.792	-0.516	Low
A12	Rectangular Hole	Line	Point	Distance	24.89	-0.500	0.500	24.901	0.009	Good
A13	Rectangular Hole	Line	Point	Distance	8.39	-0.500	0.500	8.706	0.321	Good
A14	Cube 2	Line	Point	Distance	8.49	-0.500	0.500	7.973	-0.515	Low
A15	Cube 2	Line	Point	Distance	7.98	-0.500	0.500	7.671	-0.308	Good
A16	Pattern	Line	Point	Distance	1.97	-0.500	0.500	1.729	-0.237	Good
B1	Square Base	Line	Point	Distance	150.15	-0.500	0.500	149.712	-0.441	Good
B2	Cube 1	Line	Point	Distance	8.22	-0.500	0.500	8.007	-0.214	Good
C1	Rectangular Protrusion	Line	Point	Distance	8.52	-0.500	0.500	8.267	-0.254	Good
C2	Pattern	Line	Point	Distance	0.86	-0.500	0.500	1.175	0.317	Good
C3	Rectangular Protrusion	Line	Point	Distance	24.51	-0.500	0.500	24.103	-0.405	Good

C4	Square Base	Line	Point	Distance	150.15	-0.500	0.500	149.712	-0.441	Good
C5	Wedge X	Line	Point	Distance	24.77	-0.500	0.500	23.355	-1.417	Low
C6	Cube 1	Line	Point	Distance	8.15	-0.500	0.500	7.990	-0.157	Good
CC3	Cube 1	Line	Point	Distance	8.31	-0.500	0.500	7.792	-0.516	Low
CC4	Cube 1	Line	Point	Distance	8.21	-0.500	0.500	8.188	-0.017	Good
CC5	Cylinder Depth	Line	Point	Distance	16.71	-0.500	0.500	16.379	-0.330	Good
D1	Square Base Depth	Line	Point	Distance	29.33	-0.500	0.500	29.480	0.150	Good
D2	Cube 3	Line	Point	Distance	3.92	-0.500	0.500	3.835	-0.080	Good
D3	Cube 3	Line	Point	Distance	8.59	-0.500	0.500	8.214	-0.374	Good
D4	Cube 2	Line	Point	Distance	8.15	-0.500	0.500	8.087	-0.060	Good
D5	Cube 2	Line	Point	Distance	8.58	-0.500	0.500	8.268	-0.313	Good
E1	Square Base	Line	Point	Distance	150.81	-0.500	0.500	150.575	-0.230	Good
E2	Wedge Y	Line	Point	Distance	25.49	-0.500	0.500	24.861	-0.631	Low
E3	Wedge Y	Line	Point	Distance	12.87	-0.500	0.500	13.136	0.269	Good
E4	Wedge Y	Line	Point	Distance	6.95	-0.500	0.500	6.568	-0.378	Good
E5	Cube 4	Line	Point	Distance	8.13	-0.500	0.500	7.752	-0.376	Good
E6	Rectangular Hole	Line	Point	Distance	8.61	-0.500	0.500	9.176	0.564	High
E7	Rectangular Hole	Line	Point	Distance	25.20	-0.500	0.500	25.601	0.397	Good
E8	Cube 3	Line	Point	Distance	8.19	-0.500	0.500	7.554	-0.632	Low
E9	Cube 3	Line	Point	Distance	8.67	-0.500	0.500	7.323	-1.349	Low
E10	Cylinder Inner Diameter	Line	Point	Distance	21.04	-0.500	0.500	21.130	0.087	Good
E11	Cylinder Outer Diameter	Line	Point	Distance	29.02	-0.500	0.500	28.706	-0.313	Good
E12	Square Base	Line	Point	Distance	150.40	-0.500	0.500	150.295	-0.108	Good
EE1	Triangular Hole	Line	Point	Distance	5.81	-0.500	0.500	5.662	-0.146	Good
EE2	Thin Walls	Line	Point	Distance	3.77	-0.500	0.500	3.790	0.018	Good
EE3	Thin Walls	Line	Point	Distance	2.38	-0.500	0.500	2.140	-0.244	Good
AA1	Wedge X-direction	Line	Line	Angularity	60	-0.500	0.500	61.392	1.392	High
AA2	Wedge X-direction	Line	Line	Angularity	75	-0.500	0.500	75.899	0.899	High
AA3	Wedge X-direction	Line	Line	Angularity	75	-0.500	0.500	73.841	-1.159	Low

BB1	Wedge Y-direction	Line	Line	Line	75	-0.500	0.500	75.031	0.031	Good
BB2	Wedge Y-direction	Line	Line	Line	60	-0.500	0.500	59.825	-0.175	Good
BB3	Wedge Y-direction	Line	Line	Line	75	-0.500	0.500	75.342	0.342	Good
CC1	Pyramid	Line	Line	Line	106.7	-0.500	0.500	108.497	1.797	High
CC2	Pyramid	Line	Line	Line	106.7	-0.500	0.500	106.434	-0.266	Good
DD1	Pyramid	Line	Line	Line	111.8	-0.500	0.500	111.034	-0.766	Low
DD2	Pyramid	Line	Line	Line	111.8	-0.500	0.500	113.738	1.938	High
T1	Triangular Hole	Line	Line	Line		-0.500	0.500	0.144	0.144	Good
T2	Cylinder Hole/ Hollow Cylinder	Outer Circle	Outer Circle	Inner Circle		-0.500	0.500	0.211	0.211	Good
T3	Cylinder Hole/ Hollow Cylinder	Outer Circle	Outer Circle	Inner Circle		-0.500	0.500	0.213	0.213	Good
T4	Cylinder Hole/ Hollow Cylinder	Outer Circle	Outer Circle	Inner Circle		-0.500	0.500	0.090	0.090	Good
T5	Square Base	Plane	Plane	Bottom Side		-0.500	0.500	1.187	1.187	High
T6	Square Base	Left_Side	Left_Side	Bottom Side		-0.500	0.500	0.209	0.209	Good
T7	Square Base	Top_Side	Top_Side	Right Side		-0.500	0.500	0.187	0.187	Good
T8	Square Base	Left_Side	Left_Side	Right Side		-0.500	0.500	0.306	0.306	Good
T9	Square Base	Top_Side	Top_Side	Bottom Side		-0.500	0.500	0.090	0.090	Good
T10	Thin Walls	Line	Line	Line		-0.500	0.500	0.104	0.104	Good
T11	Thin Walls	Line	Line	Line		-0.500	0.500	0.332	0.332	Good
T12	Thin Walls	Line	Line	Line		-0.500	0.500	0.444	0.444	Good
T13	Thin Walls	Line	Line	Line		-0.500	0.500	0.517	0.517	High
T14	Cube's 2,3,1	Cube231	Cube231			-0.500	0.500	0.032	0.032	Good
T15	Cube's 1,4, RecProtr	Cube14Rec	Cube14Rec			-0.500	0.500	0.262	0.262	Good
T16	Rectangular Protrusion Outer	RecP2	RecP2	RecP1		-0.500	0.500	0.521	0.521	High
T17	Rectangular Protrusion Inner	RecP4	RecP4	RecP3		-0.500	0.500	1.146	1.146	High
T18	Rectangular Hole Outer	RecH4	RecH4	RecH3		-0.500	0.500	2.215	2.215	High
T19	Rectangular Hole Inner	RecH1	RecH1	RecH2		-0.500	0.500	0.075	0.075	Good

T23	Cone	Actual Cone Axis	Cone	Symmetry tol. axis element	-0.500	0.500	0.066	0.066	Good
T24	Cone	Cone Bottom Circle	Cone	Circular runout	-0.500	0.500	0.407	0.407	Good
T29	Cone	plane_2	Cone	Axial runout	-0.500	0.500	3.655	3.655	High
T31	Cone	Cone	plane_2	Symmetry tol. axis element	-0.500	0.500	0.483	0.483	Good
T32	Cone	Cone Bottom Circle	Cone	Symmetry tol. point element	-0.500	0.500	0.016	0.016	Good
T33	Cone	Cone	plane_2	Angularity	-0.500	0.500	0.026	0.026	Good
T36	Cone	Cone	Actual Cone Axis	Coaxiality	-0.500	0.500	0.066	0.066	Good
T37	Cone	Cone_Bottom_Circle	Actual Cone Axis	Circular runout	-0.500	0.500	0.389	0.389	Good
T38	Sphere	Sphere Bottom Circle	Sphere Axis	Circular runout	-0.500	0.500	1.224	1.224	High
T39	Sphere	Sphere Bottom Circle	Actual Sphere Axis	Circular runout	-0.500	0.500	0.363	0.363	High
T41	Sphere	plane_2	Actual Sphere Axis	Axial runout	-0.500	0.500	5.850	5.850	Good
T42	Sphere	plane_2	Sphere	Symmetry tol. plane element	-0.500	0.500	3.999	3.999	High
T47	Sphere	Sphere Bottom Circle	Sphere	Symmetry tol. point element	-0.500	0.500	0.091	0.091	High
T50	Sphere	plane_2	Actual Sphere Axis	Perpendicularity	-0.500	0.500	1.438	1.438	Good
T52	Sphere	Sphere	Sphere Axis	Concentricity	-0.500	0.500	0.173	0.173	High
T54	Dome	Dome Bottom Circle	Actual Dome axis	Circular runout	-0.500	0.500	0.320	0.320	Good
T56	Dome	Dome Upper Circle	Actual Dome axis	Circular runout	-0.500	0.500	0.492	0.492	Good

T58	Dome	plane_2	Actual Dome axis	Axial runout	-0.500	0.500	1.033	1.033	High
T65	Dome	Dome Bottom Circle	Dome Upper Circle	Symmetry tol. point element	-0.500	0.500	0.098	0.098	Good
T67	Dome	plane_2	Actual Dome axis	Perpendicularity	-0.500	0.500	0.207	0.207	Good
T69	Dome	Dome Upper Circle	Dome Bottom Circle	Concentricity	-0.500	0.500	0.143	0.143	Good
T71	Sinkhole	Sinkhole Upper Circle	Actual Sinkhole Axis	Circular runout	-0.500	0.500	0.289	0.289	Good
T73	Sinkhole	Sinkhole Bottom Circle	Actual Sinkhole Axis	Circular runout	-0.500	0.500	0.113	0.113	Good
T82	Sinkhole	Sinkhole Bottom Circle	Sinkhole Bottom Circle	Symmetry tol. point element	-0.500	0.500	0.398	0.398	Good
T84	Sinkhole	plane_2	Actual Sinkhole Axis	Perpendicularity	-0.500	0.500	1.687	1.687	High
T86	Sinkhole	Sinkhole Bottom Circle	Sinkhole Lower Circle	Concentricity	-0.500	0.500	0.426	0.426	Good

## Feature Tolerances – SLS Aluminium Casting

Feature Tolerances - Aluminium Casting (SLS 4) 3mm										
Tolerance No.	Feature	Tol,ElemName	Compared to	Type of Tolerance	Spec.	Lower Tol.	Upper Tol.	Actual	Tol. Deviation	Result
A1	Square Base	Line	Point	Distance	60.03	-0.500	0.500	60.557	0.523	High
A2	Pattern	Line	Point	Distance	70.76	-0.500	0.500	70.975	0.210	Good
A3	Pattern	Line	Point	Distance	2.08	-0.500	0.500	1.972	-0.105	Good
A4	Rectangular Protrusion	Line	Point	Distance	25.16	-0.500	0.500	24.832	-0.327	Good
A5	Rectangular Protrusion	Line	Point	Distance	8.39	-0.500	0.500	8.154	-0.234	Good
A6	Rectangular Protrusion	Line	Point	Distance	8.04	-0.500	0.500	8.180	0.145	Good
A7	Pattern	Line	Point	Distance	8.12	-0.500	0.500	8.121	-0.001	Good
A8	Wedge X	Line	Point	Distance	13.28	-0.500	0.500	12.592	-0.687	Low
A9	Cube 1	Line	Point	Distance	8.02	-0.500	0.500	8.366	0.350	Good
A10	Cube 1	Line	Point	Distance	8.21	-0.500	0.500	8.392	0.187	Good
A11	Cube 1	Line	Point	Distance	8.31	-0.500	0.500	8.194	-0.114	Good
A12	Rectangular Hole	Line	Point	Distance	24.89	-0.500	0.500	25.350	0.458	Good
A13	Rectangular Hole	Line	Point	Distance	8.39	-0.500	0.500	8.600	0.215	Good
A14	Cube 2	Line	Point	Distance	8.49	-0.500	0.500	7.799	-0.689	Low
A15	Cube 2	Line	Point	Distance	7.98	-0.500	0.500	8.338	0.359	Good
A16	Pattern	Line	Point	Distance	1.97	-0.500	0.500	2.324	0.358	Good
B1	Square Base	Line	Point	Distance	150.15	-0.500	0.500	150.448	0.295	Good
B2	Cube 1	Line	Point	Distance	8.22	-0.500	0.500	8.235	0.014	Good
C1	Rectangular Protrusion	Line	Point	Distance	8.52	-0.500	0.500	8.196	-0.325	Good
C2	Pattern	Line	Point	Distance	0.86	-0.500	0.500	1.663	0.805	High
C3	Rectangular Protrusion	Line	Point	Distance	24.51	-0.500	0.500	24.729	0.221	Good
C4	Square Base	Line	Point	Distance	150.15	-0.500	0.500	150.448	0.295	Good
C5	Wedge X	Line	Point	Distance	24.77	-0.500	0.500	24.847	0.075	Good

C6	Cube 1	Line	Point	Distance	8.15	-0.500	0.500	8.343	0.196	Good
CC3	Cube 1	Line	Point	Distance	8.31	-0.500	0.500	8.194	-0.114	Good
CC4	Cube 1	Line	Point	Distance	8.21	-0.500	0.500	8.392	0.187	Good
CC5	Cylinder Depth	Line	Point	Distance	16.71	-0.500	0.500	16.668	-0.041	Good
D1	Square Base Depth	Line	Point	Distance	29.33	-0.500	0.500	30.948	1.618	High
D2	Cube 3	Line	Point	Distance	3.92	-0.500	0.500	4.000	0.085	Good
D3	Cube 3	Line	Point	Distance	8.59	-0.500	0.500	8.255	-0.333	Good
D4	Cube 2	Line	Point	Distance	8.15	-0.500	0.500	8.235	0.088	Good
D5	Cube 2	Line	Point	Distance	8.58	-0.500	0.500	8.176	-0.405	Good
E1	Square Base	Line	Point	Distance	150.81	-0.500	0.500	150.612	-0.193	Good
E2	Wedge Y	Line	Point	Distance	25.49	-0.500	0.500	24.769	-0.723	Low
E3	Wedge Y	Line	Point	Distance	12.87	-0.500	0.500	12.380	-0.487	Good
E4	Wedge Y	Line	Point	Distance	6.95	-0.500	0.500	6.597	-0.349	Good
E5	Cube 4	Line	Point	Distance	8.13	-0.500	0.500	8.200	0.072	Good
E6	Rectangular Hole	Line	Point	Distance	8.61	-0.500	0.500	8.807	0.195	Good
E7	Rectangular Hole	Line	Point	Distance	25.20	-0.500	0.500	25.313	0.109	Good
E8	Cube 3	Line	Point	Distance	8.19	-0.500	0.500	8.350	0.164	Good
E9	Cube 3	Line	Point	Distance	8.67	-0.500	0.500	8.158	-0.514	Low
E10	Cylinder Inner Diameter	Line	Point	Distance	21.04	-0.500	0.500	20.921	-0.122	Good
E11	Cylinder Outer Diameter	Line	Point	Distance	29.02	-0.500	0.500	29.054	0.035	Good
E12	Square Base	Line	Point	Distance	150.40	-0.500	0.500	150.614	0.211	Good
EE1	Triangular Hole	Line	Point	Distance	5.81	-0.500	0.500	5.829	0.021	Good
EE2	Thin Walls	Line	Point	Distance	3.77	-0.500	0.500	4.013	0.241	Good
EE3	Thin Walls	Line	Point	Distance	2.38	-0.500	0.500	2.461	0.077	Good
AA1	Wedge X-direction	Line	Line	Angularity	60	-0.500	0.500	59.834	-0.166	Good
AA2	Wedge X-direction	Line	Line	Angularity	75	-0.500	0.500	74.670	-0.330	Good
AA3	Wedge X-direction	Line	Line	Angularity	75	-0.500	0.500	75.629	0.629	High
BB1	Wedge Y-direction	Line	Line	Angularity	75	-0.500	0.500	75.056	0.056	Good
BB2	Wedge Y-direction	Line	Line	Angularity	60	-0.500	0.500	60.268	0.268	Good



T24	Cone	Cone Bottom Circle	Cone	Circular runout		-0.500	0.500	0.077	0.077	Good
T29	Cone	plane_2	Cone	Axial runout		-0.500	0.500	1.512	1.512	High
T31	Cone	Cone	plane_2	Symmetry tol. axis element		-0.500	0.500	0.342	0.342	Good
T32	Cone	Cone Bottom Circle	Cone	Symmetry tol. point element		-0.500	0.500	0.016	0.016	Good
T33	Cone	Cone	plane_2	Angularity		-0.500	0.500	0.028	0.028	Good
T36	Cone	Cone	Actual Cone Axis	Coaxiality		-0.500	0.500	0.052	0.052	Good
T37	Cone	Cone_Bottom_Circle	Actual Cone Axis	Circular runout		-0.500	0.500	0.070	0.070	Good
T38	Sphere	Sphere Bottom Circle	Sphere Axis	Circular runout		-0.500	0.500	0.708	0.708	High
T39	Sphere	Sphere Bottom Circle	Actual Sphere Axis	Circular runout		-0.500	0.500	0.028	0.028	Good
T41	Sphere	plane_2	Actual Sphere Axis	Axial runout		-0.500	0.500	1.836	1.836	High
T42	Sphere	Sphere Bottom Circle	Sphere	Symmetry tol. plane element		-0.500	0.500	4.313	4.313	High
T47	Sphere	plane_2	Sphere	Symmetry tol. point element		-0.500	0.500	0.002	0.002	Good
T50	Sphere	Sphere	Actual Sphere Axis	Perpendicularity		-0.500	0.500	0.789	0.789	High
T52	Sphere	Sphere	Sphere Bottom Circle	Concentricity		-0.500	0.500	0.082	0.082	Good
T54	Dome	Dome Bottom Circle	Actual Dome axis	Circular runout		-0.500	0.500	0.085	0.085	Good
T56	Dome	Dome Upper Circle	Actual Dome axis	Circular runout		-0.500	0.500	0.040	0.040	Good
T58	Dome	plane_2	Actual Dome axis	Axial runout		-0.500	0.500	1.247	1.247	High

T65	Dome	Dome Bottom Circle	Dome Upper Circle	Symmetry tol. point element	-0.500	0.500	0.161	0.161	Good
T67	Dome	plane_2	Actual Dome axis	Perpendicularity	-0.500	0.500	0.249	0.249	Good
T69	Dome	Dome Upper Circle	Dome Bottom Circle	Concentricity	-0.500	0.500	0.172	0.172	Good
T71	Sinkhole	Sinkhole Upper Circle	Actual Sinkhole Axis	Circular runout	-0.500	0.500	0.140	0.140	Good
T73	Sinkhole	Sinkhole Bottom Circle	Actual Sinkhole Axis	Circular runout	-0.500	0.500	0.032	0.032	Good
T82	Sinkhole	Sinkhole Bottom Circle	Sinkhole Bottom Circle	Symmetry tol. point element	-0.500	0.500	0.012	0.012	Good
T84	Sinkhole	plane_2	Actual Sinkhole Axis	Perpendicularity	-0.500	0.500	0.126	0.126	Good
T86	Sinkhole	Sinkhole Bottom Circle	Sinkhole Lower Circle	Concentricity	-0.500	0.500	0.014	0.014	Good

## Feature Tolerances – ThermoJet Aluminium Casting

Feature Tolerances - Aluminium Casting (ThermoJet 1) 3mm										
Tolerance No.	Feature	Tol.ElemName	Compared to	Type of Tolerance	Spec.	Lower Tol.	Upper Tol.	Actual	Tol. Deviation	Result
A1	Square Base	Line	Point	Distance	60.03	-0.500	0.500	60.390	0.356	Good
A2	Pattern	Line	Point	Distance	70.76	-0.500	0.500	71.174	0.409	Good
A3	Pattern	Line	Point	Distance	2.08	-0.500	0.500	2.081	0.004	Good
A4	Rectangular Protrusion	Line	Point	Distance	25.16	-0.500	0.500	24.878	-0.281	Good
A5	Rectangular Protrusion	Line	Point	Distance	8.39	-0.500	0.500	8.272	-0.116	Good
A6	Rectangular Protrusion	Line	Point	Distance	8.04	-0.500	0.500	8.035	0.000	Good
A7	Pattern	Line	Point	Distance	8.12	-0.500	0.500	8.281	0.159	Good
A8	Wedge X	Line	Point	Distance	13.28	-0.500	0.500	12.559	-0.720	Low
A9	Cube 1	Line	Point	Distance	8.02	-0.500	0.500	8.079	0.063	Good
A10	Cube 1	Line	Point	Distance	8.21	-0.500	0.500	8.318	0.113	Good
A11	Cube 1	Line	Point	Distance	8.31	-0.500	0.500	8.288	-0.020	Good
A12	Rectangular Hole	Line	Point	Distance	24.89	-0.500	0.500	24.608	-0.284	Good
A13	Rectangular Hole	Line	Point	Distance	8.39	-0.500	0.500	8.358	-0.027	Good
A14	Cube 2	Line	Point	Distance	8.49	-0.500	0.500	8.459	-0.029	Good
A15	Cube 2	Line	Point	Distance	7.98	-0.500	0.500	8.309	0.330	Good
A16	Pattern	Line	Point	Distance	1.97	-0.500	0.500	2.550	0.584	High
B1	Square Base	Line	Point	Distance	150.15	-0.500	0.500	151.153	1.000	High
B2	Cube 1	Line	Point	Distance	8.22	-0.500	0.500	8.516	0.295	Good
C1	Rectangular Protrusion	Line	Point	Distance	8.52	-0.500	0.500	8.280	-0.241	Good
C2	Pattern	Line	Point	Distance	0.86	-0.500	0.500	1.953	1.095	High
C3	Rectangular Protrusion	Line	Point	Distance	24.51	-0.500	0.500	24.874	0.366	Good
C4	Square Base	Line	Point	Distance	150.15	-0.500	0.500	151.153	1.000	High
C5	Wedge X	Line	Point	Distance	24.77	-0.500	0.500	24.991	0.219	Good
C6	Cube 1	Line	Point	Distance	8.15	-0.500	0.500	8.387	0.240	Good
CC3	Cube 1	Line	Point	Distance	8.31	-0.500	0.500	8.288	-0.020	Good
CC4	Cube 1	Line	Point	Distance	8.21	-0.500	0.500	8.318	0.113	Good
CC5	Cylinder Depth	Line	Point	Distance	16.71	-0.500	0.500	16.591	-0.118	Good
D1	Square Base Depth	Line	Point	Distance	29.33	-0.500	0.500	29.106	-0.224	Good
D2	Cube 3	Line	Point	Distance	3.92	-0.500	0.500	4.413	0.498	Good
D3	Cube 3	Line	Point	Distance	8.59	-0.500	0.500	8.367	-0.221	Good

D4	Cube 2	Line	Point	Distance	8.15	-0.500	0.500	8.316	0.169	Good
D5	Cube 2	Line	Point	Distance	8.58	-0.500	0.500	8.193	-0.388	Good
E1	Square Base	Line	Point	Distance	150.81	-0.500	0.500	151.088	0.283	Good
E2	Wedge Y	Line	Point	Distance	25.49	-0.500	0.500	25.034	-0.458	Good
E3	Wedge Y	Line	Point	Distance	12.87	-0.500	0.500	12.238	-0.629	Low
E4	Wedge Y	Line	Point	Distance	6.95	-0.500	0.500	7.438	0.492	Good
E5	Cube 4	Line	Point	Distance	8.13	-0.500	0.500	8.207	0.079	Good
E6	Rectangular Hole	Line	Point	Distance	8.61	-0.500	0.500	7.780	-0.832	Low
E7	Rectangular Hole	Line	Point	Distance	25.20	-0.500	0.500	25.178	-0.026	Good
E8	Cube 3	Line	Point	Distance	8.19	-0.500	0.500	8.372	0.186	Good
E9	Cube 3	Line	Point	Distance	8.67	-0.500	0.500	8.431	-0.241	Good
E10	Cylinder Inner Diameter	Line	Point	Distance	21.04	-0.500	0.500	20.940	-0.103	Good
E11	Cylinder Outer Diameter	Line	Point	Distance	29.02	-0.500	0.500	29.279	0.260	Good
E12	Square Base	Line	Point	Distance	150.40	-0.500	0.500	151.014	0.611	High
EE1	Triangular Hole	Line	Point	Distance	5.81	-0.500	0.500	5.688	-0.120	Good
EE2	Thin Walls	Line	Point	Distance	3.77	-0.500	0.500	4.102	0.330	Good
EE3	Thin Walls	Line	Point	Distance	2.38	-0.500	0.500	2.597	0.213	Good
AA1	Wedge X-direction	Line	Line	Angularity	60	-0.500	0.500	59.468	-0.532	Low
AA2	Wedge X-direction	Line	Line	Angularity	75	-0.500	0.500	73.539	-1.461	Low
AA3	Wedge X-direction	Line	Line	Angularity	75	-0.500	0.500	77.783	2.783	High
BB1	Wedge Y-direction	Line	Line	Angularity	75	-0.500	0.500	75.212	0.212	Good
BB2	Wedge Y-direction	Line	Line	Angularity	60	-0.500	0.500	60.716	0.716	High
BB3	Wedge Y-direction	Line	Line	Angularity	75	-0.500	0.500	75.915	0.915	High
CC1	Pyramid	Line	Line	Angularity	106.7	-0.500	0.500	103.945	-2.755	Low
CC2	Pyramid	Line	Line	Angularity	106.7	-0.500	0.500	107.994	1.294	High
DD1	Pyramid	Line	Line	Angularity	111.8	-0.500	0.500	110.991	-0.809	Low
DD2	Pyramid	Line	Line	Angularity	111.8	-0.500	0.500	111.740	-0.060	Good
T1	Triangular Hole	Line	Line	Perpendicularity		-0.500	0.500	0.023	0.023	Good
T2	Cylinder Hole/ Hollow	Outer Circle	Inner Circle	Circularity		-0.500	0.500	0.040	0.040	Good
T3	Cylinder Hole/ Hollow	Outer Circle	Inner Circle	Concentricity		-0.500	0.500	0.097	0.097	Good
T4	Cylinder Hole/ Hollow	Outer Circle	Inner Circle	Circularity		-0.500	0.500	0.121	0.121	Good
T5	Square Base	Plane		Flatness		-0.500	0.500	0.368	0.368	Good
T6	Square Base	Left_Side	Bottom Side	Perpendicularity		-0.500	0.500	0.625	0.625	High

T7	Square Base	Top_Side	Right Side	Perpendicularity	-0.500	0.500	0.048	Good
T8	Square Base	Left_Side	Right Side	Parallelism	-0.500	0.500	0.692	High
T9	Square Base	Top_Side	Bottom Side	Parallelism	-0.500	0.500	0.018	Good
T10	Thin Walls	Line	Line	Parallelism	-0.500	0.500	0.037	Good
T11	Thin Walls	Line	Line	Parallelism	-0.500	0.500	0.144	Good
T12	Thin Walls	Line	Line	Thickness	-0.500	0.500	0.018	Good
T13	Thin Walls	Line	Line	Thickness	-0.500	0.500	0.034	Good
T14	Cube's 2,3,1	Cube231		Straightness	-0.500	0.500	0.140	Good
T15	Cube's 1,4, RecProtr	Cube14Rec		Straightness	-0.500	0.500	0.176	Good
T16	Rectangular Protrusion	RecP2	RecP1	Perpendicularity	-0.500	0.500	0.163	Good
T17	Rectangular Protrusion	RecP4	RecP3	Perpendicularity	-0.500	0.500	0.344	Good
T18	Rectangular Hole Outer	RecH4	RecH3	Perpendicularity	-0.500	0.500	2.418	High
T19	Rectangular Hole Inner	RecH1	RecH2	Perpendicularity	-0.500	0.500	6.709	High
T23	Cone	Actual Cone Axis	Cone	Symmetry tol. axis element	-0.500	0.500	0.200	Good
T24	Cone	Cone Bottom Circle	Cone	Circular runout	-0.500	0.500	0.201	Good
T29	Cone	plane_2	Cone	Axial runout	-0.500	0.500	2.804	High
T31	Cone	Cone	plane_2	Symmetry tol. axis element	-0.500	0.500	0.025	Good
T32	Cone	Cone Bottom Circle	Cone	Symmetry tol. point element	-0.500	0.500	0.093	Good
T33	Cone	Cone	plane_2	Angularity	-0.500	0.500	0.025	Good
T36	Cone	Cone	Actual Cone Axis	Coaxiality	-0.500	0.500	0.202	Good
T37	Cone	Cone_Bottom_Circle	Actual Cone Axis	Circular runout	-0.500	0.500	0.184	Good
T38	Sphere	Sphere Bottom Circle	Sphere Axis	Circular runout	-0.500	0.500	0.599	High
T39	Sphere	Sphere Bottom Circle	Actual Sphere Axis	Circular runout	-0.500	0.500	0.206	Good
T41	Sphere	plane_2	Actual Sphere Axis	Axial runout	-0.500	0.500	6.719	High
T42	Sphere	plane_2	Sphere	Symmetry tol. plane element	-0.500	0.500	2.647	High
T47	Sphere	Sphere Bottom Circle	Sphere	Symmetry tol. point element	-0.500	0.500	0.239	Good
T50	Sphere	plane_2	Actual Sphere Axis	Perpendicularity	-0.500	0.500	1.373	High
T52	Sphere	Sphere	Sphere Bottom Cir.	Concentricity	-0.500	0.500	0.240	Good
T54	Dome	Dome Bottom Circle	Actual Dome axis	Circular runout	-0.500	0.500	0.363	Good
T56	Dome	Dome Upper Circle	Actual Dome axis	Circular runout	-0.500	0.500	0.034	Good
T58	Dome	plane_2	Actual Dome axis	Axial runout	-0.500	0.500	1.913	High

T65	Dome	Dome Bottom Circle	Dome Upper Circle	Symmetry tol. point element	-0.500	0.500	0.163	0.163	Good
T67	Dome	plane_2	Actual Dome axis	Perpendicularity	-0.500	0.500	0.383	0.383	Good
T69	Dome	Dome Upper Circle	Dome Bottom Circle	Concentricity	-0.500	0.500	0.196	0.196	Good
T71	Sinkhole	Sinkhole Upper Circle	Actual Sinkhole Axis	Circular runout	-0.500	0.500	0.245	0.245	Good
T73	Sinkhole	Sinkhole Bottom Circle	Actual Sinkhole Axis	Circular runout	-0.500	0.500	0.483	0.483	Good
T82	Sinkhole	Sinkhole Bottom Circle	Sinkhole Bottom Circle	Symmetry tol. point element	-0.500	0.500	1.710	1.710	High
T84	Sinkhole	plane_2	Actual Sinkhole Axis	Perpendicularity	-0.500	0.500	6.295	6.295	High
T86	Sinkhole	Sinkhole Bottom Circle	Sinkhole Lower Circle	Concentricity	-0.500	0.500	1.890	1.890	High

*Appendix C      Aluminium Castings -  
Statistical CMM Raw  
Data (3D-Tol Data)*

### 3D-Tol Data from CMM for 3DP Aluminium Casting

MEAS X	MEAS Y	MEAS Z	Pattern X	Pattern Y	Pattern Z	DIF X	DIF Y	DIF Z	TOT DIF
53.793	58.634	-5.293	53.553	58.607	-5.199	0.240	0.027	-0.094	0.259
37.248	58.715	-5.354	37.097	58.701	-5.257	0.151	0.014	-0.097	0.180
20.703	58.751	-5.418	20.643	58.770	-5.314	0.060	-0.019	-0.104	0.121
4.159	58.831	-5.482	4.190	58.777	-5.373	-0.031	0.054	-0.109	0.126
-12.384	58.818	-5.545	-12.259	58.721	-5.431	-0.125	0.097	-0.114	0.195
-28.930	58.849	-5.608	-28.713	58.752	-5.489	-0.217	0.097	-0.119	0.266
-45.475	58.697	-5.671	-45.165	58.580	-5.546	-0.310	0.117	-0.125	0.354
-62.019	58.488	-5.734	-61.616	58.435	-5.603	-0.403	0.053	-0.131	0.427
-79.623	40.729	-5.821	-79.429	40.501	-5.681	-0.194	0.228	-0.140	0.330
-79.429	24.184	-5.829	-79.487	24.049	-5.687	0.058	0.135	-0.142	0.204
-79.603	7.639	-5.840	-79.531	7.596	-5.693	-0.072	0.043	-0.147	0.169
-79.583	-8.905	-5.849	-79.531	-8.857	-5.699	-0.052	-0.048	-0.150	0.166
-79.546	-25.450	-5.860	-79.504	-25.310	-5.705	-0.042	-0.140	-0.155	0.213
-79.567	-41.996	-5.870	-79.501	-41.762	-5.711	-0.066	-0.234	-0.159	0.290
-79.371	-58.539	-5.879	-79.378	-58.215	-5.716	0.007	-0.324	-0.163	0.363
-79.326	-75.085	-5.889	-79.279	-74.667	-5.722	-0.047	-0.418	-0.167	0.453
-61.994	-91.970	-5.832	-61.734	-92.162	-5.663	-0.260	0.192	-0.169	0.364
-45.450	-92.053	-5.768	-45.282	-92.267	-5.604	-0.168	0.214	-0.164	0.318
-28.906	-91.991	-5.704	-28.830	-92.255	-5.545	-0.076	0.264	-0.159	0.318
-12.361	-92.249	-5.642	-12.376	-92.466	-5.487	0.015	0.217	-0.155	0.267
4.183	-92.243	-5.577	4.075	-92.476	-5.430	0.108	0.233	-0.147	0.296
20.728	-92.309	-5.514	20.528	-92.437	-5.372	0.200	0.128	-0.142	0.277
37.273	-92.086	-5.451	36.980	-92.246	-5.313	0.293	0.160	-0.138	0.361
53.818	-92.163	-5.388	53.433	-92.232	-5.257	0.385	0.069	-0.131	0.413
70.515	-75.061	-5.307	70.866	-74.786	-5.183	-0.351	-0.275	-0.124	0.463
70.509	-58.516	-5.297	70.966	-58.332	-5.174	-0.457	-0.184	-0.123	0.507
70.810	-41.971	-5.285	71.020	-41.879	-5.167	-0.210	-0.092	-0.118	0.258
70.829	-25.426	-5.275	71.011	-25.427	-5.161	-0.182	0.001	-0.114	0.215
70.947	-8.882	-5.265	71.116	-8.974	-5.155	-0.169	0.092	-0.110	0.221
70.926	7.663	-5.255	71.115	7.477	-5.150	-0.189	0.186	-0.105	0.285
70.969	24.208	-5.245	71.113	23.929	-5.144	-0.144	0.279	-0.101	0.330
70.749	40.752	-5.236	70.985	40.382	-5.138	-0.236	0.370	-0.098	0.450
-69.818	43.415	8.301	-69.381	43.166	8.593	-0.437	0.249	-0.292	0.581
-64.768	43.413	8.389	-64.361	43.162	8.582	-0.407	0.251	-0.193	0.516
-64.770	48.465	8.475	-64.357	48.184	8.665	-0.413	0.281	-0.190	0.535
-69.820	48.465	8.373	-69.378	48.186	8.571	-0.442	0.279	-0.198	0.558
-67.688	46.060	8.386	-67.260	45.795	8.577	-0.428	0.265	-0.191	0.538
-71.666	42.469	6.839	-71.131	43.169	6.903	-0.535	-0.700	-0.064	0.884
-71.285	48.466	6.842	-71.228	48.193	6.908	-0.057	0.273	-0.066	0.287
-69.809	50.476	6.854	-69.366	50.322	6.919	-0.443	0.154	-0.065	0.474
-64.758	50.449	6.874	-64.344	50.305	6.939	-0.414	0.144	-0.065	0.443
-64.759	42.433	6.865	-64.352	41.937	6.931	-0.407	0.496	-0.066	0.645
-69.808	41.945	7.816	-69.373	42.077	6.914	-0.435	-0.132	0.902	1.010
-63.344	48.467	6.879	-63.072	48.184	6.945	-0.272	0.283	-0.066	0.398
-63.390	43.416	6.877	-63.174	43.162	6.943	-0.216	0.254	-0.066	0.340

-64.743	-14.657	4.080	-64.389	-14.587	4.047	-0.354	-0.070	0.033	0.362
-69.793	-14.658	4.047	-69.413	-14.585	4.155	-0.380	-0.073	-0.108	0.401
-69.793	-19.709	4.130	-69.416	-19.605	4.159	-0.377	-0.104	-0.029	0.392
-64.742	-19.709	4.126	-64.393	-19.609	4.093	-0.349	-0.100	0.033	0.364
-67.914	-17.084	4.106	-67.546	-16.997	4.108	-0.368	-0.087	-0.002	0.378
-69.785	-12.525	3.450	-69.403	-12.444	3.549	-0.382	-0.081	-0.099	0.402
-64.735	-12.640	3.471	-64.381	-12.511	4.153	-0.354	-0.129	-0.682	0.779
-63.254	-14.656	3.474	-62.795	-14.587	4.202	-0.459	-0.069	-0.728	0.864
-63.147	-19.707	4.235	-62.815	-19.611	4.221	-0.332	-0.096	0.014	0.346
-64.736	-20.980	4.309	-64.389	-20.829	3.561	-0.347	-0.151	0.748	0.838
-69.787	-20.997	4.279	-69.412	-20.902	3.544	-0.375	-0.095	0.735	0.830
-71.490	-19.706	4.298	-71.247	-19.602	3.534	-0.243	-0.104	0.764	0.808
-71.530	-14.656	4.223	-71.272	-14.580	3.538	-0.258	-0.076	0.685	0.736
-64.750	-77.785	8.595	-64.456	-77.363	8.668	-0.294	-0.422	-0.073	0.520
-69.800	-77.786	8.440	-69.479	-77.361	8.625	-0.321	-0.425	-0.185	0.564
-69.799	-82.839	8.465	-69.482	-82.383	8.646	-0.317	-0.456	-0.181	0.584
-64.748	-82.838	8.492	-64.460	-82.385	8.642	-0.288	-0.453	-0.150	0.558
-69.787	-75.444	6.779	-69.465	-75.262	6.875	-0.322	-0.182	-0.096	0.382
-64.735	-75.292	6.799	-64.442	-75.098	6.894	-0.293	-0.194	-0.095	0.364
-63.242	-77.784	6.804	-62.941	-77.360	6.900	-0.301	-0.424	-0.096	0.529
-63.201	-82.835	6.801	-62.871	-82.385	6.898	-0.330	-0.450	-0.097	0.567
-64.739	-83.623	6.788	-64.451	-83.702	6.885	-0.288	0.079	-0.097	0.314
-69.789	-83.600	6.769	-69.473	-83.721	6.869	-0.316	0.121	-0.100	0.353
-71.639	-83.797	6.764	-71.030	-82.377	6.859	-0.609	-1.420	-0.095	1.548
-71.151	-77.783	6.767	-71.270	-77.356	6.864	0.119	-0.427	-0.097	0.454
-2.469	43.428	4.206	-2.410	43.115	4.174	-0.059	0.313	0.032	0.321
2.582	43.428	4.209	2.615	43.112	4.161	-0.033	0.316	0.048	0.322
2.581	48.478	4.264	2.617	48.131	4.346	-0.036	0.347	-0.082	0.358
-2.470	48.477	4.233	-2.405	48.135	4.310	-0.065	0.342	-0.077	0.356
-0.631	46.462	4.218	-0.576	46.131	4.229	-0.055	0.331	-0.011	0.336
-4.166	43.432	2.466	-4.293	43.118	2.537	0.127	0.314	-0.071	0.346
-4.275	48.484	2.471	-4.424	48.139	2.541	0.149	0.345	-0.070	0.382
2.592	42.330	2.492	2.622	41.931	2.564	-0.030	0.399	-0.072	0.406
-2.458	42.351	2.473	-2.399	41.899	2.546	-0.059	0.452	-0.073	0.461
3.650	48.480	2.507	3.911	48.133	2.578	-0.261	0.347	-0.071	0.440
4.336	42.481	2.504	3.984	43.111	2.575	0.352	-0.630	-0.071	0.725
-2.456	50.692	2.481	-2.391	50.698	2.552	-0.065	-0.006	-0.071	0.097
2.595	50.548	2.502	2.631	50.375	2.570	-0.036	0.173	-0.068	0.189
-65.042	36.210	-1.133	-64.680	36.029	-1.018	-0.362	0.181	-0.115	0.421
-54.250	46.847	-1.084	-54.058	46.719	-0.977	-0.192	0.128	-0.107	0.254
-46.533	46.901	-1.061	-46.360	46.476	-0.955	-0.173	0.425	-0.106	0.471
-36.111	35.900	-0.212	-35.759	35.773	-0.922	-0.352	0.127	0.710	0.803
-40.666	28.965	-0.213	-40.422	28.753	-0.153	-0.244	0.212	-0.060	0.329
-47.841	36.071	-0.180	-47.562	35.814	-0.107	-0.279	0.257	-0.073	0.386
-36.043	29.620	-1.410	-35.894	29.501	-1.304	-0.149	0.119	-0.106	0.218
-54.101	34.793	-1.094	-54.127	34.943	-0.987	0.026	-0.150	-0.107	0.186
-58.779	29.948	-1.116	-58.687	30.032	-1.004	-0.092	-0.084	-0.112	0.167
-65.324	29.257	-1.036	-64.871	29.143	-0.920	-0.453	0.114	-0.116	0.482
-61.307	33.217	-3.969	-60.931	33.014	-4.097	-0.376	0.203	0.128	0.446

-56.740	37.971	-3.917	-56.382	37.739	-4.131	-0.358	0.232	0.214	0.477
-50.245	43.376	-3.812	-49.920	43.107	-4.013	-0.325	0.269	0.201	0.467
-44.684	38.328	-3.856	-44.393	38.083	-4.131	-0.291	0.245	0.275	0.469
-40.008	33.522	-3.918	-39.748	33.298	-4.205	-0.260	0.224	0.287	0.448
49.711	42.292	6.460	49.480	42.028	6.496	0.231	0.264	-0.036	0.353
42.977	42.341	6.434	42.784	42.081	6.472	0.193	0.260	-0.038	0.325
54.429	29.970	6.470	54.357	29.677	6.507	0.072	0.293	-0.037	0.304
54.349	36.705	6.476	54.310	36.375	6.509	0.039	0.330	-0.033	0.334
58.855	25.851	5.992	58.558	25.141	6.030	0.297	0.710	-0.038	0.770
63.137	29.972	7.503	62.442	29.672	6.542	0.695	0.300	0.961	1.223
62.090	37.545	6.512	62.398	37.205	6.548	-0.308	0.340	-0.036	0.460
61.986	45.121	6.517	62.174	44.736	6.550	-0.188	0.385	-0.033	0.429
58.126	50.184	6.503	57.857	50.256	6.531	0.269	-0.072	-0.028	0.280
50.550	50.220	6.475	50.321	50.240	6.505	0.229	-0.020	-0.030	0.232
42.976	50.269	6.446	42.789	50.174	6.478	0.187	0.095	-0.032	0.212
37.718	45.909	5.697	37.501	45.545	5.736	0.217	0.364	-0.039	0.426
43.214	46.077	8.732	43.025	45.706	8.717	0.189	0.371	0.015	0.417
50.446	45.787	8.794	50.214	45.411	8.952	0.232	0.376	-0.158	0.470
58.418	45.456	8.824	58.141	45.076	8.878	0.277	0.380	-0.054	0.473
59.158	37.192	8.841	58.871	36.856	8.868	0.287	0.336	-0.027	0.443
59.037	30.347	8.655	58.744	30.049	8.856	0.293	0.298	-0.201	0.464
-30.894	49.063	16.912	-30.666	48.401	17.113	-0.228	0.662	-0.201	0.728
-30.875	46.012	11.973	-30.651	45.594	12.071	-0.224	0.418	-0.098	0.484
-30.855	43.300	6.837	-30.635	42.838	7.000	-0.220	0.462	-0.163	0.537
-30.836	40.447	1.783	-30.621	40.111	1.909	-0.215	0.336	-0.126	0.418
-27.047	40.432	1.804	-26.853	40.111	1.922	-0.194	0.321	-0.118	0.393
-27.068	43.299	6.856	-26.870	42.894	6.977	-0.198	0.405	-0.121	0.467
-27.086	46.030	11.978	-26.884	45.625	12.065	-0.202	0.405	-0.087	0.460
-27.108	48.894	17.026	-26.900	48.463	17.089	-0.208	0.431	-0.063	0.483
-23.319	49.047	16.951	-23.133	48.436	17.115	-0.186	0.611	-0.164	0.660
-23.300	46.151	11.921	-23.119	45.693	12.038	-0.181	0.458	-0.117	0.506
-23.280	43.354	6.837	-23.104	42.968	6.948	-0.176	0.386	-0.111	0.438
-23.260	40.491	1.786	-23.088	40.182	1.889	-0.172	0.309	-0.103	0.369
-16.948	45.735	2.025	-16.806	45.444	2.097	-0.142	0.291	-0.072	0.332
-16.977	47.682	9.584	-16.831	47.302	9.636	-0.146	0.380	-0.052	0.410
-17.007	49.841	17.084	-16.856	49.027	17.208	-0.151	0.814	-0.124	0.837
-11.956	50.141	17.539	-11.834	49.076	17.213	-0.122	1.065	0.326	1.120
-11.928	47.714	9.594	-11.810	47.190	9.682	-0.118	0.524	-0.088	0.545
-11.898	45.828	2.019	-11.785	45.497	2.100	-0.113	0.331	-0.081	0.359
-9.416	49.275	7.880	-8.492	48.936	7.927	-0.924	0.339	-0.047	0.985
-30.887	50.617	15.346	-30.658	50.599	15.437	-0.229	0.018	-0.091	0.247
-30.865	52.357	9.754	-30.638	52.192	9.835	-0.227	0.165	-0.081	0.292
-30.843	54.020	4.138	-30.618	53.870	4.260	-0.225	0.150	-0.122	0.297
-24.110	54.020	4.163	-23.920	54.077	4.340	-0.190	-0.057	-0.177	0.266
-24.132	52.513	9.822	-23.941	52.492	9.941	-0.191	0.021	-0.119	0.226
-24.154	50.799	15.421	-23.962	50.727	15.494	-0.192	0.072	-0.073	0.218
-17.418	50.921	15.480	-17.266	50.765	15.530	-0.152	0.156	-0.050	0.223
-17.397	52.522	9.849	-17.246	52.451	9.956	-0.151	0.071	-0.107	0.198
-17.375	54.053	4.197	-17.227	54.031	4.354	-0.148	0.022	-0.157	0.217

-10.644	53.839	4.166	-10.528	54.018	4.375	-0.116	-0.179	-0.209	0.299
-10.666	52.033	9.743	-10.550	52.225	9.920	-0.116	-0.192	-0.177	0.286
-10.688	50.854	15.486	-10.571	50.709	15.540	-0.117	0.145	-0.054	0.194
-33.114	48.612	9.926	-33.255	48.302	9.961	0.141	0.310	-0.035	0.343
5.254	-63.470	19.132	5.186	-63.194	19.130	0.068	-0.276	0.002	0.284
3.380	-63.466	12.058	3.355	-63.189	12.088	0.025	-0.277	-0.030	0.280
1.484	-63.462	4.991	1.462	-63.185	5.063	0.022	-0.277	-0.072	0.287
1.416	-70.197	5.007	1.422	-69.882	5.071	-0.006	-0.315	-0.064	0.322
3.310	-70.200	12.074	3.288	-69.885	12.104	0.022	-0.315	-0.030	0.318
5.211	-70.205	19.139	5.127	-69.888	19.143	0.084	-0.317	-0.004	0.328
5.239	-76.938	19.127	5.150	-76.585	19.133	0.089	-0.353	-0.006	0.364
3.305	-76.932	12.071	3.298	-76.580	12.097	0.007	-0.352	-0.026	0.353
1.492	-76.928	4.981	1.528	-76.576	5.037	-0.036	-0.352	-0.056	0.358
1.581	-83.664	4.954	1.505	-83.274	5.040	0.076	-0.390	-0.086	0.407
3.598	-83.667	11.989	3.318	-83.276	12.086	0.280	-0.391	-0.097	0.491
5.518	-83.671	19.053	5.152	-83.280	19.128	0.366	-0.391	-0.075	0.541
7.518	-84.902	10.695	7.402	-85.317	10.747	0.116	0.415	-0.052	0.434
6.386	-83.672	21.598	7.509	-83.282	21.493	-1.123	-0.390	0.105	1.194
12.606	-83.667	11.812	12.890	-83.284	12.106	-0.284	-0.383	-0.294	0.560
18.084	-83.661	2.412	18.325	-83.284	2.752	-0.241	-0.377	-0.340	0.562
18.112	-76.084	2.435	18.278	-75.751	2.722	-0.166	-0.333	-0.287	0.470
12.386	-76.091	11.692	12.731	-75.751	12.014	-0.345	-0.340	-0.322	0.581
7.143	-76.097	21.234	7.358	-75.751	21.409	-0.215	-0.346	-0.175	0.443
6.086	-69.784	21.828	6.645	-69.471	21.477	-0.559	-0.313	0.351	0.730
8.950	-69.780	11.978	9.147	-69.471	12.103	-0.197	-0.309	-0.125	0.387
11.562	-69.774	2.580	11.738	-69.469	2.755	-0.176	-0.305	-0.175	0.393
11.374	-64.722	2.531	11.588	-64.447	2.715	-0.214	-0.275	-0.184	0.394
8.838	-64.729	11.953	9.042	-64.449	12.077	-0.204	-0.280	-0.124	0.368
5.449	-64.734	21.656	6.429	-64.450	21.423	-0.980	-0.284	0.233	1.047
6.494	-60.192	11.456	6.408	-59.893	11.500	0.086	-0.299	-0.044	0.315
-30.432	-50.606	-5.446	-30.314	-50.272	-5.382	-0.118	-0.334	-0.064	0.359
-30.122	-55.316	-7.740	-30.015	-54.893	-7.901	-0.107	-0.423	0.161	0.465
-29.894	-58.470	-11.618	-29.777	-58.364	-11.347	-0.117	-0.106	-0.271	0.313
-29.675	-61.676	-15.975	-29.575	-61.324	-15.831	-0.100	-0.352	-0.144	0.393
-33.824	-63.641	-16.058	-33.781	-63.270	-15.964	-0.043	-0.371	-0.094	0.386
-36.176	-61.549	-11.627	-36.061	-61.235	-11.461	-0.115	-0.314	-0.166	0.373
-38.598	-59.389	-7.863	-38.537	-59.006	-7.974	-0.061	-0.383	0.111	0.404
-42.020	-56.333	-5.391	-41.939	-55.966	-5.349	-0.081	-0.367	-0.042	0.379
-46.213	-68.466	-5.223	-46.230	-68.128	-5.253	0.017	-0.338	0.030	0.339
-41.648	-68.251	-7.731	-41.595	-67.915	-7.814	-0.053	-0.336	0.083	0.350
-38.191	-68.114	-11.482	-38.310	-67.789	-11.441	0.119	-0.325	-0.041	0.348
-35.103	-67.970	-15.673	-35.353	-67.656	-15.946	0.250	-0.314	0.273	0.485
-33.091	-71.810	-15.305	-33.230	-71.722	-15.567	0.139	-0.088	0.262	0.309
-34.947	-73.787	-11.177	-35.184	-73.800	-11.280	0.237	0.013	0.103	0.259
-37.576	-76.565	-7.381	-37.572	-76.323	-7.612	-0.004	-0.242	0.231	0.335
-40.603	-79.820	-4.771	-40.582	-79.554	-4.766	-0.021	-0.266	-0.005	0.267
-29.640	-67.639	-17.145	-29.577	-67.243	-17.455	-0.063	-0.396	0.310	0.507
-26.495	-62.584	-15.656	-26.362	-62.196	-15.585	-0.133	-0.388	-0.071	0.416
-24.986	-59.797	-11.487	-25.012	-59.708	-11.192	0.026	-0.089	-0.295	0.309

-23.421	-56.859	-7.639	-23.267	-56.455	-7.782	-0.154	-0.404	0.143	0.456
-21.197	-52.773	-5.243	-21.098	-52.476	-5.164	-0.099	-0.297	-0.079	0.323
-13.074	-62.910	-5.116	-13.042	-62.620	-4.974	-0.032	-0.290	-0.142	0.324
-17.571	-64.228	-7.547	-17.421	-63.901	-7.605	-0.150	-0.327	0.058	0.364
-21.012	-65.271	-11.304	-21.055	-64.996	-11.074	0.043	-0.275	-0.230	0.361
-23.872	-66.118	-15.350	-23.590	-65.743	-15.449	-0.282	-0.375	0.099	0.480
-24.511	-70.321	-15.044	-24.165	-70.141	-15.263	-0.346	-0.180	0.219	0.447
-22.113	-71.636	-11.092	-21.769	-71.457	-11.092	-0.344	-0.179	0.000	0.388
-18.703	-73.487	-7.326	-18.538	-73.210	-7.450	-0.165	-0.277	0.124	0.345
-14.691	-75.691	-4.780	-14.447	-75.457	-4.901	-0.244	-0.234	0.121	0.359
-24.697	-83.522	-4.590	-24.555	-83.383	-4.728	-0.142	-0.139	0.138	0.241
-25.943	-79.244	-7.249	-25.810	-79.056	-7.509	-0.133	-0.188	0.260	0.347
-27.078	-75.303	-10.971	-26.837	-75.515	-11.114	-0.241	0.212	0.143	0.352
-27.794	-72.812	-14.858	-27.594	-72.871	-15.235	-0.200	0.059	0.377	0.430
-31.910	-72.505	-15.109	-32.258	-72.379	-15.457	0.348	-0.126	0.348	0.509
-33.171	-74.782	-11.052	-33.318	-74.875	-11.163	0.147	0.093	0.111	0.207
-35.127	-78.284	-7.317	-35.098	-78.067	-7.555	-0.029	-0.217	0.238	0.323
-37.235	-82.131	-4.627	-37.286	-82.052	-4.858	0.051	-0.079	0.231	0.249
-25.382	-86.373	-0.250	-25.299	-86.029	-0.284	-0.083	-0.344	0.034	0.355
-13.020	-77.496	-0.543	-13.007	-77.136	-0.457	-0.013	-0.360	-0.086	0.370
-10.869	-62.090	-0.647	-10.790	-61.786	-0.618	-0.079	-0.304	-0.029	0.316
-15.848	-53.716	-0.681	-15.801	-53.464	-0.589	-0.047	-0.252	-0.092	0.273
-25.634	-48.273	-0.742	-25.542	-48.084	-0.599	-0.092	-0.189	-0.143	0.255
-47.407	-38.121	18.973	-47.127	-37.910	19.015	-0.280	-0.211	-0.042	0.353
-44.205	-36.644	12.590	-43.961	-36.460	12.650	-0.244	-0.184	-0.060	0.312
-40.740	-35.024	6.385	-40.580	-34.882	6.436	-0.160	-0.142	-0.051	0.220
-40.191	-41.548	6.194	-40.009	-41.345	6.272	-0.182	-0.203	-0.078	0.283
-43.738	-40.877	12.528	-43.440	-40.693	12.626	-0.298	-0.184	-0.098	0.364
-47.118	-40.220	18.956	-46.795	-40.031	19.022	-0.323	-0.189	-0.066	0.380
-48.305	-41.896	18.784	-47.876	-41.879	18.958	-0.429	-0.017	-0.174	0.463
-45.812	-44.538	12.464	-45.446	-44.469	12.635	-0.366	-0.069	-0.171	0.410
-43.330	-47.151	6.130	-42.993	-47.054	6.323	-0.337	-0.097	-0.193	0.400
-49.131	-49.767	6.030	-48.861	-49.776	6.268	-0.270	0.009	-0.238	0.360
-49.627	-46.091	12.304	-49.330	-46.270	12.597	-0.297	0.179	-0.293	0.454
-50.108	-42.512	18.637	-49.818	-42.589	18.825	-0.290	0.077	-0.188	0.354
-52.560	-41.865	18.661	-51.909	-42.112	18.798	-0.651	0.247	-0.137	0.709
-53.976	-45.331	12.386	-53.564	-45.535	12.622	-0.412	0.204	-0.236	0.517
-55.730	-48.551	6.090	-55.265	-48.697	6.323	-0.465	0.146	-0.233	0.541
-50.926	-40.614	22.788	-50.949	-40.256	22.814	0.023	-0.358	-0.026	0.360
-56.598	-42.519	12.437	-56.773	-42.516	12.777	0.175	-0.003	-0.340	0.383
-61.990	-45.107	2.425	-62.059	-45.045	2.771	0.069	-0.062	-0.346	0.359
-63.362	-37.193	2.639	-63.151	-36.976	2.814	-0.211	-0.217	-0.175	0.350
-57.313	-38.324	12.556	-57.216	-38.090	12.722	-0.097	-0.234	-0.166	0.303
-51.461	-39.308	22.590	-51.531	-39.064	22.777	0.070	-0.244	-0.187	0.315
-51.334	-38.615	22.783	-51.130	-38.345	22.829	-0.204	-0.270	-0.046	0.342
-55.608	-34.169	12.878	-55.434	-33.878	13.022	-0.174	-0.291	-0.144	0.368
-59.692	-29.817	2.854	-59.450	-29.592	3.019	-0.242	-0.225	-0.165	0.369
-52.157	-26.247	2.891	-51.869	-26.248	2.921	-0.288	0.001	-0.030	0.290
-51.416	-32.266	12.856	-51.147	-32.115	12.900	-0.269	-0.151	-0.044	0.312

-50.080	-38.083	23.187	-50.421	-37.850	22.955	0.341	-0.233	0.232	0.473
-50.047	-38.325	22.828	-49.696	-38.072	22.881	-0.351	-0.253	-0.053	0.436
-47.078	-33.032	12.865	-46.849	-32.906	12.893	-0.229	-0.126	-0.028	0.263
-44.059	-27.967	2.799	-43.854	-27.875	2.877	-0.205	-0.092	-0.078	0.237
-46.345	3.592	25.222	-45.950	3.429	25.352	-0.395	0.163	-0.130	0.447
-50.316	7.397	27.348	-50.056	7.371	27.435	-0.260	0.026	-0.087	0.276
-53.788	10.703	22.052	-53.539	10.700	22.081	-0.249	0.003	-0.029	0.251
-56.556	13.370	8.456	-56.359	13.413	8.554	-0.197	-0.043	-0.098	0.224
-61.496	-1.915	8.344	-61.466	-1.944	8.470	-0.030	0.029	-0.126	0.132
-57.589	-1.599	21.797	-57.552	-1.628	21.913	-0.037	0.029	-0.116	0.125
-53.256	-1.258	27.197	-53.005	-1.272	27.307	-0.251	0.014	-0.110	0.274
-47.880	-0.876	25.194	-47.420	-0.885	25.333	-0.460	0.009	-0.139	0.480
-45.387	-4.714	25.525	-45.141	-4.736	25.455	-0.246	0.022	0.070	0.256
-48.810	-9.132	26.933	-48.610	-9.202	27.251	-0.200	0.070	-0.318	0.383
-51.397	-12.543	21.724	-51.440	-12.917	21.945	0.043	0.374	-0.221	0.436
-53.723	-15.643	8.318	-53.753	-16.000	8.482	0.030	0.357	-0.164	0.395
-38.522	-19.003	8.326	-38.255	-19.263	8.455	-0.267	0.260	-0.129	0.394
-39.251	-15.396	21.756	-38.976	-15.653	21.881	-0.275	0.257	-0.125	0.397
-40.048	-11.290	27.237	-39.815	-11.301	27.325	-0.233	0.011	-0.088	0.249
-41.122	-5.620	25.632	-40.870	-5.697	25.516	-0.252	0.077	0.116	0.288
-40.235	19.860	8.584	-39.976	19.827	8.657	-0.259	0.033	-0.073	0.271
-40.634	15.947	22.222	-40.370	15.969	22.258	-0.264	-0.022	-0.036	0.267
-41.102	10.946	27.470	-40.847	10.861	27.405	-0.255	0.085	0.065	0.276
-41.576	5.499	25.169	-41.332	5.347	25.217	-0.244	0.152	-0.048	0.292
-38.588	4.201	25.291	-38.370	4.119	25.282	-0.218	0.082	0.009	0.233
-35.238	8.666	27.503	-35.021	8.578	27.420	-0.217	0.088	0.083	0.248
-32.376	12.402	22.108	-32.076	12.426	22.154	-0.300	-0.024	-0.046	0.304
-30.033	15.419	8.534	-29.831	15.302	8.591	-0.202	0.117	-0.057	0.240
-23.865	6.454	8.477	-23.669	6.388	8.541	-0.196	0.066	-0.064	0.216
-27.425	5.138	21.960	-27.087	5.132	22.018	-0.338	0.006	-0.058	0.343
-31.563	3.588	27.365	-31.366	3.531	27.305	-0.197	0.057	0.060	0.213
-36.847	1.550	25.448	-36.639	1.503	25.420	-0.208	0.047	0.028	0.215
-36.747	-1.525	25.542	-36.597	-1.538	25.564	-0.150	0.013	-0.022	0.152
-31.150	-2.626	27.270	-30.937	-2.657	27.314	-0.213	0.031	-0.044	0.220
-27.114	-3.446	21.798	-26.682	-3.526	21.899	-0.432	0.080	-0.101	0.451
-23.426	-4.199	8.400	-22.994	-4.287	8.512	-0.432	0.088	-0.112	0.455
-28.397	-13.484	8.362	-27.970	-13.717	8.493	-0.427	0.233	-0.131	0.504
-30.931	-11.090	21.868	-30.607	-11.216	21.942	-0.324	0.126	-0.074	0.356
-34.071	-8.098	27.285	-33.868	-8.094	27.266	-0.203	-0.004	0.019	0.204
-38.304	-4.070	25.690	-38.074	-4.091	25.634	-0.230	0.021	0.056	0.238
-42.160	5.450	25.238	-41.901	5.241	25.346	-0.259	0.209	-0.108	0.350
-42.212	10.965	27.382	-41.955	10.897	27.364	-0.257	0.068	0.018	0.266
-42.239	16.146	22.274	-41.979	16.084	22.275	-0.260	0.062	-0.001	0.267
-42.223	19.911	8.570	-41.968	20.009	8.667	-0.255	-0.098	-0.097	0.290
-40.662	0.818	20.425	-40.412	0.734	20.424	-0.250	0.084	0.001	0.264
-45.029	-0.239	21.774	-44.721	-0.278	21.793	-0.308	0.039	-0.019	0.312
-41.167	-2.242	21.944	-40.874	-2.337	21.868	-0.293	0.095	0.076	0.317
44.991	-41.449	14.971	44.714	-41.329	15.001	0.277	-0.120	-0.030	0.304
42.467	-46.060	13.173	42.364	-46.052	13.267	0.103	-0.008	-0.094	0.140

40.367	-49.802	9.673	40.266	-49.908	9.852	0.101	0.106	-0.179	0.231
38.908	-52.554	5.063	38.799	-52.616	5.185	0.109	0.062	-0.122	0.175
31.982	-45.065	5.185	31.749	-44.921	5.257	0.233	-0.144	-0.072	0.283
35.039	-43.869	9.816	34.714	-43.761	9.945	0.325	-0.108	-0.129	0.366
39.121	-42.268	13.315	38.863	-42.139	13.352	0.258	-0.129	-0.037	0.291
44.085	-40.325	15.038	43.805	-40.208	15.091	0.280	-0.117	-0.053	0.308
44.037	-38.680	15.101	43.755	-38.568	15.171	0.282	-0.112	-0.070	0.311
38.962	-36.966	13.383	38.704	-36.857	13.429	0.258	-0.109	-0.046	0.284
34.563	-35.478	10.081	34.415	-35.402	10.047	0.148	-0.076	0.034	0.170
31.619	-34.476	5.240	31.471	-34.395	5.277	0.148	-0.081	-0.037	0.173
38.090	-25.883	5.403	37.931	-25.954	5.404	0.159	0.071	-0.001	0.174
39.826	-28.765	10.187	39.635	-28.782	10.132	0.191	0.017	0.055	0.199
42.243	-32.758	13.533	41.991	-32.681	13.536	0.252	-0.077	-0.003	0.264
45.064	-37.393	15.127	44.787	-37.290	15.136	0.277	-0.103	-0.009	0.295
46.679	-37.080	15.057	46.399	-36.965	15.162	0.280	-0.115	-0.105	0.320
47.496	-31.744	13.468	47.217	-31.642	13.541	0.279	-0.102	-0.073	0.306
48.212	-27.118	10.181	47.929	-27.060	10.222	0.283	-0.058	-0.041	0.292
48.707	-23.982	5.349	48.460	-23.699	5.504	0.247	-0.283	-0.155	0.406
38.908	-52.553	5.063	38.799	-52.616	5.185	0.109	0.063	-0.122	0.176
40.366	-49.806	9.676	40.267	-49.907	9.851	0.099	0.101	-0.175	0.225
42.466	-46.060	13.171	42.365	-46.051	13.268	0.101	-0.009	-0.097	0.140
44.991	-41.447	14.970	44.713	-41.327	14.995	0.278	-0.120	-0.025	0.304
47.277	-37.247	15.019	46.991	-37.142	15.073	0.286	-0.105	-0.054	0.309
49.838	-32.551	13.372	49.563	-32.433	13.480	0.275	-0.118	-0.108	0.317
52.048	-28.534	10.051	51.768	-28.405	10.162	0.280	-0.129	-0.111	0.328
53.512	-25.787	5.274	53.631	-25.524	5.495	-0.119	-0.263	-0.221	0.364
61.029	-34.683	5.454	60.202	-33.827	5.279	0.827	-0.856	0.175	1.203
58.517	-35.148	9.591	57.407	-34.911	10.047	1.110	-0.237	-0.456	1.224
53.421	-36.676	13.156	53.242	-36.529	13.450	0.179	-0.147	-0.294	0.374
48.540	-38.583	14.957	48.260	-38.471	15.086	0.280	-0.112	-0.129	0.328
48.575	-40.211	14.925	48.297	-40.107	15.075	0.278	-0.104	-0.150	0.333
53.499	-41.868	13.060	53.300	-41.797	13.325	0.199	-0.071	-0.265	0.340
57.582	-43.240	9.662	57.536	-43.222	9.982	0.046	-0.018	-0.320	0.324
60.271	-44.139	4.987	60.329	-44.161	5.229	-0.058	0.022	-0.242	0.250
54.077	-52.111	5.021	53.950	-52.297	5.253	0.127	0.186	-0.232	0.323
52.530	-49.607	9.668	52.339	-49.676	9.943	0.191	0.069	-0.275	0.342
50.288	-45.947	13.122	50.039	-45.912	13.372	0.249	-0.035	-0.250	0.355
47.560	-41.485	14.944	47.274	-41.380	15.070	0.286	-0.105	-0.126	0.329
45.960	-41.815	14.989	45.672	-41.699	15.057	0.288	-0.116	-0.068	0.317
45.178	-46.990	13.135	44.884	-46.903	13.273	0.294	-0.087	-0.138	0.336
44.552	-51.209	9.636	44.240	-51.189	9.812	0.312	-0.020	-0.176	0.359
44.112	-54.206	5.023	43.791	-54.234	5.175	0.321	0.028	-0.152	0.357
53.513	-25.786	5.274	53.629	-25.529	5.493	-0.116	-0.257	-0.219	0.357
52.048	-28.534	10.053	51.768	-28.405	10.162	0.280	-0.129	-0.109	0.327
49.838	-32.551	13.372	49.563	-32.433	13.480	0.275	-0.118	-0.108	0.317
47.277	-37.248	15.018	46.987	-37.143	15.062	0.290	-0.105	-0.044	0.312
32.430	-49.895	0.705	32.238	-49.695	0.690	0.192	-0.200	0.015	0.278
36.784	-54.195	0.368	36.536	-53.997	0.359	0.248	-0.198	0.009	0.317
45.274	-56.369	0.844	44.970	-56.218	0.967	0.304	-0.151	-0.123	0.361

54.459	-54.073	1.231	54.217	-54.085	1.630	0.242	0.012	-0.399	0.467
60.590	-47.875	1.432	60.427	-47.864	1.895	0.163	-0.011	-0.463	0.491
63.031	-39.700	1.697	62.794	-39.605	2.054	0.237	-0.095	-0.357	0.439
5.621	29.695	-9.962	5.617	29.632	-9.765	0.004	0.063	-0.197	0.207
2.251	29.665	-9.983	2.262	29.667	-9.765	-0.011	-0.002	-0.218	0.218
2.211	26.088	0.409	2.230	26.100	0.565	-0.019	-0.012	-0.156	0.157
-1.116	29.624	-10.009	-1.084	29.684	-9.774	-0.032	-0.060	-0.235	0.244
5.628	20.316	-12.424	5.618	20.352	-12.336	0.010	-0.036	-0.088	0.096
2.220	23.305	-1.867	2.233	23.207	-1.799	-0.013	0.098	-0.068	0.120
2.262	20.372	-12.453	2.268	20.299	-12.330	-0.006	0.073	-0.123	0.143
-1.105	20.458	-12.491	-1.079	20.204	-12.314	-0.026	0.254	-0.177	0.311
7.883	27.259	-10.220	8.044	27.024	-10.004	-0.161	0.235	-0.216	0.358
7.902	24.734	-10.213	7.884	24.511	-10.071	0.018	0.223	-0.142	0.265
3.739	24.726	0.327	3.908	24.511	0.477	-0.169	0.215	-0.150	0.312
7.834	22.208	-10.243	7.780	22.000	-10.113	0.054	0.208	-0.130	0.251
-4.650	27.259	-12.206	-4.585	27.035	-12.051	-0.065	0.224	-0.155	0.281
0.071	24.727	-1.887	0.199	24.515	-1.824	-0.128	0.212	-0.063	0.256
-4.519	24.734	-12.259	-4.493	24.522	-12.090	-0.026	0.212	-0.169	0.272
-4.398	22.208	-12.309	-4.410	22.011	-12.123	0.012	0.197	-0.186	0.271
-9.180	4.731	-1.778	-9.148	4.648	-1.671	-0.032	0.083	-0.107	0.139
-9.166	4.687	10.007	-9.090	4.583	10.051	-0.076	0.104	-0.044	0.136
-0.623	10.311	10.039	-0.596	10.089	10.076	-0.027	0.222	-0.037	0.227
-0.571	10.272	-1.747	-0.545	10.020	-1.644	-0.026	0.252	-0.103	0.274
8.519	5.753	-1.717	8.572	5.693	-1.613	-0.053	0.060	-0.104	0.131
8.697	5.907	10.069	8.752	5.852	10.102	-0.055	0.055	-0.033	0.085
10.086	-3.634	10.069	10.158	-3.745	10.103	-0.072	0.111	-0.034	0.137
10.136	-3.634	1.232	10.086	-3.708	1.315	0.050	0.074	-0.083	0.122
0.089	-10.792	1.192	0.081	-10.803	1.285	0.008	0.011	-0.093	0.094
0.053	-10.823	10.033	0.048	-10.924	10.076	0.005	0.101	-0.043	0.110
-10.010	-3.645	10.001	-9.908	-3.681	10.042	-0.102	0.036	-0.041	0.116
-9.986	-3.645	1.162	-9.889	-3.684	1.255	-0.097	0.039	-0.093	0.140
10.618	-10.330	4.178	10.842	-10.630	4.251	-0.224	0.300	-0.073	0.382
-11.001	-9.761	4.090	-11.137	-9.931	4.167	0.136	0.170	-0.077	0.231
-14.138	1.557	1.140	-14.336	1.530	1.231	0.198	0.027	-0.091	0.219
-8.155	11.647	4.120	-8.293	11.808	4.189	0.138	-0.161	-0.069	0.222
3.495	13.923	1.222	3.566	14.078	1.307	-0.071	-0.155	-0.085	0.191
12.733	6.564	4.201	12.775	6.501	4.267	-0.042	0.063	-0.066	0.101
2.004	1.847	-16.868	1.168	1.758	-16.678	0.836	0.089	-0.190	0.862
-3.673	3.517	-16.131	-3.649	3.423	-16.555	-0.024	0.094	0.424	0.435
-3.754	-4.417	-16.088	-3.734	-4.466	-16.578	-0.020	0.049	0.490	0.493
3.820	-4.269	-16.156	3.795	-4.326	-16.600	0.025	0.057	0.444	0.448
0.582	-0.708	-18.921	-0.212	-0.184	-20.471	0.794	-0.524	1.550	1.819
-9.359	-8.857	12.590	-9.306	-8.869	12.299	-0.053	0.012	0.291	0.296
-12.000	3.200	12.580	-11.921	3.122	12.321	-0.079	0.078	0.259	0.282
-0.928	11.684	12.367	-0.902	11.547	12.065	-0.026	0.137	0.302	0.332
11.235	4.616	12.314	11.185	4.509	12.039	0.050	0.107	0.275	0.300
10.584	-7.325	12.372	10.528	-7.366	12.067	0.056	0.041	0.305	0.312
0.446	-13.134	12.423	0.441	-13.132	12.152	0.005	-0.002	0.271	0.271
-0.405	-14.794	7.217	-0.420	-15.050	7.275	0.015	0.256	-0.058	0.263

7.723	-47.086	7.094	7.771	-46.901	7.160	-0.048	-0.185	-0.066	0.202
7.918	-37.078	7.102	7.917	-36.949	7.166	0.001	-0.129	-0.064	0.144
7.682	-27.072	7.107	7.533	-26.999	7.169	0.149	-0.073	-0.062	0.177
7.316	-17.066	7.112	7.223	-17.050	7.171	0.093	-0.016	-0.059	0.112
5.260	-18.026	7.095	4.905	-18.002	7.150	0.355	-0.024	-0.055	0.360
5.495	-27.748	7.090	5.036	-27.672	7.147	0.459	-0.076	-0.057	0.469
5.687	-37.471	7.085	5.270	-37.340	7.144	0.417	-0.131	-0.059	0.441
5.558	-47.192	7.078	5.293	-47.010	7.141	0.265	-0.182	-0.063	0.327
-3.757	-47.213	9.998	-3.348	-47.016	10.053	-0.409	-0.197	-0.055	0.457
-3.733	-37.526	10.003	-3.552	-37.385	10.055	-0.181	-0.141	-0.052	0.235
-3.918	-27.843	10.008	-3.781	-27.754	10.058	-0.137	-0.089	-0.050	0.171
-3.922	-18.157	10.014	-3.762	-18.124	10.063	-0.160	-0.033	-0.049	0.171
-7.703	-16.414	4.100	-7.767	-16.388	4.176	0.064	-0.026	-0.076	0.102
-7.656	-26.614	4.094	-7.622	-26.532	4.173	-0.034	-0.082	-0.079	0.118
-7.601	-36.815	4.089	-7.630	-36.677	4.170	0.029	-0.138	-0.081	0.163
-7.442	-47.013	4.083	-7.570	-46.820	4.166	0.128	-0.193	-0.083	0.246
-6.021	-49.970	7.485	-6.028	-50.709	7.553	0.007	0.739	-0.068	0.742
4.721	-50.389	10.765	5.644	-50.183	10.809	-0.923	-0.206	-0.044	0.947
6.659	-46.859	12.721	5.636	-46.675	12.226	1.023	-0.184	0.495	1.151
5.723	-37.815	12.476	5.664	-37.682	12.209	0.059	-0.133	0.267	0.304
5.630	-28.772	12.457	4.710	-28.688	12.710	0.920	-0.084	-0.253	0.958
5.856	-17.806	12.598	6.687	-17.781	12.688	-0.831	-0.025	-0.090	0.836
-6.134	-17.248	12.569	-6.106	-17.218	12.269	-0.028	-0.030	0.300	0.303
-6.253	-27.652	12.603	-6.234	-27.564	12.310	-0.019	-0.088	0.293	0.307
-6.275	-36.469	12.609	-6.265	-36.332	12.299	-0.010	-0.137	0.310	0.339
-5.813	-48.222	12.308	-5.817	-48.020	12.322	0.004	-0.202	-0.014	0.202
63.078	-86.082	-0.687	62.645	-85.738	0.624	0.433	-0.344	-1.311	1.422
51.644	-86.456	0.443	51.279	-86.097	0.498	0.365	-0.359	-0.055	0.515
30.900	-85.978	0.246	30.648	-85.606	0.331	0.252	-0.372	-0.085	0.457
26.914	-78.260	0.116	26.694	-77.925	0.206	0.220	-0.335	-0.090	0.411
40.099	-79.984	0.261	39.804	-79.652	0.253	0.295	-0.332	0.008	0.444
56.533	-76.593	0.544	56.151	-76.294	0.528	0.382	-0.299	0.016	0.486
61.181	-67.293	0.420	60.782	-67.051	0.454	0.399	-0.242	-0.034	0.468
47.192	-70.547	0.128	46.867	-70.273	0.121	0.325	-0.274	0.007	0.425
37.673	-66.152	-0.090	37.406	-65.893	-0.140	0.267	-0.259	0.050	0.376
24.024	-65.824	-0.221	23.831	-65.556	-0.134	0.193	-0.268	-0.087	0.342
20.062	-53.725	-0.417	19.903	-53.518	-0.477	0.159	-0.207	0.060	0.268
15.293	-46.598	-0.585	15.169	-46.426	-0.700	0.124	-0.172	0.115	0.241
23.702	-45.851	-0.489	23.532	-45.692	-0.647	0.170	-0.159	0.158	0.281
14.941	-35.663	-0.692	14.830	-35.553	-1.011	0.111	-0.110	0.319	0.356
15.803	-25.703	-0.830	15.698	-25.649	-1.148	0.105	-0.054	0.318	0.339
25.715	-28.639	-0.505	25.551	-28.578	-0.750	0.164	-0.061	0.245	0.301
33.700	-23.644	-0.325	33.494	-23.620	-0.572	0.206	-0.024	0.247	0.322
61.788	-24.788	0.362	61.425	-24.780	0.380	0.363	-0.008	-0.018	0.364
68.169	-35.307	0.550	67.760	-35.249	0.583	0.409	-0.058	-0.033	0.415
65.367	-55.278	0.503	64.954	-55.107	0.554	0.413	-0.171	-0.051	0.450
69.019	-6.857	0.533	68.634	-6.958	0.612	0.385	0.101	-0.079	0.406
66.189	18.142	0.271	65.841	17.904	0.560	0.348	0.238	-0.289	0.511
52.283	18.718	-0.080	52.015	18.489	-0.096	0.268	0.229	0.016	0.353

38.409	18.467	-0.775	38.216	18.253	-0.522	0.193	0.214	-0.253	0.384
25.055	18.788	-0.574	24.939	18.584	-0.734	0.116	0.204	0.160	0.284
27.155	28.247	-0.213	27.036	27.990	-0.284	0.119	0.257	0.071	0.292
34.296	26.586	-0.224	34.136	26.331	-0.226	0.160	0.255	0.002	0.302
46.037	25.650	-0.074	45.810	25.390	-0.056	0.227	0.260	-0.018	0.345
45.719	34.192	0.297	45.502	33.884	0.216	0.217	0.308	0.081	0.385
29.746	39.103	0.027	29.622	38.784	0.013	0.124	0.319	0.014	0.343
17.389	41.945	-0.058	17.337	41.621	-0.132	0.052	0.324	0.074	0.337
7.149	39.073	-0.098	7.152	38.774	-0.276	-0.003	0.299	0.178	0.348
10.317	49.126	0.037	10.311	48.768	0.085	0.006	0.358	-0.048	0.361
23.004	52.089	0.212	22.930	51.703	0.245	0.074	0.386	-0.033	0.394
43.303	55.343	0.470	43.120	54.919	0.427	0.183	0.424	0.043	0.464
66.494	54.013	0.729	66.180	53.575	0.624	0.314	0.438	0.105	0.549
67.089	38.037	0.013	66.753	37.686	0.687	0.336	0.351	-0.674	0.831
-12.136	40.544	-0.186	-12.025	40.256	-0.265	-0.111	0.288	0.079	0.319
-22.708	17.247	0.001	-22.561	17.098	-0.159	-0.147	0.149	0.160	0.264
-24.013	30.437	-0.020	-23.845	30.218	-0.097	-0.168	0.219	0.077	0.287
-31.191	25.751	0.140	-30.986	25.564	-0.128	-0.205	0.187	0.268	0.386
-42.921	26.411	0.013	-42.651	26.232	-0.209	-0.270	0.179	0.222	0.392
-50.414	30.265	0.015	-50.100	30.069	-0.110	-0.314	0.196	0.125	0.391
-40.372	45.816	0.065	-40.098	45.525	0.133	-0.274	0.291	-0.068	0.405
-47.495	54.372	-0.014	-47.175	54.040	0.124	-0.320	0.332	-0.138	0.481
-75.506	53.583	-0.064	-75.031	53.284	0.098	-0.475	0.299	-0.162	0.585
-75.720	37.302	0.014	-75.259	37.092	0.210	-0.461	0.210	-0.196	0.543
-74.503	19.145	-0.055	-74.065	19.032	0.115	-0.438	0.113	-0.170	0.483
-57.026	25.049	-0.101	-56.679	24.890	-0.160	-0.347	0.159	0.059	0.387
-66.063	11.741	-0.124	-65.679	11.664	-0.128	-0.384	0.077	0.004	0.392
-68.573	-1.320	-0.102	-68.190	-1.321	-0.053	-0.383	0.001	-0.049	0.386
-76.927	-11.014	-0.019	-76.505	-10.954	0.089	-0.422	-0.060	-0.108	0.440
-76.787	-29.491	-0.041	-76.381	-29.327	0.118	-0.406	-0.164	-0.159	0.466
-62.521	-25.085	-0.022	-62.191	-24.959	-0.187	-0.330	-0.126	0.165	0.390
-49.835	-22.121	-0.118	-49.573	-22.025	-0.363	-0.262	-0.096	0.245	0.371
-35.505	-26.820	0.016	-35.326	-26.710	-0.349	-0.179	-0.110	0.365	0.421
-22.753	-18.335	0.041	-22.636	-18.286	-0.366	-0.117	-0.049	0.407	0.426
-27.760	-37.280	-0.215	-27.635	-37.120	-0.369	-0.125	-0.160	0.154	0.255
-13.628	-51.361	-0.205	-13.597	-51.136	-0.340	-0.031	-0.225	0.135	0.265
-5.127	-60.414	-0.447	-5.151	-60.146	-0.508	0.024	-0.268	0.061	0.276
-6.362	-71.217	-0.287	-6.390	-70.888	-0.270	0.028	-0.329	-0.017	0.331
-7.705	-86.435	-0.031	-7.740	-86.021	0.079	0.035	-0.414	-0.110	0.429
-27.133	-91.035	0.077	-27.065	-90.576	0.165	-0.068	-0.459	-0.088	0.472
-40.826	-88.794	0.099	-40.678	-88.334	0.179	-0.148	-0.460	-0.080	0.489
-53.584	-82.384	0.210	-53.359	-81.947	0.247	-0.225	-0.437	-0.037	0.493
-62.792	-91.008	0.300	-62.524	-90.516	0.244	-0.268	-0.492	0.056	0.563
-77.119	-86.310	0.259	-76.767	-85.830	0.280	-0.352	-0.480	-0.021	0.595
-75.467	-64.738	0.145	-75.103	-64.377	0.210	-0.364	-0.361	-0.065	0.516
-71.861	-44.469	0.087	-71.498	-44.226	0.114	-0.363	-0.243	-0.027	0.438
-65.705	-56.371	0.047	-65.388	-56.068	0.017	-0.317	-0.303	0.030	0.440
-62.077	-66.162	0.122	-61.787	-65.808	0.115	-0.290	-0.354	0.007	0.457
-50.361	-59.096	-0.136	-50.130	-58.793	-0.211	-0.231	-0.303	0.075	0.388

-50.114	-73.152	0.022	-49.899	-72.772	0.028	-0.215	-0.380	-0.006	0.436
-13.930	-38.208	-16.696	-13.886	-38.060	-17.221	-0.044	-0.148	0.525	0.547
-14.328	-16.813	-16.658	-14.262	-16.782	-17.238	-0.066	-0.031	0.580	0.585
-13.516	15.866	-16.542	-13.424	15.713	-17.046	-0.092	0.153	0.504	0.534
-13.349	29.071	-16.525	-13.247	28.845	-16.897	-0.102	0.226	0.372	0.447
14.711	31.339	-16.727	14.661	31.073	-17.167	0.050	0.266	0.440	0.516
15.581	23.632	-17.122	15.519	23.409	-17.684	0.062	0.223	0.562	0.608
15.846	11.942	-16.827	15.771	11.783	-17.391	0.075	0.159	0.564	0.590
60.033	4.034	-16.170	59.703	3.874	-16.388	0.330	0.160	0.218	0.427
58.475	-10.238	-16.242	58.139	-10.315	-16.544	0.336	0.077	0.302	0.458
48.984	-15.533	-16.622	48.698	-15.570	-16.947	0.286	0.037	0.325	0.434
36.575	-9.940	-16.643	36.363	-9.996	-17.214	0.212	0.056	0.571	0.611
30.808	-17.963	-16.991	30.620	-17.970	-17.461	0.188	0.007	0.470	0.507
13.348	-15.448	-16.951	13.262	-15.451	-17.533	0.086	0.003	0.582	0.588
19.591	2.531	-5.048	19.489	2.422	-5.145	0.102	0.109	0.097	0.178
28.977	6.939	-5.162	28.826	6.798	-5.067	0.151	0.141	-0.095	0.228
34.501	2.681	-4.828	34.316	2.559	-4.718	0.185	0.122	-0.110	0.248
41.255	7.064	-4.892	41.035	6.910	-4.753	0.220	0.154	-0.139	0.302
46.481	1.878	-4.295	46.227	1.749	-4.424	0.254	0.129	0.129	0.313
52.077	8.098	-4.485	51.799	7.929	-4.328	0.278	0.169	-0.157	0.362
50.896	-2.507	0.057	50.612	-3.603	0.013	0.284	1.096	0.044	1.133
40.369	-3.298	0.095	40.146	-3.393	-0.144	0.223	0.095	0.239	0.340
28.678	-3.108	-0.146	28.520	-4.005	0.002	0.158	0.897	-0.148	0.922
16.990	-1.722	-0.284	16.899	-1.626	-0.246	0.091	-0.096	-0.038	0.138
18.605	-9.631	0.989	18.498	-9.669	1.138	0.107	0.038	-0.149	0.187
24.762	-6.796	1.461	24.506	-7.782	1.817	0.256	0.986	-0.356	1.079
25.876	-15.105	1.511	25.723	-15.119	1.377	0.153	0.014	0.134	0.204
17.863	-12.373	-3.688	18.746	-12.351	-3.577	-0.883	-0.022	-0.111	0.890
25.742	-16.617	1.716	25.588	-16.393	0.805	0.154	-0.224	0.911	0.950
33.066	-3.294	-3.696	32.880	-3.682	-3.589	0.186	0.388	-0.107	0.444
40.085	-3.361	-2.914	39.863	-3.598	-2.814	0.222	0.237	-0.100	0.340
52.712	-2.938	-4.141	52.418	-3.827	-4.039	0.294	0.889	-0.102	0.941
53.353	0.430	-8.407	54.999	-0.321	-8.274	-1.646	0.751	-0.133	1.814
55.029	7.617	-9.142	56.127	7.445	-9.009	-1.098	0.172	-0.133	1.119
59.526	12.255	-0.417	59.212	12.078	-0.394	0.314	0.177	-0.023	0.361
49.312	13.355	-1.626	49.057	13.143	-1.516	0.255	0.212	-0.110	0.349
39.477	13.133	-0.441	39.273	12.694	-1.494	0.204	0.439	1.053	1.159

### 3D-Tol Data from CMM for SLS Aluminium Casting

MEAS X	MEAS Y	MEAS Z	Pattern X	Pattern Y	Pattern Z	DIF X	DIF Y	DIF Z	TOT DIF
53.671	58.560	-5.415	53.383	58.788	-5.642	0.288	-0.228	0.227	0.432
37.126	58.572	-5.441	36.930	58.757	-5.644	0.196	-0.185	0.203	0.338
20.582	58.503	-5.466	20.477	58.759	-5.648	0.105	-0.256	0.182	0.331
4.037	58.527	-5.493	4.025	58.734	-5.653	0.012	-0.207	0.160	0.262

-12.508	58.563	-5.519	-12.426	58.723	-5.658	-0.082	-0.160	0.139	0.227
-29.054	58.606	-5.545	-28.879	58.709	-5.663	-0.175	-0.103	0.118	0.235
-45.597	58.622	-5.571	-45.334	58.713	-5.666	-0.263	-0.091	0.095	0.294
-62.142	58.615	-5.597	-61.787	58.754	-5.671	-0.355	-0.139	0.074	0.388
-79.644	40.901	-5.634	-79.545	40.800	-5.686	-0.099	0.101	0.052	0.151
-79.458	24.356	-5.638	-79.567	24.346	-5.692	0.109	0.010	0.054	0.123
-79.563	7.812	-5.644	-79.585	7.894	-5.699	0.022	-0.082	0.055	0.101
-79.542	-8.733	-5.650	-79.547	-8.559	-5.706	0.005	-0.174	0.056	0.183
-79.526	-25.276	-5.655	-79.527	-25.011	-5.712	0.001	-0.265	0.057	0.271
-79.565	-41.821	-5.660	-79.550	-41.464	-5.719	-0.015	-0.357	0.059	0.362
-79.464	-58.366	-5.666	-79.568	-57.917	-5.726	0.104	-0.449	0.060	0.465
-79.717	-74.911	-5.672	-79.581	-74.370	-5.732	-0.136	-0.541	0.060	0.561
-61.979	-92.048	-5.651	-61.774	-92.196	-5.735	-0.205	0.148	0.084	0.266
-45.434	-92.066	-5.624	-45.321	-92.201	-5.732	-0.113	0.135	0.108	0.206
-28.890	-92.023	-5.598	-28.869	-92.180	-5.727	-0.021	0.157	0.129	0.204
-12.345	-91.971	-5.571	-12.416	-92.220	-5.722	0.071	0.249	0.151	0.299
4.200	-92.034	-5.545	4.035	-92.185	-5.718	0.165	0.151	0.173	0.282
20.745	-92.102	-5.519	20.489	-92.234	-5.713	0.256	0.132	0.194	0.347
37.289	-91.991	-5.493	36.941	-92.167	-5.708	0.348	0.176	0.215	0.445
53.834	-91.993	-5.467	53.393	-92.183	-5.704	0.441	0.190	0.237	0.535
71.007	-74.750	-5.433	71.384	-74.360	-5.696	-0.377	-0.390	0.263	0.603
71.103	-58.207	-5.426	71.403	-57.907	-5.683	-0.300	-0.300	0.257	0.496
71.126	-41.662	-5.421	71.359	-41.455	-5.677	-0.233	-0.207	0.256	0.404
71.003	-25.116	-5.415	71.332	-25.002	-5.670	-0.329	-0.114	0.255	0.431
71.126	-8.570	-5.410	71.323	-8.550	-5.664	-0.197	-0.020	0.254	0.322
71.074	7.972	-5.405	71.328	7.903	-5.656	-0.254	0.069	0.251	0.364
71.020	24.519	-5.399	71.291	24.355	-5.650	-0.271	0.164	0.251	0.404
71.076	41.063	-5.394	71.308	40.806	-5.643	-0.232	0.257	0.249	0.426
-69.892	43.601	8.546	-69.487	43.473	8.412	-0.405	0.128	0.134	0.446
-64.841	43.606	8.517	-64.462	43.473	8.391	-0.379	0.133	0.126	0.421
-64.845	48.656	8.462	-64.465	48.496	8.369	-0.380	0.160	0.093	0.422
-69.898	48.650	8.468	-69.487	48.493	8.413	-0.411	0.157	0.055	0.443
-67.763	46.247	8.515	-67.366	46.102	8.458	-0.397	0.145	0.057	0.427
-71.303	43.600	7.005	-71.273	43.474	6.873	-0.030	0.126	0.132	0.186
-71.328	48.649	7.008	-71.316	48.495	6.876	-0.012	0.154	0.132	0.203
-69.896	50.346	7.011	-69.487	50.392	6.875	-0.409	-0.046	0.136	0.433
-64.845	50.342	7.020	-64.463	50.372	6.877	-0.382	-0.030	0.143	0.409
-64.837	42.113	7.015	-64.463	42.022	6.872	-0.374	0.091	0.143	0.411
-69.887	42.094	7.009	-69.485	41.992	6.872	-0.402	0.102	0.137	0.437
-62.997	48.660	7.019	-62.856	48.497	6.874	-0.141	0.163	0.145	0.260
-63.006	43.610	7.018	-62.864	43.475	6.871	-0.142	0.135	0.147	0.246
-64.773	-14.467	4.217	-64.461	-14.278	4.105	-0.312	-0.189	0.112	0.382
-69.824	-14.473	4.169	-69.483	-14.278	4.112	-0.341	-0.195	0.057	0.397
-69.817	-19.523	4.207	-69.481	-19.300	4.141	-0.336	-0.223	0.066	0.409
-64.766	-19.518	4.215	-64.459	-19.299	4.137	-0.307	-0.219	0.078	0.385
-67.942	-16.899	4.179	-67.614	-16.691	4.103	-0.328	-0.208	0.076	0.396
-69.823	-12.633	3.624	-69.485	-12.555	3.501	-0.338	-0.078	0.123	0.368
-64.773	-12.617	3.631	-64.460	-12.547	3.504	-0.313	-0.070	0.127	0.345

-62.950	-14.464	3.632	-62.821	-14.274	3.499	-0.129	-0.190	0.133	0.265
-63.022	-19.515	3.630	-62.851	-19.298	3.498	-0.171	-0.217	0.132	0.306
-64.764	-21.068	4.190	-64.461	-20.975	3.498	-0.303	-0.093	0.692	0.761
-69.814	-21.091	4.175	-69.482	-20.973	3.498	-0.332	-0.118	0.677	0.763
-71.525	-19.523	4.221	-71.281	-19.298	3.499	-0.244	-0.225	0.722	0.794
-71.532	-14.473	4.216	-71.275	-14.276	3.503	-0.257	-0.197	0.713	0.783
-64.712	-77.594	8.530	-64.460	-77.053	8.422	-0.252	-0.541	0.108	0.607
-69.763	-77.599	8.501	-69.482	-77.054	8.454	-0.281	-0.545	0.047	0.615
-69.756	-82.650	8.491	-69.480	-82.075	8.532	-0.276	-0.575	-0.041	0.639
-64.706	-82.644	8.505	-64.458	-82.074	8.472	-0.248	-0.570	0.033	0.622
-69.761	-75.604	6.969	-69.482	-75.457	6.825	-0.279	-0.147	0.144	0.347
-64.710	-75.585	6.977	-64.459	-75.464	6.827	-0.251	-0.121	0.150	0.316
-63.056	-77.591	6.977	-62.758	-77.050	6.822	-0.298	-0.541	0.155	0.637
-63.028	-82.641	6.977	-62.835	-82.073	6.821	-0.193	-0.568	0.156	0.620
-64.702	-83.805	6.973	-64.458	-83.842	6.822	-0.244	0.037	0.151	0.289
-69.753	-83.817	6.967	-69.481	-83.854	6.823	-0.272	0.037	0.144	0.310
-71.380	-82.648	6.963	-71.307	-82.072	6.823	-0.073	-0.576	0.140	0.597
-71.444	-77.600	6.967	-71.369	-77.051	6.829	-0.075	-0.549	0.138	0.572
-2.551	43.674	4.152	-2.526	43.477	4.031	-0.025	0.197	0.121	0.233
2.499	43.680	4.179	2.496	43.478	4.096	0.003	0.202	0.083	0.219
2.494	48.730	4.171	2.495	48.499	4.096	-0.001	0.231	0.075	0.242
-2.558	48.724	4.109	-2.527	48.498	4.060	-0.031	0.226	0.049	0.233
-0.714	46.708	4.117	-0.694	46.494	4.050	-0.020	0.214	0.067	0.225
-4.107	43.673	2.483	-4.137	43.478	2.287	0.030	0.195	0.196	0.278
-4.108	48.724	2.489	-4.169	48.499	2.294	0.061	0.225	0.195	0.303
2.503	42.039	2.492	2.497	41.978	2.287	0.006	0.061	0.205	0.214
-2.547	42.059	2.486	-2.526	41.978	2.286	-0.021	0.081	0.200	0.217
4.150	48.733	2.498	4.280	48.501	2.289	-0.130	0.232	0.209	0.338
4.193	43.681	2.497	4.346	43.479	2.286	-0.153	0.202	0.211	0.330
-2.555	50.215	2.488	-2.530	50.327	2.290	-0.025	-0.112	0.198	0.229
2.496	50.214	2.497	2.495	50.325	2.293	0.001	-0.111	0.204	0.232
-64.796	36.065	-0.983	-64.582	36.115	-1.084	-0.214	-0.050	0.101	0.241
-54.066	46.763	-0.962	-53.930	46.770	-1.077	-0.136	-0.007	0.115	0.178
-46.783	46.952	-0.951	-46.586	46.719	-1.072	-0.197	0.233	0.121	0.328
-36.025	36.287	-0.937	-35.949	36.046	-1.073	-0.076	0.241	0.136	0.287
-40.997	28.926	-0.946	-40.702	28.926	-1.075	-0.295	0.000	0.129	0.322
-48.166	36.046	-0.954	-47.833	35.999	-1.075	-0.333	0.047	0.121	0.357
-35.677	29.384	-1.319	-35.660	29.471	-1.453	-0.017	-0.087	0.134	0.161
-54.233	35.030	-0.161	-53.913	34.917	-1.078	-0.320	0.113	0.917	0.978
-58.990	30.265	-0.158	-58.654	30.181	-1.076	-0.336	0.084	0.918	0.981
-65.262	29.597	-0.885	-64.961	29.486	-0.985	-0.301	0.111	0.100	0.336
-61.397	33.408	-3.909	-61.066	33.328	-4.205	-0.331	0.080	0.296	0.451
-56.834	38.168	-3.821	-56.521	38.057	-4.150	-0.313	0.111	0.329	0.467
-50.344	43.577	-3.891	-50.063	43.430	-4.131	-0.281	0.147	0.240	0.398
-44.780	38.535	-3.893	-44.536	38.410	-4.215	-0.244	0.125	0.322	0.423
-40.099	33.731	-3.900	-39.885	33.629	-4.264	-0.214	0.102	0.364	0.435
49.631	41.984	6.354	49.366	42.018	6.066	0.265	-0.034	0.288	0.393
42.897	42.005	6.346	42.670	41.966	6.065	0.227	0.039	0.281	0.363
54.517	30.268	6.358	54.494	30.086	6.064	0.023	0.182	0.294	0.347

54.491	37.003	6.364	54.506	36.784	6.070	-0.015	0.219	0.294	0.367
58.789	25.295	5.869	58.456	25.241	5.571	0.333	0.054	0.298	0.451
62.678	30.278	6.373	62.898	30.089	6.064	-0.220	0.189	0.309	0.424
62.637	37.853	6.375	62.878	37.621	6.069	-0.241	0.232	0.306	0.453
62.615	45.428	6.378	62.834	45.154	6.073	-0.219	0.274	0.305	0.465
58.039	50.093	6.371	57.734	50.332	6.075	0.305	-0.239	0.296	0.488
50.463	50.151	6.361	50.200	50.361	6.074	0.263	-0.210	0.287	0.442
42.888	50.199	6.349	42.667	50.359	6.071	0.221	-0.160	0.278	0.389
37.820	46.193	5.620	37.772	45.940	5.354	0.048	0.253	0.266	0.370
43.137	46.366	8.484	42.917	46.107	8.299	0.220	0.259	0.185	0.387
50.372	46.083	8.449	50.110	45.818	8.355	0.262	0.265	0.094	0.384
58.344	45.761	8.553	58.038	45.488	8.402	0.306	0.273	0.151	0.437
59.093	37.497	8.472	58.774	37.270	8.315	0.319	0.227	0.157	0.422
58.975	30.651	8.507	58.650	30.462	8.381	0.325	0.189	0.126	0.397
-30.955	49.050	17.126	-30.750	48.832	16.892	-0.205	0.218	0.234	0.380
-30.944	46.137	12.101	-30.747	45.943	11.892	-0.197	0.194	0.209	0.347
-30.932	43.207	7.092	-30.746	43.084	6.878	-0.186	0.123	0.214	0.309
-30.922	40.259	2.097	-30.744	40.131	1.920	-0.178	0.128	0.177	0.282
-27.132	40.305	2.079	-26.979	40.164	1.905	-0.153	0.141	0.174	0.271
-27.145	43.202	7.104	-26.981	43.073	6.888	-0.164	0.129	0.216	0.300
-27.156	46.143	12.108	-26.981	45.971	11.878	-0.175	0.172	0.230	0.336
-27.167	49.074	17.120	-26.984	48.857	16.878	-0.183	0.217	0.242	0.373
-23.378	49.046	17.146	-23.218	48.851	16.883	-0.160	0.195	0.263	0.364
-23.369	46.158	12.105	-23.216	45.943	11.892	-0.153	0.215	0.213	0.339
-23.357	43.210	7.107	-23.213	43.058	6.899	-0.144	0.152	0.208	0.295
-23.346	40.277	2.102	-23.212	40.158	1.910	-0.134	0.119	0.192	0.262
-17.040	45.417	2.215	-16.936	45.349	2.002	-0.104	0.068	0.213	0.247
-17.053	47.456	9.746	-16.937	47.390	9.489	-0.116	0.066	0.257	0.290
-17.068	49.525	17.274	-16.939	49.379	16.993	-0.129	0.146	0.281	0.342
-12.017	49.590	17.265	-11.916	49.399	16.990	-0.101	0.191	0.275	0.350
-12.003	47.481	9.749	-11.916	47.374	9.497	-0.087	0.107	0.252	0.287
-11.990	45.400	2.227	-11.913	45.355	2.002	-0.077	0.045	0.225	0.242
-8.303	49.518	7.901	-8.124	49.295	7.678	-0.179	0.223	0.223	0.363
-30.955	50.638	15.363	-30.753	50.774	15.224	-0.202	-0.136	0.139	0.281
-30.947	52.144	9.705	-30.751	52.273	9.599	-0.196	-0.129	0.106	0.258
-30.940	53.616	4.041	-30.750	53.754	3.971	-0.190	-0.138	0.070	0.245
-24.206	53.585	4.044	-24.051	53.729	3.963	-0.155	-0.144	0.081	0.226
-24.214	52.078	9.697	-24.052	52.216	9.584	-0.162	-0.138	0.113	0.240
-24.221	50.642	15.375	-24.054	50.751	15.218	-0.167	-0.109	0.157	0.254
-17.487	50.648	15.384	-17.359	50.729	15.214	-0.128	-0.081	0.170	0.228
-17.481	52.119	9.717	-17.359	52.254	9.595	-0.122	-0.135	0.122	0.219
-17.474	53.573	4.050	-17.356	53.727	3.963	-0.118	-0.154	0.087	0.213
-10.739	53.562	4.055	-10.659	53.715	3.966	-0.080	-0.153	0.089	0.194
-10.746	52.131	9.729	-10.661	52.235	9.592	-0.085	-0.104	0.137	0.192
-10.753	50.644	15.391	-10.662	50.746	15.222	-0.091	-0.102	0.169	0.217
-33.162	48.833	10.006	-33.304	48.638	9.807	0.142	0.195	0.199	0.313
5.100	-63.214	19.207	5.070	-62.826	18.880	0.030	-0.388	0.327	0.508
3.246	-63.213	12.130	3.202	-62.823	11.847	0.044	-0.390	0.283	0.484

1.387	-63.213	5.052	1.328	-62.820	4.816	0.059	-0.393	0.236	0.462
1.377	-69.948	5.055	1.349	-69.517	4.808	0.028	-0.431	0.247	0.498
3.254	-69.948	12.127	3.225	-69.519	11.838	0.029	-0.429	0.289	0.518
5.065	-69.949	19.216	5.073	-69.521	18.877	-0.008	-0.428	0.339	0.546
5.108	-76.681	19.203	5.084	-76.218	18.871	0.024	-0.463	0.332	0.570
3.267	-76.680	12.123	3.225	-76.215	11.835	0.042	-0.465	0.288	0.549
1.341	-76.679	5.064	1.321	-76.212	4.815	0.020	-0.467	0.249	0.529
1.321	-83.414	5.070	1.307	-82.909	4.817	0.014	-0.505	0.253	0.565
3.213	-83.415	12.137	3.175	-82.911	11.845	0.038	-0.504	0.292	0.584
5.063	-83.415	19.216	5.026	-82.913	18.883	0.037	-0.502	0.333	0.604
7.563	-85.316	10.715	7.407	-85.506	10.449	0.156	0.190	0.266	0.362
7.146	-83.412	21.205	7.533	-82.912	21.182	-0.387	-0.500	0.023	0.633
12.618	-83.404	11.803	12.920	-82.909	11.805	-0.302	-0.495	-0.002	0.580
18.215	-83.395	2.470	18.431	-82.904	2.489	-0.216	-0.491	-0.019	0.537
18.190	-75.819	2.465	18.463	-75.370	2.507	-0.273	-0.449	-0.042	0.527
12.611	-75.828	11.808	12.892	-75.375	11.792	-0.281	-0.453	0.016	0.533
7.140	-75.837	21.211	7.517	-75.380	21.176	-0.377	-0.457	0.035	0.593
6.515	-69.525	21.429	6.860	-69.100	21.228	-0.345	-0.425	0.201	0.583
9.046	-69.521	12.007	9.332	-69.098	11.848	-0.286	-0.423	0.159	0.535
11.671	-69.515	2.611	11.973	-69.094	2.513	-0.302	-0.421	0.098	0.527
11.691	-64.465	2.621	11.930	-64.072	2.505	-0.239	-0.393	0.116	0.474
9.017	-64.470	12.004	9.323	-64.078	11.849	-0.306	-0.392	0.155	0.521
6.539	-64.477	21.440	6.798	-64.080	21.215	-0.259	-0.397	0.225	0.524
6.516	-60.571	11.471	6.391	-60.402	11.206	0.125	-0.169	0.265	0.338
-30.457	-50.296	-5.359	-30.380	-50.092	-5.334	-0.077	-0.204	-0.025	0.219
-30.145	-55.060	-7.767	-30.086	-54.697	-7.839	-0.059	-0.363	0.072	0.375
-29.913	-58.415	-11.442	-29.858	-58.304	-11.378	-0.055	-0.111	-0.064	0.139
-29.706	-61.510	-15.721	-29.673	-61.156	-15.703	-0.033	-0.354	-0.018	0.356
-33.718	-63.530	-15.641	-33.674	-63.087	-15.723	-0.044	-0.443	0.082	0.453
-36.019	-61.483	-11.398	-35.818	-61.166	-11.395	-0.201	-0.317	-0.003	0.375
-38.570	-59.206	-7.685	-38.469	-58.793	-7.797	-0.101	-0.413	0.112	0.440
-42.066	-56.084	-5.244	-41.898	-55.722	-5.302	-0.168	-0.362	0.058	0.403
-46.217	-68.253	-5.055	-46.176	-67.782	-5.281	-0.041	-0.471	0.226	0.524
-41.633	-68.034	-7.566	-41.577	-67.568	-7.780	-0.056	-0.466	0.214	0.516
-38.076	-67.874	-11.295	-38.088	-67.408	-11.427	0.012	-0.466	0.132	0.485
-35.091	-67.733	-15.474	-35.122	-67.269	-15.670	0.031	-0.464	0.196	0.504
-33.204	-71.657	-15.359	-33.312	-71.332	-15.764	0.108	-0.325	0.405	0.531
-35.136	-73.739	-11.192	-35.290	-73.463	-11.436	0.154	-0.276	0.244	0.400
-37.669	-76.450	-7.498	-37.678	-76.028	-7.836	0.009	-0.422	0.338	0.541
-40.795	-79.816	-4.977	-40.817	-79.411	-5.322	0.022	-0.405	0.345	0.532
-29.628	-67.478	-16.697	-29.345	-67.140	-16.899	-0.283	-0.338	0.202	0.485
-26.463	-62.217	-15.718	-26.490	-61.823	-15.758	0.027	-0.394	0.040	0.397
-25.172	-59.468	-11.412	-25.071	-59.258	-11.432	-0.101	-0.210	0.020	0.234
-23.401	-56.550	-7.772	-23.403	-56.172	-7.841	0.002	-0.378	0.069	0.384
-21.257	-52.296	-5.311	-21.192	-52.128	-5.338	-0.065	-0.168	0.027	0.182
-12.954	-62.627	-5.164	-13.044	-62.232	-5.330	0.090	-0.395	0.166	0.438
-17.490	-63.964	-7.676	-17.477	-63.531	-7.836	-0.013	-0.433	0.160	0.462
-20.869	-64.967	-11.318	-20.808	-64.513	-11.448	-0.061	-0.454	0.130	0.476

-23.651	-65.790	-15.608	-23.617	-65.332	-15.799	-0.034	-0.458	0.191	0.497
-24.241	-70.229	-15.421	-24.074	-69.859	-15.842	-0.167	-0.370	0.421	0.585
-21.828	-71.549	-11.180	-21.491	-71.268	-11.480	-0.337	-0.281	0.300	0.532
-18.560	-73.331	-7.550	-18.495	-72.909	-7.835	-0.065	-0.422	0.285	0.514
-14.513	-75.538	-4.940	-14.418	-75.134	-5.347	-0.095	-0.404	0.407	0.581
-24.603	-83.563	-4.849	-24.539	-83.243	-5.311	-0.064	-0.320	0.462	0.566
-25.885	-79.203	-7.491	-25.838	-78.809	-7.822	-0.047	-0.394	0.331	0.517
-26.945	-75.564	-11.136	-26.812	-75.498	-11.459	-0.133	-0.066	0.323	0.355
-27.711	-72.932	-15.311	-27.629	-72.703	-15.822	-0.082	-0.229	0.511	0.566
-32.053	-72.476	-15.344	-32.134	-72.156	-15.731	0.081	-0.320	0.387	0.509
-33.402	-74.940	-11.174	-33.569	-74.780	-11.470	0.167	-0.160	0.296	0.375
-35.196	-78.196	-7.456	-35.224	-77.807	-7.850	0.028	-0.389	0.394	0.554
-37.391	-82.215	-4.919	-37.421	-81.834	-5.296	0.030	-0.381	0.377	0.537
-25.330	-86.267	-0.253	-25.288	-85.866	-0.530	-0.042	-0.401	0.277	0.489
-12.983	-77.267	-0.487	-12.910	-76.855	-0.718	-0.073	-0.412	0.231	0.478
-10.783	-61.819	-0.723	-10.940	-61.449	-0.699	0.157	-0.370	-0.024	0.403
-15.829	-53.449	-0.732	-15.925	-53.171	-0.718	0.096	-0.278	-0.014	0.294
-25.667	-48.143	-0.645	-25.647	-47.956	-0.576	-0.020	-0.187	-0.069	0.200
-47.408	-37.963	19.080	-47.174	-37.673	18.846	-0.234	-0.290	0.234	0.440
-44.145	-36.436	12.741	-43.904	-36.126	12.568	-0.241	-0.310	0.173	0.429
-40.775	-34.841	6.477	-40.607	-34.565	6.302	-0.168	-0.276	0.175	0.367
-40.008	-41.384	6.423	-39.718	-41.103	6.328	-0.290	-0.281	0.095	0.415
-43.617	-40.708	12.720	-43.305	-40.431	12.590	-0.312	-0.277	0.130	0.437
-47.247	-40.022	19.003	-46.880	-39.754	18.857	-0.367	-0.268	0.146	0.477
-48.262	-41.753	18.953	-47.868	-41.627	18.870	-0.394	-0.126	0.083	0.422
-45.791	-44.358	12.609	-45.404	-44.240	12.576	-0.387	-0.118	0.033	0.406
-43.217	-47.074	6.354	-42.853	-46.940	6.349	-0.364	-0.134	0.005	0.388
-49.101	-49.767	6.289	-48.858	-49.764	6.337	-0.243	-0.003	-0.048	0.247
-49.586	-46.123	12.582	-49.325	-46.151	12.600	-0.261	0.028	-0.018	0.263
-50.063	-42.533	18.905	-49.782	-42.610	18.907	-0.281	0.077	-0.002	0.291
-52.110	-42.126	18.919	-51.930	-42.231	18.922	-0.180	0.105	-0.003	0.208
-53.860	-45.280	12.586	-53.661	-45.384	12.631	-0.199	0.104	-0.045	0.229
-55.617	-48.510	6.293	-55.406	-48.600	6.373	-0.211	0.090	-0.080	0.243
-51.203	-40.408	23.053	-51.518	-39.727	22.725	0.315	-0.681	0.328	0.819
-56.637	-42.366	12.630	-56.737	-42.209	12.667	0.100	-0.157	-0.037	0.190
-61.929	-44.891	2.551	-61.951	-44.678	2.606	0.022	-0.213	-0.055	0.221
-63.064	-37.072	2.626	-62.970	-36.731	2.609	-0.094	-0.341	0.017	0.354
-57.334	-38.145	12.727	-57.310	-37.796	12.675	-0.024	-0.349	0.052	0.353
-51.584	-39.178	22.820	-51.656	-38.848	22.748	0.072	-0.330	0.072	0.345
-51.338	-38.482	22.912	-51.162	-38.127	22.703	-0.176	-0.355	0.209	0.447
-55.356	-34.253	12.811	-55.155	-33.913	12.659	-0.201	-0.340	0.152	0.423
-59.378	-29.986	2.732	-59.134	-29.698	2.618	-0.244	-0.288	0.114	0.395
-52.131	-26.443	2.800	-51.892	-26.255	2.625	-0.239	-0.188	0.175	0.350
-51.382	-32.311	12.852	-51.146	-32.054	12.643	-0.236	-0.257	0.209	0.407
-50.644	-38.133	22.927	-50.399	-37.802	22.688	-0.245	-0.331	0.239	0.476
-49.952	-38.260	22.911	-49.644	-38.024	22.638	-0.308	-0.236	0.273	0.474
-47.122	-33.096	12.841	-46.864	-32.933	12.595	-0.258	-0.163	0.246	0.392
-44.289	-27.928	2.780	-44.058	-27.800	2.582	-0.231	-0.128	0.198	0.330

-46.478	3.967	25.116	-46.154	3.978	24.943	-0.324	-0.011	0.173	0.368
-50.208	7.501	27.065	-49.986	7.608	27.132	-0.222	-0.107	-0.067	0.255
-53.502	10.616	22.003	-53.422	10.856	21.894	-0.080	-0.240	0.109	0.276
-56.344	13.318	8.529	-56.226	13.516	8.415	-0.118	-0.198	0.114	0.257
-61.479	-1.730	8.492	-61.471	-1.641	8.389	-0.008	-0.089	0.103	0.136
-57.614	-1.413	21.947	-57.626	-1.332	21.855	0.012	-0.081	0.092	0.124
-53.167	-1.050	27.032	-52.995	-0.961	27.157	-0.172	-0.089	-0.125	0.230
-47.992	-0.644	25.195	-47.675	-0.534	24.993	-0.317	-0.110	0.202	0.392
-45.700	-4.892	25.148	-45.414	-4.708	24.971	-0.286	-0.184	0.177	0.384
-48.812	-8.952	27.009	-48.631	-8.911	27.109	-0.181	-0.041	-0.100	0.211
-51.460	-12.433	21.902	-51.388	-12.526	21.799	-0.072	0.093	0.103	0.156
-53.809	-15.543	8.481	-53.720	-15.577	8.363	-0.089	0.034	0.118	0.151
-38.462	-19.201	8.510	-38.257	-19.217	8.361	-0.205	0.016	0.149	0.254
-39.216	-15.330	21.922	-38.981	-15.407	21.772	-0.235	0.077	0.150	0.289
-40.040	-11.023	27.025	-39.812	-10.988	27.060	-0.228	-0.035	-0.035	0.233
-41.001	-5.965	25.188	-40.803	-5.756	25.019	-0.198	-0.209	0.169	0.334
-40.342	19.465	8.571	-40.113	19.582	8.414	-0.229	-0.117	0.157	0.301
-40.711	15.506	22.035	-40.460	15.704	21.871	-0.251	-0.198	0.164	0.359
-41.118	10.971	27.081	-40.877	11.060	27.095	-0.241	-0.089	-0.014	0.257
-41.568	5.860	25.115	-41.351	5.778	24.974	-0.217	0.082	0.141	0.271
-38.441	4.650	25.114	-38.324	4.593	24.984	-0.117	0.057	0.130	0.184
-35.349	8.732	27.086	-35.091	8.832	27.154	-0.258	-0.100	-0.068	0.284
-32.598	12.348	22.037	-32.315	12.478	21.842	-0.283	-0.130	0.195	0.368
-30.172	15.511	8.582	-29.956	15.573	8.401	-0.216	-0.062	0.181	0.288
-23.735	6.738	8.577	-23.539	6.792	8.385	-0.196	-0.054	0.192	0.279
-27.490	5.333	22.004	-27.167	5.438	21.814	-0.323	-0.105	0.190	0.389
-31.684	3.762	27.048	-31.432	3.841	27.054	-0.252	-0.079	-0.006	0.264
-36.457	1.954	25.118	-36.408	1.975	25.000	-0.049	-0.021	0.118	0.129
-36.238	-1.371	25.146	-36.171	-1.249	24.999	-0.067	-0.122	0.147	0.202
-31.233	-2.387	27.008	-30.977	-2.321	27.019	-0.256	-0.066	-0.011	0.265
-26.888	-3.279	21.972	-26.581	-3.231	21.774	-0.307	-0.048	0.198	0.368
-23.000	-4.073	8.554	-22.753	-4.019	8.374	-0.247	-0.054	0.180	0.311
-28.057	-13.619	8.538	-27.810	-13.601	8.369	-0.247	-0.018	0.169	0.300
-30.922	-10.879	21.951	-30.629	-10.893	21.772	-0.293	0.014	0.179	0.343
-34.105	-7.833	27.059	-33.854	-7.783	27.067	-0.251	-0.050	-0.008	0.256
-37.786	-4.316	25.122	-37.692	-4.098	25.006	-0.094	-0.218	0.116	0.264
-42.160	5.865	25.130	-41.925	5.818	24.956	-0.235	0.047	0.174	0.296
-42.214	11.014	27.085	-41.972	11.105	27.102	-0.242	-0.091	-0.017	0.259
-42.252	15.551	22.026	-42.014	15.785	21.879	-0.238	-0.234	0.147	0.364
-42.273	19.547	8.571	-42.045	19.651	8.413	-0.228	-0.104	0.158	0.297
-40.525	1.486	20.285	-40.441	1.478	20.132	-0.084	0.008	0.153	0.175
-45.173	0.074	21.794	-44.939	0.193	21.535	-0.234	-0.119	0.259	0.368
-40.597	-2.667	21.500	-40.478	-2.494	21.324	-0.119	-0.173	0.176	0.274
45.123	-41.239	14.936	44.845	-41.089	14.965	0.278	-0.150	-0.029	0.317
42.574	-45.898	13.211	42.276	-45.790	13.134	0.298	-0.108	0.077	0.326
40.430	-49.821	9.815	40.133	-49.714	9.668	0.297	-0.107	0.147	0.348
38.934	-52.569	5.105	38.654	-52.422	4.895	0.280	-0.147	0.210	0.380
31.902	-44.836	5.180	31.778	-44.527	4.874	0.124	-0.309	0.306	0.453

34.893	-43.662	9.917	34.628	-43.411	9.641	0.265	-0.251	0.276	0.458
39.103	-42.010	13.324	38.767	-41.798	13.135	0.336	-0.212	0.189	0.440
44.103	-40.048	14.962	43.765	-39.842	14.884	0.338	-0.206	0.078	0.404
44.058	-38.407	14.975	43.727	-38.184	14.881	0.331	-0.223	0.094	0.410
38.973	-36.696	13.326	38.633	-36.468	13.150	0.340	-0.228	0.176	0.446
34.647	-35.238	9.955	34.469	-35.061	9.604	0.178	-0.177	0.351	0.431
31.601	-34.213	5.197	31.553	-34.072	4.870	0.048	-0.141	0.327	0.359
38.256	-25.920	5.200	38.042	-25.860	4.900	0.214	-0.060	0.300	0.374
39.937	-28.685	9.919	39.642	-28.487	9.673	0.295	-0.198	0.246	0.432
42.273	-32.520	13.380	41.968	-32.310	13.132	0.305	-0.210	0.248	0.445
45.086	-37.130	14.947	44.759	-36.892	14.896	0.327	-0.238	0.051	0.407
46.693	-36.794	15.025	46.384	-36.562	14.931	0.309	-0.232	0.094	0.397
47.498	-31.477	13.359	47.199	-31.210	13.233	0.299	-0.267	0.126	0.420
48.161	-27.122	9.841	47.873	-26.785	9.722	0.288	-0.337	0.119	0.459
48.648	-23.954	5.160	48.346	-23.676	4.952	0.302	-0.278	0.208	0.460
38.934	-52.569	5.105	38.655	-52.421	4.895	0.279	-0.148	0.210	0.380
40.431	-49.820	9.813	40.132	-49.714	9.668	0.299	-0.106	0.145	0.349
42.575	-45.898	13.210	42.276	-45.790	13.134	0.299	-0.108	0.076	0.327
45.123	-41.239	14.936	44.845	-41.089	14.962	0.278	-0.150	-0.026	0.317
47.422	-37.036	14.964	47.177	-36.821	14.968	0.245	-0.215	-0.004	0.326
49.951	-32.394	13.178	49.756	-32.097	13.182	0.195	-0.297	-0.004	0.355
52.075	-28.501	9.784	51.924	-28.129	9.740	0.151	-0.372	0.044	0.403
53.590	-25.742	5.112	53.413	-25.405	4.945	0.177	-0.337	0.167	0.416
60.356	-33.677	5.034	60.471	-33.308	4.974	-0.115	-0.369	0.060	0.391
58.515	-34.870	9.487	57.519	-34.461	9.755	0.996	-0.409	-0.268	1.110
53.430	-36.390	13.068	53.322	-36.104	13.239	0.108	-0.286	-0.171	0.350
48.563	-38.299	14.945	48.278	-38.078	14.921	0.285	-0.221	0.024	0.362
48.599	-39.935	14.916	48.319	-39.738	14.933	0.280	-0.197	-0.017	0.342
53.541	-41.595	13.028	53.462	-41.472	13.258	0.079	-0.123	-0.230	0.273
57.657	-42.975	9.629	57.745	-42.915	9.774	-0.088	-0.060	-0.145	0.180
60.532	-43.938	4.998	60.732	-43.920	4.974	-0.200	-0.018	0.024	0.202
54.152	-51.950	4.989	54.063	-52.152	4.942	0.089	0.202	0.047	0.225
52.571	-49.372	9.637	52.439	-49.496	9.737	0.132	0.124	-0.100	0.207
50.319	-45.695	13.098	50.093	-45.650	13.221	0.226	-0.045	-0.123	0.261
47.575	-41.207	14.879	47.282	-41.034	14.935	0.293	-0.173	-0.056	0.345
45.976	-41.542	14.952	45.653	-41.360	14.929	0.323	-0.182	0.023	0.371
45.189	-46.774	13.177	44.843	-46.689	13.192	0.346	-0.085	-0.015	0.357
44.536	-51.128	9.744	44.176	-51.077	9.667	0.360	-0.051	0.077	0.372
44.085	-54.165	5.051	43.706	-54.180	4.918	0.379	0.015	0.133	0.402
53.590	-25.742	5.113	53.414	-25.404	4.945	0.176	-0.338	0.168	0.417
52.075	-28.503	9.786	51.925	-28.129	9.740	0.150	-0.374	0.046	0.405
49.946	-32.400	13.165	49.756	-32.098	13.183	0.190	-0.302	-0.018	0.357
47.422	-37.036	14.964	47.176	-36.822	14.968	0.246	-0.214	-0.004	0.326
32.469	-49.590	0.711	32.119	-49.366	0.396	0.350	-0.224	0.315	0.522
36.807	-53.876	0.502	36.448	-53.670	0.257	0.359	-0.206	0.245	0.481
45.273	-56.060	0.900	44.917	-55.943	0.694	0.356	-0.117	0.206	0.427
54.348	-53.590	1.964	54.187	-53.725	1.027	0.161	0.135	0.937	0.960
60.434	-47.500	2.009	60.531	-47.561	1.269	-0.097	0.061	0.740	0.749

62.701	-39.406	2.016	62.832	-39.216	1.246	-0.131	-0.190	0.770	0.804
5.513	29.201	-10.191	5.457	29.357	-10.246	0.056	-0.156	0.055	0.174
2.146	29.211	-10.193	2.110	29.344	-10.250	0.036	-0.133	0.057	0.149
2.134	26.019	0.317	2.110	26.181	0.206	0.024	-0.162	0.111	0.198
-1.221	29.159	-10.213	-1.239	29.334	-10.257	0.018	-0.175	0.044	0.181
5.528	20.048	-12.273	5.460	20.114	-12.443	0.068	-0.066	0.170	0.195
2.141	23.195	-1.755	2.111	23.240	-1.976	0.030	-0.045	0.221	0.227
2.161	20.057	-12.283	2.113	20.099	-12.439	0.048	-0.042	0.156	0.169
-1.206	20.053	-12.289	-1.234	20.114	-12.444	0.028	-0.061	0.155	0.169
7.890	27.512	-10.186	7.995	27.395	-10.264	-0.105	0.117	0.078	0.176
7.929	24.984	-10.172	7.969	24.884	-10.274	-0.040	0.100	0.102	0.149
3.615	24.978	0.304	3.726	24.879	0.167	-0.111	0.099	0.137	0.202
7.923	22.461	-10.177	7.962	22.372	-10.276	-0.039	0.089	0.099	0.139
-4.306	27.499	-12.365	-4.298	27.395	-12.482	-0.008	0.104	0.117	0.157
-0.198	24.974	-1.804	-0.208	24.879	-1.981	0.010	0.095	0.177	0.201
-4.285	24.974	-12.372	-4.290	24.883	-12.488	0.005	0.091	0.116	0.148
-4.297	22.448	-12.367	-4.313	22.372	-12.479	0.016	0.076	0.112	0.137
-9.104	4.915	-1.748	-9.095	4.943	-1.917	-0.009	-0.028	0.169	0.172
-9.184	4.945	10.039	-9.129	4.955	9.804	-0.055	-0.010	0.235	0.242
-0.654	10.339	10.052	-0.669	10.340	9.806	0.015	-0.001	0.246	0.246
-0.635	10.350	-1.732	-0.667	10.346	-1.913	0.032	0.004	0.181	0.184
8.521	6.081	-1.719	8.483	6.125	-1.909	0.038	-0.044	0.190	0.199
8.463	6.052	10.068	8.429	6.084	9.813	0.034	-0.032	0.255	0.259
9.921	-3.311	10.065	9.853	-3.257	9.806	0.068	-0.054	0.259	0.273
9.963	-3.315	1.227	9.876	-3.259	1.017	0.087	-0.056	0.210	0.234
0.040	-10.580	1.211	-0.016	-10.432	1.013	0.056	-0.148	0.198	0.253
0.025	-10.568	10.050	-0.017	-10.439	9.803	0.042	-0.129	0.247	0.282
-9.948	-3.351	10.035	-9.885	-3.259	9.800	-0.063	-0.092	0.235	0.260
-9.860	-3.326	1.194	-9.871	-3.253	1.009	0.011	-0.073	0.185	0.199
10.546	-10.053	4.171	10.606	-10.122	3.939	-0.060	0.069	0.232	0.249
-10.982	-9.492	4.137	-11.080	-9.492	3.938	0.098	0.000	0.199	0.222
-14.413	1.806	1.190	-14.512	1.873	1.012	0.099	-0.067	0.178	0.214
-8.216	11.880	4.149	-8.297	12.018	3.949	0.081	-0.138	0.200	0.256
3.411	14.072	1.222	3.427	14.269	1.022	-0.016	-0.197	0.200	0.281
12.835	6.885	4.180	12.939	6.985	3.948	-0.104	-0.100	0.232	0.273
1.911	2.092	-16.542	1.842	2.124	-16.817	0.069	-0.032	0.275	0.285
-3.765	3.757	-16.601	-3.801	3.785	-16.859	0.036	-0.028	0.258	0.262
-3.839	-4.175	-16.622	-3.880	-4.104	-16.888	0.041	-0.071	0.266	0.279
3.736	-4.022	-16.667	3.650	-3.958	-16.897	0.086	-0.064	0.230	0.254
-0.376	0.180	-21.106	-0.376	0.180	-21.106	0.000	0.000	0.000	
-9.376	-8.614	12.362	-9.355	-8.513	12.219	-0.021	-0.101	0.143	0.177
-12.027	3.440	12.380	-11.979	3.477	12.248	-0.048	-0.037	0.132	0.145
-0.962	11.933	12.449	-0.966	11.910	12.268	0.004	0.023	0.181	0.182
11.205	4.878	12.525	11.127	4.882	12.357	0.078	-0.004	0.168	0.186
10.565	-7.064	12.445	10.475	-6.993	12.245	0.090	-0.071	0.200	0.230
0.434	-12.882	12.369	0.396	-12.768	12.154	0.038	-0.114	0.215	0.247
-0.430	-14.578	7.239	-0.476	-14.631	7.007	0.046	0.053	0.232	0.243
7.074	-46.831	7.100	6.932	-46.531	6.856	0.142	-0.300	0.244	0.412

7.035	-36.822	7.103	6.921	-36.580	6.863	0.114	-0.242	0.240	0.359
6.959	-26.817	7.107	6.942	-26.630	6.866	0.017	-0.187	0.241	0.306
6.861	-16.811	7.110	6.995	-16.679	6.870	-0.134	-0.132	0.240	0.305
4.453	-17.773	7.105	4.388	-17.636	6.869	0.065	-0.137	0.236	0.281
4.562	-27.496	7.104	4.379	-27.304	6.865	0.183	-0.192	0.239	0.357
4.615	-37.218	7.101	4.408	-36.973	6.861	0.207	-0.245	0.240	0.401
4.643	-46.941	7.096	4.353	-46.641	6.859	0.290	-0.300	0.237	0.480
-4.086	-46.966	10.030	-3.939	-46.656	9.785	-0.147	-0.310	0.245	0.422
-4.138	-37.279	10.030	-3.994	-37.024	9.786	-0.144	-0.255	0.244	0.381
-4.093	-27.597	10.034	-3.955	-27.394	9.791	-0.138	-0.203	0.243	0.346
-4.070	-17.911	10.036	-3.946	-17.763	9.795	-0.124	-0.148	0.241	0.309
-8.007	-16.171	4.139	-8.094	-16.031	3.937	0.087	-0.140	0.202	0.261
-8.044	-26.374	4.137	-8.090	-26.175	3.932	0.046	-0.199	0.205	0.289
-8.095	-36.574	4.135	-8.077	-36.320	3.929	-0.018	-0.254	0.206	0.328
-8.065	-46.774	4.131	-8.069	-46.462	3.925	0.004	-0.312	0.206	0.374
-6.015	-49.985	7.529	-6.062	-50.276	7.300	0.047	0.291	0.229	0.374
4.823	-50.669	10.781	5.624	-50.297	10.519	-0.801	-0.372	0.262	0.921
5.720	-46.603	12.495	5.619	-46.307	12.328	0.101	-0.296	0.167	0.355
5.734	-37.559	12.468	5.638	-37.313	12.303	0.096	-0.246	0.165	0.311
5.631	-28.516	12.467	5.547	-28.320	12.388	0.084	-0.196	0.079	0.227
5.847	-17.547	12.467	5.774	-17.412	12.306	0.073	-0.135	0.161	0.222
-6.143	-17.003	12.367	-6.149	-16.860	12.244	0.006	-0.143	0.123	0.189
-6.252	-27.406	12.432	-6.267	-27.204	12.322	0.015	-0.202	0.110	0.231
-6.266	-36.224	12.389	-6.291	-35.974	12.295	0.025	-0.250	0.094	0.269
-5.795	-47.977	12.475	-5.833	-47.661	12.333	0.038	-0.316	0.142	0.348
63.098	-85.778	0.636	62.621	-85.322	0.231	0.477	-0.456	0.405	0.774
51.671	-86.159	0.425	51.256	-85.688	0.166	0.415	-0.471	0.259	0.679
30.926	-85.702	0.201	30.626	-85.214	0.107	0.300	-0.488	0.094	0.580
26.934	-77.988	0.073	26.665	-77.537	-0.008	0.269	-0.451	0.081	0.532
40.120	-79.699	0.144	39.776	-79.252	0.100	0.344	-0.447	0.044	0.565
56.553	-76.293	0.345	56.121	-75.882	0.244	0.432	-0.411	0.101	0.605
61.192	-66.989	0.328	60.744	-66.635	0.159	0.448	-0.354	0.169	0.596
47.203	-70.256	0.157	46.829	-69.870	0.005	0.374	-0.386	0.152	0.559
37.680	-65.870	0.121	37.363	-65.498	0.045	0.317	-0.372	0.076	0.495
24.031	-65.555	-0.121	23.790	-65.172	-0.107	0.241	-0.383	-0.014	0.453
20.056	-53.457	-0.087	19.850	-53.137	-0.103	0.206	-0.320	0.016	0.381
15.280	-46.337	-0.026	15.108	-46.050	-0.083	0.172	-0.287	0.057	0.339
23.689	-45.582	-0.060	23.471	-45.308	-0.127	0.218	-0.274	0.067	0.357
14.917	-35.402	-0.056	14.759	-35.177	-0.095	0.158	-0.225	0.039	0.278
15.771	-25.441	-0.041	15.619	-25.272	-0.132	0.152	-0.169	0.091	0.245
25.686	-28.367	0.004	25.476	-28.192	-0.150	0.210	-0.175	0.154	0.314
33.666	-23.366	-0.021	33.417	-23.227	-0.163	0.249	-0.139	0.142	0.319
61.758	-24.482	0.164	61.349	-24.365	-0.011	0.409	-0.117	0.175	0.460
68.149	-34.996	0.255	67.696	-34.827	0.117	0.453	-0.169	0.138	0.503
65.365	-54.970	0.251	64.907	-54.689	0.173	0.458	-0.281	0.078	0.543
68.974	-6.545	0.216	68.544	-6.535	0.056	0.430	-0.010	0.160	0.459
66.119	18.450	0.233	65.732	18.322	0.175	0.387	0.128	0.058	0.412
52.212	19.012	0.031	51.902	18.896	-0.017	0.310	0.116	0.048	0.334

38.337	18.748	-0.341	38.103	18.649	-0.019	0.234	0.099	-0.322	0.411
24.982	19.058	0.062	24.824	18.970	-0.064	0.158	0.088	0.126	0.220
27.076	28.519	0.012	26.915	28.376	-0.055	0.161	0.143	0.067	0.225
34.218	26.865	-0.034	34.017	26.723	-0.047	0.201	0.142	0.013	0.247
45.962	25.941	0.020	45.693	25.794	-0.033	0.269	0.147	0.053	0.311
45.636	34.482	0.179	45.378	34.287	-0.064	0.258	0.195	0.243	0.404
29.657	39.379	0.031	29.494	39.173	-0.033	0.163	0.206	0.064	0.271
17.298	42.209	0.096	17.206	41.999	-0.068	0.092	0.210	0.164	0.282
7.060	39.328	0.115	7.023	39.145	-0.013	0.037	0.183	0.128	0.227
10.221	49.384	0.011	10.174	49.140	-0.066	0.047	0.244	0.077	0.260
22.905	52.358	0.128	22.793	52.086	-0.027	0.112	0.272	0.155	0.332
43.200	55.630	0.242	42.978	55.319	0.076	0.222	0.311	0.166	0.416
66.395	54.323	0.481	66.043	53.996	0.176	0.352	0.327	0.305	0.569
67.001	38.346	0.387	66.629	38.108	0.124	0.372	0.238	0.263	0.514
-12.227	40.781	0.044	-12.155	40.609	-0.070	-0.072	0.172	0.114	0.219
-22.779	17.475	0.066	-22.671	17.445	-0.070	-0.108	0.030	0.136	0.176
-24.095	30.665	-0.003	-23.967	30.563	-0.115	-0.128	0.102	0.112	0.199
-31.266	25.972	0.070	-31.105	25.903	-0.113	-0.161	0.069	0.183	0.254
-42.998	26.621	0.144	-42.770	26.559	-0.121	-0.228	0.062	0.265	0.355
-50.495	30.467	0.188	-50.220	30.393	0.007	-0.275	0.074	0.181	0.338
-40.465	46.027	0.097	-40.231	45.856	-0.006	-0.234	0.171	0.103	0.308
-47.598	54.577	0.160	-47.315	54.366	0.064	-0.283	0.211	0.096	0.366
-75.608	53.763	0.330	-75.170	53.585	0.218	-0.438	0.178	0.112	0.486
-75.807	37.481	0.198	-75.383	37.394	0.150	-0.424	0.087	0.048	0.436
-74.572	19.324	0.109	-74.176	19.336	0.143	-0.396	-0.012	-0.034	0.398
-57.100	25.245	0.109	-56.794	25.207	-0.025	-0.306	0.038	0.134	0.336
-66.126	11.928	0.135	-65.785	11.973	0.021	-0.341	-0.045	0.114	0.363
-68.625	-1.133	0.193	-68.284	-1.012	0.034	-0.341	-0.121	0.159	0.396
-76.969	-10.836	0.114	-76.591	-10.652	0.077	-0.378	-0.184	0.037	0.422
-76.811	-29.311	0.109	-76.453	-29.025	0.067	-0.358	-0.286	0.042	0.460
-62.549	-24.894	0.155	-62.264	-24.648	-0.010	-0.285	-0.246	0.165	0.411
-49.865	-21.918	0.032	-49.651	-21.701	-0.133	-0.214	-0.217	0.165	0.346
-35.533	-26.603	0.090	-35.401	-26.375	-0.129	-0.132	-0.228	0.219	0.343
-22.788	-18.107	0.001	-22.717	-17.940	-0.054	-0.071	-0.167	0.055	0.190
-27.780	-37.057	-0.102	-27.702	-36.778	-0.161	-0.078	-0.279	0.059	0.296
-13.635	-51.124	-0.062	-13.650	-50.783	-0.110	0.015	-0.341	0.048	0.345
-5.126	-60.170	-0.124	-5.198	-59.787	-0.072	0.072	-0.383	-0.052	0.393
-6.351	-70.974	-0.121	-6.428	-70.529	-0.023	0.077	-0.445	-0.098	0.462
-7.680	-86.195	0.020	-7.765	-85.662	-0.019	0.085	-0.533	0.039	0.541
-27.103	-90.809	0.091	-27.084	-90.234	0.113	-0.019	-0.575	-0.022	0.576
-40.797	-88.583	0.127	-40.699	-88.004	0.114	-0.098	-0.579	0.013	0.587
-53.561	-82.185	0.101	-53.385	-81.628	0.195	-0.176	-0.557	-0.094	0.592
-62.760	-90.816	0.348	-62.542	-90.203	0.227	-0.218	-0.613	0.121	0.662
-77.093	-86.132	0.379	-76.790	-85.530	0.298	-0.303	-0.602	0.081	0.679
-75.458	-64.556	0.178	-75.144	-64.077	0.201	-0.314	-0.479	-0.023	0.573
-71.872	-44.284	0.134	-71.555	-43.921	0.104	-0.317	-0.363	0.030	0.483
-65.706	-56.182	0.177	-65.435	-55.758	0.078	-0.271	-0.424	0.099	0.513
-62.067	-65.969	0.187	-61.829	-65.494	0.092	-0.238	-0.475	0.095	0.540

-50.359	-58.893	0.073	-50.178	-58.471	0.028	-0.181	-0.422	0.045	0.462
-50.098	-72.950	0.091	-49.932	-72.449	0.019	-0.166	-0.501	0.072	0.532
-13.986	-37.978	-16.596	-14.008	-37.708	-16.859	0.022	-0.270	0.263	0.377
-14.403	-16.580	-16.561	-14.401	-16.429	-16.918	-0.002	-0.151	0.357	0.388
-13.621	16.097	-16.488	-13.590	16.065	-16.862	-0.031	0.032	0.374	0.376
-13.466	29.305	-16.485	-13.423	29.199	-16.755	-0.043	0.106	0.270	0.293
14.591	31.596	-16.512	14.482	31.450	-16.829	0.109	0.146	0.317	0.365
15.468	23.891	-16.493	15.346	23.786	-16.806	0.122	0.105	0.313	0.352
15.743	12.200	-16.512	15.608	12.161	-16.865	0.135	0.039	0.353	0.380
59.938	4.332	-16.325	59.549	4.291	-16.706	0.389	0.041	0.381	0.547
58.394	-9.942	-16.325	57.999	-9.902	-16.725	0.395	-0.040	0.400	0.564
48.908	-15.244	-16.416	48.559	-15.165	-16.778	0.349	-0.079	0.362	0.509
36.493	-9.663	-16.448	36.220	-9.602	-16.795	0.273	-0.061	0.347	0.446
30.732	-17.693	-16.480	30.482	-17.582	-16.853	0.250	-0.111	0.373	0.462
13.270	-15.193	-16.564	13.120	-15.077	-16.904	0.150	-0.116	0.340	0.390
19.523	2.794	-4.526	19.373	2.802	-4.342	0.150	-0.008	-0.184	0.238
28.906	7.211	-4.587	28.707	7.185	-4.321	0.199	0.026	-0.266	0.333
34.434	2.959	-4.603	34.202	2.950	-4.269	0.232	0.009	-0.334	0.406
41.184	7.348	-4.524	40.918	7.308	-4.236	0.266	0.040	-0.288	0.394
46.418	2.167	-4.276	46.117	2.152	-4.302	0.301	0.015	0.026	0.303
52.008	8.392	-4.150	51.684	8.336	-4.253	0.324	0.056	0.103	0.345
50.842	-3.206	0.233	50.517	-3.196	-0.012	0.325	-0.010	0.245	0.407
40.319	-3.013	0.151	40.053	-2.994	-0.102	0.266	-0.019	0.253	0.368
28.627	-2.835	0.091	28.426	-2.804	-0.144	0.201	-0.031	0.235	0.311
16.937	-2.040	0.050	16.802	-2.004	-0.143	0.135	-0.036	0.193	0.239
18.562	-9.367	1.643	18.412	-9.290	1.387	0.150	-0.077	0.256	0.306
24.719	-6.526	1.624	24.539	-6.471	1.405	0.180	-0.055	0.219	0.289
25.841	-14.832	1.775	25.644	-14.732	1.501	0.197	-0.100	0.274	0.352
18.807	-12.090	-3.712	18.644	-12.281	-3.908	0.163	0.191	0.196	0.319
25.703	-16.765	1.515	25.504	-16.514	0.450	0.199	-0.251	1.065	1.112
33.005	-3.783	-3.752	32.771	-3.930	-3.965	0.234	0.147	0.213	0.348
40.028	-3.818	-2.987	39.757	-3.944	-3.214	0.271	0.126	0.227	0.375
52.651	-3.775	-4.242	52.309	-3.937	-4.479	0.342	0.162	0.237	0.446
54.539	0.327	-8.513	55.092	0.024	-8.731	-0.553	0.303	0.218	0.668
56.636	6.956	-9.254	56.428	7.858	-9.469	0.208	-0.902	0.215	0.950
59.460	12.510	-0.436	59.102	12.387	-0.620	0.358	0.123	0.184	0.421
49.246	13.494	-1.459	48.943	13.231	-1.391	0.303	0.263	-0.068	0.407
39.408	12.949	-1.449	39.160	12.566	-1.364	0.248	0.383	-0.085	0.465

### 3D-Tol Data from CMM for ThermoJet Aluminium Casting

MEAS X	MEAS Y	MEAS Z	Pattern X	Pattern Y	Pattern Z	DIF X	DIF Y	DIF Z	TOT DIF
53.776	58.683	-5.813	53.428	58.673	-5.778	0.348	0.010	-0.035	0.350
37.230	58.697	-5.846	36.973	58.640	-5.785	0.257	0.057	-0.061	0.270
20.685	58.681	-5.879	20.519	58.644	-5.793	0.166	0.037	-0.086	0.191
4.140	58.727	-5.912	4.067	58.623	-5.800	0.073	0.104	-0.112	0.170
-12.405	58.745	-5.946	-12.387	58.590	-5.808	-0.018	0.155	-0.138	0.208

-28.949	58.798	-5.979	-28.838	58.578	-5.815	-0.111	0.220	-0.164	0.296
-45.494	58.766	-6.012	-45.291	58.617	-5.821	-0.203	0.149	-0.191	0.316
-62.039	58.717	-6.045	-61.743	58.614	-5.829	-0.296	0.103	-0.216	0.380
-79.807	41.051	-6.101	-79.708	40.861	-5.846	-0.099	0.190	-0.255	0.333
-79.697	24.508	-6.115	-79.571	24.408	-5.853	-0.126	0.100	-0.262	0.307
-80.559	7.961	-6.131	-79.427	7.955	-5.860	-1.132	0.006	-0.271	1.164
-79.983	-8.582	-6.146	-79.309	-8.495	-5.867	-0.674	-0.087	-0.279	0.735
-79.839	-25.128	-6.161	-79.241	-24.949	-5.874	-0.598	-0.179	-0.287	0.687
-80.044	-41.672	-6.176	-79.228	-41.402	-5.881	-0.816	-0.270	-0.295	0.908
-79.474	-58.217	-6.190	-79.281	-57.853	-5.888	-0.193	-0.364	-0.302	0.511
-79.612	-74.760	-6.205	-79.417	-74.307	-5.895	-0.195	-0.453	-0.310	0.583
-62.046	-92.389	-6.181	-61.777	-92.259	-5.894	-0.269	-0.130	-0.287	0.414
-45.501	-92.370	-6.147	-45.323	-92.198	-5.886	-0.178	-0.172	-0.261	0.360
-28.955	-92.297	-6.113	-28.871	-92.115	-5.878	-0.084	-0.182	-0.235	0.309
-12.411	-92.574	-6.080	-12.419	-92.054	-5.870	0.008	-0.520	-0.210	0.560
4.134	-92.287	-6.047	4.034	-92.051	-5.863	0.100	-0.236	-0.184	0.316
20.678	-92.407	-6.014	20.487	-92.156	-5.856	0.191	-0.251	-0.158	0.353
37.224	-92.378	-5.980	36.939	-92.242	-5.849	0.285	-0.136	-0.131	0.341
53.768	-92.368	-5.948	53.391	-92.251	-5.841	0.377	-0.117	-0.107	0.409
71.201	-74.768	-5.893	71.279	-74.344	-5.823	-0.078	-0.424	-0.070	0.437
71.210	-58.224	-5.880	71.228	-57.891	-5.815	-0.018	-0.333	-0.065	0.340
71.313	-41.680	-5.864	71.261	-41.439	-5.808	0.052	-0.241	-0.056	0.253
71.385	-25.135	-5.848	71.294	-24.984	-5.803	0.091	-0.151	-0.045	0.182
71.391	-8.591	-5.832	71.317	-8.533	-5.796	0.074	-0.058	-0.036	0.101
71.207	7.955	-5.818	71.235	7.921	-5.790	-0.028	0.034	-0.028	0.053
71.167	24.500	-5.802	71.191	24.374	-5.783	-0.024	0.126	-0.019	0.130
71.276	41.044	-5.788	71.210	40.825	-5.776	0.066	0.219	-0.012	0.229
-69.815	43.731	8.630	-69.452	43.531	8.724	-0.363	0.200	-0.094	0.425
-64.764	43.732	8.728	-64.430	43.529	8.742	-0.334	0.203	-0.014	0.391
-64.764	48.782	8.653	-64.430	48.552	8.732	-0.334	0.230	-0.079	0.413
-69.814	48.781	8.538	-69.452	48.552	8.705	-0.362	0.229	-0.167	0.460
-67.683	46.377	8.569	-67.332	46.161	8.668	-0.351	0.216	-0.099	0.424
-71.716	43.733	6.543	-71.471	43.533	6.713	-0.245	0.200	-0.170	0.359
-71.728	48.783	6.547	-71.512	48.556	6.715	-0.216	0.227	-0.168	0.356
-69.807	50.518	6.556	-69.449	50.320	6.719	-0.358	0.198	-0.163	0.440
-64.757	50.541	6.567	-64.426	50.350	6.721	-0.331	0.191	-0.154	0.412
-64.756	42.213	6.561	-64.428	41.991	6.714	-0.328	0.222	-0.153	0.425
-69.807	42.193	6.549	-69.451	41.985	6.712	-0.356	0.208	-0.163	0.444
-63.397	48.784	6.570	-63.129	48.553	6.720	-0.268	0.231	-0.150	0.384
-63.361	43.735	6.569	-63.104	43.531	6.718	-0.257	0.204	-0.149	0.361
-64.759	-14.340	4.104	-64.443	-14.220	3.992	-0.316	-0.120	0.112	0.356
-69.809	-14.339	3.991	-69.466	-14.218	4.020	-0.343	-0.121	-0.029	0.365
-69.808	-19.388	4.033	-69.467	-19.241	4.053	-0.341	-0.147	-0.020	0.372
-64.759	-19.389	4.151	-64.444	-19.241	4.043	-0.315	-0.148	0.108	0.364
-67.930	-16.766	3.974	-67.597	-16.633	3.964	-0.333	-0.133	0.010	0.358
-69.804	-12.662	3.132	-69.462	-12.673	3.345	-0.342	0.011	-0.213	0.403
-64.754	-12.670	3.144	-64.441	-12.670	3.347	-0.313	0.000	-0.203	0.373
-63.076	-14.338	3.149	-62.845	-14.219	3.347	-0.231	-0.119	-0.198	0.327

-63.097	-19.387	3.146	-62.848	-19.241	3.345	-0.249	-0.146	-0.199	0.351
-64.754	-21.028	3.137	-64.440	-21.008	3.340	-0.314	-0.020	-0.203	0.374
-69.804	-20.994	3.125	-69.465	-21.009	3.339	-0.339	0.015	-0.214	0.401
-71.422	-19.389	3.119	-71.193	-19.238	3.338	-0.229	-0.151	-0.219	0.351
-71.414	-14.339	3.123	-71.194	-14.216	3.341	-0.220	-0.123	-0.218	0.333
-64.772	-77.469	8.556	-64.461	-76.995	8.709	-0.311	-0.474	-0.153	0.587
-69.821	-77.469	8.452	-69.484	-76.994	8.679	-0.337	-0.475	-0.227	0.625
-69.821	-82.519	8.353	-69.484	-82.017	8.653	-0.337	-0.502	-0.300	0.675
-64.771	-82.518	8.461	-64.461	-82.017	8.675	-0.310	-0.501	-0.214	0.627
-69.814	-75.844	6.441	-69.480	-75.623	6.667	-0.334	-0.221	-0.226	0.460
-64.763	-75.813	6.453	-64.459	-75.625	6.671	-0.304	-0.188	-0.218	0.418
-63.299	-77.466	6.457	-63.017	-76.993	6.670	-0.282	-0.473	-0.213	0.590
-63.321	-82.515	6.455	-63.028	-82.017	6.667	-0.293	-0.498	-0.212	0.616
-64.764	-84.142	6.446	-64.458	-83.958	6.663	-0.306	-0.184	-0.217	0.418
-69.814	-84.117	6.434	-69.484	-83.934	6.661	-0.330	-0.183	-0.227	0.440
-71.618	-82.517	6.427	-71.369	-82.014	6.661	-0.249	-0.503	-0.234	0.608
-71.619	-77.467	6.432	-71.373	-76.992	6.664	-0.246	-0.475	-0.232	0.583
-2.473	43.730	4.409	-2.491	43.515	4.265	0.018	0.215	0.144	0.259
2.578	43.731	4.414	2.530	43.514	4.260	0.048	0.217	0.154	0.270
2.579	48.781	4.333	2.530	48.537	4.272	0.049	0.244	0.061	0.256
-2.472	48.781	4.337	-2.492	48.538	4.275	0.020	0.243	0.062	0.251
-0.633	46.766	4.287	-0.662	46.533	4.197	0.029	0.233	0.090	0.251
-4.162	43.733	2.049	-4.174	43.518	2.140	0.012	0.215	-0.091	0.233
-4.169	48.783	2.055	-4.185	48.540	2.143	0.016	0.243	-0.088	0.259
2.586	42.213	2.066	2.532	42.049	2.141	0.054	0.164	-0.075	0.189
-2.464	42.204	2.055	-2.491	42.044	2.140	0.027	0.160	-0.085	0.184
4.085	48.783	2.078	4.078	48.539	2.147	0.007	0.244	-0.069	0.253
4.077	43.734	2.075	4.085	43.516	2.146	-0.008	0.218	-0.071	0.229
-2.465	50.460	2.062	-2.488	50.316	2.144	0.023	0.144	-0.082	0.167
2.586	50.450	2.074	2.533	50.317	2.148	0.053	0.133	-0.074	0.161
-64.694	36.168	-1.440	-64.477	36.102	-1.238	-0.217	0.066	-0.202	0.304
-53.986	46.889	-1.406	-53.839	46.769	-1.228	-0.147	0.120	-0.178	0.260
-47.050	46.712	-1.398	-46.786	46.535	-1.226	-0.264	0.177	-0.172	0.361
-37.109	35.228	-1.388	-36.059	35.955	-1.226	-1.050	-0.727	-0.162	1.287
-40.837	29.120	-1.397	-40.800	28.849	-1.228	-0.037	0.271	-0.169	0.321
-48.127	36.116	-1.406	-47.915	35.941	-1.228	-0.212	0.175	-0.178	0.328
-36.292	30.167	-1.773	-35.629	29.526	-1.605	-0.663	0.641	-0.168	0.937
-53.991	34.987	-1.425	-53.850	34.942	-1.234	-0.141	0.045	-0.191	0.241
-58.735	30.204	-1.439	-58.564	30.182	-1.236	-0.171	0.022	-0.203	0.266
-65.341	29.574	-1.347	-65.062	29.413	-1.141	-0.279	0.161	-0.206	0.383
-61.327	33.537	-4.148	-61.033	33.384	-4.280	-0.294	0.153	0.132	0.357
-56.758	38.291	-4.113	-56.490	38.112	-4.279	-0.268	0.179	0.166	0.363
-50.262	43.695	-4.139	-50.029	43.483	-4.252	-0.233	0.212	0.113	0.335
-44.702	38.647	-4.164	-44.501	38.463	-4.246	-0.201	0.184	0.082	0.285
-40.026	33.837	-4.122	-39.853	33.679	-4.323	-0.173	0.158	0.201	0.308
49.712	42.163	5.949	49.402	42.122	5.929	0.310	0.041	0.020	0.313
42.979	42.186	5.936	42.705	42.114	5.926	0.274	0.072	0.010	0.284
54.643	30.260	5.946	54.546	30.109	5.928	0.097	0.151	0.018	0.180

54.653	36.993	5.949	54.569	36.806	5.932	0.084	0.187	0.017	0.206
58.852	25.506	5.457	58.486	25.462	5.436	0.366	0.044	0.021	0.369
62.951	30.259	5.967	62.902	30.109	5.933	0.049	0.150	0.034	0.161
62.932	37.837	5.974	62.890	37.642	5.937	0.042	0.195	0.037	0.203
62.957	45.413	5.980	62.915	45.175	5.940	0.042	0.238	0.040	0.245
58.126	50.348	5.971	57.771	50.393	5.940	0.355	-0.045	0.031	0.359
50.553	50.402	5.957	50.237	50.376	5.936	0.316	0.026	0.021	0.318
42.977	50.442	5.941	42.705	50.397	5.932	0.272	0.045	0.009	0.276
38.003	46.204	5.206	37.910	45.969	5.212	0.093	0.235	-0.006	0.253
43.219	46.368	8.596	42.952	46.134	8.528	0.267	0.234	0.068	0.361
50.452	46.079	8.513	50.143	45.842	8.468	0.309	0.237	0.045	0.392
58.422	45.746	8.485	58.070	45.511	8.471	0.352	0.235	0.014	0.424
59.163	37.482	8.464	58.803	37.291	8.457	0.360	0.191	0.007	0.408
59.039	30.637	8.501	58.679	30.484	8.501	0.360	0.153	0.000	0.391
-30.873	49.014	16.751	-30.714	48.668	16.862	-0.159	0.346	-0.111	0.396
-30.862	46.052	11.761	-30.712	45.791	11.858	-0.150	0.261	-0.097	0.316
-30.852	43.112	6.755	-30.710	42.932	6.847	-0.142	0.180	-0.092	0.247
-30.843	40.155	1.764	-30.710	40.085	1.825	-0.133	0.070	-0.061	0.162
-27.054	40.192	1.750	-26.943	40.118	1.810	-0.111	0.074	-0.060	0.146
-27.065	43.150	6.742	-26.946	42.977	6.823	-0.119	0.173	-0.081	0.225
-27.075	46.106	11.738	-26.949	45.825	11.840	-0.126	0.281	-0.102	0.324
-27.085	49.049	16.738	-26.949	48.688	16.851	-0.136	0.361	-0.113	0.402
-23.296	49.053	16.744	-23.180	48.691	16.849	-0.116	0.362	-0.105	0.394
-23.287	46.079	11.760	-23.179	45.822	11.843	-0.108	0.257	-0.083	0.290
-23.277	43.143	6.752	-23.177	42.977	6.824	-0.100	0.166	-0.072	0.206
-23.267	40.208	1.745	-23.176	40.143	1.795	-0.091	0.065	-0.050	0.122
-16.954	45.511	1.773	-16.898	45.298	1.881	-0.056	0.213	-0.108	0.245
-16.969	47.618	9.290	-16.902	47.369	9.359	-0.067	0.249	-0.069	0.267
-16.984	49.792	16.788	-16.906	49.398	16.852	-0.078	0.394	-0.064	0.406
-11.934	49.766	16.805	-11.882	49.385	16.856	-0.052	0.381	-0.051	0.387
-11.919	47.598	9.305	-11.879	47.339	9.368	-0.040	0.259	-0.063	0.269
-11.904	45.445	1.801	-11.876	45.283	1.887	-0.028	0.162	-0.086	0.185
-8.400	49.580	7.476	-8.313	49.335	7.535	-0.087	0.245	-0.059	0.267
-30.869	51.408	15.111	-30.714	51.072	15.140	-0.155	0.336	-0.029	0.371
-30.858	52.724	9.403	-30.715	52.455	9.482	-0.143	0.269	-0.079	0.314
-30.846	53.988	3.682	-30.711	53.770	3.810	-0.135	0.218	-0.128	0.287
-24.113	53.943	3.685	-24.014	53.727	3.802	-0.099	0.216	-0.117	0.265
-24.125	52.717	9.416	-24.018	52.433	9.482	-0.107	0.284	-0.066	0.310
-24.136	51.463	15.140	-24.019	51.080	15.147	-0.117	0.383	-0.007	0.400
-17.403	51.503	15.166	-17.323	51.088	15.153	-0.080	0.415	0.013	0.423
-17.390	52.764	9.443	-17.323	52.456	9.491	-0.067	0.308	-0.048	0.319
-17.378	53.929	3.694	-17.320	53.717	3.804	-0.058	0.212	-0.110	0.245
-10.645	53.953	3.715	-10.621	53.752	3.817	-0.024	0.201	-0.102	0.227
-10.659	52.803	9.468	-10.625	52.491	9.503	-0.034	0.312	-0.035	0.316
-10.670	51.497	15.176	-10.627	51.111	15.161	-0.043	0.386	0.015	0.389
-33.411	48.921	9.563	-33.369	48.686	9.654	-0.042	0.235	-0.091	0.255
5.004	-63.175	18.735	4.960	-62.787	18.764	0.044	-0.388	-0.029	0.391
3.134	-63.169	11.659	3.163	-62.784	11.713	-0.029	-0.385	-0.054	0.390

1.286	-63.163	4.582	1.370	-62.781	4.659	-0.084	-0.382	-0.077	0.398
1.307	-69.895	4.570	1.388	-69.478	4.652	-0.081	-0.417	-0.082	0.433
3.158	-69.900	11.649	3.192	-69.481	11.702	-0.034	-0.419	-0.053	0.424
5.020	-69.906	18.725	5.005	-69.483	18.749	0.015	-0.423	-0.024	0.424
5.020	-76.642	18.718	5.026	-76.180	18.740	-0.006	-0.462	-0.022	0.462
3.182	-76.635	11.635	3.205	-76.177	11.696	-0.023	-0.458	-0.061	0.462
1.293	-76.629	4.565	1.391	-76.173	4.648	-0.098	-0.456	-0.083	0.473
1.271	-83.362	4.566	1.341	-82.869	4.658	-0.070	-0.493	-0.092	0.506
3.147	-83.368	11.638	3.195	-82.872	11.695	-0.048	-0.496	-0.057	0.502
5.027	-83.374	18.710	5.023	-82.875	18.738	0.004	-0.499	-0.028	0.500
7.497	-85.879	10.218	7.406	-85.643	10.303	0.091	-0.236	-0.085	0.267
7.722	-83.376	21.084	7.803	-82.875	21.197	-0.081	-0.501	-0.113	0.520
13.087	-83.368	11.616	13.142	-82.873	11.785	-0.055	-0.495	-0.169	0.526
18.383	-83.360	2.107	18.435	-82.871	2.346	-0.052	-0.489	-0.239	0.547
18.394	-75.782	2.119	18.420	-75.337	2.338	-0.026	-0.445	-0.219	0.497
13.099	-75.792	11.630	13.121	-75.342	11.776	-0.022	-0.450	-0.146	0.474
7.742	-75.799	21.104	7.798	-75.345	21.197	-0.056	-0.454	-0.093	0.467
7.046	-69.485	21.096	7.038	-69.065	21.132	0.008	-0.420	-0.036	0.421
9.479	-69.479	11.650	9.481	-69.062	11.742	-0.002	-0.417	-0.092	0.427
11.804	-69.471	2.173	11.881	-69.059	2.341	-0.077	-0.412	-0.168	0.451
11.893	-64.421	2.201	11.903	-64.037	2.348	-0.010	-0.384	-0.147	0.411
9.514	-64.428	11.665	9.514	-64.041	11.752	0.000	-0.387	-0.087	0.396
7.069	-64.437	21.109	7.051	-64.044	21.139	0.018	-0.393	-0.030	0.394
6.479	-60.955	10.985	6.397	-60.717	11.060	0.082	-0.238	-0.075	0.263
-30.441	-50.779	-5.336	-30.351	-50.339	-5.197	-0.090	-0.440	-0.139	0.470
-30.151	-55.274	-7.648	-30.064	-54.858	-7.589	-0.087	-0.416	-0.059	0.429
-29.916	-58.732	-11.710	-29.834	-58.447	-11.424	-0.082	-0.285	-0.286	0.412
-29.679	-62.273	-15.138	-29.650	-61.341	-15.558	-0.029	-0.932	0.420	1.022
-33.326	-63.798	-15.468	-33.522	-63.163	-15.638	0.196	-0.635	0.170	0.686
-35.868	-61.530	-11.764	-35.749	-61.169	-11.502	-0.119	-0.361	-0.262	0.462
-38.413	-59.267	-7.679	-38.355	-58.833	-7.686	-0.058	-0.434	0.007	0.438
-41.741	-56.293	-5.345	-41.733	-55.805	-5.262	-0.008	-0.488	-0.083	0.495
-46.092	-68.128	-5.505	-46.078	-67.724	-5.372	-0.014	-0.404	-0.133	0.426
-41.513	-67.915	-7.732	-41.513	-67.512	-7.810	0.000	-0.403	0.078	0.411
-38.011	-67.752	-11.734	-38.101	-67.355	-11.585	0.090	-0.397	-0.149	0.434
-34.631	-67.592	-15.421	-35.027	-67.212	-15.736	0.396	-0.380	0.315	0.633
-32.831	-71.099	-15.183	-33.211	-71.174	-15.768	0.380	0.075	0.585	0.701
-35.153	-73.592	-11.658	-35.336	-73.465	-11.622	0.183	-0.127	-0.036	0.226
-37.649	-76.262	-7.751	-37.649	-75.944	-7.890	0.000	-0.318	0.139	0.347
-40.772	-79.623	-5.514	-40.778	-79.318	-5.460	0.006	-0.305	-0.054	0.310
-29.769	-67.454	-16.168	-29.596	-67.041	-16.646	-0.173	-0.413	0.478	0.655
-27.042	-63.114	-14.757	-26.597	-62.019	-15.563	-0.445	-1.095	0.806	1.431
-25.244	-59.805	-11.684	-25.203	-59.470	-11.426	-0.041	-0.335	-0.258	0.425
-23.583	-56.740	-7.630	-23.465	-56.283	-7.667	-0.118	-0.457	0.037	0.474
-21.409	-52.756	-5.336	-21.295	-52.312	-5.237	-0.114	-0.444	-0.099	0.469
-13.351	-62.656	-5.389	-13.176	-62.230	-5.361	-0.175	-0.426	-0.028	0.462
-17.746	-63.944	-7.691	-17.584	-63.521	-7.750	-0.162	-0.423	0.059	0.457
-21.207	-64.958	-11.635	-21.048	-64.532	-11.462	-0.159	-0.426	-0.173	0.487

-23.883	-65.363	-15.586	-23.883	-65.363	-15.586	0.000	0.000	0.000	
-25.270	-69.597	-14.549	-24.303	-69.676	-15.657	-0.967	0.079	1.108	1.473
-22.040	-71.357	-11.564	-21.660	-71.125	-11.521	-0.380	-0.232	-0.043	0.448
-18.751	-73.169	-7.682	-18.560	-72.823	-7.817	-0.191	-0.346	0.135	0.418
-14.760	-75.352	-5.358	-14.505	-75.038	-5.428	-0.255	-0.314	0.070	0.411
-24.692	-83.379	-5.422	-24.554	-83.148	-5.452	-0.138	-0.231	0.030	0.271
-25.975	-78.983	-7.687	-25.847	-78.722	-7.876	-0.128	-0.261	0.189	0.346
-27.022	-75.354	-11.563	-26.820	-75.409	-11.582	-0.202	0.055	0.019	0.210
-27.981	-72.069	-14.902	-27.682	-72.445	-15.713	-0.299	0.376	0.811	0.943
-31.751	-71.717	-15.007	-32.055	-72.000	-15.754	0.304	0.283	0.747	0.855
-33.424	-74.775	-11.631	-33.555	-74.738	-11.618	0.131	-0.037	-0.013	0.137
-35.204	-78.011	-7.739	-35.178	-77.730	-7.897	-0.026	-0.281	0.158	0.324
-37.414	-82.048	-5.509	-37.391	-81.782	-5.480	-0.023	-0.266	-0.029	0.269
-25.397	-86.160	-0.573	-25.283	-85.847	-0.658	-0.114	-0.313	0.085	0.343
-12.973	-77.231	-0.899	-12.811	-76.867	-0.928	-0.162	-0.364	0.029	0.400
-10.947	-61.782	-0.929	-10.865	-61.382	-0.886	-0.082	-0.400	-0.043	0.410
-16.032	-53.552	-0.831	-15.947	-53.161	-0.791	-0.085	-0.391	-0.040	0.402
-25.742	-48.335	-0.671	-25.654	-47.991	-0.604	-0.088	-0.344	-0.067	0.361
-47.238	-37.801	18.699	-47.049	-37.578	18.767	-0.189	-0.223	-0.068	0.301
-43.915	-36.230	12.402	-43.813	-36.041	12.464	-0.102	-0.189	-0.062	0.224
-40.562	-34.643	6.128	-40.555	-34.500	6.174	-0.007	-0.143	-0.046	0.151
-39.706	-41.354	6.115	-39.643	-41.070	6.212	-0.063	-0.284	-0.097	0.307
-43.332	-40.679	12.404	-43.190	-40.404	12.501	-0.142	-0.275	-0.097	0.325
-46.921	-40.007	18.716	-46.718	-39.741	18.796	-0.203	-0.266	-0.080	0.343
-47.945	-42.024	18.747	-47.705	-41.753	18.852	-0.240	-0.271	-0.105	0.377
-45.450	-44.652	12.421	-45.238	-44.362	12.560	-0.212	-0.290	-0.139	0.386
-42.938	-47.293	6.111	-42.745	-46.995	6.282	-0.193	-0.298	-0.171	0.394
-49.046	-50.267	6.141	-48.813	-50.024	6.363	-0.233	-0.243	-0.222	0.404
-49.524	-46.676	12.465	-49.279	-46.408	12.629	-0.245	-0.268	-0.164	0.398
-49.993	-43.140	18.819	-49.739	-42.858	18.927	-0.254	-0.282	-0.108	0.394
-52.343	-42.737	18.841	-52.081	-42.473	18.963	-0.262	-0.264	-0.122	0.391
-54.042	-45.871	12.482	-53.789	-45.601	12.649	-0.253	-0.270	-0.167	0.406
-55.788	-48.978	6.124	-55.518	-48.764	6.361	-0.270	-0.214	-0.237	0.418
-52.135	-40.111	22.708	-51.839	-39.846	22.783	-0.296	-0.265	-0.075	0.405
-57.023	-42.439	12.368	-56.936	-42.258	12.643	-0.087	-0.181	-0.275	0.340
-62.348	-44.966	2.300	-62.083	-44.692	2.543	-0.265	-0.274	-0.243	0.452
-63.356	-36.901	2.290	-62.995	-36.668	2.472	-0.361	-0.233	-0.182	0.467
-57.802	-37.955	12.495	-57.453	-37.717	12.608	-0.349	-0.238	-0.113	0.437
-52.278	-38.996	22.715	-51.915	-38.763	22.748	-0.363	-0.233	-0.033	0.432
-51.659	-38.095	22.655	-51.335	-37.905	22.687	-0.324	-0.190	-0.032	0.377
-55.557	-33.948	12.472	-55.208	-33.800	12.556	-0.349	-0.148	-0.084	0.388
-59.556	-29.687	2.379	-59.138	-29.627	2.472	-0.418	-0.060	-0.093	0.433
-52.158	-26.080	2.453	-51.877	-26.193	2.475	-0.281	0.113	-0.022	0.303
-51.413	-32.035	12.457	-51.142	-31.954	12.516	-0.271	-0.081	-0.059	0.289
-50.693	-37.774	22.583	-50.420	-37.575	22.634	-0.273	-0.199	-0.051	0.342
-49.815	-38.036	22.517	-49.546	-37.851	22.571	-0.269	-0.185	-0.054	0.331
-47.026	-32.926	12.415	-46.815	-32.852	12.466	-0.211	-0.074	-0.051	0.230
-44.080	-27.674	2.421	-44.032	-27.756	2.426	-0.048	0.082	-0.005	0.095

-46.141	3.782	25.082	-46.039	3.954	24.911	-0.102	-0.172	0.171	0.263
-50.373	7.776	27.566	-50.048	7.736	27.381	-0.325	0.040	0.185	0.377
-53.841	11.072	21.772	-53.496	10.994	21.802	-0.345	0.078	-0.030	0.354
-56.496	13.615	8.115	-56.168	13.532	8.252	-0.328	0.083	-0.137	0.364
-61.716	-1.634	8.062	-61.443	-1.587	8.234	-0.273	-0.047	-0.172	0.326
-58.212	-1.359	21.756	-57.864	-1.302	21.815	-0.348	-0.057	-0.059	0.358
-53.419	-0.976	27.495	-53.087	-0.916	27.365	-0.332	-0.060	0.130	0.362
-47.688	-0.515	25.029	-47.648	-0.475	24.855	-0.040	-0.040	0.174	0.183
-45.413	-4.440	25.146	-45.330	-4.567	24.934	-0.083	0.127	0.212	0.261
-48.990	-9.106	27.555	-48.695	-8.967	27.377	-0.295	-0.139	0.178	0.372
-51.838	-12.845	21.716	-51.549	-12.700	21.774	-0.289	-0.145	-0.058	0.328
-54.046	-15.758	8.073	-53.811	-15.669	8.241	-0.235	-0.089	-0.168	0.302
-38.389	-19.464	8.101	-38.212	-19.328	8.239	-0.177	-0.136	-0.138	0.262
-39.120	-15.726	21.677	-38.922	-15.592	21.728	-0.198	-0.134	-0.051	0.245
-39.971	-11.257	27.614	-39.767	-11.107	27.436	-0.204	-0.150	0.178	0.309
-41.082	-5.336	25.285	-40.820	-5.498	25.085	-0.262	0.162	0.200	0.367
-40.273	19.752	8.151	-40.094	19.538	8.243	-0.179	0.214	-0.092	0.294
-40.633	16.000	21.770	-40.433	15.814	21.750	-0.200	0.186	0.020	0.274
-41.060	11.332	27.659	-40.845	11.236	27.422	-0.215	0.096	0.237	0.334
-41.581	5.437	25.172	-41.350	5.591	25.056	-0.231	-0.154	0.116	0.301
-38.761	4.288	25.221	-38.474	4.418	25.111	-0.287	-0.130	0.110	0.334
-35.156	9.027	27.639	-35.008	8.967	27.412	-0.148	0.060	0.227	0.277
-32.365	12.680	21.736	-32.283	12.540	21.703	-0.082	0.140	0.033	0.166
-30.089	15.642	8.141	-30.045	15.471	8.219	-0.044	0.171	-0.078	0.193
-23.813	6.768	8.097	-23.741	6.751	8.193	-0.072	0.017	-0.096	0.121
-27.171	5.511	21.697	-27.124	5.486	21.679	-0.047	0.025	0.018	0.056
-31.393	3.936	27.618	-31.278	3.939	27.411	-0.115	-0.003	0.207	0.236
-37.031	1.820	25.296	-36.685	1.923	25.157	-0.346	-0.103	0.139	0.387
-36.827	-1.151	25.316	-36.462	-1.127	25.170	-0.365	-0.024	0.146	0.394
-30.922	-2.376	27.597	-30.804	-2.306	27.405	-0.118	-0.070	0.192	0.236
-26.559	-3.274	21.662	-26.459	-3.207	21.677	-0.100	-0.067	-0.015	0.121
-23.073	-3.981	8.074	-22.934	-3.934	8.187	-0.139	-0.047	-0.113	0.186
-27.957	-13.621	8.091	-27.834	-13.516	8.209	-0.123	-0.105	-0.118	0.200
-30.661	-11.049	21.652	-30.515	-10.940	21.685	-0.146	-0.109	-0.033	0.185
-33.884	-7.960	27.572	-33.733	-7.841	27.406	-0.151	-0.119	0.166	0.254
-38.219	-3.774	25.313	-37.869	-3.851	25.133	-0.350	0.077	0.180	0.401
-42.122	5.473	25.161	-41.901	5.623	25.046	-0.221	-0.150	0.115	0.290
-42.183	11.380	27.662	-41.952	11.275	27.406	-0.231	0.105	0.256	0.361
-42.214	16.063	21.766	-41.990	15.911	21.764	-0.224	0.152	0.002	0.271
-42.222	19.866	8.153	-42.018	19.644	8.249	-0.204	0.222	-0.096	0.317
-40.872	1.180	20.160	-40.588	1.376	20.122	-0.284	-0.196	0.038	0.348
-44.917	0.179	21.491	-44.903	0.263	21.398	-0.014	-0.084	0.093	0.126
-40.925	-2.164	21.395	-40.584	-2.341	21.273	-0.341	0.177	0.122	0.403
45.123	-41.362	15.137	44.835	-41.117	15.195	0.288	-0.245	-0.058	0.383
42.481	-46.200	13.322	42.205	-45.928	13.339	0.276	-0.272	-0.017	0.388
40.312	-50.184	9.705	40.044	-49.883	9.727	0.268	-0.301	-0.022	0.404
38.843	-52.884	4.792	38.591	-52.539	4.827	0.252	-0.345	-0.035	0.429
31.850	-44.833	4.754	31.801	-44.490	4.732	0.049	-0.343	0.022	0.347

34.677	-43.726	9.669	34.545	-43.421	9.597	0.132	-0.305	0.072	0.340
38.887	-42.084	13.289	38.660	-41.817	13.229	0.227	-0.267	0.060	0.356
44.000	-40.084	15.144	43.717	-39.839	15.161	0.283	-0.245	-0.017	0.375
43.959	-38.382	15.136	43.677	-38.143	15.150	0.282	-0.239	-0.014	0.369
38.764	-36.626	13.273	38.555	-36.413	13.183	0.209	-0.213	0.090	0.312
34.509	-35.183	9.645	34.414	-35.009	9.538	0.095	-0.174	0.107	0.225
31.680	-34.222	4.730	31.666	-34.079	4.692	0.014	-0.143	0.038	0.149
38.323	-26.017	4.723	38.127	-25.955	4.712	0.196	-0.062	0.011	0.206
39.859	-28.557	9.627	39.650	-28.456	9.551	0.209	-0.101	0.076	0.245
42.178	-32.375	13.267	41.922	-32.192	13.208	0.256	-0.183	0.059	0.320
45.023	-37.055	15.141	44.738	-36.820	15.151	0.285	-0.235	-0.010	0.369
46.693	-36.720	15.143	46.403	-36.481	15.193	0.290	-0.239	-0.050	0.379
47.519	-31.306	13.271	47.227	-31.074	13.313	0.292	-0.232	-0.042	0.376
48.199	-26.870	9.652	47.899	-26.670	9.676	0.300	-0.200	-0.024	0.362
48.657	-23.934	4.751	48.345	-23.742	4.785	0.312	-0.192	-0.034	0.368
38.849	-52.874	4.788	38.591	-52.539	4.826	0.258	-0.335	-0.038	0.425
40.314	-50.182	9.704	40.047	-49.882	9.726	0.267	-0.300	-0.022	0.403
42.482	-46.203	13.332	42.205	-45.928	13.337	0.277	-0.275	-0.005	0.391
45.123	-41.361	15.137	44.835	-41.117	15.193	0.288	-0.244	-0.056	0.382
47.511	-36.994	15.159	47.221	-36.754	15.206	0.290	-0.240	-0.047	0.380
50.095	-32.165	13.271	49.852	-31.942	13.352	0.243	-0.223	-0.081	0.340
52.234	-28.235	9.649	52.008	-28.003	9.721	0.226	-0.232	-0.072	0.332
53.658	-25.613	4.756	53.428	-25.378	4.817	0.230	-0.235	-0.061	0.335
60.570	-33.610	4.711	60.468	-33.294	4.839	0.102	-0.316	-0.128	0.356
57.885	-34.656	9.636	57.717	-34.369	9.802	0.168	-0.287	-0.166	0.372
53.735	-36.278	13.281	53.497	-36.018	13.442	0.238	-0.260	-0.161	0.387
48.634	-38.273	15.146	48.347	-38.031	15.230	0.287	-0.242	-0.084	0.384
48.676	-39.976	15.151	48.391	-39.735	15.250	0.285	-0.241	-0.099	0.386
53.872	-41.725	13.286	53.653	-41.510	13.486	0.219	-0.215	-0.200	0.367
58.085	-43.141	9.626	57.973	-42.968	9.851	0.112	-0.173	-0.225	0.305
60.769	-44.039	4.682	60.756	-43.906	4.853	0.013	-0.133	-0.171	0.217
54.348	-52.317	4.729	54.155	-52.273	4.880	0.193	-0.044	-0.151	0.249
52.815	-49.822	9.666	52.585	-49.703	9.848	0.230	-0.119	-0.182	0.317
50.474	-45.993	13.307	50.207	-45.798	13.472	0.267	-0.195	-0.165	0.370
47.613	-41.304	15.156	47.324	-41.065	15.241	0.289	-0.239	-0.085	0.384
45.942	-41.638	15.150	45.651	-41.397	15.216	0.291	-0.241	-0.066	0.383
45.117	-47.087	13.321	44.820	-46.859	13.420	0.297	-0.228	-0.099	0.387
44.440	-51.582	9.721	44.140	-51.336	9.788	0.300	-0.246	-0.067	0.394
43.987	-54.617	4.798	43.679	-54.382	4.880	0.308	-0.235	-0.082	0.395
53.658	-25.613	4.756	53.428	-25.378	4.818	0.230	-0.235	-0.062	0.335
52.234	-28.236	9.650	52.005	-28.003	9.723	0.229	-0.233	-0.073	0.335
50.094	-32.167	13.273	49.851	-31.943	13.350	0.243	-0.224	-0.077	0.339
47.510	-36.995	15.159	47.222	-36.754	15.206	0.288	-0.241	-0.047	0.379
32.226	-49.736	0.360	32.076	-49.376	0.296	0.150	-0.360	0.064	0.395
36.628	-54.099	0.250	36.394	-53.737	0.275	0.234	-0.362	-0.025	0.432
45.220	-56.433	0.575	44.908	-56.168	0.777	0.312	-0.265	-0.202	0.456
54.511	-53.938	0.617	54.255	-53.810	0.918	0.256	-0.128	-0.301	0.415
60.597	-47.619	1.876	60.487	-47.510	0.976	0.110	-0.109	0.900	0.914

62.909	-39.423	1.890	62.789	-39.196	0.960	0.120	-0.227	0.930	0.965
5.587	29.366	-10.592	5.493	29.279	-10.426	0.094	0.087	-0.166	0.210
2.218	29.342	-10.607	2.142	29.278	-10.427	0.076	0.064	-0.180	0.206
2.196	26.453	-0.004	2.140	26.302	0.087	0.056	0.151	-0.091	0.185
-1.148	29.410	-10.592	-1.204	29.277	-10.431	0.056	0.133	-0.161	0.217
5.591	19.805	-12.623	5.493	19.958	-12.530	0.098	-0.153	-0.093	0.204
2.202	23.069	-2.138	2.141	23.119	-2.074	0.061	-0.050	-0.064	0.101
2.224	19.807	-12.629	2.145	19.966	-12.533	0.079	-0.159	-0.096	0.202
-1.143	19.796	-12.633	-1.203	19.967	-12.534	0.060	-0.171	-0.099	0.207
8.047	27.565	-10.584	7.899	27.432	-10.457	0.148	0.133	-0.127	0.236
8.028	25.040	-10.593	7.911	24.919	-10.452	0.117	0.121	-0.141	0.219
3.913	25.031	-0.035	3.789	24.916	0.038	0.124	0.115	-0.073	0.184
8.046	22.516	-10.589	7.900	22.410	-10.454	0.146	0.106	-0.135	0.225
-4.641	27.566	-12.642	-4.462	27.435	-12.550	-0.179	0.131	-0.092	0.240
-0.495	25.031	-2.096	-0.364	24.917	-2.053	-0.131	0.114	-0.043	0.179
-4.649	25.041	-12.641	-4.443	24.922	-12.558	-0.206	0.119	-0.083	0.252
-4.652	22.516	-12.642	-4.451	22.412	-12.556	-0.201	0.104	-0.086	0.242
-9.016	4.966	-2.196	-9.136	5.027	-2.062	0.120	-0.061	-0.134	0.189
-9.124	4.998	9.589	-9.129	5.015	9.657	0.005	-0.017	-0.068	0.070
-0.612	10.467	9.609	-0.649	10.465	9.661	0.037	0.002	-0.052	0.064
-0.580	10.391	-2.178	-0.640	10.421	-2.058	0.060	-0.030	-0.120	0.137
8.558	6.129	-2.165	8.411	6.093	-2.055	0.147	0.036	-0.110	0.187
8.506	6.101	9.619	8.448	6.120	9.664	0.058	-0.019	-0.045	0.076
9.940	-3.257	9.611	9.898	-3.227	9.660	0.042	-0.030	-0.049	0.071
10.116	-3.300	0.773	9.946	-3.238	0.872	0.170	-0.062	-0.099	0.206
0.064	-10.512	0.750	0.006	-10.487	0.866	0.058	-0.025	-0.116	0.132
0.045	-10.533	9.590	0.001	-10.494	9.656	0.044	-0.039	-0.066	0.088
-9.871	-3.263	9.578	-9.893	-3.222	9.654	0.022	-0.041	-0.076	0.089
-9.879	-3.265	0.741	-9.908	-3.225	0.865	0.029	-0.040	-0.124	0.134
10.629	-10.077	3.720	10.617	-10.080	3.799	0.012	0.003	-0.079	0.080
-11.082	-9.532	3.672	-11.103	-9.481	3.788	0.021	-0.051	-0.116	0.128
-14.453	1.885	0.728	-14.468	1.906	0.862	0.015	-0.021	-0.134	0.137
-8.214	12.001	3.697	-8.240	12.006	3.801	0.026	-0.005	-0.104	0.107
3.469	14.147	0.780	3.426	14.193	0.878	0.043	-0.046	-0.098	0.116
12.877	6.926	3.741	12.853	6.959	3.809	0.024	-0.033	-0.068	0.079
1.954	2.156	-16.615	1.868	1.516	-16.645	0.086	0.640	0.030	0.647
-3.722	3.829	-16.691	-3.775	3.824	-16.915	0.053	0.005	0.224	0.230
-3.803	-4.104	-16.583	-3.857	-4.063	-16.907	0.054	-0.041	0.324	0.331
3.769	-3.959	-16.499	3.672	-3.921	-16.887	0.097	-0.038	0.388	0.402
-0.350	0.220	-20.993	-0.350	0.220	-20.993	0.000	0.000	0.000	
-9.358	-8.555	13.108	-9.337	-8.473	12.743	-0.021	-0.082	0.365	0.375
-11.999	3.505	13.085	-11.959	3.518	12.760	-0.040	-0.013	0.325	0.328
-0.924	11.984	13.083	-0.947	11.949	12.782	0.023	0.035	0.301	0.303
11.236	4.915	13.132	11.147	4.916	12.843	0.089	-0.001	0.289	0.302
10.583	-7.026	13.182	10.494	-6.957	12.814	0.089	-0.069	0.368	0.385
0.444	-12.831	13.095	0.411	-12.729	12.733	0.033	-0.102	0.362	0.378
-0.422	-14.702	6.779	-0.463	-14.682	6.860	0.041	-0.020	-0.081	0.093
6.970	-46.785	6.626	6.897	-46.496	6.712	0.073	-0.289	-0.086	0.311

6.976	-36.777	6.637	6.945	-36.544	6.717	0.031	-0.233	-0.080	0.248
6.989	-26.769	6.644	6.971	-26.594	6.722	0.018	-0.175	-0.078	0.193
7.021	-16.762	6.653	6.984	-16.643	6.726	0.037	-0.119	-0.073	0.145
4.471	-17.725	6.640	4.469	-17.597	6.722	0.002	-0.128	-0.082	0.152
4.437	-27.449	6.634	4.453	-27.266	6.717	-0.016	-0.183	-0.083	0.201
4.433	-37.171	6.623	4.440	-36.935	6.714	-0.007	-0.236	-0.091	0.253
4.398	-46.894	6.616	4.416	-46.603	6.710	-0.018	-0.291	-0.094	0.306
-4.028	-46.908	9.553	-3.984	-46.616	9.639	-0.044	-0.292	-0.086	0.308
-4.031	-37.222	9.558	-3.995	-36.984	9.642	-0.036	-0.238	-0.084	0.255
-4.010	-27.537	9.568	-3.971	-27.354	9.646	-0.039	-0.183	-0.078	0.203
-3.977	-17.853	9.576	-3.970	-17.724	9.651	-0.007	-0.129	-0.075	0.150
-8.059	-16.110	3.671	-8.032	-15.990	3.787	-0.027	-0.120	-0.116	0.169
-8.132	-26.311	3.663	-8.056	-26.134	3.783	-0.076	-0.177	-0.120	0.227
-8.160	-36.510	3.653	-8.054	-36.277	3.779	-0.106	-0.233	-0.126	0.285
-8.177	-46.711	3.644	-8.057	-46.420	3.775	-0.120	-0.291	-0.131	0.341
-6.038	-50.193	7.046	-6.054	-50.231	7.152	0.016	0.038	-0.106	0.114
5.707	-50.234	10.304	5.630	-50.246	10.373	0.077	0.012	-0.069	0.104
5.693	-46.561	13.148	5.625	-46.269	12.959	0.068	-0.292	0.189	0.354
5.716	-37.515	13.089	5.648	-37.276	12.893	0.068	-0.239	0.196	0.316
5.624	-28.471	13.108	5.559	-28.284	12.877	0.065	-0.187	0.231	0.305
5.853	-17.503	13.161	5.790	-17.377	12.855	0.063	-0.126	0.306	0.337
-6.136	-16.945	13.062	-6.134	-16.819	12.753	-0.002	-0.126	0.309	0.334
-6.257	-27.349	13.042	-6.257	-27.163	12.792	0.000	-0.186	0.250	0.311
-6.282	-36.167	13.044	-6.283	-35.933	12.816	0.001	-0.234	0.228	0.327
-5.823	-47.920	13.106	-5.828	-47.620	12.889	0.005	-0.300	0.217	0.370
63.036	-85.793	-0.071	62.619	-85.301	0.064	0.417	-0.492	-0.135	0.658
51.607	-86.159	-0.198	51.253	-85.664	-0.053	0.354	-0.495	-0.145	0.625
30.859	-85.678	-0.251	30.623	-85.183	-0.106	0.236	-0.495	-0.145	0.567
26.876	-77.960	-0.266	26.664	-77.507	-0.108	0.212	-0.453	-0.158	0.525
40.063	-79.686	-0.477	39.774	-79.225	-0.297	0.289	-0.461	-0.180	0.573
56.499	-76.298	-0.375	56.120	-75.860	-0.229	0.379	-0.438	-0.146	0.597
61.148	-67.000	-0.491	60.745	-66.614	-0.365	0.403	-0.386	-0.126	0.572
47.157	-70.251	-0.621	46.832	-69.844	-0.453	0.325	-0.407	-0.168	0.547
37.639	-65.853	-0.405	37.366	-65.470	-0.294	0.273	-0.383	-0.111	0.483
23.987	-65.523	-0.148	23.793	-65.141	-0.069	0.194	-0.382	-0.079	0.436
20.026	-53.422	-0.118	19.857	-53.105	-0.143	0.169	-0.317	0.025	0.361
15.259	-46.295	-0.125	15.117	-46.016	-0.220	0.142	-0.279	0.095	0.327
23.669	-45.550	-0.146	23.480	-45.277	-0.238	0.189	-0.273	0.092	0.344
14.909	-35.361	-0.070	14.771	-35.143	-0.238	0.138	-0.218	0.168	0.307
15.775	-25.401	0.045	15.632	-25.237	-0.177	0.143	-0.164	0.222	0.311
25.686	-28.340	-0.046	25.489	-28.161	-0.223	0.197	-0.179	0.177	0.319
33.673	-23.346	0.080	33.431	-23.198	-0.144	0.242	-0.148	0.224	0.362
61.762	-24.495	0.022	61.365	-24.344	-0.085	0.397	-0.151	0.107	0.438
68.143	-35.015	-0.137	67.707	-34.807	-0.156	0.436	-0.208	0.019	0.484
65.335	-54.986	-0.210	64.911	-54.667	-0.130	0.424	-0.319	-0.080	0.536
68.999	-6.566	0.031	68.564	-6.517	0.004	0.435	-0.049	0.027	0.439
66.174	18.433	-0.084	65.760	18.342	-0.104	0.414	0.091	0.020	0.425
52.268	19.012	-0.453	51.930	18.921	-0.522	0.338	0.091	0.069	0.357

38.391	18.763	-0.485	38.129	18.676	-0.606	0.262	0.087	0.121	0.301
25.036	19.088	-0.024	24.851	19.002	-0.222	0.185	0.086	0.198	0.284
27.140	28.547	-0.115	26.945	28.406	-0.254	0.195	0.141	0.139	0.278
34.281	26.883	-0.302	34.045	26.752	-0.385	0.236	0.131	0.083	0.282
46.024	25.947	-0.507	45.722	25.819	-0.532	0.302	0.128	0.025	0.329
45.709	34.489	-0.092	45.411	34.313	-0.207	0.298	0.176	0.115	0.365
29.735	39.403	-0.125	29.528	39.201	-0.211	0.207	0.202	0.086	0.302
17.378	42.247	-0.295	17.240	42.033	-0.390	0.138	0.214	0.095	0.272
7.137	39.376	-0.085	7.055	39.182	-0.284	0.082	0.194	0.199	0.290
10.308	49.429	-0.172	10.211	49.177	-0.211	0.097	0.252	0.039	0.273
22.996	52.391	-0.032	22.828	52.118	-0.094	0.168	0.273	0.062	0.326
43.296	55.639	0.185	43.016	55.345	0.033	0.280	0.294	0.152	0.433
66.488	54.305	0.338	66.079	54.016	0.171	0.409	0.289	0.167	0.528
67.076	38.327	0.020	66.661	38.126	-0.038	0.415	0.201	0.058	0.465
-12.147	40.852	-0.168	-12.122	40.651	-0.373	-0.025	0.201	0.205	0.288
-22.726	17.559	0.069	-22.645	17.491	-0.268	-0.081	0.068	0.337	0.353
-24.026	30.750	-0.059	-23.936	30.608	-0.280	-0.090	0.142	0.221	0.278
-31.205	26.065	0.089	-31.075	25.951	-0.259	-0.130	0.114	0.348	0.388
-42.936	26.727	0.058	-42.740	26.611	-0.313	-0.196	0.116	0.371	0.436
-50.428	30.581	-0.006	-50.190	30.445	-0.274	-0.238	0.136	0.268	0.384
-40.381	46.131	-0.097	-40.197	45.906	-0.157	-0.184	0.225	0.060	0.297
-47.502	54.690	-0.052	-47.277	54.418	-0.020	-0.225	0.272	-0.032	0.354
-75.515	53.906	-0.030	-75.133	53.646	0.147	-0.382	0.260	-0.177	0.495
-75.732	37.626	-0.265	-75.351	37.454	-0.096	-0.381	0.172	-0.169	0.451
-74.518	19.466	-0.343	-74.150	19.397	-0.155	-0.368	0.069	-0.188	0.419
-57.040	25.368	-0.052	-56.767	25.262	-0.261	-0.273	0.106	0.209	0.360
-66.080	12.061	-0.098	-65.760	12.033	-0.167	-0.320	0.028	0.069	0.329
-68.594	-0.997	-0.230	-68.262	-0.954	-0.187	-0.332	-0.043	-0.043	0.338
-76.948	-10.689	-0.496	-76.572	-10.592	-0.272	-0.376	-0.097	-0.224	0.448
-76.811	-29.166	-0.462	-76.440	-28.964	-0.262	-0.371	-0.202	-0.200	0.468
-62.547	-24.764	0.048	-62.251	-24.591	-0.048	-0.296	-0.173	0.096	0.355
-49.860	-21.804	0.199	-49.637	-21.649	0.050	-0.223	-0.155	0.149	0.310
-35.532	-26.506	0.254	-35.388	-26.326	0.010	-0.144	-0.180	0.244	0.336
-22.775	-18.023	0.109	-22.701	-17.894	-0.260	-0.074	-0.129	0.369	0.398
-27.790	-36.968	0.099	-27.690	-36.731	-0.119	-0.100	-0.237	0.218	0.337
-13.661	-51.052	-0.144	-13.643	-50.740	-0.278	-0.018	-0.312	0.134	0.340
-5.162	-60.107	-0.313	-5.195	-59.745	-0.390	0.033	-0.362	0.077	0.371
-6.398	-70.908	-0.432	-6.426	-70.487	-0.397	0.028	-0.421	-0.035	0.423
-7.744	-86.126	-0.301	-7.767	-85.622	-0.254	0.023	-0.504	-0.047	0.507
-27.173	-90.722	-0.114	-27.087	-90.187	-0.028	-0.086	-0.535	-0.086	0.549
-40.864	-88.478	-0.205	-40.703	-87.954	-0.093	-0.161	-0.524	-0.112	0.559
-53.621	-82.065	-0.203	-53.387	-81.573	-0.030	-0.234	-0.492	-0.173	0.571
-62.831	-90.688	-0.229	-62.547	-90.145	-0.027	-0.284	-0.543	-0.202	0.645
-77.157	-85.986	-0.283	-76.793	-85.468	-0.023	-0.364	-0.518	-0.260	0.684
-75.499	-64.413	-0.327	-75.141	-64.017	-0.169	-0.358	-0.396	-0.158	0.557
-71.889	-44.147	-0.268	-71.547	-43.862	-0.108	-0.342	-0.285	-0.160	0.472
-65.737	-56.049	-0.060	-65.432	-55.700	0.058	-0.305	-0.349	-0.118	0.478
-62.112	-65.840	-0.049	-61.827	-65.437	0.070	-0.285	-0.403	-0.119	0.508

-50.394	-58.779	-0.019	-50.174	-58.417	-0.055	-0.220	-0.362	0.036	0.425
-50.149	-72.836	-0.177	-49.933	-72.395	-0.128	-0.216	-0.441	-0.049	0.494
-13.988	-37.895	-16.375	-13.993	-37.666	-16.696	0.005	-0.229	0.321	0.395
-14.384	-16.497	-15.960	-14.380	-16.386	-16.723	-0.004	-0.111	0.763	0.771
-13.563	16.180	-16.317	-13.559	16.109	-16.749	-0.004	0.071	0.432	0.438
-13.395	29.387	-16.406	-13.387	29.241	-16.756	-0.008	0.146	0.350	0.379
14.666	31.645	-16.136	14.517	31.484	-16.737	0.149	0.161	0.601	0.640
15.534	23.940	-16.587	15.377	23.821	-16.708	0.157	0.119	0.121	0.232
15.797	12.248	-16.450	15.636	12.194	-16.720	0.161	0.054	0.270	0.319
59.982	4.331	-15.991	59.575	4.312	-16.749	0.407	0.019	0.758	0.861
58.423	-9.940	-16.582	58.021	-9.879	-16.754	0.402	-0.061	0.172	0.442
48.930	-15.233	-16.632	48.580	-15.140	-16.740	0.350	-0.093	0.108	0.378
36.521	-9.637	-16.460	36.241	-9.572	-16.731	0.280	-0.065	0.271	0.395
30.750	-17.661	-16.411	30.501	-17.551	-16.719	0.249	-0.110	0.308	0.411
13.292	-15.141	-16.361	13.141	-15.042	-16.704	0.151	-0.099	0.343	0.388
19.563	2.832	-4.814	19.398	2.836	-4.546	0.165	-0.004	-0.268	0.315
28.950	7.239	-5.654	28.732	7.217	-4.683	0.218	0.022	-0.971	0.996
34.472	2.980	-4.426	34.225	2.980	-4.672	0.247	0.000	0.246	0.348
41.227	7.361	-5.160	40.943	7.335	-4.717	0.284	0.026	-0.443	0.527
46.453	2.175	-4.390	46.139	2.178	-4.573	0.314	-0.003	0.183	0.364
52.052	8.393	-5.018	51.706	8.359	-4.565	0.346	0.034	-0.453	0.570
50.871	-3.206	0.231	50.539	-3.171	0.077	0.332	-0.035	0.154	0.368
40.348	-3.001	0.212	40.074	-2.967	-0.003	0.274	-0.034	0.215	0.350
28.655	-2.809	0.195	28.447	-2.774	-0.087	0.208	-0.035	0.282	0.352
16.967	-2.002	0.180	16.824	-1.968	-0.116	0.143	-0.034	0.296	0.331
18.583	-9.331	2.042	18.431	-9.257	1.718	0.152	-0.074	0.324	0.365
24.742	-6.497	1.954	24.556	-6.440	1.669	0.186	-0.057	0.285	0.345
25.854	-14.805	2.232	25.661	-14.701	1.864	0.193	-0.104	0.368	0.429
18.830	-12.169	-4.162	18.665	-12.185	-4.050	0.165	0.016	-0.112	0.199
25.720	-16.347	0.231	25.524	-16.406	0.308	0.196	0.059	-0.077	0.219
33.037	-3.756	-4.191	32.795	-3.776	-4.106	0.242	0.020	-0.085	0.257
40.060	-3.712	-3.423	39.779	-3.692	-3.354	0.281	-0.020	-0.069	0.290
52.685	-3.686	-4.674	52.332	-3.657	-4.617	0.353	-0.029	-0.057	0.359
54.962	0.205	-8.939	55.001	0.082	-8.863	-0.039	0.123	-0.076	0.150
56.362	7.914	-9.675	56.356	7.881	-9.600	0.006	0.033	-0.075	0.082
59.508	12.439	-0.730	59.130	12.437	-0.816	0.378	0.002	0.086	0.388
49.294	13.365	-1.662	48.971	13.385	-1.758	0.323	-0.020	0.096	0.338
39.456	12.650	-1.565	39.188	12.681	-1.594	0.268	-0.031	0.029	0.272

*Appendix D      Aluminium Castings -  
Histograms (3D-Tol  
Data)*

Histogram for 3DP Aluminium Casting

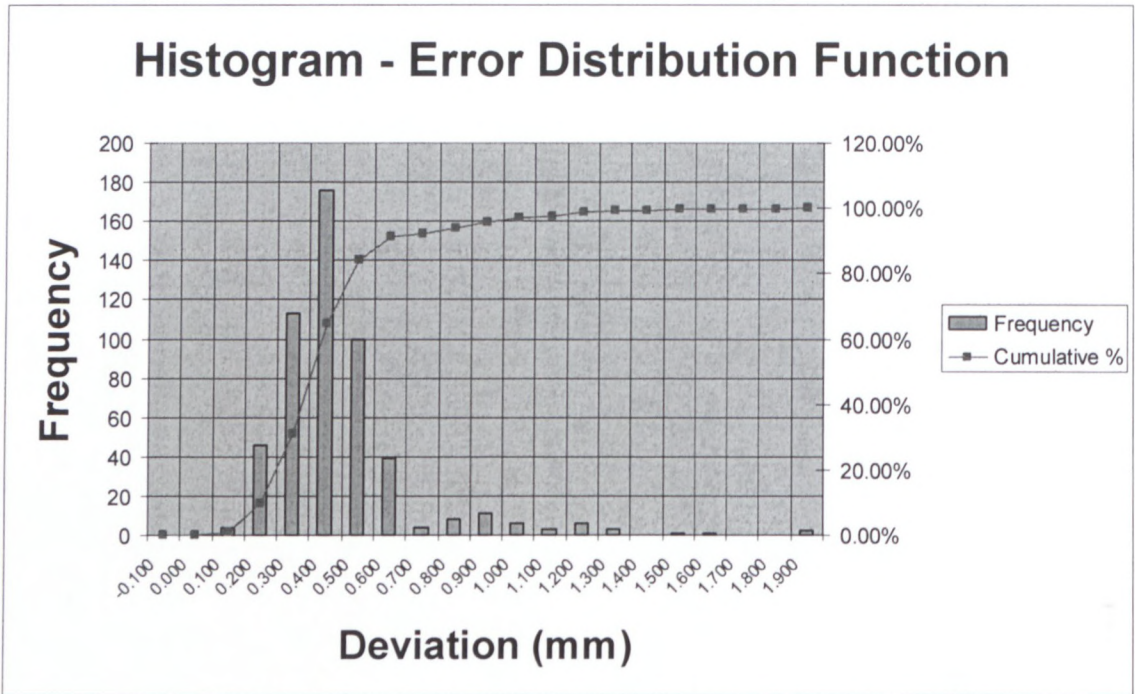

Histogram for SLS Aluminium Casting

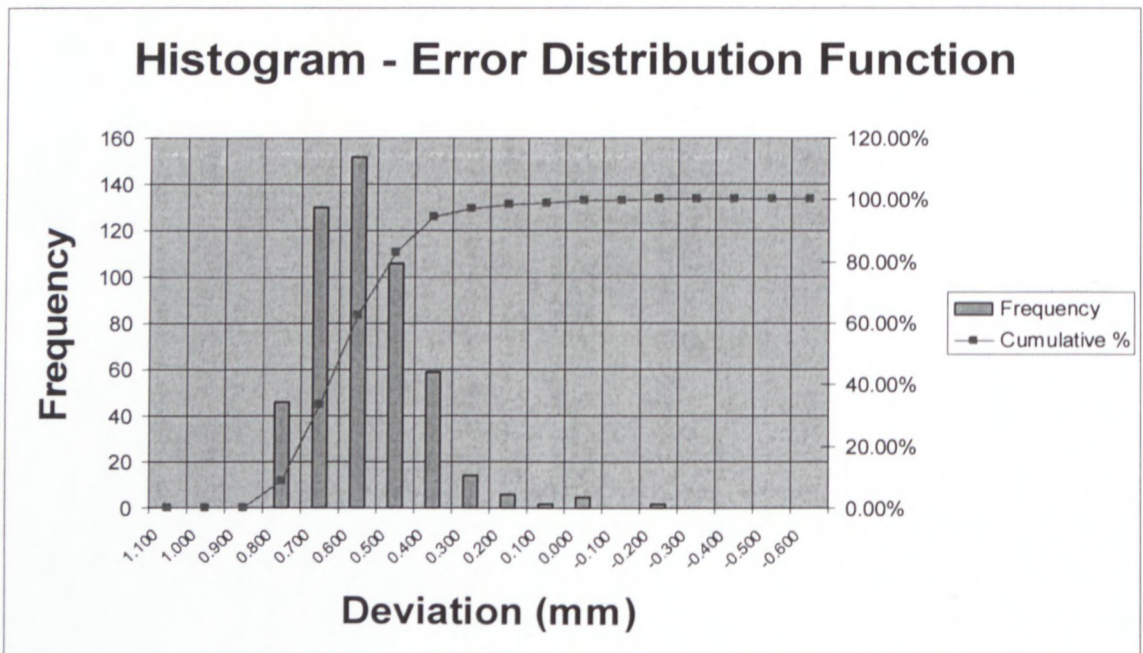

### Histogram for ThermoJet Aluminium Casting

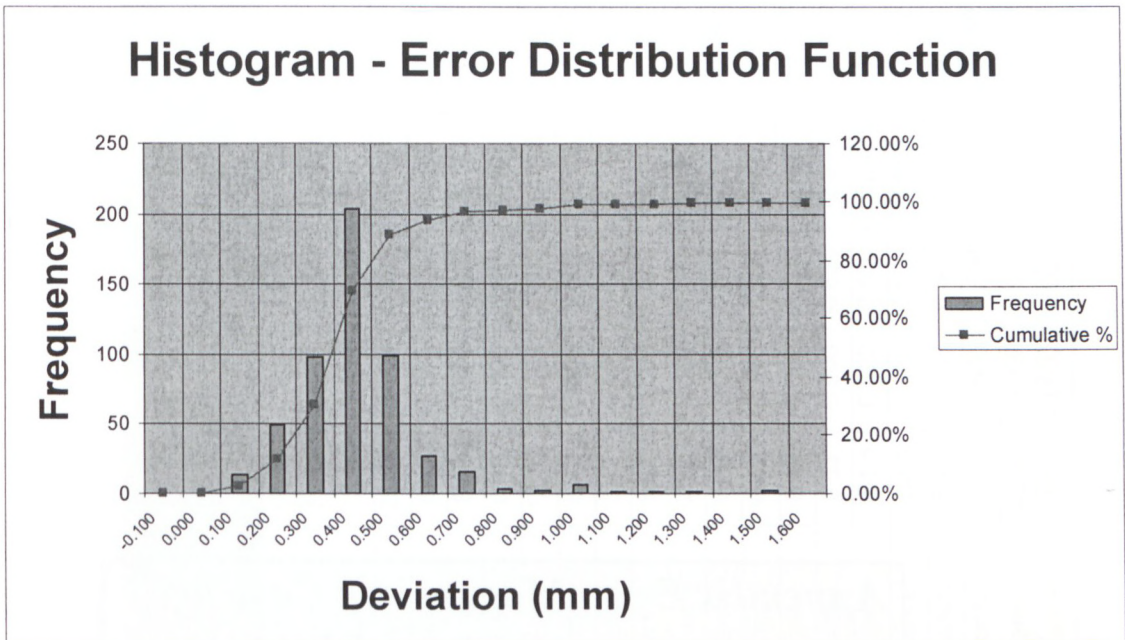

*Appendix E      Magnesium Castings -  
Features CMM Data*

A basic tolerance of  $\pm 0.5$  mm is used for all feature measurements on all castings.

### Feature Tolerances – 3DP Magnesium Casting

Feature Tolerances - 3DP Casting Pattern 10										
Tolerance No.	Feature	Tol.ElemName	Compared to	Type of Tolerance	Spec.	Lower Tol.	Upper Tol.	Actual	Tol. Deviation	Result
A1	Square Base	Line	Point	Distance	58.92	-0.500	0.500	60.854	1.934	High
A2	Pattern	Line	Point	Distance	71.54	-0.500	0.500	71.468	-0.072	Good
A3	Pattern	Line	Point	Distance	2.1	-0.500	0.500	2.371	0.271	Good
A4	Rectangular Protrusion	Line	Point	Distance	25.25	-0.500	0.500	26.024	0.774	High
A5	Rectangular Protrusion	Line	Point	Distance	8.42	-0.500	0.500	8.842	0.422	Good
A6	Rectangular Protrusion	Line	Point	Distance	8.42	-0.500	0.500	8.183	-0.237	Good
A7	Pattern	Line	Point	Distance	8.42	-0.500	0.500	8.515	0.095	Good
A8	Wedge X	Line	Point	Distance	12.63	-0.500	0.500	12.526	-0.104	Good
A9	Cube 1	Line	Point	Distance	8.42	-0.500	0.500	7.938	-0.482	Good
A10	Cube 1	Line	Point	Distance	8.42	-0.500	0.500	8.361	-0.059	Good
A11	Cube 1	Line	Point	Distance	8.42	-0.500	0.500	8.393	-0.027	Good
A12	Rectangular Hole	Line	Point	Distance	25.2	-0.500	0.500	25.010	-0.190	Good
A13	Rectangular Hole	Line	Point	Distance	8.42	-0.500	0.500	8.516	0.096	Good
A14	Cube 2	Line	Point	Distance	8.42	-0.500	0.500	8.477	0.057	Good
A15	Cube 2	Line	Point	Distance	8.42	-0.500	0.500	8.013	-0.407	Good
A16	Pattern	Line	Point	Distance	2.53	-0.500	0.500	2.097	-0.433	Good
B1	Square Base	Line	Point	Distance	151.5	-0.500	0.500	151.426	-0.074	Good
B2	Cube 1	Line	Point	Distance	8.42	-0.500	0.500	8.609	0.189	Good
C1	Rectangular Protrusion	Line	Point	Distance	8.42	-0.500	0.500	8.619	0.199	Good
C2	Pattern	Line	Point	Distance	1.68	-0.500	0.500	1.738	0.058	Good
C3	Rectangular Protrusion	Line	Point	Distance	25.25	-0.500	0.500	25.039	-0.211	Good
C4	Square Base	Line	Point	Distance	151.5	-0.500	0.500	151.426	-0.074	Good

C5	Wedge X	Line	Point	Distance	25.25	-0.500	0.500	24.771	-0.479	Good
C6	Cube 1	Line	Point	Distance	8.42	-0.500	0.500	8.311	-0.109	Good
CC3	Cube 1	Line	Point	Distance	8.42	-0.500	0.500	8.393	-0.027	Good
CC4	Cube 1	Line	Point	Distance	8.42	-0.500	0.500	8.361	-0.059	Good
CC5	Cylinder Depth	Line	Point	Distance	16.83	-0.500	0.500	16.707	-0.123	Good
D1	Square Base Depth	Line	Point	Distance	29.46	-0.500	0.500	29.491	0.031	Good
D2	Cube 3	Line	Point	Distance	4.21	-0.500	0.500	4.205	-0.005	Good
D3	Cube 3	Line	Point	Distance	8.42	-0.500	0.500	8.398	-0.022	Good
D4	Cube 2	Line	Point	Distance	8.42	-0.500	0.500	8.288	-0.132	Good
E1	Square Base	Line	Point	Distance	151.5	-0.500	0.500	151.759	0.259	Good
E2	Wedge Y	Line	Point	Distance	25.25	-0.500	0.500	25.519	0.269	Good
E3	Wedge Y	Line	Point	Distance	12.63	-0.500	0.500	13.046	0.416	Good
E4	Wedge Y	Line	Point	Distance	6.73	-0.500	0.500	6.797	0.067	Good
E5	Cube 4	Line	Point	Distance	8.42	-0.500	0.500	8.460	0.040	Good
E6	Rectangular Hole	Line	Point	Distance	8.42	-0.500	0.500	8.711	0.291	Good
E7	Rectangular Hole	Line	Point	Distance	25.25	-0.500	0.500	25.585	0.335	Good
E8	Cube 3	Line	Point	Distance	8.42	-0.500	0.500	8.201	-0.219	Good
E9	Cube 3	Line	Point	Distance	8.42	-0.500	0.500	7.897	-0.523	Low
E10	Cylinder Inner Diameter	Line	Point	Distance	21.04	-0.500	0.500	20.897	-0.143	Good
E11	Cylinder Outer Diameter	Line	Point	Distance	29.46	-0.500	0.500	29.493	0.033	Good
E12	Square Base	Line	Point	Distance	151.5	-0.500	0.500	151.040	-0.460	Good
EE1	Triangular Hole	Line	Point	Distance	5.89	-0.500	0.500	5.813	-0.077	Good
EE2	Thin Walls	Line	Point	Distance	4.21	-0.500	0.500	4.405	0.195	Good
EE3	Thin Walls	Line	Point	Distance	2.53	-0.500	0.500	2.749	0.219	Good
AA2	Wedge X-direction	Line	Line	Angularity	75	-0.500	0.500	74.882	-0.118	Good
AA3	Wedge X-direction	Line	Line	Angularity	75	-0.500	0.500	75.880	0.880	High
BB2	Wedge Y-direction	Line	Line	Angularity	60	-0.500	0.500	60.245	0.245	Good
BB3	Wedge Y-direction	Line	Line	Angularity	75	-0.500	0.500	74.094	-0.906	Low
CC1	Pyramid	Line	Line	Angularity	106.7	-0.500	0.500	106.397	-0.303	Good



T24	Cone	Cone Bottom Circle	Cone	Circular runout	-0.500	0.500	0.372	0.372	Good
T26	Cone	Cone Bottom Circle	Theoretical Cone Axis	Circular runout	-0.500	0.500	0.851	0.851	High
T29	Cone	plane_2	Cone	Axial runout	-0.500	0.500	5.383	5.383	High
T31	Cone	Cone	plane_2	Symmetry tol. axis element	-0.500	0.500	0.069	0.069	Good
T32	Cone	Cone Bottom Circle	Cone	Symmetry tol. point element	-0.500	0.500	0.191	0.191	Good
T33	Cone	Cone	plane_2	Angularity	-0.500	0.500	0.018	0.018	Good
T34	Cone	Cone	Theoretical Cone Axis	Coaxiality	-0.500	0.500	0.763	0.763	High
T36	Cone	Cone	Actual Cone Axis	Coaxiality	-0.500	0.500	0.275	0.275	Good
T37	Cone	Cone_Bottom_Circle	Actual Cone Axis	Circular runout	-0.500	0.500	0.274	0.274	Good
T38	Sphere	Sphere Bottom Circle	Sphere Axis	Circular runout	-0.500	0.500	0.530	0.530	High
T39	Sphere	Sphere Bottom Circle	Actual Sphere Axis	Circular runout	-0.500	0.500	0.122	0.122	Good
T41	Sphere	plane_2	Actual Sphere Axis	Axial runout	-0.500	0.500	4.399	4.399	High
T42	Sphere	plane_2	Sphere	Symmetry tol. plane element	-0.500	0.500	2.745	2.745	High
T43	Sphere	Theoretical Sphere Axis	Sphere	Symmetry tol. axis element	-0.500	0.500	0.385	0.385	Good
T47	Sphere	Sphere Bottom Circle	Sphere	Symmetry tol. point element	-0.500	0.500	0.042	0.042	Good
T51	Sphere	Actual Sphere Axis	Theoretical Sphere Axis	Coaxiality	-0.500	0.500	0.534	0.534	High
T52	Sphere	Sphere	Sphere	Concentricity	-0.500	0.500	0.143	0.143	Good

T54	Dome	Dome Bottom Circle	Bottom Circle Actual Dome axis	Circular runout	-0.500	0.500	0.242	0.242	0.242	Good
T56	Dome	Dome Upper Circle	Actual Dome axis	Circular runout	-0.500	0.500	0.088	0.088	0.088	Good
T58	Dome	plane_2	Actual Dome axis	Axial runout	-0.500	0.500	2.017	2.017	2.017	High
T65	Dome	Dome Bottom Circle	Dome Upper Circle	Symmetry tol. point element	-0.500	0.500	0.041	0.041	0.041	Good
T67	Dome	plane_2	Actual Dome axis	Perpendicular arity	-0.500	0.500	0.403	0.403	0.403	Good
T69	Dome	Dome Upper Circle	Dome Bottom Circle	Concentricity	-0.500	0.500	0.167	0.167	0.167	Good
T70	Sinkhole	Sinkhole Upper Circle	Theoretical Sinkhole axis	Circular runout	-0.500	0.500	0.241	0.241	0.241	Good
T71	Sinkhole	Sinkhole Upper Circle	Actual Sinkhole Axis	Circular runout	-0.500	0.500	0.152	0.152	0.152	Good
T72	Sinkhole	Sinkhole Bottom Circle	Theoretical Sinkhole axis	Circular runout	-0.500	0.500	0.390	0.390	0.390	Good
T73	Sinkhole	Sinkhole Bottom Circle	Actual Sinkhole Axis	Circular runout	-0.500	0.500	0.105	0.105	0.105	Good
T79	Sinkhole	Theoretical Sinkhole Axis	plane_2	Symmetry tol. axis element	-0.500	0.500	0.138	0.138	0.138	Good
T82	Sinkhole	Sinkhole Bottom Circle	Sinkhole Bottom Circle	Symmetry tol. point element	-0.500	0.500	0.303	0.303	0.303	Good
T84	Sinkhole	plane_2	Actual Sinkhole Axis	Perpendicular arity	-0.500	0.500	0.988	0.988	0.988	High
T85	Sinkhole	Actual Sinkhole Axis	Theoretical Sinkhole axis	Coaxiality	-0.500	0.500	0.274	0.274	0.274	Good
T86	Sinkhole	Sinkhole Bottom Circle	Sinkhole Lower Circle	Concentricity	-0.500	0.500	0.311	0.311	0.311	Good

## Feature Tolerances – SLS Magnesium Casting

Feature Tolerances - SLS Casting Pattern 6										
Tolerance No.	Feature	Tol.ElemName	Compared to	Type of Tolerance	Spec.	Lower Tol.	Upper Tol.	Actual	Tol. Deviation	Result
A1	Square Base	Line	Point	Distance	58.92	-0.500	0.500	60.973	2.053	High
A2	Pattern	Line	Point	Distance	71.54	-0.500	0.500	71.916	0.376	Good
A3	Pattern	Line	Point	Distance	2.1	-0.500	0.500	2.105	0.005	Good
A4	Rectangular Protrusion	Line	Point	Distance	25.25	-0.500	0.500	25.331	0.081	Good
A5	Rectangular Protrusion	Line	Point	Distance	8.42	-0.500	0.500	8.443	0.023	Good
A6	Rectangular Protrusion	Line	Point	Distance	8.42	-0.500	0.500	8.500	0.080	Good
A7	Pattern	Line	Point	Distance	8.42	-0.500	0.500	8.454	0.034	Good
A8	Wedge X	Line	Point	Distance	12.63	-0.500	0.500	12.649	0.019	Good
A9	Cube 1	Line	Point	Distance	8.42	-0.500	0.500	8.395	-0.025	Good
A10	Cube 1	Line	Point	Distance	8.42	-0.500	0.500	8.500	0.080	Good
A11	Cube 1	Line	Point	Distance	8.42	-0.500	0.500	8.457	0.037	Good
A12	Rectangular Hole	Line	Point	Distance	25.2	-0.500	0.500	25.315	0.115	Good
A13	Rectangular Hole	Line	Point	Distance	8.42	-0.500	0.500	8.444	0.024	Good
A14	Cube 2	Line	Point	Distance	8.42	-0.500	0.500	8.342	-0.078	Good
A15	Cube 2	Line	Point	Distance	8.42	-0.500	0.500	8.518	0.098	Good
A16	Pattern	Line	Point	Distance	2.53	-0.500	0.500	2.483	-0.047	Good
B1	Square Base	Line	Point	Distance	151.5	-0.500	0.500	151.959	0.459	Good
B2	Cube 1	Line	Point	Distance	8.42	-0.500	0.500	8.337	-0.083	Good
C1	Rectangular Protrusion	Line	Point	Distance	8.42	-0.500	0.500	8.299	-0.121	Good
C2	Pattern	Line	Point	Distance	1.68	-0.500	0.500	1.479	-0.201	Good
C3	Rectangular Protrusion	Line	Point	Distance	25.25	-0.500	0.500	25.300	0.050	Good
C4	Square Base	Line	Point	Distance	151.5	-0.500	0.500	151.959	0.459	Good
C5	Wedge X	Line	Point	Distance	25.25	-0.500	0.500	25.236	-0.014	Good

C6	Cube 1	Line	Point	Distance	8.42	-0.500	0.500	8.502	0.082	Good
CC3	Cube 1	Line	Point	Distance	8.42	-0.500	0.500	8.457	0.037	Good
CC4	Cube 1	Line	Point	Distance	8.42	-0.500	0.500	8.500	0.080	Good
CC5	Cylinder Depth	Line	Point	Distance	16.83	-0.500	0.500	17.162	0.332	Good
D1	Square Base Depth	Line	Point	Distance	29.46	-0.500	0.500	31.462	2.002	High
D2	Cube 3	Line	Point	Distance	4.21	-0.500	0.500	4.016	-0.194	Good
D3	Cube 3	Line	Point	Distance	8.42	-0.500	0.500	8.406	-0.014	Good
D4	Cube 2	Line	Point	Distance	8.42	-0.500	0.500	8.321	-0.099	Good
E1	Square Base	Line	Point	Distance	151.5	-0.500	0.500	151.723	0.223	Good
E2	Wedge Y	Line	Point	Distance	25.25	-0.500	0.500	25.215	-0.035	Good
E3	Wedge Y	Line	Point	Distance	12.63	-0.500	0.500	12.514	-0.116	Good
E4	Wedge Y	Line	Point	Distance	6.73	-0.500	0.500	6.658	-0.072	Good
E5	Cube 4	Line	Point	Distance	8.42	-0.500	0.500	8.430	0.010	Good
E6	Rectangular Hole	Line	Point	Distance	8.42	-0.500	0.500	8.427	0.007	Good
E7	Rectangular Hole	Line	Point	Distance	25.25	-0.500	0.500	25.314	0.064	Good
E8	Cube 3	Line	Point	Distance	8.42	-0.500	0.500	8.445	0.025	Good
E9	Cube 3	Line	Point	Distance	8.42	-0.500	0.500	8.593	0.173	Good
E10	Cylinder Inner Diameter	Line	Point	Distance	21.04	-0.500	0.500	20.889	-0.151	Good
E11	Cylinder Outer Diameter	Line	Point	Distance	29.46	-0.500	0.500	29.420	-0.040	Good
E12	Square Base	Line	Point	Distance	151.5	-0.500	0.500	151.816	0.316	Good
EE1	Triangular Hole	Line	Point	Distance	5.89	-0.500	0.500	6.241	0.351	Good
EE2	Thin Walls	Line	Point	Distance	4.21	-0.500	0.500	4.228	0.018	Good
EE3	Thin Walls	Line	Point	Distance	2.53	-0.500	0.500	2.600	0.070	Good
AA2	Wedge X-direction	Line	Line	Angularity	75	-0.500	0.500	75.246	0.246	Good
AA3	Wedge X-direction	Line	Line	Angularity	75	-0.500	0.500	75.134	0.134	Good
BB2	Wedge Y-direction	Line	Line	Angularity	60	-0.500	0.500	60.142	0.142	Good
BB3	Wedge Y-direction	Line	Line	Angularity	75	-0.500	0.500	74.769	-0.231	Good
CC1	Pyramid	Line	Line	Angularity	106.7	-0.500	0.500	106.591	-0.109	Good
CC2	Pyramid	Line	Line	Angularity	106.7	-0.500	0.500	106.612	-0.088	Good

DD1	Pyramid	Line	Line	Line	Angularity	111.8	-0.500	0.500	112.204	0.404	Good
DD2	Pyramid	Line	Line	Line	Angularity	111.8	-0.500	0.500	110.489	-1.311	Low
T1	Triangular Hole	Line	Line	Line	Perpendicularity		-0.500	0.500	0.003	0.003	Good
T2	Cylinder Hole/ Hollow Cylinder	Outer Circle	Inner Circle	Inner Circle	Circularity		-0.500	0.500	0.052	0.052	Good
T3	Cylinder Hole/ Hollow Cylinder	Outer Circle	Inner Circle	Inner Circle	Concentricity		-0.500	0.500	0.047	0.047	Good
T4	Cylinder Hole/ Hollow Cylinder	Outer Circle	Inner Circle	Inner Circle	Circularity		-0.500	0.500	0.048	0.048	Good
T5	Square Base	Plane			Flatness		-0.500	0.500	0.564	0.564	High
T6	Square Base	Left_Side		Bottom Side	Perpendicularity		-0.500	0.500	0.053	0.053	Good
T7	Square Base	Top_Side		Right Side	Perpendicularity		-0.500	0.500	0.036	0.036	Good
T8	Square Base	Left_Side		Right Side	Parallelism		-0.500	0.500	0.016	0.016	Good
T9	Square Base	Top_Side		Bottom Side	Parallelism		-0.500	0.500	0.105	0.105	Good
T10	Thin Walls	Line	Line	Line	Parallelism		-0.500	0.500	0.285	0.285	Good
T11	Thin Walls	Line	Line	Line	Parallelism		-0.500	0.500	0.079	0.079	Good
T12	Thin Walls	Line	Line	Line	Thickness		-0.500	0.500	0.219	0.219	Good
T13	Thin Walls	Line	Line	Line	Thickness		-0.500	0.500	0.221	0.221	Good
T14	Cube's 2,3,1	Cube231			Straightness		-0.500	0.500	0.018	0.018	Good
T15	Cube's 1,4, RecProtr	Cube14Rec			Straightness		-0.500	0.500	0.074	0.074	Good
T16	Rectangular Protrusion Outer	RecP2		RecP1	Perpendicularity		-0.500	0.500	0.131	0.131	Good
T17	Rectangular Protrusion Inner	RecP4		RecP3	Perpendicularity		-0.500	0.500	0.918	0.918	High
T18	Rectangular Hole Outer	Rech4		Rech3	Perpendicularity		-0.500	0.500	0.419	0.419	Good
T19	Rectangular Hole Inner	Rech1		Rech2	Perpendicularity		-0.500	0.500	0.191	0.191	Good
T23	Cone	Actual Cone Axis		Cone	Symmetry tol. axis element		-0.500	0.500	0.064	0.064	Good
T24	Cone	Cone Bottom Circle		Cone	Circular runout		-0.500	0.500	0.125	0.125	Good
T26	Cone	Cone Bottom Circle		Theoretical Cone Axis	Circular runout		-0.500	0.500	0.337	0.337	Good

T29	Cone	plane_2	Cone	Axial runout		-0.500	0.500	0.316	0.316	Good
T31	Cone	Cone	plane_2	Symmetry tol. axis element		-0.500	0.500	0.457	0.457	Good
T32	Cone	Cone Bottom Circle	Cone	Symmetry tol. point element		-0.500	0.500	0.008	0.008	Good
T33	Cone	Cone	plane_2	Angularity		-0.500	0.500	0.052	0.052	Good
T34	Cone	Cone	Theoretical Cone Axis	Coaxiality		-0.500	0.500	0.254	0.254	Good
T36	Cone	Cone	Actual Cone Axis	Coaxiality		-0.500	0.500	0.141	0.141	Good
T37	Cone	Cone Bottom Circle	Actual Cone Axis	Circular runout		-0.500	0.500	0.071	0.071	Good
T38	Sphere	Sphere Bottom Circle	Sphere Axis	Circular runout		-0.500	0.500	0.396	0.396	Good
T39	Sphere	Sphere Bottom Circle	Actual Sphere Axis	Circular runout		-0.500	0.500	0.071	0.071	Good
T41	Sphere	plane_2	Actual Sphere Axis	Axial runout		-0.500	0.500	2.156	2.156	High
T42	Sphere	plane_2	Sphere	Symmetry tol. plane element		-0.500	0.500	4.220	4.220	High
T43	Sphere	Theoretical Sphere Axis	Sphere	Symmetry tol. axis element		-0.500	0.500	0.286	0.286	Good
T47	Sphere	Sphere Bottom Circle	Sphere	Symmetry tol. point element		-0.500	0.500	0.080	0.080	Good
T51	Sphere	Actual Sphere Axis	Theoretical Sphere Axis	Coaxiality		-0.500	0.500	0.405	0.405	Good
T52	Sphere	Sphere	Sphere Bottom Circle	Concentricity		-0.500	0.500	0.081	0.081	Good
T54	Dome	Dome Bottom Circle	Actual Dome axis	Circular runout		-0.500	0.500	0.062	0.062	Good
T56	Dome	Dome Upper Circle	Actual Dome axis	Circular runout		-0.500	0.500	0.051	0.051	Good

T58	Dome	plane_2	Actual Dome axis	Axial runout	-0.500	0.500	0.614	0.614	High
		Dome Bottom Circle	Dome Upper Circle	Symmetry tol. point element	-0.500	0.500	0.023	0.023	Good
T65	Dome	plane_2	Actual Dome axis	Perpendicularity	-0.500	0.500	0.214	0.214	Good
T67	Dome	Dome Upper Circle	Dome Bottom Circle	Concentricity	-0.500	0.500	0.110	0.110	Good
T69	Dome								Good
T70	Sinkhole	Sinkhole Upper Circle	Theoretical Sinkhole axis	Circular runout	-0.500	0.500	0.300	0.300	Good
		Sinkhole Upper Circle	Actual Sinkhole Axis	Circular runout	-0.500	0.500	0.057	0.057	Good
T71	Sinkhole	Sinkhole Bottom Circle	Theoretical Sinkhole axis	Circular runout	-0.500	0.500	0.471	0.471	Good
T72	Sinkhole	Sinkhole Bottom Circle	Actual Sinkhole Axis	Circular runout	-0.500	0.500	0.209	0.209	Good
T73	Sinkhole								Good
T79	Sinkhole	Theoretical Sinkhole Axis	plane_2	Symmetry tol. axis element	-0.500	0.500	0.368	0.368	Good
		Sinkhole Bottom Circle	Sinkhole Bottom Circle	Symmetry tol. point element	-0.500	0.500	0.002	0.002	Good
T82	Sinkhole	plane_2	Actual Sinkhole Axis	Perpendicularity	-0.500	0.500	0.399	0.399	Good
T84	Sinkhole								Good
		Actual Sinkhole Axis	Theoretical Sinkhole axis	Coaxiality	-0.500	0.500	0.244	0.244	Good
T85	Sinkhole								Good
		Sinkhole Bottom Circle	Sinkhole Lower Circle	Concentricity	-0.500	0.500	0.144	0.144	Good
T86	Sinkhole								Good

## Feature Tolerances – ThermoJet Magnesium Casting

Feature Tolerances - ThermoJet Casting Pattern 4										
Tolerance No.	Feature	Tol.ElemName	Compared to	Type of Tolerance	Spec.	Lower Tol.	Upper Tol.	Actual	Tol. Deviation	Result
A1	Square Base	Line	Point	Distance	58.92	-0.500	0.500	60.308	1.388	High
A2	Pattern	Line	Point	Distance	71.54	-0.500	0.500	71.139	-0.401	Good
A3	Pattern	Line	Point	Distance	2.1	-0.500	0.500	2.090	-0.010	Good
A4	Rectangular Protrosion	Line	Point	Distance	25.25	-0.500	0.500	24.963	-0.287	Good
A5	Rectangular Protrosion	Line	Point	Distance	8.42	-0.500	0.500	8.242	-0.178	Good
A6	Rectangular Protrosion	Line	Point	Distance	8.42	-0.500	0.500	8.245	-0.175	Good
A7	Pattern	Line	Point	Distance	8.42	-0.500	0.500	8.311	-0.109	Good
A8	Wedge X	Line	Point	Distance	12.63	-0.500	0.500	12.504	-0.126	Good
A9	Cube 1	Line	Point	Distance	8.42	-0.500	0.500	8.302	-0.118	Good
A10	Cube 1	Line	Point	Distance	8.42	-0.500	0.500	8.332	-0.088	Good
A11	Cube 1	Line	Point	Distance	8.42	-0.500	0.500	8.319	-0.101	Good
A12	Rectangular Hole	Line	Point	Distance	25.2	-0.500	0.500	25.055	-0.145	Good
A13	Rectangular Hole	Line	Point	Distance	8.42	-0.500	0.500	8.311	-0.109	Good
A14	Cube 2	Line	Point	Distance	8.42	-0.500	0.500	7.956	-0.464	Good
A15	Cube 2	Line	Point	Distance	8.42	-0.500	0.500	8.316	-0.104	Good
A16	Pattern	Line	Point	Distance	2.53	-0.500	0.500	2.486	-0.044	Good
B1	Square Base	Line	Point	Distance	151.5	-0.500	0.500	150.605	-0.895	Low
B2	Cube 1	Line	Point	Distance	8.42	-0.500	0.500	8.671	0.251	Good
C1	Rectangular Protrosion	Line	Point	Distance	8.42	-0.500	0.500	8.399	-0.021	Good
C2	Pattern	Line	Point	Distance	1.68	-0.500	0.500	1.884	0.204	Good
C3	Rectangular Protrosion	Line	Point	Distance	25.25	-0.500	0.500	25.217	-0.033	Good
C4	Square Base	Line	Point	Distance	151.5	-0.500	0.500	150.605	-0.895	Low
C5	Wedge X	Line	Point	Distance	25.25	-0.500	0.500	25.025	-0.225	Good

G6	Cube 1	Line	Point	Distance	8.42	-0.500	0.500	8.330	-0.090	Good
CC3	Cube 1	Line	Point	Distance	8.42	-0.500	0.500	8.319	-0.101	Good
CC4	Cube 1	Line	Point	Distance	8.42	-0.500	0.500	8.332	-0.088	Good
CC5	Cylinder Depth	Line	Point	Distance	16.83	-0.500	0.500	16.279	-0.551	Low
D1	Square Base Depth	Line	Point	Distance	29.46	-0.500	0.500	29.170	-0.290	Good
D2	Cube 3	Line	Point	Distance	4.21	-0.500	0.500	4.120	-0.090	Good
D3	Cube 3	Line	Point	Distance	8.42	-0.500	0.500	8.405	-0.015	Good
D4	Cube 2	Line	Point	Distance	8.42	-0.500	0.500	8.345	-0.075	Good
E1	Square Base	Line	Point	Distance	151.5	-0.500	0.500	150.711	-0.789	Low
E2	Wedge Y	Line	Point	Distance	25.25	-0.500	0.500	24.806	-0.444	Good
E3	Wedge Y	Line	Point	Distance	12.63	-0.500	0.500	12.269	-0.361	Good
E4	Wedge Y	Line	Point	Distance	6.73	-0.500	0.500	6.661	-0.069	Good
E5	Cube 4	Line	Point	Distance	8.42	-0.500	0.500	8.305	-0.115	Good
E6	Rectangular Hole	Line	Point	Distance	8.42	-0.500	0.500	8.348	-0.072	Good
E7	Rectangular Hole	Line	Point	Distance	25.25	-0.500	0.500	24.997	-0.253	Good
E8	Cube 3	Line	Point	Distance	8.42	-0.500	0.500	8.345	-0.075	Good
E9	Cube 3	Line	Point	Distance	8.42	-0.500	0.500	8.433	0.013	Good
E10	Cylinder Inner Diameter	Line	Point	Distance	21.04	-0.500	0.500	20.888	-0.152	Good
E11	Cylinder Outer Diameter	Line	Point	Distance	29.46	-0.500	0.500	29.195	-0.265	Good
E12	Square Base	Line	Point	Distance	151.5	-0.500	0.500	150.827	-0.673	Low
EE1	Triangular Hole	Line	Point	Distance	5.89	-0.500	0.500	5.716	-0.174	Good
EE2	Thin Walls	Line	Point	Distance	4.21	-0.500	0.500	4.132	-0.078	Good
EE3	Thin Walls	Line	Point	Distance	2.53	-0.500	0.500	2.511	-0.019	Good
AA2	Wedge X-direction	Line	Line	Angularity	75	-0.500	0.500	74.387	-0.613	Low
AA3	Wedge X-direction	Line	Line	Angularity	75	-0.500	0.500	76.682	1.682	High
BB2	Wedge Y-direction	Line	Line	Angularity	60	-0.500	0.500	60.440	0.440	Good
BB3	Wedge Y-direction	Line	Line	Angularity	75	-0.500	0.500	75.408	0.408	Good
CC1	Pyramid	Line	Line	Angularity	106.7	-0.500	0.500	105.876	-0.824	Low
CC2	Pyramid	Line	Line	Angularity	106.7	-0.500	0.500	106.126	-0.574	Low

DD1	Pyramid	Line	Line	Line	Angularity	111.8	-0.500	0.500	111.281	-0.519	Low
DD2	Pyramid	Line	Line	Line	Angularity	111.8	-0.500	0.500	111.246	-0.554	Low
T1	Triangular Hole	Line	Line	Line	Perpendicularity		-0.500	0.500	0.018	0.018	Good
T2	Cylinder Hole/ Hollow Cylinder	Outer Circle	Outer Circle	Inner Circle	Circularity		-0.500	0.500	0.033	0.033	Good
T3	Cylinder Hole/ Hollow Cylinder	Outer Circle	Outer Circle	Inner Circle	Concentricity		-0.500	0.500	0.092	0.092	Good
T4	Cylinder Hole/ Hollow Cylinder	Outer Circle	Outer Circle	Inner Circle	Circularity		-0.500	0.500	0.114	0.114	Good
T5	Square Base	Plane	Plane		Flatness		-0.500	0.500	0.370	0.370	Good
T6	Square Base	Left_Side	Left_Side	Bottom Side	Perpendicularity		-0.500	0.500	0.045	0.045	Good
T7	Square Base	Top_Side	Top_Side	Right Side	Perpendicularity		-0.500	0.500	0.008	0.008	Good
T8	Square Base	Left_Side	Left_Side	Right Side	Parallelism		-0.500	0.500	0.026	0.026	Good
T9	Square Base	Top_Side	Top_Side	Bottom Side	Parallelism		-0.500	0.500	0.026	0.026	Good
T10	Thin Walls	Line	Line	Line	Parallelism		-0.500	0.500	0.044	0.044	Good
T11	Thin Walls	Line	Line	Line	Parallelism		-0.500	0.500	0.167	0.167	Good
T12	Thin Walls	Line	Line	Line	Thickness		-0.500	0.500	0.137	0.137	Good
T13	Thin Walls	Line	Line	Line	Thickness		-0.500	0.500	0.143	0.143	Good
T14	Cube's 2,3,1	Cube231	Cube231		Straightness		-0.500	0.500	0.072	0.072	Good
T15	Cube's 1,4, RecProtr	Cube14Rec	Cube14Rec		Straightness		-0.500	0.500	0.022	0.022	Good
T16	Rectangular Protrusion Outer	RecP2	RecP2	RecP1	Perpendicularity		-0.500	0.500	1.408	1.408	High
T17	Rectangular Protrusion Inner	RecP4	RecP4	RecP3	Perpendicularity		-0.500	0.500	0.055	0.055	Good
T18	Rectangular Hole Outer	RecH4	RecH4	RecH3	Perpendicularity		-0.500	0.500	0.325	0.325	Good
T19	Rectangular Hole Inner	RecH1	RecH1	RecH2	Perpendicularity		-0.500	0.500	0.080	0.080	Good
T23	Cone	Actual Cone Axis	Actual Cone Axis	Cone	Symmetry tol. axis element		-0.500	0.500	0.013	0.013	Good
T24	Cone	Cone Bottom Circle	Cone Bottom Circle	Cone	Circular runout		-0.500	0.500	0.089	0.089	Good
T26	Cone	Cone Bottom Circle	Cone Bottom Circle	Theoretical Cone Axis	Circular runout		-0.500	0.500	0.333	0.333	Good

T29	Cone	plane_2	Cone	Axial runout	-0.500	0.500	0.559	0.559	High
T31	Cone	Cone	plane_2	Symmetry tol. axis element	-0.500	0.500	0.282	0.282	Good
T32	Cone	Cone Bottom Circle	Cone	Symmetry tol. point element	-0.500	0.500	0.035	0.035	Good
T33	Cone	Cone	plane_2	Angularity	-0.500	0.500	0.035	0.035	Good
T34	Cone	Cone	Theoretical Cone Axis	Coaxiality	-0.500	0.500	0.352	0.352	Good
T36	Cone	Cone	Actual Cone Axis	Coaxiality	-0.500	0.500	0.061	0.061	Good
T37	Cone	Cone_Bottom_Circle	Actual Cone Axis	Circular runout	-0.500	0.500	0.083	0.083	Good
T38	Sphere	Sphere Bottom Circle	Sphere Axis	Circular runout	-0.500	0.500	0.386	0.386	Good
T39	Sphere	Sphere Bottom Circle	Actual Sphere Axis	Circular runout	-0.500	0.500	0.112	0.112	Good
T41	Sphere	plane_2	Actual Sphere Axis	Axial runout	-0.500	0.500	6.513	6.513	Good
T42	Sphere	plane_2	Sphere	Symmetry tol. plane element	-0.500	0.500	2.593	2.593	High
T43	Sphere	Theoretical Sphere Axis	Sphere	Symmetry tol. axis element	-0.500	0.500	0.222	0.222	Good
T47	Sphere	Sphere Bottom Circle	Sphere	Symmetry tol. point element	-0.500	0.500	0.222	0.222	Good
T51	Sphere	Actual Sphere Axis	Theoretical Sphere Axis	Coaxiality	-0.500	0.500	0.246	0.246	Good
T52	Sphere	Sphere	Sphere Bottom Circle	Concentricity	-0.500	0.500	0.222	0.222	Good
T54	Dome	Dome Bottom Circle	Actual Dome axis	Circular runout	-0.500	0.500	0.112	0.112	Good
T56	Dome	Dome Upper Circle	Actual Dome axis	Circular runout	-0.500	0.500	0.018	0.018	Good

T58	Dome	plane_2	Actual Dome axis	Axial runout	-0.500	0.500	1.290	1.290	High
T65	Dome	Dome Bottom Circle	Dome Upper Circle	Symmetry tol. point element	-0.500	0.500	0.021	0.021	Good
T67	Dome	plane_2	Actual Dome axis	Perpendicularity	-0.500	0.500	0.258	0.258	Good
T69	Dome	Dome Upper Circle	Dome Bottom Circle	Concentricity	-0.500	0.500	0.083	0.083	Good
T70	Sinkhole	Sinkhole Upper Circle	Theoretical Sinkhole axis	Circular runout	-0.500	0.500	0.761	0.761	High
T71	Sinkhole	Sinkhole Upper Circle	Actual Sinkhole Axis	Circular runout	-0.500	0.500	0.169	0.169	Good
T72	Sinkhole	Sinkhole Bottom Circle	Theoretical Sinkhole axis	Circular runout	-0.500	0.500	0.545	0.545	High
T73	Sinkhole	Sinkhole Bottom Circle	Actual Sinkhole Axis	Circular runout	-0.500	0.500	0.049	0.049	Good
T79	Sinkhole	Theoretical Sinkhole Axis	plane_2	Symmetry tol. axis element	-0.500	0.500	0.177	0.177	Good
T82	Sinkhole	Sinkhole Bottom Circle	Sinkhole Bottom Circle	Symmetry tol. point element	-0.500	0.500	0.171	0.171	Good
T84	Sinkhole	plane_2	Actual Sinkhole Axis	Perpendicularity	-0.500	0.500	0.888	0.888	High
T85	Sinkhole	Actual Sinkhole Axis	Theoretical Sinkhole axis	Coaxiality	-0.500	0.500	0.844	0.844	High
T86	Sinkhole	Sinkhole Bottom Circle	Sinkhole Lower Circle	Concentricity	-0.500	0.500	0.246	0.246	Good

## Feature Tolerances – Polyamide Magnesium Casting

Feature Tolerances - Polyamide Casting Pattern 4												
Tolerance No.	Feature	Tol.ElemName	Compared to	Type of Tolerance	Spec.	Lower Tol.	Upper Tol.	Actual	Tol. Deviation	Result		
A1	Square Base	Line	Point	Distance	58.92	-0.500	0.500	61.018	2.098	High		
A2	Pattern	Line	Point	Distance	71.54	-0.500	0.500	70.689	-0.851	Low		
A3	Pattern	Line	Point	Distance	2.1	-0.500	0.500	0.399	-1.701	Low		
A4	Rectangular Protrusion	Line	Point	Distance	25.25	-0.500	0.500	24.702	-0.548	Low		
A5	Rectangular Protrusion	Line	Point	Distance	8.42	-0.500	0.500	7.848	-0.572	Low		
A6	Rectangular Protrusion	Line	Point	Distance	8.42	-0.500	0.500	8.072	-0.348	Good		
A7	Pattern	Line	Point	Distance	8.42	-0.500	0.500	7.844	-0.576	Low		
A8	Wedge X	Line	Point	Distance	12.63	-0.500	0.500	12.739	0.109	Good		
A9	Cube 1	Line	Point	Distance	8.42	-0.500	0.500	7.873	-0.547	Low		
A10	Cube 1	Line	Point	Distance	8.42	-0.500	0.500	7.959	-0.461	Good		
A11	Cube 1	Line	Point	Distance	8.42	-0.500	0.500	7.696	-0.724	Low		
A12	Rectangular Hole	Line	Point	Distance	25.2	-0.500	0.500	25.565	0.365	Good		
A13	Rectangular Hole	Line	Point	Distance	8.42	-0.500	0.500	8.669	0.249	Good		
A14	Cube 2	Line	Point	Distance	8.42	-0.500	0.500	7.604	-0.816	Low		
A15	Cube 2	Line	Point	Distance	8.42	-0.500	0.500	7.707	-0.713	Low		
A16	Pattern	Line	Point	Distance	2.53	-0.500	0.500	0.762	-1.768	Low		
B1	Square Base	Line	Point	Distance	151.5	-0.500	0.500	150.124	-1.376	Low		
B2	Cube 1	Line	Point	Distance	8.42	-0.500	0.500	8.090	-0.330	Good		
C1	Rectangular Protrusion	Line	Point	Distance	8.42	-0.500	0.500	8.306	-0.114	Good		
C2	Pattern	Line	Point	Distance	1.68	-0.500	0.500	1.300	-0.380	Good		
C3	Rectangular Protrusion	Line	Point	Distance	25.25	-0.500	0.500	24.483	-0.767	Low		
C4	Square Base	Line	Point	Distance	151.5	-0.500	0.500	150.124	-1.376	Low		
C5	Wedge X	Line	Point	Distance	25.25	-0.500	0.500	24.152	-1.098	Low		

C6	Cube 1	Line	Point	Distance	8.42	-0.500	0.500	7.706	-0.714	Low
CC3	Cube 1	Line	Point	Distance	8.42	-0.500	0.500	7.696	-0.724	Low
CC4	Cube 1	Line	Point	Distance	8.42	-0.500	0.500	7.959	-0.461	Good
CC5	Cylinder Depth	Line	Point	Distance	16.83	-0.500	0.500	16.887	0.057	Good
D1	Square Base Depth	Line	Point	Distance	29.46	-0.500	0.500	30.885	1.425	High
D2	Cube 3	Line	Point	Distance	4.21	-0.500	0.500	3.831	-0.379	Good
D3	Cube 3	Line	Point	Distance	8.42	-0.500	0.500	7.863	-0.557	Low
D4	Cube 2	Line	Point	Distance	8.42	-0.500	0.500	7.913	-0.507	Low
E1	Square Base	Line	Point	Distance	151.5	-0.500	0.500	150.229	-1.271	Low
E2	Wedge Y	Line	Point	Distance	25.25	-0.500	0.500	24.207	-1.043	Low
E3	Wedge Y	Line	Point	Distance	12.63	-0.500	0.500	12.125	-0.505	Low
E4	Wedge Y	Line	Point	Distance	6.73	-0.500	0.500	6.184	-0.546	Low
E5	Cube 4	Line	Point	Distance	8.42	-0.500	0.500	7.968	-0.452	Good
E6	Rectangular Hole	Line	Point	Distance	8.42	-0.500	0.500	8.692	0.272	Good
E7	Rectangular Hole	Line	Point	Distance	25.25	-0.500	0.500	25.558	0.308	Good
E8	Cube 3	Line	Point	Distance	8.42	-0.500	0.500	7.884	-0.536	Low
E9	Cube 3	Line	Point	Distance	8.42	-0.500	0.500	8.075	-0.345	Good
E10	Cylinder Inner Diameter	Line	Point	Distance	21.04	-0.500	0.500	21.105	0.065	Good
E11	Cylinder Outer Diameter	Line	Point	Distance	29.46	-0.500	0.500	29.227	-0.233	Good
E12	Square Base	Line	Point	Distance	151.5	-0.500	0.500	150.410	-1.090	Low
EE1	Triangular Hole	Line	Point	Distance	5.89	-0.500	0.500	5.918	0.028	Good
EE2	Thin Walls	Line	Point	Distance	4.21	-0.500	0.500	4.056	-0.154	Good
EE3	Thin Walls	Line	Point	Distance	2.53	-0.500	0.500	2.458	-0.072	Good
AA2	Wedge X-direction	Line	Line	Angularity	75	-0.500	0.500	76.009	1.009	High
AA3	Wedge X-direction	Line	Line	Angularity	75	-0.500	0.500	74.507	-0.493	Good
BB2	Wedge Y-direction	Line	Line	Angularity	60	-0.500	0.500	60.066	0.066	Good
BB3	Wedge Y-direction	Line	Line	Angularity	75	-0.500	0.500	74.647	-0.353	Good
CC1	Pyramid	Line	Line	Angularity	106.7	-0.500	0.500	106.980	0.280	Good
CC2	Pyramid	Line	Line	Angularity	106.7	-0.500	0.500	106.846	0.146	Good

DD1	Pyramid	Line	Line	Line	Angularity	111.8	-0.500	0.500	112.241	0.441	Good
DD2	Pyramid	Line	Line	Line	Angularity	111.8	-0.500	0.500	111.938	0.138	Good
T1	Triangular Hole	Line	Line	Line	Perpendicularity		-0.500	0.500	0.048	0.048	Good
T2	Cylinder Hole/ Hollow Cylinder	Outer Circle	Inner Circle	Inner Circle	Circularity		-0.500	0.500	0.185	0.185	Good
T3	Cylinder Hole/ Hollow Cylinder	Outer Circle	Inner Circle	Inner Circle	Concentricity		-0.500	0.500	0.166	0.166	Good
T4	Cylinder Hole/ Hollow Cylinder	Outer Circle	Inner Circle	Inner Circle	Circularity		-0.500	0.500	0.039	0.039	Good
T5	Square Base	Plane			Flatness		-0.500	0.500	0.219	0.219	Good
T6	Square Base	Left_Side	Bottom Side	Bottom Side	Perpendicularity		-0.500	0.500	0.030	0.030	Good
T7	Square Base	Top_Side	Right Side	Right Side	Perpendicularity		-0.500	0.500	0.078	0.078	Good
T8	Square Base	Left_Side	Right Side	Right Side	Parallelism		-0.500	0.500	0.011	0.011	Good
T9	Square Base	Top_Side	Bottom Side	Bottom Side	Parallelism		-0.500	0.500	0.097	0.097	Good
T10	Thin Walls	Line	Line	Line	Parallelism		-0.500	0.500	0.305	0.305	Good
T11	Thin Walls	Line	Line	Line	Parallelism		-0.500	0.500	0.100	0.100	Good
T12	Thin Walls	Line	Line	Line	Thickness		-0.500	0.500	0.095	0.095	Good
T13	Thin Walls	Line	Line	Line	Thickness		-0.500	0.500	0.130	0.130	Good
T14	Cube's 2,3,1	Cube231			Straightness		-0.500	0.500	0.035	0.035	Good
T15	Cube's 1,4, RecProtr	Cube14Rec			Straightness		-0.500	0.500	0.061	0.061	Good
T16	Rectangular Protrusion Outer	RecP2	RecP1	RecP1	Perpendicularity		-0.500	0.500	0.412	0.412	Good
T17	Rectangular Protrusion Inner	RecP4	RecP3	RecP3	Perpendicularity		-0.500	0.500	0.174	0.174	Good
T18	Rectangular Hole Outer	Rech4	Rech3	Rech3	Perpendicularity		-0.500	0.500	0.061	0.061	Good
T19	Rectangular Hole Inner	Rech1	Rech2	Rech2	Perpendicularity		-0.500	0.500	0.980	0.980	High
T23	Cone	Actual Cone Axis	Cone	Cone	Symmetry tol. axis element		-0.500	0.500	0.095	0.095	Good
T24	Cone	Cone Bottom Circle	Cone	Cone	Circular runout		-0.500	0.500	0.143	0.143	Good
T26	Cone	Cone Bottom Circle	Theoretical Cone Axis	Theoretical Cone Axis	Circular runout		-0.500	0.500	1.021	1.021	High

T29	Cone	plane_2	Cone	plane_2	Axial runout	-0.500	0.500	5.944	5.944	High
T31	Cone	Cone	Cone	plane_2	Symmetry tol. axis element	-0.500	0.500	0.009	0.009	Good
T32	Cone	Cone Bottom Circle	Cone Bottom Circle	Cone	Symmetry tol. point element	-0.500	0.500	0.009	0.009	Good
T33	Cone	Cone	Cone	plane_2	Angularity	-0.500	0.500	0.026	0.026	Good
T34	Cone	Cone	Cone	Theoretical Cone Axis	Coaxiality	-0.500	0.500	0.965	0.965	High
T36	Cone	Cone	Cone	Actual Cone Axis	Coaxiality	-0.500	0.500	0.184	0.184	Good
T37	Cone	Cone Bottom Circle	Cone Bottom Circle	Actual Cone Axis	Circular runout	-0.500	0.500	0.054	0.054	Good
T38	Sphere	Sphere Bottom Circle	Sphere Bottom Circle	Sphere Axis	Circular runout	-0.500	0.500	0.248	0.248	Good
T39	Sphere	Sphere Bottom Circle	Sphere Bottom Circle	Actual Sphere Axis	Circular runout	-0.500	0.500	0.118	0.118	Good
T41	Sphere	plane_2	plane_2	Actual Sphere Axis	Axial runout	-0.500	0.500	1.121	1.121	High
T42	Sphere	plane_2	plane_2	Sphere	Symmetry tol. plane element	-0.500	0.500	4.308	4.308	High
T43	Sphere	Theoretical Sphere Axis	Theoretical Sphere Axis	Sphere	Symmetry tol. axis element	-0.500	0.500	0.224	0.224	Good
T47	Sphere	Sphere Bottom Circle	Sphere Bottom Circle	Sphere	Symmetry tol. point element	-0.500	0.500	0.017	0.017	Good
T51	Sphere	Actual Sphere Axis	Actual Sphere Axis	Theoretical Sphere Axis	Coaxiality	-0.500	0.500	0.257	0.257	Good
T52	Sphere	Sphere	Sphere	Sphere Bottom Circle	Concentricity	-0.500	0.500	0.018	0.018	Good
T54	Dome	Dome Bottom Circle	Dome Bottom Circle	Actual Dome axis	Circular runout	-0.500	0.500	0.077	0.077	Good
T56	Dome	Dome Upper Circle	Dome Upper Circle	Actual Dome axis	Circular runout	-0.500	0.500	0.026	0.026	Good

T58	Dome	plane_2	Actual Dome axis	Axial runout		-0.500	0.500	0.222	0.222	Good
		Dome Bottom Circle	Dome Upper Circle	Symmetry tol. point element		-0.500	0.500	0.083	0.083	Good
T65	Dome	plane_2	Actual Dome axis	Perpendicularity		-0.500	0.500	0.171	0.171	Good
T67	Dome	Dome Upper Circle	Dome Bottom Circle	Concentricity		-0.500	0.500	0.093	0.093	Good
T69	Dome		Theoretical Sinkhole axis	Circular runout		-0.500	0.500	0.678	0.678	Good
T70	Sinkhole	Sinkhole Upper Circle	Actual Sinkhole Axis	Circular runout		-0.500	0.500	0.069	0.069	High
T71	Sinkhole	Sinkhole Bottom Circle	Theoretical Sinkhole axis	Circular runout		-0.500	0.500	0.816	0.816	Good
T72	Sinkhole	Sinkhole Bottom Circle	Actual Sinkhole Axis	Circular runout		-0.500	0.500	0.074	0.074	High
T73	Sinkhole	Theoretical Sinkhole Axis	plane_2	Symmetry tol. axis element		-0.500	0.500	0.043	0.043	Good
T79	Sinkhole	Sinkhole Bottom Circle	Sinkhole Bottom Circle	Symmetry tol. point element		-0.500	0.500	0.087	0.087	Good
T82	Sinkhole	plane_2	Actual Sinkhole Axis	Perpendicularity		-0.500	0.500	0.635	0.635	Good
T84	Sinkhole	Actual Sinkhole Axis	Theoretical Sinkhole axis	Coaxiality		-0.500	0.500	0.620	0.620	High
T85	Sinkhole		Sinkhole Lower Circle	Concentricity		-0.500	0.500	0.155	0.155	High
T86	Sinkhole	Sinkhole Bottom Circle								Good

*Appendix F      Magnesium Castings -  
Statistical CMM Raw  
Data (3D-Tol Data)*

### 3D-Tol Data from CMM for 3DP Magnesium Casting

MEAS X	MEAS Y	MEAS Z	CAD X	CAD Y	CAD Z	DIF X	DIF Y	DIF Z	TOT DIF
53.779	59.104	-6.078	53.779	58.917	-6.078	0	0.187	0	0.187
37.233	59.121	-6.081	37.233	58.917	-6.081	0	0.204	0	0.204
20.688	59.165	-6.085	20.688	58.917	-6.085	0	0.248	0	0.248
4.143	59.001	-6.089	4.143	58.917	-6.089	0	0.084	0	0.084
-12.402	58.907	-6.093	-12.402	58.917	-6.093	0	-0.009	0	-0.009
-28.946	59.156	-6.098	-28.946	58.917	-6.098	0	0.24	0	0.24
-45.491	58.972	-6.101	-45.491	58.917	-6.101	0	0.055	0	0.055
-62.037	58.546	-6.106	-62.037	58.917	-6.106	0	-0.371	0	-0.371
-79.74	41.099	-6.099	-79.958	41.099	-6.099	0.218	0	0	-0.218
-80.01	24.554	-6.086	-79.958	24.554	-6.086	-0.051	0	0	0.051
-80.001	8.01	-6.074	-79.958	8.01	-6.074	-0.043	0	0	0.043
-79.889	-8.536	-6.062	-79.958	-8.536	-6.062	0.07	0	0	-0.07
-79.84	-25.08	-6.051	-79.958	-25.08	-6.051	0.118	0	0	-0.118
-80.049	-41.624	-6.039	-79.958	-41.624	-6.039	-0.091	0	0	0.091
-79.844	-58.17	-6.029	-79.958	-58.17	-6.029	0.115	0	0	-0.115
-79.677	-74.715	-6.015	-79.958	-74.715	-6.015	0.281	0	0	-0.281
-62.16	-92.576	-5.997	-62.16	-92.583	-5.997	0	0.007	0	-0.007
-45.614	-92.639	-5.992	-45.614	-92.583	-5.992	0	-0.056	0	0.056
-29.07	-92.544	-5.988	-29.07	-92.583	-5.988	0	0.039	0	-0.039
-12.525	-92.67	-5.983	-12.525	-92.583	-5.983	0	-0.086	0	0.086
4.02	-92.869	-5.98	4.02	-92.583	-5.98	0	-0.285	0	0.285
20.565	-92.772	-5.975	20.565	-92.583	-5.975	0	-0.188	0	0.188
37.109	-92.79	-5.971	37.109	-92.583	-5.971	0	-0.207	0	0.207
53.653	-92.609	-5.967	53.653	-92.583	-5.967	0	-0.026	0	0.026
71.608	-74.839	-5.976	71.542	-74.839	-5.976	0.066	0	0	0.066
71.757	-58.294	-5.987	71.542	-58.294	-5.987	0.216	0	0	0.216
71.846	-41.75	-6	71.542	-41.75	-6	0.304	0	0	0.304
71.656	-25.205	-6.011	71.542	-25.205	-6.011	0.115	0	0	0.115
71.773	-8.66	-6.022	71.542	-8.66	-6.022	0.231	0	0	0.231
71.84	7.885	-6.033	71.542	7.885	-6.033	0.298	0	0	0.298
71.642	24.429	-6.046	71.542	24.429	-6.046	0.101	0	0	0.101
71.509	40.974	-6.057	71.542	40.974	-6.057	-0.033	0	0	-0.033
-69.795	43.795	8.641	-69.795	43.795	8.417	0	0	0.225	0.225
-64.745	43.792	8.695	-64.745	43.792	8.417	0	0	0.278	0.278
-64.742	48.842	8.739	-64.742	48.842	8.417	0	0	0.322	0.322
-69.792	48.846	8.607	-69.792	48.846	8.417	0	0	0.19	0.19
-67.663	46.44	8.64	-67.663	46.44	8.417	0	0	0.224	0.224
-71.719	43.795	6.527	-71.542	43.795	6.527	-0.177	0	0	0.177
-71.645	48.843	6.524	-71.542	48.843	6.524	-0.103	0	0	0.103

-69.788	50.499	6.523	-69.788	50.5	6.523	0	-0.001	0	-0.001
-64.737	50.468	6.525	-64.737	50.5	6.525	0	-0.032	0	-0.032
-64.745	42.191	6.532	-64.745	42.083	6.532	0	0.107	0	-0.107
-69.796	41.971	6.532	-69.796	42.083	6.532	0	-0.112	0	0.112
-63.425	48.837	6.529	-63.125	48.837	6.529	-0.3	0	0	-0.3
-63.424	43.788	6.532	-63.125	43.788	6.532	-0.299	0	0	-0.299
-64.793	-14.286	4.097	-64.793	-14.286	4.208	0	0	-0.112	-0.112
-69.843	-14.282	4.134	-69.843	-14.282	4.208	0	0	-0.075	-0.075
-69.845	-19.333	4.021	-69.845	-19.333	4.208	0	0	-0.188	-0.188
-64.796	-19.336	4.059	-64.796	-19.336	4.208	0	0	-0.15	-0.15
-67.966	-16.711	4.021	-67.966	-16.711	4.208	0	0	-0.187	-0.187
-69.839	-12.382	3.2	-69.839	-12.625	3.2	0	0.243	0	0.243
-64.789	-12.457	3.202	-64.789	-12.625	3.202	0	0.168	0	0.168
-63.035	-14.29	4.053	-63.125	-14.29	4.208	0.09	0	-0.155	0.179
-63.032	-19.339	4.051	-63.125	-19.339	4.208	0.093	0	-0.157	0.183
-64.797	-20.989	3.21	-64.797	-21.042	3.21	0	0.052	0	-0.052
-69.847	-21.083	3.209	-69.847	-21.042	3.209	0	-0.042	0	0.042
-71.787	-19.333	3.204	-71.542	-19.333	3.204	-0.246	0	0	0.246
-71.809	-14.282	3.201	-71.542	-14.282	3.201	-0.268	0	0	0.268
-64.846	-77.408	8.496	-64.846	-77.408	8.417	0	0	0.08	0.08
-69.897	-77.404	8.474	-69.897	-77.404	8.417	0	0	0.057	0.057
-69.901	-82.455	8.375	-69.901	-82.455	8.417	0	0	-0.042	-0.042
-64.849	-82.458	8.516	-64.849	-82.458	8.417	0	0	0.1	0.1
-69.892	-75.68	6.611	-69.892	-75.75	6.611	0	0.07	0	0.07
-64.843	-75.56	6.614	-64.843	-75.75	6.614	0	0.19	0	0.19
-63.376	-77.412	6.617	-63.125	-77.412	6.617	-0.251	0	0	-0.251
-63.446	-82.463	6.621	-63.125	-82.463	6.621	-0.321	0	0	-0.321
-64.85	-84.166	6.62	-64.85	-84.167	6.62	0	0	0	0
-69.901	-84.453	6.62	-69.901	-84.167	6.62	0	-0.286	0	0.286
-71.2	-82.456	6.615	-71.542	-82.456	6.615	0.341	0	0	-0.341
-71.268	-77.405	6.612	-71.542	-77.405	6.612	0.273	0	0	-0.273
-2.46	43.736	4.287	-2.46	43.736	4.208	0	0	0.079	0.079
2.59	43.733	4.277	2.59	43.733	4.208	0	0	0.069	0.069
2.593	48.783	4.304	2.593	48.783	4.208	0	0	0.096	0.096
-2.457	48.786	4.291	-2.457	48.786	4.208	0	0	0.083	0.083
-0.619	46.771	4.276	-0.619	46.771	4.208	0	0	0.068	0.068
-4.417	43.735	1.915	-4.208	43.735	1.915	-0.208	0	0	0.208
-4.545	48.786	1.913	-4.208	48.786	1.913	-0.337	0	0	0.337
2.59	42.266	1.92	2.59	42.083	1.92	0	0.182	0	-0.182
-2.461	42.177	1.919	-2.461	42.083	1.919	0	0.094	0	-0.094
3.897	48.778	1.916	4.208	48.778	1.916	-0.312	0	0	-0.312

4.12	43.728	1.921	4.208	43.728	1.921	-0.089	0	0	-0.089
-2.453	50.92	1.911	-2.453	50.5	1.911	0	0.42	0	0.42
2.597	50.62	1.913	2.597	50.5	1.913	0	0.12	0	0.12
-64.873	36.378	-1.459	-64.747	36.253	-1.459	-0.126	0.126	0	-0.178
-54.076	47.01	-1.463	-54.033	46.967	-1.463	-0.043	0.043	0	-0.061
-46.875	46.917	-1.463	-46.896	46.896	-1.463	0.021	0.021	0	-0.03
-36.114	36.251	-1.453	-36.182	36.182	-1.453	0.068	0.068	0	-0.097
-41.117	28.874	-1.448	-40.947	29.044	-1.448	-0.17	-0.17	0	-0.24
-48.372	35.904	-1.456	-48.09	36.187	-1.456	-0.283	-0.283	0	-0.4
-35.925	29.802	-1.831	-35.707	29.584	-1.831	-0.218	0.218	0	0.308
-54.029	35.052	-1.459	-54.037	35.06	-1.459	0.008	-0.008	0	-0.011
-58.734	30.23	-1.457	-58.8	30.297	-1.457	0.066	-0.066	0	-0.094
-65.658	29.312	-1.357	-65.339	29.63	-1.357	-0.318	-0.318	0	-0.45
-61.337	33.573	-4.051	-61.337	33.573	-4.208	0	0	0.158	0.158
-56.765	38.324	-4.006	-56.765	38.324	-4.208	0	0	0.202	0.202
-50.265	43.722	-3.919	-50.265	43.722	-4.208	0	0	0.289	0.289
-44.71	38.67	-3.914	-44.71	38.67	-4.208	0	0	0.295	0.295
-40.039	33.857	-4.037	-40.039	33.857	-4.208	0	0	0.171	0.171
49.722	42.228	5.719	49.722	42.083	5.719	0	0.145	0	-0.145
42.988	42.077	5.718	42.988	42.083	5.718	0	-0.006	0	0.006
54.772	30.222	5.727	54.708	30.222	5.727	0.064	0	0	-0.064
54.7	36.957	5.722	54.708	36.957	5.722	-0.008	0	0	0.008
58.849	25.201	5.24	58.849	25.25	5.24	0	-0.049	0	0.049
63.186	30.215	5.732	63.125	30.215	5.732	0.061	0	0	0.061
63.257	37.792	5.726	63.125	37.792	5.726	0.132	0	0	0.132
63.113	45.367	5.72	63.125	45.367	5.72	-0.012	0	0	-0.012
58.146	51.075	5.713	58.146	50.5	5.713	0	0.575	0	0.575
50.568	51.071	5.712	50.568	50.5	5.712	0	0.571	0	0.571
42.994	51.039	5.71	42.994	50.5	5.71	0	0.539	0	0.539
37.843	46.178	4.994	37.875	46.178	4.994	-0.032	0	0	0.032
43.24	46.346	8.501	43.24	46.346	8.417	0	0	0.085	0.085
50.472	46.05	8.46	50.472	46.05	8.417	0	0	0.044	0.044
58.443	45.712	8.379	58.443	45.712	8.417	0	0	-0.037	-0.037
59.177	37.447	8.492	59.177	37.447	8.417	0	0	0.075	0.075
59.047	30.601	8.507	59.047	30.601	8.417	0	0	0.09	0.09
-30.837	48.704	16.86	-30.837	48.782	16.815	0	-0.078	0.045	0.09
-30.838	45.797	11.837	-30.838	45.88	11.789	0	-0.083	0.048	0.096
-30.839	42.845	6.842	-30.839	42.979	6.764	0	-0.135	0.078	0.155
-30.84	40.018	1.772	-30.84	40.077	1.738	0	-0.059	0.034	0.069
-27.051	39.971	1.799	-27.051	40.077	1.737	0	-0.106	0.061	0.122
-27.052	42.961	6.774	-27.052	42.979	6.763	0	-0.018	0.01	0.021

-27.051	45.761	11.857	-27.051	45.88	11.788	0	-0.119	0.069	0.137
-27.05	48.686	16.87	-27.05	48.782	16.815	0	-0.096	0.055	0.111
-23.261	48.772	16.819	-23.261	48.781	16.814	0	-0.009	0.005	0.011
-23.262	45.835	11.814	-23.262	45.88	11.788	0	-0.044	0.026	0.051
-23.263	42.924	6.795	-23.263	42.979	6.763	0	-0.054	0.031	0.063
-23.265	40.13	1.706	-23.265	40.077	1.737	0	0.053	-0.031	-0.061
-16.948	45.373	1.699	-16.948	45.361	1.702	0	0.012	-0.003	-0.013
-16.95	47.453	9.219	-16.95	47.381	9.239	0	0.073	-0.019	-0.075
-16.95	49.526	16.745	-16.95	49.401	16.778	0	0.125	-0.034	-0.13
-11.897	49.533	16.742	-11.897	49.401	16.778	0	0.132	-0.035	-0.137
-11.898	47.451	9.219	-11.898	47.38	9.238	0	0.071	-0.019	-0.073
-11.898	45.521	1.659	-11.898	45.361	1.702	0	0.16	-0.043	-0.166
-8.711	49.593	7.335	-8.178	49.593	7.335	-0.533	0	0	-0.533
-30.833	51.273	14.959	-30.833	51.015	14.89	0	0.258	0.069	0.267
-30.833	52.945	9.346	-30.833	52.531	9.235	0	0.414	0.111	0.429
-30.831	54.338	3.66	-30.831	54.045	3.582	0	0.293	0.079	0.303
-24.096	54.266	3.644	-24.096	54.045	3.585	0	0.221	0.059	0.229
-24.099	52.851	9.326	-24.099	52.529	9.24	0	0.321	0.086	0.333
-24.102	51.345	14.983	-24.102	51.014	14.894	0	0.331	0.089	0.343
-17.367	51.391	14.999	-17.367	51.013	14.898	0	0.377	0.101	0.391
-17.366	52.902	9.341	-17.366	52.529	9.241	0	0.373	0.1	0.386
-17.364	54.429	3.691	-17.364	54.044	3.588	0	0.385	0.103	0.398
-10.629	54.473	3.706	-10.629	54.043	3.591	0	0.43	0.115	0.445
-10.631	53.097	9.397	-10.631	52.528	9.245	0	0.569	0.152	0.589
-10.635	51.566	15.048	-10.635	51.013	14.9	0	0.553	0.148	0.573
-33.573	48.957	9.471	-33.428	48.957	9.471	-0.145	0	0	0.145
5.05	-63.152	18.729	5.021	-63.152	18.737	0.03	0	-0.008	-0.031
3.182	-63.156	11.654	3.127	-63.156	11.668	0.055	0	-0.015	-0.057
1.247	-63.16	4.596	1.233	-63.16	4.6	0.014	0	-0.004	-0.015
1.367	-69.892	4.567	1.233	-69.892	4.603	0.134	0	-0.036	-0.139
3.328	-69.888	11.617	3.127	-69.888	11.67	0.201	0	-0.054	-0.208
5.054	-69.884	18.732	5.022	-69.884	18.741	0.033	0	-0.009	-0.034
5.127	-76.62	18.715	5.022	-76.62	18.743	0.105	0	-0.028	-0.109
3.077	-76.623	11.688	3.128	-76.623	11.674	-0.051	0	0.014	0.053
1.409	-76.626	4.56	1.234	-76.626	4.607	0.174	0	-0.047	-0.181
1.458	-83.36	4.549	1.235	-83.36	4.609	0.223	0	-0.06	-0.231
3.472	-83.355	11.587	3.129	-83.355	11.679	0.342	0	-0.092	-0.354
5.363	-83.351	18.656	5.023	-83.351	18.747	0.34	0	-0.091	-0.352
7.416	-86.092	10.269	7.416	-85.85	10.269	0	-0.242	0	0.242
7.874	-83.353	21.246	7.704	-83.353	21.148	0.169	0	0.098	0.196
13.152	-83.361	11.732	13.143	-83.361	11.727	0.009	0	0.005	0.01

18.518	-83.373	2.265	18.584	-83.373	2.304	-0.066	0	-0.038	-0.076
18.644	-75.796	2.329	18.588	-75.796	2.297	0.056	0	0.032	0.065
13.099	-75.789	11.696	13.146	-75.789	11.723	-0.047	0	-0.027	-0.054
7.909	-75.777	21.261	7.707	-75.777	21.144	0.202	0	0.117	0.233
7.09	-69.463	21.144	6.968	-69.463	21.112	0.122	0	0.033	0.126
9.477	-69.472	11.685	9.493	-69.472	11.689	-0.016	0	-0.004	-0.016
12.097	-69.481	2.289	12.017	-69.481	2.268	0.08	0	0.021	0.083
12.031	-64.432	2.265	12.019	-64.432	2.261	0.012	0	0.003	0.013
9.351	-64.424	11.646	9.494	-64.424	11.684	-0.143	0	-0.038	-0.148
7.015	-64.415	21.12	6.969	-64.415	21.108	0.046	0	0.012	0.048
6.421	-60.436	10.997	6.421	-60.6	10.997	0	0.164	0	0.164
-30.525	-50.771	-5.245	-30.539	-50.552	-5.494	0.014	-0.219	0.249	0.332
-30.245	-55.199	-7.712	-30.25	-55.121	-7.859	0.005	-0.078	0.147	0.166
-30.024	-58.739	-11.634	-30.033	-58.615	-11.699	0.008	-0.124	0.065	0.14
-29.836	-61.732	-15.768	-29.843	-61.627	-15.918	0.007	-0.104	0.15	0.183
-33.705	-63.566	-15.821	-33.749	-63.526	-15.906	0.044	-0.039	0.084	0.103
-35.736	-61.742	-11.515	-35.986	-61.519	-11.69	0.25	-0.223	0.175	0.378
-38.553	-59.211	-7.739	-38.597	-59.171	-7.851	0.044	-0.04	0.112	0.127
-41.832	-56.267	-5.22	-42.005	-56.113	-5.48	0.173	-0.154	0.26	0.348
-46.149	-68.104	-5.305	-46.291	-68.111	-5.463	0.142	0.007	0.158	0.212
-41.634	-67.899	-7.694	-41.713	-67.903	-7.843	0.079	0.004	0.149	0.169
-38.187	-67.749	-11.676	-38.196	-67.749	-11.681	0.009	0	0.005	0.01
-35.344	-67.623	-16.082	-35.208	-67.616	-15.891	-0.136	-0.007	-0.191	-0.234
-33.513	-71.693	-16.146	-33.385	-71.556	-15.884	-0.128	-0.137	-0.262	-0.322
-35.479	-73.809	-11.723	-35.416	-73.742	-11.675	-0.062	-0.067	-0.048	-0.104
-37.762	-76.256	-7.684	-37.819	-76.317	-7.841	0.056	0.061	0.158	0.178
-40.773	-79.493	-5.183	-40.941	-79.674	-5.458	0.168	0.181	0.274	0.369
-29.722	-67.423	-17.41	-29.784	-67.444	-16.88	0.062	0.021	-0.53	-0.534
-26.764	-62.391	-15.808	-26.725	-62.32	-15.924	-0.039	-0.071	0.116	0.142
-25.362	-59.822	-11.609	-25.276	-59.664	-11.703	-0.086	-0.158	0.094	0.203
-23.663	-56.719	-7.61	-23.598	-56.6	-7.864	-0.065	-0.119	0.254	0.288
-21.541	-52.836	-5.173	-21.402	-52.582	-5.501	-0.139	-0.254	0.329	0.438
-13.514	-62.68	-5.268	-13.32	-62.623	-5.498	-0.194	-0.057	0.229	0.306
-17.787	-63.927	-7.725	-17.716	-63.906	-7.862	-0.07	-0.02	0.137	0.155
-21.23	-64.943	-11.611	-21.068	-64.896	-11.699	-0.162	-0.047	0.088	0.191
-23.957	-65.744	-15.936	-23.967	-65.747	-15.92	0.01	0.003	-0.016	-0.019
-24.416	-70.134	-15.96	-24.448	-70.117	-15.909	0.031	-0.017	-0.051	-0.062
-21.578	-71.68	-11.437	-21.662	-71.634	-11.385	0.084	-0.046	-0.051	-0.108
-18.761	-73.218	-7.792	-18.731	-73.235	-7.856	-0.03	0.016	0.064	0.073
-14.843	-75.36	-5.307	-14.707	-75.435	-5.482	-0.136	0.075	0.175	0.234
-24.771	-83.473	-5.41	-24.758	-83.518	-5.461	-0.013	0.044	0.051	0.069

-26.033	-79.146	-7.924	-26.045	-79.107	-7.848	0.011	-0.039	-0.076	-0.086
-27.002	-75.845	-11.739	-27.033	-75.738	-11.681	0.031	-0.108	-0.059	-0.126
-27.84	-72.981	-16.062	-27.873	-72.865	-15.893	0.033	-0.116	-0.17	-0.208
-32.342	-72.583	-16.197	-32.235	-72.387	-15.884	-0.108	-0.196	-0.312	-0.384
-33.74	-75.129	-11.752	-33.67	-75.002	-11.676	-0.07	-0.127	-0.076	-0.163
-35.353	-78.071	-7.804	-35.363	-78.089	-7.842	0.01	0.018	0.038	0.043
-37.247	-81.53	-4.74	-37.561	-82.102	-5.468	0.314	0.572	0.728	0.978
-25.44	-86.422	-0.821	-25.477	-86.246	-0.611	0.037	-0.177	-0.21	-0.277
-13.016	-77.258	-0.878	-13.084	-77.218	-0.804	0.068	-0.041	-0.074	-0.108
-11.138	-61.811	-0.758	-11.12	-61.805	-0.776	-0.018	-0.005	0.018	0.026
-16.255	-53.695	-0.571	-16.123	-53.559	-0.757	-0.132	-0.136	0.186	0.265
-25.841	-48.457	-0.466	-25.819	-48.342	-0.603	-0.022	-0.115	0.137	0.18
-47.437	-37.833	18.651	-47.157	-37.699	18.83	-0.28	-0.134	-0.179	-0.359
-44.053	-36.236	12.393	-43.86	-36.145	12.516	-0.193	-0.092	-0.123	-0.246
-40.685	-34.647	6.125	-40.563	-34.589	6.203	-0.122	-0.058	-0.078	-0.156
-39.851	-41.303	6.121	-39.697	-41.332	6.211	-0.154	0.029	-0.09	-0.18
-43.442	-40.623	12.43	-43.279	-40.653	12.526	-0.162	0.03	-0.095	-0.191
-47.141	-39.921	18.673	-46.86	-39.973	18.838	-0.282	0.052	-0.165	-0.331
-47.95	-41.997	18.85	-47.958	-41.988	18.843	0.009	-0.009	0.007	0.014
-45.458	-44.639	12.528	-45.457	-44.64	12.529	-0.001	0.001	-0.001	-0.001
-42.909	-47.347	6.256	-42.959	-47.294	6.215	0.049	-0.052	0.042	0.083
-49.096	-50.276	6.262	-49.106	-50.2	6.218	0.01	-0.076	0.044	0.089
-49.569	-46.6	12.539	-49.571	-46.585	12.53	0.002	-0.015	0.009	0.018
-50.026	-43.028	18.88	-50.034	-42.968	18.845	0.008	-0.06	0.035	0.069
-52.318	-42.593	18.873	-52.29	-42.54	18.839	-0.029	-0.052	0.034	0.069
-54.085	-45.822	12.579	-54.039	-45.739	12.525	-0.046	-0.083	0.055	0.109
-55.845	-49.039	6.28	-55.788	-48.936	6.212	-0.056	-0.103	0.068	0.136
-51.944	-39.967	22.664	-51.878	-39.936	22.621	-0.066	-0.031	0.042	0.084
-57.301	-42.498	12.614	-57.152	-42.428	12.519	-0.149	-0.07	0.095	0.19
-62.757	-45.081	2.63	-62.423	-44.924	2.417	-0.334	-0.158	0.213	0.427
-63.848	-36.774	2.642	-63.456	-36.848	2.412	-0.392	0.074	0.23	0.461
-57.868	-37.895	12.598	-57.723	-37.923	12.513	-0.144	0.028	0.085	0.17
-51.984	-39.005	22.609	-51.993	-39.004	22.614	0.009	-0.002	-0.005	-0.01
-51.477	-38.256	22.553	-51.542	-38.186	22.608	0.065	-0.07	-0.055	-0.11
-55.667	-33.812	12.611	-55.543	-33.943	12.507	-0.123	0.131	0.104	0.208
-59.728	-29.507	2.559	-59.545	-29.701	2.406	-0.183	0.194	0.154	0.308
-52.192	-26.119	2.466	-52.179	-26.219	2.407	-0.013	0.101	0.059	0.117
-51.456	-31.873	12.583	-51.439	-32.003	12.507	-0.017	0.13	0.076	0.151
-50.682	-37.92	22.533	-50.699	-37.789	22.61	0.017	-0.131	-0.076	-0.153
-49.888	-38.193	22.462	-49.77	-37.963	22.611	-0.118	-0.229	-0.149	-0.298
-46.893	-32.688	12.613	-46.978	-32.843	12.511	0.085	0.155	0.102	0.204

-44.192	-27.753	2.394	-44.178	-27.728	2.411	-0.014	-0.025	-0.016	-0.032
-45.872	3.631	25.412	-46.107	3.857	25.098	0.236	-0.226	0.314	0.453
-50.399	7.905	27.804	-50.327	7.837	27.503	-0.072	0.068	0.301	0.317
-53.969	11.271	21.861	-53.763	11.076	21.739	-0.206	0.195	0.122	0.309
-56.657	13.81	8.155	-56.442	13.606	8.101	-0.215	0.204	0.054	0.301
-62.22	-1.619	8.189	-61.799	-1.585	8.112	-0.421	-0.034	0.077	0.429
-58.47	-1.308	21.903	-58.122	-1.28	21.753	-0.348	-0.028	0.15	0.38
-53.532	-0.905	27.902	-53.405	-0.895	27.508	-0.127	-0.01	0.393	0.413
-47.418	-0.412	25.29	-47.63	-0.428	25.086	0.211	0.016	0.204	0.294
-45.235	-4.137	25.438	-45.456	-4.427	25.088	0.22	0.289	0.35	0.505
-49.016	-9.078	27.724	-48.974	-9.023	27.51	-0.042	-0.055	0.214	0.225
-52.077	-13.082	21.924	-51.848	-12.783	21.761	-0.228	-0.299	0.162	0.41
-54.259	-15.953	8.176	-54.083	-15.721	8.123	-0.177	-0.231	0.053	0.296
-38.429	-19.379	8.117	-38.418	-19.434	8.127	-0.01	0.055	-0.01	-0.057
-39.092	-15.849	21.776	-39.1	-15.808	21.759	0.008	-0.04	0.018	0.045
-39.951	-11.254	27.794	-39.968	-11.162	27.507	0.017	-0.092	0.287	0.302
-41.166	-4.742	25.819	-41.025	-5.475	25.1	-0.142	0.733	0.719	1.036
-40.277	19.753	8.107	-40.282	19.7	8.098	0.005	0.053	0.01	0.054
-40.607	16.133	21.772	-40.616	16.033	21.729	0.009	0.1	0.043	0.109
-41.029	11.454	27.834	-41.039	11.342	27.497	0.01	0.112	0.337	0.355
-41.6	5.077	25.579	-41.554	5.561	25.11	-0.046	-0.484	0.469	0.675
-39.054	3.954	25.704	-38.683	4.438	25.115	-0.371	-0.484	0.589	0.848
-35.113	9.12	27.744	-35.164	9.054	27.496	0.051	0.066	0.248	0.261
-32.362	12.714	21.688	-32.304	12.79	21.729	-0.058	-0.076	-0.041	-0.104
-30.268	15.442	8.042	-30.063	15.71	8.103	-0.205	-0.268	-0.061	-0.343
-23.937	6.749	8.03	-23.543	6.895	8.106	-0.393	-0.146	-0.076	-0.426
-27.335	5.495	21.575	-26.997	5.621	21.73	-0.338	-0.126	-0.155	-0.393
-31.36	4.002	27.653	-31.409	3.984	27.496	0.049	0.018	0.157	0.165
-37.503	1.722	25.789	-36.85	1.967	25.115	-0.653	-0.245	0.674	0.97
-37.195	-0.995	25.69	-36.608	-1.114	25.112	-0.587	0.119	0.579	0.833
-30.85	-2.323	27.761	-30.935	-2.306	27.499	0.085	-0.018	0.261	0.276
-26.595	-3.215	21.62	-26.324	-3.272	21.74	-0.271	0.056	-0.119	-0.301
-23.114	-3.954	8.043	-22.721	-4.036	8.116	-0.393	0.082	-0.073	-0.408
-27.919	-13.652	8.103	-27.843	-13.725	8.123	-0.076	0.073	-0.019	-0.107
-30.499	-11.159	21.75	-30.495	-11.163	21.752	-0.004	0.003	-0.002	-0.005
-33.831	-7.934	27.726	-33.884	-7.883	27.503	0.053	-0.051	0.223	0.235
-38.545	-3.373	25.774	-38.043	-3.852	25.106	-0.502	0.478	0.669	0.963
-42.099	5.163	25.517	-42.1	5.585	25.11	0.001	-0.422	0.408	0.587
-42.157	11.457	27.698	-42.157	11.39	27.498	0	0.067	0.2	0.211
-42.195	16.248	21.796	-42.194	16.099	21.732	-0.001	0.15	0.064	0.163
-42.222	19.794	8.1	-42.222	19.782	8.098	0	0.012	0.002	0.013

-41.267	0.856	20.496	-40.805	1.341	20.085	-0.462	-0.485	0.411	0.786
-44.692	0.254	21.64	-44.85	0.269	21.534	0.158	-0.015	0.106	0.191
-41.097	-1.721	21.673	-40.789	-2.258	21.267	-0.308	0.537	0.406	0.74
45.075	-41.404	15.263	45.085	-41.385	15.126	-0.01	-0.019	0.137	0.138
42.411	-46.268	13.375	42.44	-46.215	13.265	-0.029	-0.053	0.11	0.125
40.239	-50.239	9.688	40.261	-50.199	9.647	-0.022	-0.04	0.041	0.061
38.752	-52.969	4.766	38.809	-52.864	4.718	-0.057	-0.105	0.047	0.128
31.948	-44.791	4.633	31.746	-44.871	4.72	0.203	0.08	-0.087	-0.234
34.67	-43.723	9.572	34.58	-43.759	9.658	0.09	0.036	-0.086	-0.13
38.786	-42.117	13.344	38.821	-42.104	13.277	-0.034	-0.014	0.068	0.077
43.945	-40.105	15.221	43.958	-40.1	15.13	-0.013	-0.005	0.091	0.092
43.896	-38.382	15.278	43.916	-38.389	15.136	-0.02	0.006	0.142	0.144
38.625	-36.602	13.398	38.68	-36.621	13.29	-0.056	0.018	0.108	0.123
34.495	-35.204	9.547	34.358	-35.159	9.675	0.137	-0.045	-0.128	-0.193
31.738	-34.276	4.613	31.462	-34.184	4.729	0.275	-0.092	-0.116	-0.313
38.15	-25.817	4.733	38.139	-25.799	4.742	0.011	-0.018	-0.008	-0.022
39.796	-28.526	9.582	39.731	-28.42	9.693	0.065	-0.106	-0.111	-0.166
42.086	-32.284	13.401	42.112	-32.327	13.306	-0.027	0.044	0.095	0.108
44.973	-37.035	15.295	44.985	-37.054	15.141	-0.012	0.019	0.154	0.156
46.668	-36.695	15.302	46.664	-36.718	15.143	0.004	0.023	0.159	0.16
47.521	-31.111	13.564	47.501	-31.246	13.31	0.021	0.135	0.254	0.288
48.233	-26.477	9.921	48.195	-26.722	9.7	0.037	0.244	0.221	0.332
48.678	-23.58	4.793	48.661	-23.688	4.749	0.017	0.108	0.044	0.118
38.751	-52.97	4.767	38.809	-52.864	4.719	-0.058	-0.106	0.048	0.13
40.255	-50.215	9.664	40.264	-50.2	9.648	-0.009	-0.016	0.016	0.024
42.418	-46.256	13.352	42.441	-46.215	13.265	-0.023	-0.042	0.087	0.099
45.077	-41.401	15.242	45.085	-41.385	15.126	-0.008	-0.016	0.116	0.118
47.501	-36.973	15.339	47.487	-36.998	15.142	0.014	0.025	0.197	0.199
50.218	-32.014	13.584	50.146	-32.143	13.309	0.072	0.13	0.275	0.313
52.481	-27.883	9.954	52.344	-28.132	9.7	0.137	0.249	0.254	0.381
53.911	-25.275	4.823	53.82	-25.44	4.748	0.09	0.164	0.075	0.202
61.039	-33.446	4.813	60.874	-33.51	4.742	0.166	0.064	0.071	0.191
58.093	-34.592	9.758	58.02	-34.62	9.688	0.073	0.028	0.07	0.105
53.898	-36.224	13.56	53.765	-36.274	13.298	0.132	0.051	0.262	0.298
48.633	-38.276	15.268	48.615	-38.283	15.138	0.018	0.007	0.13	0.131
48.688	-40.007	15.366	48.655	-39.995	15.132	0.033	-0.012	0.234	0.237
53.997	-41.804	13.503	53.882	-41.764	13.28	0.114	-0.04	0.223	0.254
58.308	-43.264	9.777	58.192	-43.224	9.669	0.116	-0.04	0.109	0.164
61.238	-44.26	4.801	61.078	-44.205	4.733	0.161	-0.055	0.068	0.183
54.523	-52.743	4.833	54.383	-52.511	4.725	0.14	-0.232	0.108	0.291
52.837	-49.969	9.709	52.805	-49.915	9.653	0.033	-0.054	0.056	0.084

50.485	-46.101	13.405	50.446	-46.037	13.267	0.039	-0.064	0.138	0.157
47.596	-41.35	15.306	47.583	-41.326	15.127	0.014	-0.023	0.178	0.18
45.903	-41.688	15.292	45.907	-41.663	15.125	-0.004	-0.025	0.166	0.168
45.072	-47.119	13.287	45.074	-47.106	13.263	-0.002	-0.013	0.024	0.028
44.389	-51.591	9.647	44.389	-51.591	9.647	0	0	0	0.001
43.928	-54.627	4.733	43.933	-54.591	4.718	-0.005	-0.035	0.014	0.039
53.904	-25.286	4.82	53.819	-25.44	4.749	0.084	0.153	0.07	0.189
52.471	-27.898	9.938	52.343	-28.132	9.7	0.128	0.233	0.238	0.357
50.206	-32.031	13.548	50.144	-32.144	13.309	0.062	0.113	0.239	0.271
47.499	-36.974	15.325	47.486	-36.998	15.142	0.013	0.023	0.183	0.185
32.062	-49.839	0.384	32.102	-49.81	0.29	-0.04	-0.03	0.095	0.107
36.497	-54.222	0.301	36.521	-54.187	0.2	-0.023	-0.036	0.101	0.109
45.14	-56.61	0.588	45.145	-56.536	0.487	-0.005	-0.074	0.101	0.125
54.692	-54.431	0.912	54.583	-54.232	0.664	0.11	-0.2	0.248	0.337
61.2	-48.063	1.055	60.96	-47.919	0.79	0.24	-0.144	0.265	0.386
63.638	-39.486	1.081	63.355	-39.481	0.823	0.283	-0.006	0.258	0.383
5.559	29.882	-10.565	5.559	29.526	-10.672	0	0.356	0.107	0.372
2.189	29.924	-10.552	2.189	29.526	-10.672	0	0.398	0.119	0.415
2.186	26.789	-0.024	2.186	26.37	-0.15	0	0.42	0.126	0.438
-1.177	29.904	-10.562	-1.177	29.527	-10.675	0	0.377	0.113	0.394
5.552	20.016	-12.807	5.552	19.963	-12.79	0	0.054	-0.016	-0.056
2.184	22.975	-2.226	2.184	23.119	-2.27	0	-0.144	0.043	0.15
2.185	19.832	-12.752	2.185	19.962	-12.791	0	-0.13	0.039	0.136
-1.183	20.047	-12.817	-1.183	19.962	-12.791	0	0.085	-0.026	-0.089
8.203	27.537	-10.647	8.094	27.537	-10.69	0.108	0	0.043	0.117
8.265	25.012	-10.621	8.094	25.012	-10.689	0.171	0	0.068	0.184
3.902	25.023	-0.158	3.884	25.023	-0.165	0.018	0	0.007	0.019
8.121	22.487	-10.676	8.093	22.487	-10.687	0.028	0	0.011	0.03
-4.833	27.547	-12.686	-4.652	27.547	-12.759	-0.181	0	0.072	0.195
-0.602	25.024	-2.168	-0.441	25.024	-2.232	-0.16	0	0.064	0.173
-4.931	25.02	-12.645	-4.651	25.02	-12.757	-0.28	0	0.112	0.302
-4.739	22.495	-12.72	-4.65	22.495	-12.755	-0.089	0	0.035	0.096
-9.029	4.949	-2.264	-9.226	5.057	-2.264	0.197	-0.108	0	0.225
-8.984	4.934	9.521	-9.222	5.064	9.521	0.238	-0.131	0	0.271
-0.608	10.267	9.519	-0.622	10.502	9.519	0.014	-0.236	0	0.236
-0.611	10.338	-2.266	-0.621	10.503	-2.266	0.01	-0.164	0	0.165
8.544	6.132	-2.263	8.547	6.135	-2.263	-0.003	-0.002	0	0.004
8.548	6.149	9.522	8.541	6.144	9.522	0.008	0.005	0	-0.009
10.03	-3.293	9.527	9.996	-3.282	9.527	0.034	-0.011	0	-0.035
10.161	-3.341	0.688	9.994	-3.286	0.688	0.166	-0.055	0	-0.175
0.022	-10.547	0.692	0.022	-10.521	0.692	0	-0.027	0	-0.027

0.019	-10.399	9.53	0.02	-10.521	9.53	0	0.122	0	0.122
-9.835	-3.23	9.524	-9.996	-3.283	9.524	0.161	0.053	0	0.169
-10.04	-3.302	0.687	-9.994	-3.287	0.687	-0.046	-0.015	0	-0.048
10.888	-10.36	3.643	10.671	-10.153	3.643	0.217	-0.207	0	0.3
-11.108	-9.521	3.634	-11.183	-9.586	3.634	0.076	0.065	0	-0.1
-14.627	1.912	0.679	-14.605	1.909	0.679	-0.023	0.003	0	0.023
-8.365	12.203	3.619	-8.328	12.149	3.619	-0.037	0.054	0	0.066
3.522	14.444	0.675	3.49	14.31	0.675	0.033	0.134	0	0.138
12.937	6.961	3.63	12.971	6.979	3.63	-0.034	-0.018	0	-0.038
1.896	2.125	-16.703	1.896	2.125	-16.833	0	0	0.13	0.13
-3.778	3.801	-17.019	-3.778	3.801	-16.833	0	0	-0.186	-0.186
-3.866	-4.132	-16.981	-3.866	-4.132	-16.833	0	0	-0.148	-0.148
3.706	-3.992	-16.952	3.706	-3.992	-16.833	0	0	-0.119	-0.119
-0.336	0.167	-20.944	-0.336	0.167	-21.042	0	0	0.097	0.097
-9.372	-8.53	12.839	-9.372	-8.53	12.625	0	0	0.214	0.214
-12.003	3.531	12.92	-12.003	3.531	12.625	0	0	0.295	0.295
-0.921	12.002	12.847	-0.921	12.002	12.625	0	0	0.222	0.222
11.232	4.923	12.863	11.232	4.923	12.625	0	0	0.238	0.238
10.57	-7.017	12.816	10.57	-7.017	12.625	0	0	0.191	0.191
0.427	-12.814	12.815	0.427	-12.814	12.625	0	0	0.19	0.19
-0.454	-14.777	6.729	-0.452	-14.722	6.729	-0.002	-0.055	0	0.055
7.284	-46.786	6.613	6.972	-46.786	6.613	0.312	0	0	0.312
7.281	-36.778	6.605	6.972	-36.778	6.605	0.309	0	0	0.309
7.208	-26.77	6.598	6.972	-26.77	6.598	0.236	0	0	0.236
7.133	-16.763	6.592	6.972	-16.763	6.592	0.161	0	0	0.161
4.644	-17.724	6.589	4.447	-17.724	6.589	0.197	0	0	-0.197
4.64	-27.446	6.598	4.447	-27.446	6.598	0.193	0	0	-0.193
4.587	-37.168	6.604	4.447	-37.168	6.604	0.14	0	0	-0.14
4.668	-46.89	6.611	4.447	-46.89	6.611	0.221	0	0	-0.221
-4.294	-46.896	9.557	-3.97	-46.896	9.557	-0.324	0	0	-0.324
-4.191	-37.21	9.549	-3.97	-37.21	9.549	-0.221	0	0	-0.221
-4.257	-27.526	9.543	-3.97	-27.526	9.543	-0.287	0	0	-0.287
-4.091	-17.84	9.535	-3.97	-17.84	9.535	-0.121	0	0	-0.121
-8.116	-16.103	3.639	-8.178	-16.103	3.639	0.062	0	0	-0.062
-8.444	-26.303	3.647	-8.178	-26.303	3.647	-0.266	0	0	0.266
-8.567	-36.503	3.655	-8.178	-36.503	3.655	-0.389	0	0	0.389
-8.643	-46.703	3.662	-8.178	-46.703	3.662	-0.465	0	0	0.465
-6.097	-50.772	7.064	-6.097	-50.5	7.064	0	-0.272	0	0.272
5.654	-50.401	10.3	5.654	-50.5	10.3	0	0.099	0	-0.099
5.651	-46.548	12.905	5.651	-46.548	12.625	0	0	0.28	0.28
5.679	-37.503	12.874	5.679	-37.503	12.625	0	0	0.249	0.249

5.595	-28.46	12.816	5.595	-28.46	12.625	0	0	0.191	0.191
5.834	-17.491	12.841	5.834	-17.491	12.625	0	0	0.216	0.216
-6.157	-16.924	12.853	-6.157	-16.924	12.625	0	0	0.228	0.228
-6.286	-27.326	12.827	-6.286	-27.326	12.625	0	0	0.202	0.202
-6.316	-36.145	12.782	-6.316	-36.145	12.625	0	0	0.157	0.157
-5.867	-47.898	12.82	-5.867	-47.898	12.625	0	0	0.195	0.195
62.939	-85.844	-0.025	62.939	-85.844	0	0	0	-0.025	-0.025
51.51	-86.204	-0.102	51.51	-86.204	0	0	0	-0.102	-0.102
30.764	-85.707	-0.134	30.764	-85.707	0	0	0	-0.134	-0.134
26.786	-77.985	-0.051	26.786	-77.985	0	0	0	-0.051	-0.051
39.971	-79.721	0.022	39.971	-79.721	0	0	0	0.022	0.022
56.408	-76.347	-0.104	56.408	-76.347	0	0	0	-0.104	-0.104
61.065	-67.051	-0.115	61.065	-67.051	0	0	0	-0.115	-0.115
47.072	-70.291	-0.171	47.072	-70.291	0	0	0	-0.171	-0.171
37.556	-65.887	-0.151	37.556	-65.887	0	0	0	-0.151	-0.151
23.907	-65.548	-0.006	23.907	-65.548	0	0	0	-0.006	-0.006
19.955	-53.441	-0.029	19.955	-53.441	0	0	0	-0.029	-0.029
15.194	-46.311	-0.057	15.194	-46.311	0	0	0	-0.057	-0.057
23.605	-45.572	-0.026	23.605	-45.572	0	0	0	-0.026	-0.026
14.852	-35.377	-0.11	14.852	-35.377	0	0	0	-0.11	-0.11
15.726	-25.417	-0.202	15.726	-25.417	0	0	0	-0.202	-0.202
25.634	-28.363	-0.163	25.634	-28.363	0	0	0	-0.163	-0.163
33.623	-23.376	-0.13	33.623	-23.376	0	0	0	-0.13	-0.13
61.715	-24.546	-0.151	61.715	-24.546	0	0	0	-0.151	-0.151
68.083	-35.071	-0.025	68.083	-35.071	0	0	0	-0.025	-0.025
65.263	-55.041	-0.089	65.263	-55.041	0	0	0	-0.089	-0.089
68.963	-6.622	-0.091	68.963	-6.622	0	0	0	-0.091	-0.091
66.157	18.378	-0.116	66.157	18.378	0	0	0	-0.116	-0.116
52.25	18.967	-0.27	52.25	18.967	0	0	0	-0.27	-0.27
38.374	18.73	-0.244	38.374	18.73	0	0	0	-0.244	-0.244
25.02	19.064	-0.14	25.02	19.064	0	0	0	-0.14	-0.14
27.131	28.522	-0.064	27.131	28.522	0	0	0	-0.064	-0.064
34.27	26.854	-0.104	34.27	26.854	0	0	0	-0.104	-0.104
46.012	25.908	-0.184	46.012	25.908	0	0	0	-0.184	-0.184
45.703	34.449	-0.065	45.703	34.449	0	0	0	-0.065	-0.065
29.734	39.376	0.02	29.734	39.376	0	0	0	0.02	0.02
17.38	42.23	-0.07	17.38	42.23	0	0	0	-0.07	-0.07
7.137	39.368	-0.058	7.137	39.368	0	0	0	-0.058	-0.058
10.315	49.417	-0.021	10.315	49.417	0	0	0	-0.021	-0.021
23.005	52.369	-0.048	23.005	52.369	0	0	0	-0.048	-0.048
43.309	55.601	-0.189	43.309	55.601	0	0	0	-0.189	-0.189

66.5	54.25	-0.256	66.5	54.25	0	0	0	-0.256	-0.256
67.075	38.273	-0.054	67.075	38.273	0	0	0	-0.054	-0.054
-12.147	40.857	0.072	-12.147	40.857	0	0	0	0.072	0.072
-22.742	17.572	0.15	-22.742	17.572	0	0	0	0.15	0.15
-24.034	30.765	0.216	-24.034	30.765	0	0	0	0.216	0.216
-31.216	26.085	0.195	-31.216	26.085	0	0	0	0.195	0.195
-42.946	26.756	0.056	-42.946	26.756	0	0	0	0.056	0.056
-50.434	30.616	0.027	-50.434	30.616	0	0	0	0.027	0.027
-40.377	46.158	0.179	-40.377	46.158	0	0	0	0.179	0.179
-47.492	54.721	0.025	-47.492	54.721	0	0	0	0.025	0.025
-75.504	53.961	0.005	-75.504	53.961	0	0	0	0.005	0.005
-75.734	37.679	0.035	-75.734	37.679	0	0	0	0.035	0.035
-74.534	19.519	-0.136	-74.534	19.519	0	0	0	-0.136	-0.136
-57.051	25.407	-0.065	-57.051	25.407	0	0	0	-0.065	-0.065
-66.102	12.108	-0.142	-66.102	12.108	0	0	0	-0.142	-0.142
-68.625	-0.949	-0.133	-68.625	-0.949	0	0	0	-0.133	-0.133
-76.988	-10.635	-0.205	-76.988	-10.635	0	0	0	-0.205	-0.205
-76.865	-29.111	-0.269	-76.865	-29.111	0	0	0	-0.269	-0.269
-62.595	-24.721	-0.24	-62.595	-24.721	0	0	0	-0.24	-0.24
-49.906	-21.77	-0.219	-49.906	-21.77	0	0	0	-0.219	-0.219
-35.582	-26.481	-0.088	-35.582	-26.481	0	0	0	-0.088	-0.088
-22.819	-18.01	0.017	-22.819	-18.01	0	0	0	0.017	0.017
-27.848	-36.951	-0.056	-27.848	-36.951	0	0	0	-0.056	-0.056
-13.731	-51.044	-0.106	-13.731	-51.044	0	0	0	-0.106	-0.106
-5.239	-60.106	-0.185	-5.239	-60.106	0	0	0	-0.185	-0.185
-6.483	-70.908	-0.154	-6.483	-70.908	0	0	0	-0.154	-0.154
-7.841	-86.126	-0.204	-7.841	-86.126	0	0	0	-0.204	-0.204
-27.272	-90.704	-0.303	-27.272	-90.704	0	0	0	-0.303	-0.303
-40.963	-88.451	-0.221	-40.963	-88.451	0	0	0	-0.221	-0.221
-53.714	-82.028	-0.128	-53.714	-82.028	0	0	0	-0.128	-0.128
-62.93	-90.642	-0.201	-62.93	-90.642	0	0	0	-0.201	-0.201
-77.254	-85.932	-0.076	-77.254	-85.932	0	0	0	-0.076	-0.076
-75.58	-64.36	-0.152	-75.58	-64.36	0	0	0	-0.152	-0.152
-71.955	-44.095	-0.181	-71.955	-44.095	0	0	0	-0.181	-0.181
-65.81	-56.003	-0.2	-65.81	-56.003	0	0	0	-0.2	-0.2
-62.191	-65.796	-0.099	-62.191	-65.796	0	0	0	-0.099	-0.099
-50.469	-58.744	-0.182	-50.469	-58.744	0	0	0	-0.182	-0.182
-50.236	-72.801	-0.071	-50.236	-72.801	0	0	0	-0.071	-0.071
-14.077	-37.916	-16.903	-14.077	-37.916	-16.833	0	0	-0.07	-0.07
-14.455	-16.517	-16.988	-14.455	-16.517	-16.833	0	0	-0.154	-0.154
-13.61	16.158	-16.784	-13.61	16.158	-16.833	0	0	0.049	0.049

-13.431	29.366	-16.785	-13.431	29.366	-16.833	0	0	0.048	0.048
14.632	31.604	-16.952	14.632	31.604	-16.833	0	0	-0.118	-0.118
15.493	23.898	-16.908	15.493	23.898	-16.833	0	0	-0.075	-0.075
15.749	12.206	-16.851	15.749	12.206	-16.833	0	0	-0.018	-0.018
59.928	4.254	-17.016	59.928	4.254	-16.833	0	0	-0.183	-0.183
58.356	-10.016	-17.038	58.356	-10.016	-16.833	0	0	-0.205	-0.205
48.858	-15.301	-17.079	48.858	-15.301	-16.833	0	0	-0.246	-0.246
36.455	-9.695	-16.997	36.455	-9.695	-16.833	0	0	-0.164	-0.164
30.678	-17.715	-17.023	30.678	-17.715	-16.833	0	0	-0.19	-0.19
13.222	-15.182	-16.974	13.222	-15.182	-16.833	0	0	-0.14	-0.14
19.525	2.806	-4.176	19.525	2.806	-4.208	0	0	0.032	0.032
28.915	7.206	-4.274	28.915	7.206	-4.208	0	0	-0.066	-0.066
34.436	2.943	-4.286	34.436	2.943	-4.208	0	0	-0.077	-0.077
41.195	7.319	-4.375	41.195	7.319	-4.208	0	0	-0.166	-0.166
46.417	2.129	-4.283	46.417	2.129	-4.208	0	0	-0.075	-0.075
52.019	8.342	-4.32	52.019	8.342	-4.208	0	0	-0.112	-0.112
50.838	-3.249	0.031	50.838	-3.249	0	0	0	0.031	0.031
40.315	-3.037	-0.064	40.315	-3.037	0	0	0	-0.064	-0.064
28.623	-2.836	-0.069	28.623	-2.836	0	0	0	-0.069	-0.069
16.936	-2.019	-0.09	16.936	-2.019	0	0	0	-0.09	-0.09
18.549	-9.347	1.815	18.549	-9.347	1.683	0	0	0.131	0.131
24.71	-6.517	1.645	24.71	-6.517	1.683	0	0	-0.039	-0.039
25.815	-14.825	1.852	25.815	-14.825	1.683	0	0	0.169	0.169
18.781	-12.202	-4.25	18.781	-12.447	-4.25	0	0.245	0	-0.245
25.676	-16.373	0.138	25.676	-16.655	0.138	0	0.282	0	-0.282
32.996	-4.038	-4.317	32.996	-4.03	-4.317	0	-0.008	0	0.008
40.019	-3.994	-3.562	40.019	-4.03	-3.562	0	0.036	0	-0.036
52.641	-4.006	-4.834	52.641	-4.03	-4.834	0	0.024	0	-0.024
55.399	-0.017	-9.111	55.24	0.034	-9.111	0.159	-0.051	0	0.167
56.723	7.85	-9.862	56.527	7.85	-9.862	0.196	0	0	0.196
59.487	12.28	-0.691	59.487	12.269	-0.667	0	0.011	-0.024	-0.027
49.271	13.102	-1.462	49.271	13.081	-1.424	0	0.022	-0.037	-0.043
39.433	12.36	-1.472	39.433	12.294	-1.406	0	0.066	-0.066	-0.094

### 3D-Tol Data from CMM for SLS Magnesium Casting

MEAS X	MEAS Y	MEAS Z	CAD X	CAD Y	CAD Z	DIF X	DIF Y	DIF Z	TOT DIF
53.676	59.136	-5.626	53.676	58.917	-5.626	0	0.219	0	0.219
37.13	59.032	-5.625	37.13	58.917	-5.625	0	0.115	0	0.115
20.586	58.966	-5.626	20.586	58.917	-5.626	0	0.049	0	0.049
4.042	58.978	-5.626	4.042	58.917	-5.626	0	0.062	0	0.062

-12.504	58.999	-5.628	-12.504	58.917	-5.628	0	0.082	0	0.082
-29.049	59.034	-5.628	-29.049	58.917	-5.628	0	0.117	0	0.117
-45.593	59.111	-5.628	-45.593	58.917	-5.628	0	0.194	0	0.194
-62.137	59.156	-5.63	-62.137	58.917	-5.63	0	0.24	0	0.24
-80.083	41.034	-5.638	-79.958	41.034	-5.638	-0.124	0	0	0.124
-80.088	24.489	-5.642	-79.958	24.489	-5.642	-0.129	0	0	0.129
-80.027	7.944	-5.646	-79.958	7.944	-5.646	-0.069	0	0	0.069
-79.994	-8.6	-5.65	-79.958	-8.6	-5.65	-0.036	0	0	0.036
-79.994	-25.145	-5.655	-79.958	-25.145	-5.655	-0.036	0	0	0.036
-79.975	-41.689	-5.66	-79.958	-41.689	-5.66	-0.017	0	0	0.017
-79.94	-58.235	-5.664	-79.958	-58.235	-5.664	0.018	0	0	-0.018
-79.994	-74.779	-5.668	-79.958	-74.779	-5.668	-0.035	0	0	0.035
-62.137	-92.668	-5.674	-62.137	-92.583	-5.674	0	-0.085	0	0.085
-45.592	-92.658	-5.673	-45.592	-92.583	-5.673	0	-0.074	0	0.074
-29.047	-92.562	-5.673	-29.047	-92.583	-5.673	0	0.022	0	-0.022
-12.503	-92.611	-5.672	-12.503	-92.583	-5.672	0	-0.028	0	0.028
4.042	-92.623	-5.671	4.042	-92.583	-5.671	0	-0.04	0	0.04
20.587	-92.638	-5.67	20.587	-92.583	-5.67	0	-0.054	0	0.054
37.132	-92.599	-5.67	37.132	-92.583	-5.67	0	-0.016	0	0.016
53.677	-92.623	-5.669	53.677	-92.583	-5.669	0	-0.04	0	0.04
71.892	-74.779	-5.667	71.542	-74.779	-5.667	0.35	0	0	0.35
71.887	-58.233	-5.656	71.542	-58.233	-5.656	0.345	0	0	0.345
71.88	-41.689	-5.652	71.542	-41.689	-5.652	0.339	0	0	0.339
71.868	-25.144	-5.648	71.542	-25.144	-5.648	0.327	0	0	0.327
71.943	-8.599	-5.644	71.542	-8.599	-5.644	0.401	0	0	0.401
71.909	7.947	-5.639	71.542	7.947	-5.639	0.368	0	0	0.368
71.906	24.491	-5.634	71.542	24.491	-5.634	0.364	0	0	0.364
71.893	41.035	-5.632	71.542	41.035	-5.632	0.351	0	0	0.351
-69.882	43.723	8.523	-69.882	43.723	8.417	0	0	0.107	0.107
-64.83	43.721	8.356	-64.83	43.721	8.417	0	0	-0.061	-0.061
-64.83	48.773	8.459	-64.83	48.773	8.417	0	0	0.042	0.042
-69.881	48.774	8.582	-69.881	48.774	8.417	0	0	0.165	0.165
-67.749	46.368	8.465	-67.749	46.368	8.417	0	0	0.048	0.048
-71.7	43.726	6.988	-71.542	43.726	6.988	-0.158	0	0	0.158
-71.706	48.775	6.992	-71.542	48.775	6.992	-0.164	0	0	0.164
-69.881	50.68	6.991	-69.881	50.5	6.991	0	0.18	0	0.18
-64.831	50.687	6.991	-64.831	50.5	6.991	0	0.187	0	0.187
-64.832	42.203	6.985	-64.832	42.083	6.985	0	0.12	0	-0.12
-69.883	42.209	6.986	-69.883	42.083	6.986	0	0.126	0	-0.126
-63.2	48.774	6.986	-63.125	48.774	6.986	-0.075	0	0	-0.075
-63.271	43.724	6.986	-63.125	43.724	6.986	-0.146	0	0	-0.146

-64.832	-14.351	4.069	-64.832	-14.351	4.208	0	0	-0.139	-0.139
-69.881	-14.35	4.174	-69.881	-14.35	4.208	0	0	-0.035	-0.035
-69.881	-19.401	4.263	-69.881	-19.401	4.208	0	0	0.055	0.055
-64.83	-19.403	4.065	-64.83	-19.403	4.208	0	0	-0.143	-0.143
-68.002	-16.776	4.142	-68.002	-16.776	4.208	0	0	-0.066	-0.066
-69.882	-12.589	3.609	-69.882	-12.625	3.609	0	0.036	0	0.036
-64.83	-12.602	3.61	-64.83	-12.625	3.61	0	0.023	0	0.023
-63.1	-14.35	4.19	-63.125	-14.35	4.208	0.025	0	-0.019	0.031
-63.085	-19.401	4.179	-63.125	-19.401	4.208	0.04	0	-0.029	0.05
-64.832	-21.044	3.602	-64.832	-21.042	3.602	0	-0.002	0	0.002
-69.882	-21.051	3.604	-69.882	-21.042	3.604	0	-0.009	0	0.009
-71.737	-19.398	3.605	-71.542	-19.398	3.605	-0.196	0	0	0.196
-71.713	-14.347	3.609	-71.542	-14.347	3.609	-0.171	0	0	0.171
-64.831	-77.477	8.404	-64.831	-77.477	8.417	0	0	-0.013	-0.013
-69.882	-77.477	8.541	-69.882	-77.477	8.417	0	0	0.124	0.124
-69.879	-82.528	8.557	-69.879	-82.528	8.417	0	0	0.14	0.14
-64.829	-82.529	8.416	-64.829	-82.529	8.417	0	0	-0.001	-0.001
-69.88	-75.862	6.959	-69.88	-75.75	6.959	0	-0.112	0	-0.112
-64.83	-75.873	6.959	-64.83	-75.75	6.959	0	-0.123	0	-0.123
-63.282	-77.477	6.955	-63.125	-77.477	6.955	-0.157	0	0	-0.157
-63.25	-82.528	6.954	-63.125	-82.528	6.954	-0.125	0	0	-0.125
-64.832	-84.348	6.953	-64.832	-84.167	6.953	0	-0.181	0	0.181
-69.882	-84.303	6.954	-69.882	-84.167	6.954	0	-0.136	0	0.136
-71.699	-82.524	6.956	-71.542	-82.524	6.956	-0.157	0	0	0.157
-71.721	-77.474	6.96	-71.542	-77.474	6.96	-0.18	0	0	0.18
-2.548	43.725	4.033	-2.548	43.725	4.208	0	0	-0.175	-0.175
2.503	43.724	3.991	2.503	43.724	4.208	0	0	-0.218	-0.218
2.503	48.774	4.038	2.503	48.774	4.208	0	0	-0.171	-0.171
-2.549	48.775	4.035	-2.549	48.775	4.208	0	0	-0.173	-0.173
-0.705	46.759	4.049	-0.705	46.759	4.208	0	0	-0.16	-0.16
-4.217	43.727	2.362	-4.208	43.727	2.362	-0.008	0	0	0.008
-4.228	48.777	2.37	-4.208	48.777	2.37	-0.02	0	0	0.02
2.502	42.189	2.359	2.502	42.083	2.359	0	0.106	0	-0.106
-2.548	42.207	2.36	-2.548	42.083	2.36	0	0.124	0	-0.124
4.201	48.775	2.359	4.208	48.775	2.359	-0.007	0	0	-0.007
4.234	43.726	2.359	4.208	43.726	2.359	0.025	0	0	0.025
-2.548	50.689	2.364	-2.548	50.5	2.364	0	0.189	0	0.189
2.504	50.623	2.364	2.504	50.5	2.364	0	0.123	0	0.123
-64.911	36.284	-1.012	-64.814	36.186	-1.012	-0.098	0.098	0	-0.138
-54.226	47.023	-1.007	-54.102	46.898	-1.007	-0.125	0.125	0	-0.176
-46.857	46.982	-1.005	-46.92	46.92	-1.005	0.062	0.062	0	-0.088

-36.149	36.269	-1.008	-36.209	36.209	-1.008	0.06	0.06	0	-0.085
-40.914	29.121	-1.009	-40.969	29.066	-1.009	0.055	0.055	0	0.078
-48.129	36.191	-1.009	-48.111	36.209	-1.009	-0.018	-0.018	0	-0.025
-35.872	29.641	-1.389	-35.761	29.53	-1.389	-0.111	0.111	0	0.157
-54.19	35.084	-1.009	-54.102	34.995	-1.009	-0.089	0.089	0	0.125
-58.97	30.331	-1.007	-58.868	30.229	-1.007	-0.102	0.102	0	0.144
-65.33	29.664	-0.913	-65.351	29.642	-0.913	0.021	0.021	0	0.03
-61.418	33.52	-4.401	-61.418	33.52	-4.208	0	0	-0.193	-0.193
-56.849	38.275	-4.442	-56.849	38.275	-4.208	0	0	-0.233	-0.233
-50.353	43.677	-4.428	-50.353	43.677	-4.208	0	0	-0.22	-0.22
-44.794	38.63	-4.407	-44.794	38.63	-4.208	0	0	-0.198	-0.198
-40.118	33.823	-4.479	-40.118	33.823	-4.208	0	0	-0.271	-0.271
49.634	42.095	6.148	49.634	42.083	6.148	0	0.012	0	-0.012
42.901	42.241	6.149	42.901	42.083	6.149	0	0.158	0	-0.158
54.85	30.258	6.149	54.708	30.258	6.149	0.142	0	0	-0.142
54.811	36.994	6.153	54.708	36.994	6.153	0.102	0	0	-0.102
58.774	25.344	5.65	58.774	25.25	5.65	0	0.094	0	-0.094
63.23	30.257	6.146	63.125	30.257	6.146	0.105	0	0	0.105
63.24	37.833	6.151	63.125	37.833	6.151	0.115	0	0	0.115
63.262	45.408	6.153	63.125	45.408	6.153	0.137	0	0	0.137
58.051	50.592	6.155	58.051	50.5	6.155	0	0.092	0	0.092
50.477	50.583	6.157	50.477	50.5	6.157	0	0.083	0	0.083
42.902	50.609	6.156	42.902	50.5	6.156	0	0.109	0	0.109
38.001	46.202	5.435	37.875	46.202	5.435	0.126	0	0	-0.126
43.152	46.368	8.366	43.152	46.368	8.417	0	0	-0.051	-0.051
50.385	46.077	8.34	50.385	46.077	8.417	0	0	-0.077	-0.077
58.357	45.745	8.453	58.357	45.745	8.417	0	0	0.037	0.037
59.096	37.482	8.363	59.096	37.482	8.417	0	0	-0.054	-0.054
58.972	30.637	8.317	58.972	30.637	8.417	0	0	-0.099	-0.099
-30.927	49.061	17.085	-30.927	48.969	17.138	0	0.092	-0.053	-0.107
-30.927	46.174	12.046	-30.927	46.065	12.108	0	0.109	-0.063	-0.126
-30.926	43.314	6.996	-30.926	43.163	7.083	0	0.151	-0.087	-0.174
-30.926	40.419	1.97	-30.926	40.263	2.059	0	0.156	-0.09	-0.18
-27.137	40.394	1.985	-27.137	40.263	2.06	0	0.131	-0.075	-0.151
-27.138	43.332	6.987	-27.138	43.164	7.084	0	0.168	-0.097	-0.194
-27.138	46.235	12.012	-27.138	46.066	12.11	0	0.169	-0.098	-0.195
-27.137	49.092	17.067	-27.137	48.969	17.139	0	0.123	-0.071	-0.142
-23.35	49.092	17.066	-23.35	48.969	17.138	0	0.124	-0.071	-0.143
-23.351	46.178	12.045	-23.351	46.065	12.11	0	0.112	-0.065	-0.13
-23.351	43.283	7.014	-23.351	43.163	7.083	0	0.12	-0.069	-0.138
-23.35	40.424	1.967	-23.35	40.263	2.06	0	0.161	-0.093	-0.186

-17.039	45.647	2.067	-17.039	45.472	2.114	0	0.176	-0.047	-0.182
-17.038	47.617	9.62	-17.038	47.492	9.654	0	0.125	-0.033	-0.129
-17.039	49.584	17.173	-17.039	49.512	17.192	0	0.073	-0.019	-0.075
-11.989	49.622	17.164	-11.989	49.512	17.193	0	0.11	-0.029	-0.113
-11.989	47.636	9.615	-11.989	47.492	9.654	0	0.144	-0.039	-0.149
-11.989	45.644	2.068	-11.989	45.472	2.115	0	0.173	-0.046	-0.179
-8.206	49.574	7.783	-8.178	49.574	7.783	-0.028	0	0	-0.028
-30.928	50.946	15.342	-30.928	50.898	15.329	0	0.048	0.013	0.049
-30.926	52.446	9.684	-30.926	52.413	9.675	0	0.033	0.009	0.034
-30.927	54.002	4.044	-30.927	53.927	4.024	0	0.075	0.02	0.078
-24.191	54.014	4.049	-24.191	53.927	4.025	0	0.087	0.023	0.09
-24.192	52.429	9.681	-24.192	52.413	9.676	0	0.016	0.004	0.017
-24.192	50.951	15.345	-24.192	50.897	15.331	0	0.054	0.014	0.056
-17.459	50.937	15.34	-17.459	50.898	15.329	0	0.039	0.011	0.041
-17.46	52.452	9.687	-17.46	52.412	9.677	0	0.039	0.011	0.041
-17.459	53.956	4.032	-17.459	53.927	4.024	0	0.03	0.008	0.031
-10.725	53.976	4.038	-10.725	53.927	4.025	0	0.049	0.013	0.051
-10.725	52.414	9.677	-10.725	52.412	9.676	0	0.002	0.001	0.002
-10.725	50.941	15.341	-10.725	50.898	15.329	0	0.043	0.012	0.044
-33.472	48.919	9.93	-33.428	48.919	9.93	-0.044	0	0	0.044
5.13	-63.169	19.05	5.106	-63.169	19.056	0.023	0	-0.006	-0.024
3.309	-63.167	11.96	3.212	-63.167	11.986	0.098	0	-0.026	-0.101
1.375	-63.165	4.905	1.318	-63.165	4.92	0.056	0	-0.015	-0.058
1.365	-69.901	4.905	1.318	-69.901	4.918	0.047	0	-0.013	-0.049
3.266	-69.902	11.972	3.212	-69.902	11.987	0.054	0	-0.014	-0.056
5.105	-69.904	19.055	5.106	-69.904	19.055	-0.001	0	0	0.001
5.11	-76.637	19.051	5.105	-76.637	19.052	0.005	0	-0.001	-0.005
3.27	-76.635	11.967	3.211	-76.635	11.983	0.059	0	-0.016	-0.061
1.363	-76.632	4.901	1.317	-76.632	4.913	0.047	0	-0.013	-0.048
1.343	-83.368	4.906	1.317	-83.368	4.913	0.026	0	-0.007	-0.027
3.249	-83.368	11.972	3.211	-83.368	11.983	0.038	0	-0.01	-0.039
5.127	-83.37	19.046	5.105	-83.37	19.052	0.022	0	-0.006	-0.023
7.437	-85.926	10.584	7.437	-85.85	10.584	0	-0.076	0	0.076
7.54	-83.371	21.367	7.568	-83.371	21.383	-0.029	0	-0.017	-0.033
13.033	-83.369	11.97	13.011	-83.369	11.957	0.023	0	0.013	0.026
18.462	-83.366	2.541	18.451	-83.366	2.535	0.011	0	0.007	0.013
18.435	-75.791	2.528	18.449	-75.791	2.537	-0.015	0	-0.009	-0.017
12.983	-75.795	11.946	13.008	-75.795	11.961	-0.025	0	-0.015	-0.029
7.518	-75.798	21.357	7.567	-75.798	21.385	-0.049	0	-0.028	-0.057
6.85	-69.483	21.414	6.885	-69.483	21.423	-0.035	0	-0.009	-0.036
9.388	-69.482	11.991	9.41	-69.482	11.997	-0.022	0	-0.006	-0.023

11.899	-69.48	2.567	11.935	-69.48	2.576	-0.036	0	-0.01	-0.037
11.887	-64.429	2.565	11.934	-64.429	2.578	-0.047	0	-0.013	-0.049
9.375	-64.433	11.99	9.41	-64.433	12	-0.035	0	-0.009	-0.036
6.837	-64.435	21.412	6.884	-64.435	21.425	-0.047	0	-0.013	-0.049
6.421	-60.624	11.343	6.421	-60.6	11.343	0	-0.024	0	-0.024
-30.572	-50.235	-5.409	-30.565	-50.344	-5.298	-0.007	0.11	-0.111	-0.156
-30.276	-54.871	-8.06	-30.267	-55.006	-7.798	-0.009	0.135	-0.262	-0.295
-30.054	-58.407	-11.481	-30.049	-58.48	-11.442	-0.005	0.073	-0.039	-0.083
-29.866	-61.346	-15.903	-29.86	-61.439	-15.78	-0.006	0.094	-0.123	-0.155
-33.949	-63.372	-15.837	-33.905	-63.411	-15.763	-0.043	0.038	-0.075	-0.094
-36.122	-61.428	-11.445	-36.103	-61.444	-11.431	-0.019	0.017	-0.013	-0.029
-38.752	-59.068	-7.913	-38.705	-59.11	-7.788	-0.048	0.043	-0.125	-0.14
-42.233	-55.949	-5.344	-42.184	-55.993	-5.278	-0.049	0.044	-0.066	-0.093
-46.497	-68.159	-5.247	-46.506	-68.159	-5.256	0.008	0	0.008	0.012
-41.886	-67.945	-7.869	-41.839	-67.943	-7.777	-0.047	-0.002	-0.092	-0.103
-38.235	-67.778	-11.367	-38.332	-67.783	-11.419	0.097	0.005	0.052	0.111
-35.432	-67.648	-15.783	-35.403	-67.646	-15.745	-0.029	-0.002	-0.038	-0.048
-33.558	-71.772	-15.832	-33.506	-71.716	-15.735	-0.052	-0.056	-0.097	-0.124
-35.483	-73.839	-11.4	-35.498	-73.855	-11.412	0.016	0.017	0.012	0.026
-37.943	-76.491	-7.915	-37.893	-76.437	-7.77	-0.05	-0.054	-0.145	-0.163
-41.093	-79.888	-5.282	-41.067	-79.86	-5.245	-0.026	-0.028	-0.037	-0.053
-29.681	-67.419	-17.385	-29.741	-67.442	-16.875	0.06	0.023	-0.51	-0.514
-26.561	-62.026	-15.976	-26.631	-62.154	-15.785	0.07	0.128	-0.191	-0.24
-25.156	-59.454	-11.497	-25.205	-59.545	-11.442	0.05	0.092	-0.056	-0.118
-23.47	-56.375	-8.066	-23.537	-56.495	-7.8	0.068	0.12	-0.266	-0.299
-21.214	-52.243	-5.488	-21.3	-52.4	-5.307	0.086	0.156	-0.181	-0.254
-12.946	-62.523	-5.478	-13.115	-62.572	-5.301	0.169	0.049	-0.178	-0.25
-17.436	-63.841	-8.112	-17.592	-63.886	-7.797	0.156	0.045	-0.315	-0.355
-20.758	-64.817	-11.539	-20.934	-64.868	-11.441	0.176	0.051	-0.098	-0.207
-23.581	-65.641	-16.059	-23.784	-65.699	-15.782	0.203	0.059	-0.277	-0.348
-24.121	-70.306	-15.998	-24.279	-70.218	-15.764	0.158	-0.088	-0.234	-0.296
-21.547	-71.711	-11.515	-21.688	-71.633	-11.428	0.141	-0.078	-0.086	-0.183
-18.515	-73.36	-8.008	-18.614	-73.305	-7.785	0.1	-0.055	-0.223	-0.25
-14.395	-75.618	-5.429	-14.525	-75.546	-5.281	0.13	-0.072	-0.148	-0.21
-24.654	-83.83	-5.377	-24.687	-83.716	-5.26	0.033	-0.114	-0.117	-0.166
-25.98	-79.306	-7.907	-25.999	-79.241	-7.775	0.019	-0.065	-0.132	-0.149
-26.971	-75.939	-11.455	-26.991	-75.871	-11.417	0.02	-0.068	-0.038	-0.081
-27.78	-73.182	-15.915	-27.816	-73.054	-15.746	0.037	-0.127	-0.17	-0.215
-32.354	-72.634	-15.827	-32.319	-72.569	-15.734	-0.035	-0.064	-0.093	-0.118
-33.719	-75.132	-11.408	-33.721	-75.135	-11.41	0.002	0.003	0.002	0.004
-35.43	-78.264	-7.857	-35.409	-78.225	-7.769	-0.021	-0.039	-0.088	-0.098

-37.618	-82.27	-5.178	-37.649	-82.326	-5.239	0.03	0.055	0.062	0.088
-25.44	-86.358	-0.489	-25.437	-86.37	-0.506	-0.003	0.013	0.018	0.022
-12.978	-77.291	-0.676	-12.978	-77.291	-0.676	0	0	0	0
-10.946	-61.771	-0.711	-10.996	-61.786	-0.654	0.05	0.015	-0.057	-0.077
-15.994	-53.436	-0.711	-16.036	-53.479	-0.644	0.042	0.043	-0.068	-0.091
-25.791	-48.16	-0.601	-25.803	-48.227	-0.51	0.013	0.067	-0.091	-0.113
-47.473	-37.892	19.019	-47.297	-37.81	19.131	-0.176	-0.082	-0.112	-0.224
-44.213	-36.354	12.685	-44.001	-36.255	12.819	-0.211	-0.099	-0.135	-0.269
-40.928	-34.793	6.366	-40.709	-34.69	6.506	-0.219	-0.103	-0.14	-0.279
-40.06	-41.305	6.379	-39.865	-41.343	6.494	-0.195	0.037	-0.115	-0.229
-43.618	-40.636	12.709	-43.449	-40.669	12.809	-0.17	0.033	-0.1	-0.2
-47.234	-39.953	18.999	-47.029	-39.994	19.12	-0.204	0.041	-0.12	-0.24
-48.164	-41.829	19.044	-48.093	-41.906	19.105	-0.071	0.077	-0.061	-0.122
-45.659	-44.486	12.736	-45.592	-44.558	12.792	-0.067	0.072	-0.057	-0.114
-43.172	-47.123	6.415	-43.092	-47.208	6.482	-0.08	0.085	-0.067	-0.134
-49.144	-50.008	6.444	-49.138	-50.056	6.471	-0.006	0.048	-0.028	-0.056
-49.611	-46.404	12.758	-49.606	-46.443	12.781	-0.005	0.04	-0.023	-0.046
-50.077	-42.765	19.055	-50.069	-42.829	19.092	-0.008	0.064	-0.037	-0.074
-52.221	-42.45	19.106	-52.206	-42.422	19.088	-0.015	-0.028	0.019	0.037
-53.947	-45.611	12.771	-53.952	-45.62	12.777	0.005	0.009	-0.006	-0.012
-55.713	-48.842	6.481	-55.7	-48.818	6.465	-0.013	-0.024	0.016	0.031
-51.784	-39.931	22.917	-51.728	-39.903	22.881	-0.057	-0.028	0.036	0.073
-57.054	-42.432	12.82	-56.995	-42.404	12.782	-0.059	-0.028	0.038	0.076
-62.366	-44.951	2.747	-62.264	-44.902	2.681	-0.102	-0.049	0.065	0.131
-63.37	-36.922	2.733	-63.306	-36.934	2.695	-0.064	0.012	0.038	0.076
-57.612	-38.005	12.815	-57.575	-38.012	12.794	-0.036	0.007	0.021	0.043
-51.841	-39.08	22.894	-51.842	-39.08	22.895	0.001	0	-0.001	-0.001
-51.433	-38.354	22.895	-51.449	-38.337	22.908	0.017	-0.017	-0.014	-0.027
-55.456	-34.115	12.799	-55.464	-34.106	12.806	0.008	-0.008	-0.007	-0.014
-59.481	-29.848	2.723	-59.464	-29.866	2.709	-0.017	0.018	0.014	0.028
-52.188	-26.43	2.703	-52.192	-26.402	2.719	0.004	-0.028	-0.016	-0.032
-51.424	-32.333	12.733	-51.444	-32.185	12.819	0.02	-0.148	-0.086	-0.172
-50.676	-38.075	22.857	-50.691	-37.968	22.919	0.015	-0.107	-0.062	-0.124
-49.932	-38.259	22.829	-49.855	-38.12	22.921	-0.077	-0.139	-0.092	-0.184
-47.179	-33.219	12.681	-47.06	-33.004	12.823	-0.118	-0.215	-0.142	-0.284
-44.347	-28.037	2.627	-44.265	-27.887	2.725	-0.082	-0.15	-0.099	-0.197
-46.426	4.023	25.139	-46.313	3.918	25.293	-0.113	0.105	-0.154	-0.218
-50.263	7.655	27.317	-50.31	7.699	27.536	0.047	-0.044	-0.219	-0.228
-53.651	10.855	22.046	-53.71	10.911	22.082	0.06	-0.056	-0.037	-0.09
-56.497	13.547	8.526	-56.443	13.496	8.513	-0.054	0.051	0.014	0.075
-61.798	-1.642	8.515	-61.724	-1.636	8.501	-0.075	-0.006	0.014	0.076

-57.936	-1.331	22.049	-57.979	-1.334	22.068	0.043	0.004	-0.019	-0.047
-53.296	-0.957	27.374	-53.343	-0.961	27.526	0.047	0.004	-0.152	-0.159
-48.073	-0.536	25.081	-47.844	-0.515	25.311	-0.229	-0.021	-0.23	-0.326
-45.727	-4.794	25.1	-45.591	-4.616	25.325	-0.136	-0.179	-0.225	-0.318
-48.886	-8.927	27.22	-48.943	-9.001	27.521	0.057	0.075	-0.301	-0.315
-51.729	-12.647	22.032	-51.76	-12.688	22.055	0.031	0.041	-0.023	-0.056
-54.057	-15.692	8.499	-54.039	-15.669	8.493	-0.018	-0.023	0.005	0.03
-38.479	-19.325	8.488	-38.469	-19.375	8.497	-0.009	0.049	-0.009	-0.051
-39.198	-15.5	21.979	-39.164	-15.685	22.063	-0.034	0.185	-0.084	-0.206
-40.044	-11.019	27.189	-40.025	-11.121	27.523	-0.019	0.102	-0.334	-0.35
-41.013	-5.891	25.119	-41.049	-5.696	25.317	0.035	-0.195	-0.198	-0.28
-40.352	19.589	8.514	-40.349	19.628	8.521	-0.003	-0.039	-0.007	-0.04
-40.7	15.695	22.018	-40.684	15.876	22.099	-0.016	-0.181	-0.081	-0.199
-41.113	11.078	27.154	-41.103	11.19	27.546	-0.01	-0.112	-0.392	-0.408
-41.582	5.856	25.147	-41.593	5.727	25.276	0.011	0.129	-0.129	-0.182
-38.513	4.665	25.147	-38.591	4.563	25.274	0.078	0.102	-0.127	-0.18
-35.333	8.838	27.156	-35.265	8.926	27.546	-0.068	-0.089	-0.39	-0.406
-32.581	12.452	21.977	-32.415	12.67	22.1	-0.166	-0.218	-0.123	-0.3
-30.211	15.561	8.496	-30.131	15.666	8.521	-0.08	-0.104	-0.024	-0.133
-23.724	6.82	8.493	-23.611	6.862	8.515	-0.113	-0.042	-0.022	-0.123
-27.423	5.435	21.961	-27.138	5.54	22.097	-0.284	-0.105	-0.136	-0.332
-31.642	3.861	27.163	-31.538	3.899	27.543	-0.103	-0.038	-0.381	-0.396
-36.605	1.999	25.199	-36.68	1.971	25.279	0.075	0.027	-0.08	-0.113
-36.351	-1.25	25.186	-36.453	-1.228	25.29	0.102	-0.022	-0.104	-0.147
-31.169	-2.321	27.169	-31.062	-2.344	27.536	-0.107	0.023	-0.367	-0.383
-26.783	-3.23	21.948	-26.483	-3.293	22.085	-0.3	0.063	-0.137	-0.336
-22.935	-4.028	8.482	-22.798	-4.057	8.508	-0.136	0.029	-0.026	-0.142
-28.019	-13.629	8.479	-27.93	-13.715	8.502	-0.088	0.086	-0.023	-0.125
-30.818	-10.935	21.961	-30.638	-11.109	22.072	-0.179	0.174	-0.112	-0.274
-34.085	-7.783	27.109	-33.993	-7.872	27.53	-0.092	0.089	-0.421	-0.44
-37.862	-4.157	25.159	-37.967	-4.054	25.305	0.105	-0.103	-0.147	-0.208
-42.164	5.875	25.153	-42.163	5.749	25.277	-0.002	0.126	-0.125	-0.177
-42.209	11.128	27.177	-42.211	11.234	27.546	0.001	-0.106	-0.368	-0.383
-42.252	15.77	22.021	-42.254	15.938	22.096	0.002	-0.168	-0.075	-0.184
-42.288	19.685	8.517	-42.288	19.704	8.521	0	-0.018	-0.003	-0.018
-40.703	1.482	20.339	-40.711	1.474	20.346	0.008	0.008	-0.007	-0.013
-45.255	0.212	21.692	-45.055	0.199	21.829	-0.2	0.013	-0.137	-0.243
-40.696	-2.527	21.497	-40.744	-2.452	21.556	0.048	-0.075	-0.059	-0.107
45.11	-41.296	14.929	45.095	-41.323	15.135	0.015	0.027	-0.206	-0.208
42.527	-46.024	13.221	42.496	-46.081	13.343	0.031	0.057	-0.122	-0.138
40.373	-49.966	9.753	40.33	-50.045	9.834	0.043	0.079	-0.082	-0.121

38.888	-52.685	4.969	38.85	-52.754	5.002	0.038	0.069	-0.033	-0.085
31.948	-44.769	4.961	31.847	-44.809	5.006	0.101	0.04	-0.046	-0.118
34.821	-43.65	9.749	34.728	-43.687	9.841	0.093	0.037	-0.092	-0.136
38.998	-42.016	13.223	38.936	-42.04	13.347	0.061	0.024	-0.124	-0.14
44.009	-40.058	14.989	43.989	-40.066	15.137	0.02	0.008	-0.147	-0.149
43.969	-38.396	14.986	43.947	-38.389	15.14	0.022	-0.007	-0.154	-0.156
38.889	-36.685	13.189	38.803	-36.656	13.359	0.085	-0.028	-0.17	-0.192
34.679	-35.26	9.696	34.514	-35.205	9.855	0.165	-0.055	-0.159	-0.236
31.708	-34.258	4.959	31.577	-34.214	5.018	0.131	-0.044	-0.058	-0.15
38.271	-26.047	4.966	38.187	-25.91	5.034	0.084	-0.136	-0.067	-0.174
39.899	-28.715	9.711	39.806	-28.565	9.873	0.092	-0.151	-0.162	-0.24
42.205	-32.502	13.229	42.166	-32.438	13.371	0.039	-0.064	-0.142	-0.161
45.011	-37.108	14.937	44.995	-37.082	15.145	0.016	-0.026	-0.209	-0.211
46.636	-36.765	15.036	46.638	-36.75	15.148	-0.002	-0.016	-0.111	-0.113
47.449	-31.426	13.279	47.456	-31.373	13.381	-0.008	-0.053	-0.101	-0.115
48.127	-26.969	9.804	48.14	-26.883	9.884	-0.013	-0.086	-0.08	-0.119
48.589	-23.933	4.984	48.609	-23.801	5.041	-0.02	-0.132	-0.056	-0.145
38.886	-52.688	4.97	38.85	-52.754	5.002	0.036	0.066	-0.032	-0.081
40.374	-49.965	9.754	40.331	-50.044	9.836	0.043	0.079	-0.082	-0.121
42.527	-46.024	13.222	42.496	-46.08	13.343	0.031	0.057	-0.121	-0.137
45.109	-41.296	14.932	45.095	-41.323	15.135	0.014	0.027	-0.203	-0.205
47.429	-37.049	14.948	47.444	-37.024	15.149	-0.014	-0.025	-0.201	-0.203
50.029	-32.291	13.291	50.052	-32.249	13.382	-0.023	-0.042	-0.091	-0.103
52.215	-28.29	9.852	52.232	-28.26	9.883	-0.016	-0.03	-0.032	-0.047
53.708	-25.556	5.026	53.725	-25.525	5.041	-0.017	-0.031	-0.015	-0.038
60.817	-33.486	5.063	60.747	-33.513	5.032	0.07	0.027	0.032	0.081
57.862	-34.639	9.891	57.847	-34.645	9.876	0.015	0.006	0.015	0.022
53.633	-36.296	13.41	53.617	-36.302	13.377	0.016	0.006	0.033	0.038
48.531	-38.29	14.986	48.553	-38.282	15.147	-0.022	-0.008	-0.161	-0.163
48.582	-39.958	15.066	48.593	-39.961	15.142	-0.011	0.004	-0.077	-0.078
53.766	-41.704	13.416	53.74	-41.696	13.364	0.026	-0.009	0.051	0.058
58.09	-43.159	9.911	58.037	-43.141	9.86	0.053	-0.018	0.051	0.075
61.094	-44.174	5.073	60.977	-44.134	5.021	0.117	-0.04	0.052	0.134
54.377	-52.48	5.046	54.332	-52.406	5.009	0.045	-0.074	0.036	0.094
52.751	-49.807	9.895	52.724	-49.761	9.846	0.028	-0.046	0.049	0.072
50.369	-45.902	13.353	50.369	-45.902	13.351	0.001	-0.001	0.002	0.002
47.536	-41.25	15.02	47.545	-41.265	15.138	-0.009	0.015	-0.118	-0.119
45.901	-41.587	15.071	45.9	-41.596	15.135	0.002	0.01	-0.064	-0.065
45.089	-46.932	13.302	45.086	-46.955	13.344	0.003	0.023	-0.043	-0.048
44.418	-51.339	9.762	44.406	-51.42	9.837	0.013	0.082	-0.075	-0.112
43.946	-54.442	4.989	43.941	-54.475	5.003	0.005	0.032	-0.014	-0.035

53.709	-25.555	5.025		53.726	-25.525	5.04		-0.016	-0.03	-0.014		-0.037
52.215	-28.289	9.853		52.231	-28.26	9.884		-0.016	-0.029	-0.031		-0.046
50.029	-32.292	13.293		50.051	-32.251	13.383		-0.023	-0.042	-0.09		-0.102
47.43	-37.049	14.946		47.444	-37.023	15.149		-0.014	-0.025	-0.202		-0.204
32.337	-49.604	0.388		32.302	-49.631	0.452		0.035	0.027	-0.064		-0.078
36.659	-53.941	0.289		36.647	-53.96	0.328		0.012	0.019	-0.039		-0.045
45.158	-56.243	0.798		45.16	-56.213	0.769		-0.002	-0.029	0.029		0.041
54.474	-54.008	1.136		54.424	-53.918	1.063		0.05	-0.09	0.073		0.126
60.795	-47.789	1.318		60.682	-47.722	1.24		0.113	-0.067	0.078		0.152
63.144	-39.433	1.33		63.033	-39.431	1.266		0.111	-0.002	0.064		0.128
5.48	29.462	-10.263		5.48	29.408	-10.279		0	0.054	0.016		0.056
2.113	29.46	-10.263		2.113	29.408	-10.279		0	0.052	0.016		0.054
2.114	26.272	0.252		2.114	26.251	0.245		0	0.021	0.006		0.022
-1.254	29.499	-10.251		-1.254	29.408	-10.279		0	0.091	0.027		0.095
5.48	20.295	-12.466		5.48	20.079	-12.401		0	0.216	-0.065		-0.226
2.112	23.418	-1.937		2.112	23.235	-1.882		0	0.183	-0.055		-0.191
2.112	20.247	-12.454		2.112	20.079	-12.403		0	0.168	-0.051		-0.176
-1.253	20.294	-12.466		-1.253	20.079	-12.402		0	0.215	-0.064		-0.224
8.023	27.55	-10.26		7.936	27.55	-10.295		0.087	0	0.035		0.094
8.051	25.023	-10.249		7.936	25.023	-10.295		0.115	0	0.046		0.124
3.703	25.021	0.217		3.728	25.021	0.227		-0.025	0	-0.01		-0.027
8.013	22.497	-10.267		7.937	22.497	-10.297		0.076	0	0.03		0.082
-4.203	27.551	-12.539		-4.514	27.551	-12.414		0.311	0	-0.125		-0.335
-0.101	25.022	-1.975		-0.306	25.022	-1.893		0.204	0	-0.082		-0.22
-4.206	25.026	-12.537		-4.514	25.026	-12.414		0.308	0	-0.123		-0.331
-4.198	22.5	-12.541		-4.514	22.5	-12.414		0.316	0	-0.126		-0.34
-9.159	4.978	-1.859		-9.244	5.024	-1.859		0.085	-0.046	0		0.097
-9.165	4.978	9.926		-9.245	5.022	9.926		0.08	-0.044	0		0.091
-0.682	10.397	9.925		-0.688	10.498	9.925		0.007	-0.101	0		0.101
-0.685	10.465	-1.859		-0.688	10.498	-1.859		0.002	-0.033	0		0.033
8.557	6.193	-1.854		8.523	6.168	-1.854		0.034	0.024	0		-0.042
8.481	6.136	9.932		8.524	6.167	9.932		-0.043	-0.031	0		0.053
9.9	-3.271	9.926		9.99	-3.301	9.926		-0.09	0.03	0		0.095
9.932	-3.279	1.088		9.99	-3.298	1.088		-0.059	0.019	0		0.062
-0.026	-10.463	1.089		-0.026	-10.521	1.089		0	0.058	0		0.058
-0.025	-10.497	9.927		-0.025	-10.521	9.927		0	0.023	0		0.023
-9.95	-3.273	9.925		-9.994	-3.287	9.925		0.044	0.014	0		0.046
-9.97	-3.279	1.085		-9.994	-3.287	1.085		0.024	0.008	0		0.026
10.646	-10.167	4.029		10.652	-10.173	4.029		-0.006	0.006	0		-0.008
-11.211	-9.59	4.031		-11.193	-9.574	4.031		-0.018	-0.016	0		0.024
-14.643	1.89	1.089		-14.608	1.885	1.089		-0.035	0.005	0		0.035

-8.367	12.11	4.037	-8.373	12.118	4.037	0.005	-0.008	0	-0.009
3.437	14.345	1.091	3.432	14.324	1.091	0.005	0.021	0	0.022
12.964	7.009	4.034	12.957	7.005	4.034	0.007	0.004	0	0.008
1.838	1.48	-16.79	1.838	1.441	-16.833	0	0.039	0.044	0.058
-3.835	3.808	-17.17	-3.835	3.808	-16.833	0	0	-0.337	-0.337
-3.918	-4.126	-17.232	-3.918	-4.126	-16.833	0	0	-0.399	-0.399
3.657	-3.98	-17.236	3.657	-3.98	-16.833	0	0	-0.403	-0.403
-0.392	0.182	-21.659	-0.392	0.182	-21.042	0	0	-0.617	-0.617
-9.415	-8.556	12.212	-9.415	-8.556	12.625	0	0	-0.413	-0.413
-12.053	3.502	12.194	-12.053	3.502	12.625	0	0	-0.431	-0.431
-0.979	11.983	12.265	-0.979	11.983	12.625	0	0	-0.36	-0.36
11.18	4.913	12.235	11.18	4.913	12.625	0	0	-0.39	-0.39
10.528	-7.026	12.222	10.528	-7.026	12.625	0	0	-0.403	-0.403
0.389	-12.835	12.246	0.389	-12.835	12.625	0	0	-0.379	-0.379
-0.489	-14.764	7.115	-0.488	-14.721	7.115	-0.001	-0.043	0	0.043
6.998	-46.79	6.967	6.972	-46.79	6.967	0.026	0	0	0.026
6.998	-36.783	6.971	6.972	-36.783	6.971	0.026	0	0	0.026
6.947	-26.776	6.974	6.972	-26.776	6.974	-0.025	0	0	-0.025
6.97	-16.769	6.977	6.972	-16.769	6.977	-0.002	0	0	-0.002
4.397	-17.727	6.976	4.447	-17.727	6.976	-0.05	0	0	0.05
4.422	-27.451	6.973	4.447	-27.451	6.973	-0.025	0	0	0.025
4.36	-37.174	6.972	4.447	-37.174	6.972	-0.087	0	0	0.087
4.401	-46.896	6.968	4.447	-46.896	6.968	-0.046	0	0	0.046
-3.933	-46.913	9.914	-3.97	-46.913	9.914	0.036	0	0	0.036
-3.973	-37.228	9.916	-3.97	-37.228	9.916	-0.003	0	0	-0.003
-3.947	-27.543	9.919	-3.97	-27.543	9.919	0.022	0	0	0.022
-3.962	-17.858	9.922	-3.97	-17.858	9.922	0.008	0	0	0.008
-8.221	-16.115	4.03	-8.178	-16.115	4.03	-0.043	0	0	0.043
-8.203	-26.316	4.027	-8.178	-26.316	4.027	-0.025	0	0	0.025
-8.199	-36.516	4.024	-8.178	-36.516	4.024	-0.021	0	0	0.021
-8.203	-46.716	4.022	-8.178	-46.716	4.022	-0.025	0	0	0.025
-6.107	-50.53	7.416	-6.107	-50.5	7.416	0	-0.03	0	0.03
5.644	-50.523	10.65	5.644	-50.5	10.65	0	-0.023	0	0.023
5.64	-46.56	12.348	5.64	-46.56	12.625	0	0	-0.277	-0.277
5.664	-37.517	12.272	5.664	-37.517	12.625	0	0	-0.353	-0.353
4.725	-28.473	12.787	4.447	-28.473	12.625	0.278	0	0.162	0.322
6.666	-17.505	12.788	6.972	-17.505	12.625	-0.306	0	0.163	0.347
-6.19	-16.948	12.252	-6.19	-16.948	12.625	0	0	-0.373	-0.373
-6.311	-27.351	12.173	-6.311	-27.351	12.625	0	0	-0.452	-0.452
-6.335	-36.17	12.226	-6.335	-36.17	12.625	0	0	-0.399	-0.399
-5.876	-47.924	12.281	-5.876	-47.924	12.625	0	0	-0.344	-0.344

62.959	-85.798	0.411	62.959	-85.798	0	0	0	0.411	0.411
51.531	-86.168	0.33	51.531	-86.168	0	0	0	0.33	0.33
30.785	-85.688	0.217	30.785	-85.688	0	0	0	0.217	0.217
26.8	-77.969	0.1	26.8	-77.969	0	0	0	0.1	0.1
39.988	-79.696	0.123	39.988	-79.696	0	0	0	0.123	0.123
56.422	-76.305	0.211	56.422	-76.305	0	0	0	0.211	0.211
61.072	-67.007	0.203	61.072	-67.007	0	0	0	0.203	0.203
47.079	-70.259	0.214	47.079	-70.259	0	0	0	0.214	0.214
37.561	-65.862	0.165	37.561	-65.862	0	0	0	0.165	0.165
23.912	-65.534	0.042	23.912	-65.534	0	0	0	0.042	0.042
19.95	-53.433	-0.016	19.95	-53.433	0	0	0	-0.016	-0.016
15.182	-46.306	-0.125	15.182	-46.306	0	0	0	-0.125	-0.125
23.592	-45.559	-0.057	23.592	-45.559	0	0	0	-0.057	-0.057
14.831	-35.37	-0.195	14.831	-35.37	0	0	0	-0.195	-0.195
15.695	-25.41	-0.16	15.695	-25.41	0	0	0	-0.16	-0.16
25.608	-28.349	-0.082	25.608	-28.349	0	0	0	-0.082	-0.082
33.594	-23.355	-0.039	33.594	-23.355	0	0	0	-0.039	-0.039
61.683	-24.5	0.022	61.683	-24.5	0	0	0	0.022	0.022
68.063	-35.023	0.137	68.063	-35.023	0	0	0	0.137	0.137
65.258	-54.994	0.178	65.258	-54.994	0	0	0	0.178	0.178
68.918	-6.573	0.047	68.918	-6.573	0	0	0	0.047	0.047
66.091	18.427	0.052	66.091	18.427	0	0	0	0.052	0.052
52.184	19.005	0.007	52.184	19.005	0	0	0	0.007	0.007
38.308	18.754	0.064	38.308	18.754	0	0	0	0.064	0.064
24.955	19.079	-0.02	24.955	19.079	0	0	0	-0.02	-0.02
27.057	28.538	-0.084	27.057	28.538	0	0	0	-0.084	-0.084
34.199	26.874	0.076	34.199	26.874	0	0	0	0.076	0.076
45.94	25.938	0.044	45.94	25.938	0	0	0	0.044	0.044
45.623	34.481	0.043	45.623	34.481	0	0	0	0.043	0.043
29.65	39.394	-0.03	29.65	39.394	0	0	0	-0.03	-0.03
17.294	42.238	0.044	17.294	42.238	0	0	0	0.044	0.044
7.053	39.366	-0.045	7.053	39.366	0	0	0	-0.045	-0.045
10.223	49.417	-0.088	10.223	49.417	0	0	0	-0.088	-0.088
22.911	52.381	0.021	22.911	52.381	0	0	0	0.021	0.021
43.213	55.632	0.046	43.213	55.632	0	0	0	0.046	0.046
66.405	54.298	0.247	66.405	54.298	0	0	0	0.247	0.247
66.993	38.321	0.135	66.993	38.321	0	0	0	0.135	0.135
-12.232	40.842	-0.118	-12.232	40.842	0	0	0	-0.118	-0.118
-22.807	17.545	-0.171	-22.807	17.545	0	0	0	-0.171	-0.171
-24.11	30.738	-0.061	-24.11	30.738	0	0	0	-0.061	-0.061
-31.287	26.052	-0.024	-31.287	26.052	0	0	0	-0.024	-0.024

-43.018	26.714	-0.067	-43.018	26.714	0	0	0	-0.067	-0.067
-50.511	30.567	0.046	-50.511	30.567	0	0	0	0.046	0.046
-40.465	46.118	-0.054	-40.465	46.118	0	0	0	-0.054	-0.054
-47.588	54.675	0.072	-47.588	54.675	0	0	0	0.072	0.072
-75.599	53.89	0.396	-75.599	53.89	0	0	0	0.396	0.396
-75.816	37.608	0.381	-75.816	37.608	0	0	0	0.381	0.381
-74.6	19.45	0.143	-74.6	19.45	0	0	0	0.143	0.143
-57.122	25.353	0.088	-57.122	25.353	0	0	0	0.088	0.088
-66.162	12.045	0.122	-66.162	12.045	0	0	0	0.122	0.122
-68.675	-1.013	0.082	-68.675	-1.013	0	0	0	0.082	0.082
-77.029	-10.708	0.193	-77.029	-10.708	0	0	0	0.193	0.193
-76.891	-29.183	0.22	-76.891	-29.183	0	0	0	0.22	0.22
-62.625	-24.78	0.018	-62.625	-24.78	0	0	0	0.018	0.018
-49.939	-21.818	-0.143	-49.939	-21.818	0	0	0	-0.143	-0.143
-35.61	-26.52	-0.043	-35.61	-26.52	0	0	0	-0.043	-0.043
-22.855	-18.036	-0.135	-22.855	-18.036	0	0	0	-0.135	-0.135
-27.869	-36.982	-0.08	-27.869	-36.982	0	0	0	-0.08	-0.08
-13.739	-51.064	-0.172	-13.739	-51.064	0	0	0	-0.172	-0.172
-5.24	-60.12	-0.108	-5.24	-60.12	0	0	0	-0.108	-0.108
-6.476	-70.922	-0.037	-6.476	-70.922	0	0	0	-0.037	-0.037
-7.82	-86.139	0.074	-7.82	-86.139	0	0	0	0.074	0.074
-27.248	-90.735	0.121	-27.248	-90.735	0	0	0	0.121	0.121
-40.941	-88.492	0.09	-40.941	-88.492	0	0	0	0.09	0.09
-53.698	-82.079	0.202	-53.698	-82.079	0	0	0	0.202	0.202
-62.906	-90.704	0.382	-62.906	-90.704	0	0	0	0.382	0.382
-77.233	-86.003	0.368	-77.233	-86.003	0	0	0	0.368	0.368
-75.576	-64.43	0.259	-75.576	-64.43	0	0	0	0.259	0.259
-71.969	-44.161	0.19	-71.969	-44.161	0	0	0	0.19	0.19
-65.813	-56.065	0.168	-65.813	-56.065	0	0	0	0.168	0.168
-62.185	-65.857	0.158	-62.185	-65.857	0	0	0	0.158	0.158
-50.471	-58.792	0.071	-50.471	-58.792	0	0	0	0.071	0.071
-50.225	-72.851	0.091	-50.225	-72.851	0	0	0	0.091	0.091
-14.1	-37.916	-17.189	-14.1	-37.916	-16.833	0	0	-0.356	-0.356
-14.495	-16.519	-17.217	-14.495	-16.519	-16.833	0	0	-0.383	-0.383
-13.678	16.158	-17.097	-13.678	16.158	-16.833	0	0	-0.263	-0.263
-13.509	29.365	-17.055	-13.509	29.365	-16.833	0	0	-0.222	-0.222
14.55	31.627	-17.039	14.55	31.627	-16.833	0	0	-0.206	-0.206
15.419	23.919	-17.079	15.419	23.919	-16.833	0	0	-0.245	-0.245
15.682	12.227	-17.201	15.682	12.227	-16.833	0	0	-0.368	-0.368
59.869	4.313	-16.974	59.869	4.313	-16.833	0	0	-0.141	-0.141
58.309	-9.959	-16.927	58.309	-9.959	-16.833	0	0	-0.093	-0.093

48.817	-15.252	-16.97	48.817	-15.252	-16.833	0	0	-0.137	-0.137
36.408	-9.655	-17.129	36.408	-9.655	-16.833	0	0	-0.296	-0.296
30.639	-17.68	-17.131	30.639	-17.68	-16.833	0	0	-0.297	-0.297
13.179	-15.161	-17.179	13.179	-15.161	-16.833	0	0	-0.346	-0.346
19.471	2.819	-4.593	19.471	2.819	-4.208	0	0	-0.385	-0.385
28.857	7.227	-4.512	28.857	7.227	-4.208	0	0	-0.303	-0.303
34.381	2.97	-4.461	34.381	2.97	-4.208	0	0	-0.252	-0.252
41.137	7.349	-4.494	41.137	7.349	-4.208	0	0	-0.286	-0.286
46.363	2.165	-4.36	46.363	2.165	-4.208	0	0	-0.151	-0.151
51.961	8.382	-4.426	51.961	8.382	-4.208	0	0	-0.218	-0.218
50.789	-3.213	-0.043	50.789	-3.213	0	0	0	-0.043	-0.043
40.267	-3.009	-0.004	40.267	-3.009	0	0	0	-0.004	-0.004
28.574	-2.818	-0.056	28.574	-2.818	0	0	0	-0.056	-0.056
16.886	-2.01	-0.167	16.886	-2.01	0	0	0	-0.167	-0.167
18.505	-9.339	1.429	18.505	-9.339	1.683	0	0	-0.255	-0.255
24.664	-6.506	1.413	24.664	-6.506	1.683	0	0	-0.27	-0.27
25.777	-14.814	1.479	25.777	-14.814	1.683	0	0	-0.204	-0.204
18.737	-12.383	-3.866	18.737	-12.447	-3.866	0	0.064	0	-0.064
25.635	-16.653	0.516	25.635	-16.655	0.516	0	0.003	0	-0.003
32.944	-3.951	-3.929	32.944	-4.03	-3.929	0	0.079	0	-0.079
39.967	-3.974	-3.175	39.967	-4.03	-3.175	0	0.057	0	-0.057
52.589	-3.94	-4.45	52.589	-4.03	-4.45	0	0.091	0	-0.091
55.546	-0.029	-8.727	55.25	0.065	-8.727	0.296	-0.095	0	0.311
56.866	7.901	-9.468	56.527	7.901	-9.468	0.339	0	0	0.339
59.424	12.437	-0.537	59.424	12.457	-0.579	0	-0.02	0.043	0.047
49.208	13.343	-1.411	49.208	13.283	-1.308	0	0.06	-0.104	-0.12
39.369	12.608	-1.288	39.369	12.51	-1.19	0	0.098	-0.098	-0.139

### 3D-Tol Data from CMM for ThermoJet Magnesium Casting

MEAS X	MEAS Y	MEAS Z	CAD X	CAD Y	CAD Z	DIF X	DIF Y	DIF Z	TOT DIF
53.705	58.639	-5.717	53.705	58.917	-5.717	0	-0.278	0	-0.278
37.159	58.55	-5.727	37.159	58.917	-5.727	0	-0.367	0	-0.367
20.615	58.574	-5.737	20.615	58.917	-5.737	0	-0.342	0	-0.342
4.07	58.602	-5.747	4.07	58.917	-5.747	0	-0.315	0	-0.315
-12.475	58.57	-5.758	-12.475	58.917	-5.758	0	-0.347	0	-0.347
-29.019	58.581	-5.767	-29.019	58.917	-5.767	0	-0.336	0	-0.336
-45.563	58.633	-5.778	-45.563	58.917	-5.778	0	-0.284	0	-0.284
-62.109	58.674	-5.787	-62.109	58.917	-5.787	0	-0.242	0	-0.242
-79.668	41.069	-5.811	-79.958	41.069	-5.811	0.29	0	0	-0.29
-79.593	24.524	-5.82	-79.958	24.524	-5.82	0.365	0	0	-0.365

-79.533	7.979	-5.829	-79.958	7.979	-5.829	0.426	0	0	-0.426
-79.528	-8.565	-5.838	-79.958	-8.565	-5.838	0.43	0	0	-0.43
-79.51	-25.11	-5.847	-79.958	-25.11	-5.847	0.448	0	0	-0.448
-79.511	-41.655	-5.856	-79.958	-41.655	-5.856	0.448	0	0	-0.448
-79.531	-58.2	-5.865	-79.958	-58.2	-5.865	0.427	0	0	-0.427
-79.533	-74.745	-5.873	-79.958	-74.745	-5.873	0.425	0	0	-0.425
-62.157	-92.232	-5.872	-62.157	-92.583	-5.872	0	0.352	0	-0.352
-45.612	-92.162	-5.861	-45.612	-92.583	-5.861	0	0.422	0	-0.422
-29.068	-92.053	-5.85	-29.068	-92.583	-5.85	0	0.53	0	-0.53
-12.524	-92.008	-5.84	-12.524	-92.583	-5.84	0	0.575	0	-0.575
4.022	-92.063	-5.829	4.022	-92.583	-5.829	0	0.52	0	-0.52
20.567	-92.18	-5.82	20.567	-92.583	-5.82	0	0.404	0	-0.404
37.111	-92.17	-5.81	37.111	-92.583	-5.81	0	0.414	0	-0.414
53.656	-92.157	-5.799	53.656	-92.583	-5.799	0	0.426	0	-0.426
71.172	-74.793	-5.776	71.542	-74.793	-5.776	-0.37	0	0	-0.37
71.17	-58.25	-5.767	71.542	-58.25	-5.767	-0.372	0	0	-0.372
71.187	-41.704	-5.758	71.542	-41.704	-5.758	-0.354	0	0	-0.354
71.22	-25.16	-5.749	71.542	-25.16	-5.749	-0.322	0	0	-0.322
71.234	-8.615	-5.74	71.542	-8.615	-5.74	-0.307	0	0	-0.307
71.172	7.93	-5.732	71.542	7.93	-5.732	-0.369	0	0	-0.369
71.178	24.475	-5.723	71.542	24.475	-5.723	-0.363	0	0	-0.363
71.135	41.018	-5.713	71.542	41.018	-5.713	-0.407	0	0	-0.407
-69.867	43.75	8.716	-69.867	43.75	8.417	0	0	0.3	0.3
-64.816	43.749	8.686	-64.816	43.749	8.417	0	0	0.27	0.27
-64.815	48.8	8.67	-64.815	48.8	8.417	0	0	0.253	0.253
-69.865	48.8	8.696	-69.865	48.8	8.417	0	0	0.28	0.28
-67.735	46.396	8.64	-67.735	46.396	8.417	0	0	0.223	0.223
-71.358	43.753	6.82	-71.542	43.753	6.82	0.183	0	0	-0.183
-71.363	48.801	6.824	-71.542	48.801	6.824	0.178	0	0	-0.178
-69.861	50.344	6.828	-69.861	50.5	6.828	0	-0.156	0	-0.156
-64.811	50.355	6.832	-64.811	50.5	6.832	0	-0.145	0	-0.145
-64.813	42.06	6.824	-64.813	42.083	6.824	0	-0.023	0	0.023
-69.864	41.981	6.821	-69.864	42.083	6.821	0	-0.102	0	0.102
-63.025	48.801	6.832	-63.125	48.801	6.832	0.1	0	0	0.1
-63.012	43.752	6.829	-63.125	43.752	6.829	0.113	0	0	0.113
-64.831	-14.323	3.98	-64.831	-14.323	4.208	0	0	-0.229	-0.229
-69.884	-14.322	4.103	-69.884	-14.322	4.208	0	0	-0.105	-0.105
-69.884	-19.373	4.129	-69.884	-19.373	4.208	0	0	-0.079	-0.079
-64.834	-19.373	4.014	-64.834	-19.373	4.208	0	0	-0.194	-0.194
-68.005	-16.751	3.991	-68.005	-16.751	4.208	0	0	-0.217	-0.217
-69.88	-12.607	3.427	-69.88	-12.625	3.427	0	0.018	0	0.018

-64.83	-12.609	3.431	-64.83	-12.625	3.431	0	0.016	0	0.016
-62.864	-14.322	3.431	-63.125	-14.322	3.431	0.261	0	0	0.261
-62.892	-19.372	3.429	-63.125	-19.372	3.429	0.233	0	0	0.233
-64.833	-21	3.423	-64.833	-21.042	3.423	0	0.042	0	-0.042
-69.883	-20.988	3.42	-69.883	-21.042	3.42	0	0.054	0	-0.054
-71.572	-19.37	4.172	-71.542	-19.37	4.208	-0.03	0	-0.036	0.048
-71.569	-14.322	4.176	-71.542	-14.322	4.208	-0.027	0	-0.033	0.043
-64.856	-77.451	8.627	-64.856	-77.451	8.417	0	0	0.21	0.21
-69.908	-77.45	8.642	-69.908	-77.45	8.417	0	0	0.225	0.225
-69.908	-82.5	8.65	-69.908	-82.5	8.417	0	0	0.233	0.233
-64.858	-82.501	8.635	-64.858	-82.501	8.417	0	0	0.218	0.218
-69.904	-75.612	6.76	-69.904	-75.75	6.76	0	0.138	0	0.138
-64.853	-75.618	6.763	-64.853	-75.75	6.763	0	0.132	0	0.132
-63.025	-77.449	6.764	-63.125	-77.449	6.764	0.1	0	0	0.1
-63.028	-82.498	6.761	-63.125	-82.498	6.761	0.097	0	0	0.097
-64.855	-83.91	6.756	-64.855	-84.167	6.756	0	0.256	0	-0.256
-69.907	-83.916	6.753	-69.907	-84.167	6.753	0	0.251	0	-0.251
-71.365	-82.497	6.752	-71.542	-82.497	6.752	0.177	0	0	-0.177
-71.367	-77.449	6.756	-71.542	-77.449	6.756	0.175	0	0	-0.175
-2.531	43.73	4.212	-2.531	43.73	4.208	0	0	0.003	0.003
2.521	43.729	4.211	2.521	43.729	4.208	0	0	0.003	0.003
2.521	48.78	4.218	2.521	48.78	4.208	0	0	0.009	0.009
-2.529	48.781	4.217	-2.529	48.781	4.208	0	0	0.008	0.008
-0.689	46.765	4.144	-0.689	46.765	4.208	0	0	-0.064	-0.064
-4.23	43.733	2.232	-4.208	43.733	2.232	-0.021	0	0	0.021
-4.232	48.782	2.237	-4.208	48.782	2.237	-0.024	0	0	0.024
2.523	42.089	2.236	2.523	42.083	2.236	0	0.006	0	-0.006
-2.528	42.074	2.233	-2.528	42.083	2.233	0	-0.009	0	0.009
4.085	48.781	2.244	4.208	48.781	2.244	-0.123	0	0	-0.123
4.085	43.73	2.24	4.208	43.73	2.24	-0.123	0	0	-0.123
-2.526	50.318	2.239	-2.526	50.5	2.239	0	-0.182	0	-0.182
2.526	50.316	2.244	2.526	50.5	2.244	0	-0.184	0	-0.184
-64.564	35.98	-1.173	-64.792	36.208	-1.173	0.228	-0.228	0	0.322
-53.854	46.698	-1.161	-54.078	46.922	-1.161	0.224	-0.224	0	0.317
-47.014	46.829	-1.158	-46.922	46.922	-1.158	-0.093	-0.093	0	0.131
-36.265	36.152	-1.157	-36.209	36.209	-1.157	-0.056	-0.056	0	0.08
-40.98	29.058	-1.161	-40.971	29.068	-1.161	-0.01	-0.01	0	-0.014
-48.139	36.181	-1.162	-48.111	36.208	-1.162	-0.027	-0.027	0	-0.039
-35.675	29.481	-1.541	-35.742	29.549	-1.541	0.068	-0.068	0	-0.096
-53.93	34.863	-1.169	-54.082	35.015	-1.169	0.152	-0.152	0	-0.215
-58.67	30.086	-1.174	-58.841	30.256	-1.174	0.171	-0.171	0	-0.242

-65.297	29.706	-1.077	-65.356	29.647	-1.077	0.059	0.059	0	0.083
-61.4	33.548	-4.216	-61.4	33.548	-4.208	0	0	-0.007	-0.007
-56.83	38.302	-4.252	-56.83	38.302	-4.208	0	0	-0.044	-0.044
-50.332	43.702	-4.227	-50.332	43.702	-4.208	0	0	-0.018	-0.018
-44.773	38.653	-4.26	-44.773	38.653	-4.208	0	0	-0.052	-0.052
-40.1	33.843	-4.308	-40.1	33.843	-4.208	0	0	-0.099	-0.099
49.654	42.152	6.052	49.654	42.083	6.052	0	0.069	0	-0.069
42.919	42.155	6.048	42.919	42.083	6.048	0	0.072	0	-0.072
54.567	30.244	6.05	54.708	30.244	6.05	-0.141	0	0	0.141
54.579	36.978	6.054	54.708	36.978	6.054	-0.129	0	0	0.129
58.788	25.486	5.555	58.788	25.25	5.555	0	0.236	0	-0.236
62.894	30.242	6.057	63.125	30.242	6.057	-0.231	0	0	-0.231
62.875	37.818	6.062	63.125	37.818	6.062	-0.25	0	0	-0.25
62.904	45.393	6.067	63.125	45.393	6.067	-0.221	0	0	-0.221
58.072	50.4	6.064	58.072	50.5	6.064	0	-0.1	0	-0.1
50.496	50.39	6.06	50.496	50.5	6.06	0	-0.11	0	-0.11
42.921	50.413	6.056	42.921	50.5	6.056	0	-0.087	0	-0.087
37.863	46.193	5.329	37.875	46.193	5.329	-0.012	0	0	0.012
43.168	46.357	8.469	43.168	46.357	8.417	0	0	0.052	0.052
50.4	46.065	8.417	50.4	46.065	8.417	0	0	0	0
58.37	45.73	8.435	58.37	45.73	8.417	0	0	0.019	0.019
59.107	37.465	8.431	59.107	37.465	8.417	0	0	0.015	0.015
58.982	30.62	8.519	58.982	30.62	8.417	0	0	0.102	0.102
-30.913	48.863	17.065	-30.913	48.911	17.038	0	-0.048	0.028	0.055
-30.91	45.945	12.045	-30.91	46.008	12.009	0	-0.062	0.036	0.072
-30.908	43.072	7.002	-30.908	43.106	6.983	0	-0.033	0.019	0.039
-30.906	40.176	1.975	-30.906	40.205	1.959	0	-0.029	0.017	0.034
-27.117	40.221	1.954	-27.117	40.207	1.962	0	0.014	-0.008	-0.017
-27.121	43.118	6.977	-27.121	43.106	6.984	0	0.012	-0.007	-0.013
-27.123	45.936	12.052	-27.123	46.008	12.011	0	-0.072	0.042	0.083
-27.126	48.886	17.053	-27.126	48.911	17.039	0	-0.025	0.015	0.029
-23.336	48.887	17.054	-23.336	48.912	17.04	0	-0.025	0.014	0.028
-23.335	46.001	12.015	-23.335	46.008	12.01	0	-0.007	0.004	0.009
-23.333	43.118	6.978	-23.333	43.107	6.985	0	0.011	-0.007	-0.013
-23.331	40.266	1.926	-23.331	40.206	1.96	0	0.06	-0.035	-0.069
-17.016	45.341	2.019	-17.016	45.439	1.993	0	-0.098	0.026	0.101
-17.022	47.437	9.537	-17.022	47.459	9.531	0	-0.022	0.006	0.023
-17.026	49.491	17.066	-17.026	49.479	17.069	0	0.012	-0.003	-0.012
-11.973	49.49	17.069	-11.973	49.479	17.071	0	0.01	-0.003	-0.011
-11.971	47.421	9.544	-11.971	47.46	9.534	0	-0.039	0.01	0.04
-11.966	45.348	2.019	-11.966	45.44	1.995	0	-0.092	0.025	0.095

-8.316	49.583	7.66	-8.178	49.583	7.66	-0.138	0	0	-0.138
-30.912	51.039	15.223	-30.912	50.934	15.195	0	0.105	0.028	0.109
-30.909	52.412	9.532	-30.909	52.448	9.542	0	-0.037	-0.01	-0.038
-30.905	53.752	3.832	-30.905	53.963	3.889	0	-0.212	-0.057	-0.219
-24.17	53.716	3.828	-24.17	53.962	3.894	0	-0.246	-0.066	-0.255
-24.175	52.395	9.533	-24.175	52.447	9.547	0	-0.052	-0.014	-0.054
-24.178	51.041	15.229	-24.178	50.932	15.2	0	0.109	0.029	0.113
-17.445	51.059	15.239	-17.445	50.931	15.205	0	0.128	0.034	0.132
-17.442	52.42	9.544	-17.442	52.446	9.551	0	-0.026	-0.007	-0.027
-17.44	53.713	3.831	-17.44	53.961	3.897	0	-0.248	-0.066	-0.257
-10.703	53.747	3.844	-10.703	53.96	3.901	0	-0.213	-0.057	-0.22
-10.708	52.454	9.558	-10.708	52.445	9.555	0	0.009	0.002	0.01
-10.712	51.086	15.251	-10.712	50.93	15.209	0	0.156	0.042	0.162
-33.331	48.932	9.784	-33.428	48.932	9.784	0.097	0	0	-0.097
5	-63.171	18.927	5.067	-63.171	18.909	-0.066	0	0.018	0.069
3.182	-63.168	11.838	3.173	-63.168	11.84	0.009	0	-0.003	-0.01
1.381	-63.163	4.745	1.279	-63.163	4.772	0.102	0	-0.027	-0.106
1.406	-69.897	4.735	1.278	-69.897	4.769	0.128	0	-0.034	-0.133
3.218	-69.9	11.824	3.172	-69.9	11.837	0.047	0	-0.013	-0.048
5.035	-69.905	18.912	5.065	-69.905	18.904	-0.03	0	0.008	0.031
5.043	-76.639	18.904	5.064	-76.639	18.898	-0.021	0	0.006	0.021
3.223	-76.634	11.82	3.171	-76.634	11.834	0.052	0	-0.014	-0.054
1.388	-76.631	4.735	1.277	-76.631	4.765	0.111	0	-0.03	-0.115
1.338	-83.364	4.744	1.276	-83.364	4.761	0.063	0	-0.017	-0.065
3.187	-83.368	11.825	3.17	-83.368	11.83	0.018	0	-0.005	-0.018
5.023	-83.371	18.908	5.063	-83.371	18.897	-0.041	0	0.011	0.042
7.411	-85.557	10.429	7.411	-85.85	10.429	0	0.293	0	-0.293
7.68	-83.369	21.312	7.627	-83.369	21.281	0.053	0	0.03	0.061
13.065	-83.37	11.852	13.07	-83.37	11.855	-0.005	0	-0.003	-0.005
18.393	-83.364	2.364	18.51	-83.364	2.431	-0.117	0	-0.068	-0.135
18.356	-75.79	2.344	18.509	-75.79	2.433	-0.154	0	-0.089	-0.178
13.025	-75.795	11.833	13.068	-75.795	11.858	-0.043	0	-0.025	-0.049
7.668	-75.798	21.309	7.625	-75.798	21.285	0.042	0	0.024	0.049
6.951	-69.483	21.293	6.922	-69.483	21.286	0.029	0	0.008	0.03
9.403	-69.479	11.853	9.446	-69.479	11.864	-0.043	0	-0.012	-0.045
11.825	-69.476	2.401	11.971	-69.476	2.44	-0.146	0	-0.039	-0.151
11.853	-64.426	2.411	11.97	-64.426	2.443	-0.118	0	-0.031	-0.122
9.432	-64.431	11.863	9.445	-64.431	11.867	-0.014	0	-0.004	-0.014
6.975	-64.436	21.304	6.921	-64.436	21.289	0.055	0	0.015	0.057
6.4	-60.644	11.192	6.4	-60.6	11.192	0	-0.044	0	-0.044
-30.571	-50.371	-5.45	-30.567	-50.433	-5.384	-0.004	0.062	-0.066	-0.091

-30.275	-55.016	-7.911	-30.272	-55.06	-7.826	-0.003	0.044	-0.084	-0.095
-30.054	-58.491	-11.587	-30.051	-58.543	-11.56	-0.003	0.051	-0.027	-0.058
-29.855	-61.586	-15.751	-29.86	-61.521	-15.841	0.005	-0.066	0.09	0.111
-33.787	-63.501	-15.734	-33.837	-63.456	-15.824	0.05	-0.045	0.091	0.113
-36.06	-61.468	-11.56	-36.048	-61.479	-11.552	-0.012	0.011	-0.008	-0.018
-38.679	-59.121	-7.87	-38.658	-59.14	-7.816	-0.021	0.019	-0.054	-0.06
-42.147	-56.016	-5.423	-42.109	-56.05	-5.37	-0.038	0.034	-0.054	-0.074
-46.391	-68.129	-5.342	-46.405	-68.13	-5.357	0.014	0.001	0.015	0.021
-41.766	-67.915	-7.787	-41.778	-67.916	-7.809	0.012	0.001	0.022	0.025
-38.173	-67.751	-11.5	-38.265	-67.755	-11.549	0.092	0.004	0.049	0.104
-35.203	-67.612	-15.669	-35.312	-67.617	-15.815	0.109	0.005	0.146	0.182
-33.35	-71.508	-15.599	-33.459	-71.624	-15.811	0.109	0.117	0.213	0.266
-35.319	-73.627	-11.434	-35.467	-73.786	-11.548	0.148	0.159	0.115	0.246
-37.815	-76.316	-7.677	-37.861	-76.365	-7.808	0.046	0.05	0.131	0.147
-40.908	-79.65	-5.193	-41.013	-79.762	-5.353	0.104	0.112	0.159	0.221
-29.79	-67.436	-16.721	-29.771	-67.43	-16.878	-0.019	-0.006	0.157	0.158
-26.711	-62.265	-15.778	-26.687	-62.22	-15.848	-0.025	-0.045	0.07	0.087
-25.205	-59.511	-11.611	-25.25	-59.593	-11.561	0.045	0.083	-0.05	-0.107
-23.545	-56.511	-7.91	-23.566	-56.547	-7.831	0.021	0.036	-0.079	-0.089
-21.31	-52.383	-5.494	-21.356	-52.468	-5.391	0.046	0.085	-0.103	-0.142
-13.124	-62.557	-5.493	-13.213	-62.583	-5.394	0.089	0.026	-0.099	-0.135
-17.636	-63.879	-7.888	-17.663	-63.887	-7.833	0.028	0.008	-0.055	-0.062
-20.966	-64.855	-11.588	-21.004	-64.866	-11.567	0.038	0.011	-0.021	-0.045
-23.942	-65.725	-15.759	-23.878	-65.706	-15.851	-0.065	-0.019	0.092	0.114
-24.467	-70.1	-15.678	-24.362	-70.158	-15.841	-0.105	0.058	0.162	0.202
-21.844	-71.539	-11.504	-21.747	-71.593	-11.563	-0.096	0.053	0.058	0.125
-18.704	-73.252	-7.779	-18.682	-73.264	-7.826	-0.022	0.012	0.048	0.054
-14.637	-75.483	-5.366	-14.62	-75.492	-5.387	-0.017	0.01	0.021	0.029
-24.781	-83.447	-5.188	-24.733	-83.613	-5.37	-0.048	0.166	0.182	0.251
-26.055	-79.093	-7.672	-26.034	-79.166	-7.817	-0.021	0.073	0.145	0.164
-27.087	-75.565	-11.427	-27.019	-75.801	-11.557	-0.068	0.236	0.13	0.278
-27.903	-72.776	-15.576	-27.852	-72.955	-15.826	-0.051	0.179	0.25	0.312
-32.204	-72.316	-15.583	-32.288	-72.468	-15.814	0.084	0.152	0.232	0.289
-33.588	-74.841	-11.418	-33.707	-75.058	-11.549	0.119	0.217	0.131	0.28
-35.358	-78.075	-7.658	-35.395	-78.144	-7.809	0.038	0.069	0.151	0.17
-37.531	-82.052	-5.167	-37.618	-82.21	-5.354	0.087	0.158	0.188	0.26
-25.503	-86.152	-0.37	-25.471	-86.304	-0.562	-0.032	0.153	0.193	0.248
-13.002	-77.275	-0.784	-13.037	-77.254	-0.743	0.035	-0.021	-0.041	-0.058
-10.885	-61.737	-0.904	-11.061	-61.79	-0.715	0.177	0.053	-0.19	-0.264
-15.969	-53.384	-0.883	-16.091	-53.51	-0.7	0.122	0.126	-0.183	-0.254
-25.795	-48.117	-0.762	-25.826	-48.281	-0.554	0.031	0.164	-0.208	-0.266

-47.195	-37.743	19.031	-47.238	-37.763	19.004	0.042	0.02	0.027	0.054
-43.944	-36.204	12.688	-43.943	-36.203	12.689	-0.002	-0.001	-0.001	-0.002
-40.711	-34.668	6.341	-40.652	-34.64	6.379	-0.059	-0.028	-0.038	-0.075
-39.904	-41.322	6.306	-39.794	-41.343	6.371	-0.11	0.021	-0.065	-0.13
-43.406	-40.666	12.666	-43.376	-40.671	12.684	-0.03	0.006	-0.018	-0.035
-46.936	-40	19.009	-46.957	-39.996	18.997	0.022	-0.004	0.013	0.025
-48.064	-41.941	18.973	-48.048	-41.958	18.986	-0.016	0.017	-0.014	-0.027
-45.604	-44.545	12.622	-45.545	-44.609	12.672	-0.06	0.064	-0.05	-0.101
-43.155	-47.138	6.264	-43.042	-47.258	6.359	-0.113	0.12	-0.095	-0.19
-49.163	-49.939	6.236	-49.139	-50.129	6.347	-0.024	0.19	-0.11	-0.221
-49.621	-46.41	12.598	-49.608	-46.515	12.659	-0.013	0.105	-0.061	-0.122
-50.08	-42.848	18.936	-50.074	-42.902	18.968	-0.006	0.054	-0.031	-0.063
-52.182	-42.388	18.891	-52.242	-42.488	18.958	0.059	0.1	-0.067	-0.134
-53.898	-45.534	12.545	-53.988	-45.686	12.647	0.091	0.152	-0.102	-0.204
-55.625	-48.7	6.211	-55.736	-48.884	6.335	0.11	0.184	-0.124	-0.247
-51.788	-39.914	22.73	-51.807	-39.923	22.742	0.019	0.009	-0.012	-0.024
-56.902	-42.337	12.532	-57.076	-42.419	12.644	0.174	0.083	-0.111	-0.223
-62.089	-44.789	2.381	-62.347	-44.911	2.545	0.258	0.122	-0.165	-0.329
-63.095	-36.95	2.382	-63.383	-36.897	2.551	0.288	-0.054	-0.169	-0.338
-57.499	-38.008	12.562	-57.653	-37.979	12.652	0.154	-0.028	-0.09	-0.181
-51.931	-39.053	22.753	-51.923	-39.055	22.749	-0.008	0.001	0.005	0.009
-51.536	-38.25	22.784	-51.509	-38.277	22.762	-0.028	0.028	0.023	0.045
-55.442	-34.119	12.603	-55.516	-34.042	12.664	0.073	-0.077	-0.061	-0.122
-59.382	-29.937	2.452	-59.514	-29.797	2.563	0.132	-0.139	-0.111	-0.222
-52.191	-26.403	2.533	-52.202	-26.323	2.58	0.011	-0.081	-0.047	-0.094
-51.459	-32.13	12.665	-51.462	-32.106	12.679	0.003	-0.024	-0.014	-0.028
-50.725	-37.789	22.833	-50.71	-37.887	22.776	-0.015	0.098	0.057	0.114
-49.78	-37.953	22.848	-49.83	-38.046	22.787	0.05	0.093	0.061	0.122
-47.036	-32.928	12.691	-47.037	-32.929	12.69	0.001	0.001	0.001	0.001
-44.262	-27.884	2.55	-44.228	-27.82	2.591	-0.034	-0.064	-0.042	-0.084
-46.305	3.92	25.153	-46.255	3.874	25.22	-0.049	0.046	-0.066	-0.095
-50.304	7.7	27.348	-50.343	7.737	27.521	0.039	-0.037	-0.173	-0.181
-53.577	10.801	21.84	-53.748	10.961	21.944	0.171	-0.16	-0.103	-0.256
-56.25	13.341	8.301	-56.451	13.53	8.352	0.201	-0.19	-0.051	-0.281
-61.392	-1.585	8.269	-61.756	-1.615	8.336	0.364	0.03	-0.067	-0.372
-57.788	-1.299	21.813	-58.043	-1.321	21.926	0.256	0.021	-0.113	-0.28
-53.325	-0.941	27.316	-53.388	-0.946	27.513	0.063	0.005	-0.196	-0.206
-47.839	-0.501	25.165	-47.769	-0.495	25.235	-0.07	-0.006	-0.069	-0.099
-45.582	-4.572	25.197	-45.555	-4.537	25.24	-0.027	-0.035	-0.044	-0.062
-48.945	-8.976	27.337	-48.979	-9.02	27.509	0.034	0.044	-0.172	-0.181
-51.663	-12.534	21.813	-51.81	-12.726	21.919	0.147	0.192	-0.106	-0.264

-53.935	-15.517	8.292	-54.065	-15.687	8.332	0.13	0.171	-0.039	-0.218
-38.485	-19.304	8.323	-38.466	-19.403	8.342	-0.019	0.1	-0.019	-0.103
-39.193	-15.573	21.854	-39.162	-15.744	21.93	-0.032	0.171	-0.077	-0.19
-40.037	-11.12	27.408	-40.031	-11.153	27.514	-0.006	0.033	-0.106	-0.111
-41.073	-5.623	25.222	-41.075	-5.614	25.231	0.002	-0.009	-0.009	-0.013
-40.353	19.502	8.342	-40.339	19.655	8.37	-0.014	-0.154	-0.028	-0.157
-40.693	15.789	21.899	-40.68	15.936	21.964	-0.013	-0.147	-0.065	-0.161
-41.107	11.213	27.429	-41.104	11.244	27.53	-0.003	-0.031	-0.101	-0.106
-41.605	5.701	25.163	-41.608	5.658	25.205	0.004	0.043	-0.042	-0.06
-38.607	4.567	25.136	-38.646	4.514	25.2	0.04	0.052	-0.065	-0.092
-35.256	8.958	27.478	-35.246	8.971	27.533	-0.01	-0.013	-0.054	-0.057
-32.468	12.609	21.911	-32.385	12.719	21.971	-0.083	-0.109	-0.061	-0.15
-30.214	15.565	8.345	-30.119	15.69	8.374	-0.096	-0.126	-0.029	-0.16
-23.784	6.803	8.335	-23.588	6.876	8.373	-0.196	-0.073	-0.038	-0.213
-27.217	5.52	21.908	-27.088	5.568	21.969	-0.129	-0.048	-0.061	-0.151
-31.514	3.918	27.497	-31.504	3.922	27.532	-0.01	-0.004	-0.034	-0.036
-36.692	1.988	25.131	-36.759	1.963	25.201	0.067	0.025	-0.07	-0.1
-36.465	-1.217	25.147	-36.528	-1.204	25.211	0.064	-0.014	-0.064	-0.091
-31.041	-2.341	27.492	-31.03	-2.343	27.527	-0.01	0.002	-0.035	-0.036
-26.571	-3.268	21.896	-26.428	-3.298	21.96	-0.143	0.03	-0.064	-0.16
-22.999	-4.005	8.321	-22.771	-4.053	8.364	-0.229	0.048	-0.043	-0.238
-28.039	-13.598	8.32	-27.905	-13.728	8.355	-0.134	0.13	-0.034	-0.19
-30.716	-11.027	21.873	-30.595	-11.144	21.947	-0.121	0.118	-0.074	-0.184
-33.987	-7.881	27.458	-33.973	-7.894	27.521	-0.014	0.014	-0.063	-0.066
-37.99	-4.025	25.173	-38.024	-3.992	25.22	0.034	-0.033	-0.047	-0.067
-42.17	5.712	25.173	-42.169	5.679	25.206	-0.001	0.034	-0.033	-0.047
-42.216	11.261	27.439	-42.216	11.288	27.53	0	-0.028	-0.091	-0.095
-42.251	15.858	21.904	-42.252	15.996	21.965	0.001	-0.138	-0.061	-0.151
-42.277	19.582	8.34	-42.279	19.732	8.368	0.001	-0.15	-0.028	-0.152
-40.698	1.514	20.169	-40.77	1.435	20.235	0.072	0.079	-0.066	-0.126
-45.023	0.208	21.693	-44.982	0.205	21.722	-0.042	0.003	-0.028	-0.051
-40.739	-2.451	21.387	-40.781	-2.384	21.44	0.042	-0.067	-0.052	-0.095
45.069	-41.359	15.168	45.072	-41.354	15.129	-0.003	-0.005	0.039	0.04
42.466	-46.136	13.301	42.464	-46.139	13.307	0.002	0.003	-0.006	-0.007
40.327	-50.053	9.702	40.297	-50.106	9.757	0.03	0.053	-0.055	-0.083
38.894	-52.652	4.826	38.819	-52.79	4.89	0.075	0.138	-0.065	-0.17
31.949	-44.771	4.83	31.804	-44.828	4.894	0.145	0.057	-0.064	-0.168
34.719	-43.69	9.71	34.663	-43.712	9.764	0.056	0.022	-0.054	-0.081
38.875	-42.066	13.314	38.876	-42.066	13.312	-0.001	0	0.001	0.002
43.951	-40.088	15.185	43.958	-40.085	15.131	-0.008	-0.003	0.054	0.055
43.909	-38.393	15.194	43.918	-38.396	15.136	-0.008	0.003	0.057	0.058

38.729	-36.643	13.351	38.741	-36.647	13.326	-0.013	0.004	0.025	0.028
34.477	-35.204	9.757	34.449	-35.195	9.784	0.028	-0.009	-0.027	-0.04
31.616	-34.235	4.872	31.532	-34.206	4.909	0.085	-0.028	-0.037	-0.097
38.199	-25.941	4.902	38.16	-25.878	4.933	0.039	-0.063	-0.031	-0.081
39.769	-28.526	9.802	39.766	-28.521	9.808	0.004	-0.006	-0.006	-0.009
42.114	-32.382	13.398	42.128	-32.405	13.346	-0.015	0.024	0.052	0.059
44.964	-37.067	15.234	44.972	-37.079	15.143	-0.007	0.011	0.091	0.092
46.63	-36.734	15.231	46.628	-36.746	15.148	0.002	0.012	0.084	0.085
47.459	-31.298	13.435	47.453	-31.337	13.362	0.006	0.038	0.073	0.083
48.146	-26.814	9.843	48.144	-26.831	9.828	0.003	0.017	0.015	0.023
48.604	-23.817	4.926	48.612	-23.763	4.949	-0.008	-0.054	-0.023	-0.06
38.895	-52.652	4.826	38.819	-52.79	4.891	0.076	0.138	-0.065	-0.17
40.328	-50.051	9.701	40.297	-50.106	9.758	0.031	0.055	-0.057	-0.084
42.467	-46.134	13.301	42.465	-46.137	13.308	0.002	0.003	-0.007	-0.008
45.069	-41.358	15.169	45.072	-41.353	15.129	-0.003	-0.005	0.04	0.04
47.445	-37.011	15.227	47.439	-37.021	15.149	0.005	0.01	0.079	0.08
50.084	-32.19	13.423	50.069	-32.218	13.363	0.015	0.028	0.06	0.067
52.252	-28.222	9.824	52.255	-28.217	9.83	-0.003	-0.005	-0.006	-0.008
53.697	-25.576	4.913	53.743	-25.493	4.953	-0.046	-0.083	-0.04	-0.103
60.569	-33.595	4.85	60.785	-33.511	4.947	-0.216	-0.084	-0.096	-0.251
57.847	-34.657	9.78	57.894	-34.639	9.826	-0.047	-0.018	-0.046	-0.068
53.673	-36.291	13.404	53.651	-36.299	13.359	0.022	0.008	0.044	0.05
48.562	-38.285	15.213	48.553	-38.288	15.147	0.009	0.003	0.066	0.067
48.6	-39.981	15.199	48.592	-39.978	15.142	0.008	-0.003	0.057	0.058
53.784	-41.73	13.364	53.773	-41.726	13.343	0.011	-0.004	0.022	0.025
58.009	-43.154	9.741	58.077	-43.178	9.806	-0.068	0.023	-0.065	-0.097
60.713	-44.062	4.803	61.007	-44.162	4.932	-0.294	0.1	-0.129	-0.336
54.204	-52.229	4.804	54.337	-52.451	4.911	-0.134	0.221	-0.107	-0.279
52.691	-49.754	9.705	52.734	-49.825	9.78	-0.043	0.071	-0.075	-0.112
50.381	-45.961	13.336	50.378	-45.955	13.324	0.003	-0.006	0.012	0.014
47.543	-41.304	15.198	47.538	-41.296	15.135	0.005	-0.008	0.063	0.064
45.882	-41.636	15.187	45.883	-41.627	15.13	-0.001	-0.009	0.057	0.058
45.061	-47.023	13.323	45.062	-47.016	13.31	-0.001	-0.007	0.013	0.015
44.389	-51.438	9.721	44.382	-51.485	9.763	0.007	0.047	-0.043	-0.064
43.943	-54.377	4.835	43.922	-54.518	4.894	0.022	0.141	-0.059	-0.154
53.699	-25.573	4.914	53.743	-25.493	4.952	-0.045	-0.081	-0.038	-0.1
52.252	-28.222	9.825	52.255	-28.217	9.83	-0.003	-0.005	-0.005	-0.008
50.083	-32.192	13.424	50.068	-32.22	13.364	0.015	0.028	0.06	0.068
47.444	-37.011	15.225	47.439	-37.021	15.149	0.005	0.01	0.077	0.077
32.28	-49.641	0.256	32.216	-49.689	0.384	0.064	0.048	-0.128	-0.151
36.618	-53.995	0.163	36.588	-54.042	0.274	0.031	0.047	-0.111	-0.124

45.146	-56.239	0.567	45.14	-56.324	0.66	0.006	0.085	-0.093	-0.126
54.382	-53.879	0.768	54.464	-54.029	0.91	-0.082	0.15	-0.142	-0.223
60.52	-47.644	1.936	60.42	-47.584	1.998	0.1	-0.06	-0.062	0.133
62.836	-39.443	1.952	62.752	-39.442	1.998	0.084	-0.002	-0.046	0.096
5.501	29.307	-10.433	5.501	29.442	-10.393	0	-0.135	-0.041	-0.141
2.134	29.292	-10.44	2.134	29.443	-10.395	0	-0.151	-0.045	-0.158
2.126	26.356	0.147	2.126	26.287	0.126	0	0.069	0.021	0.072
-1.234	29.308	-10.438	-1.234	29.444	-10.397	0	-0.136	-0.041	-0.142
5.501	19.988	-12.504	5.501	20.044	-12.52	0	-0.055	0.017	0.057
2.128	23.15	-1.987	2.128	23.199	-2.002	0	-0.049	0.015	0.051
2.135	19.994	-12.507	2.135	20.043	-12.521	0	-0.049	0.015	0.051
-1.233	19.978	-12.503	-1.233	20.043	-12.522	0	-0.065	0.019	0.068
7.865	27.556	-10.456	7.982	27.556	-10.409	-0.117	0	-0.047	-0.126
7.86	25.032	-10.458	7.982	25.032	-10.409	-0.122	0	-0.049	-0.131
3.755	25.026	0.104	3.774	25.026	0.112	-0.019	0	-0.008	-0.021
7.874	22.506	-10.455	7.983	22.506	-10.411	-0.108	0	-0.043	-0.117
-4.476	27.562	-12.555	-4.557	27.562	-12.522	0.081	0	-0.033	-0.088
-0.364	25.027	-1.997	-0.35	25.027	-2.003	-0.015	0	0.006	0.016
-4.461	25.036	-12.561	-4.557	25.036	-12.523	0.096	0	-0.039	-0.104
-4.476	22.51	-12.556	-4.558	22.51	-12.524	0.082	0	-0.033	-0.088
-9.175	5.004	-1.997	-9.237	5.037	-1.997	0.062	-0.034	0	0.07
-9.166	4.988	9.788	-9.241	5.029	9.788	0.075	-0.041	0	0.086
-0.68	10.433	9.793	-0.684	10.499	9.793	0.004	-0.066	0	0.066
-0.667	10.372	-1.992	-0.675	10.499	-1.992	0.008	-0.127	0	0.127
8.495	6.142	-1.987	8.526	6.165	-1.987	-0.031	-0.022	0	0.038
8.435	6.102	9.797	8.524	6.166	9.797	-0.089	-0.064	0	0.11
9.864	-3.26	9.791	9.989	-3.301	9.791	-0.126	0.042	0	0.133
9.954	-3.282	0.954	9.992	-3.295	0.954	-0.038	0.013	0	0.04
-0.024	-10.492	0.946	-0.024	-10.521	0.946	0	0.029	0	0.029
-0.03	-10.501	9.786	-0.03	-10.521	9.786	0	0.02	0	0.02
-9.895	-3.245	9.782	-9.997	-3.278	9.782	0.102	0.033	0	0.107
-9.916	-3.25	0.945	-9.998	-3.277	0.945	0.081	0.027	0	0.086
10.569	-10.089	3.899	10.654	-10.171	3.899	-0.085	0.081	0	-0.118
-11.099	-9.487	3.882	-11.196	-9.571	3.882	0.097	0.083	0	-0.128
-14.471	1.88	0.94	-14.606	1.898	0.94	0.135	-0.018	0	-0.136
-8.28	12.005	3.898	-8.363	12.125	3.898	0.083	-0.12	0	-0.146
3.402	14.166	0.962	3.44	14.322	0.962	-0.037	-0.156	0	-0.16
12.832	6.93	3.91	12.96	6.999	3.91	-0.128	-0.069	0	-0.146
1.854	2.147	-16.838	1.854	2.147	-16.833	0	0	-0.005	-0.005
-3.82	3.82	-16.905	-3.82	3.82	-16.833	0	0	-0.071	-0.071
-3.904	-4.113	-16.89	-3.904	-4.113	-16.833	0	0	-0.057	-0.057

3.669	-3.97	-16.861	3.669	-3.97	-16.833	0	0	-0.028	-0.028
-0.374	0.194	-20.939	-0.374	0.194	-21.042	0	0	0.102	0.102
-9.418	-8.549	12.681	-9.418	-8.549	12.625	0	0	0.056	0.056
-12.055	3.509	12.692	-12.055	3.509	12.625	0	0	0.067	0.067
-0.979	11.985	12.709	-0.979	11.985	12.625	0	0	0.084	0.084
11.18	4.913	12.786	11.18	4.913	12.625	0	0	0.161	0.161
10.523	-7.027	12.765	10.523	-7.027	12.625	0	0	0.14	0.14
0.383	-12.831	12.679	0.383	-12.831	12.625	0	0	0.054	0.054
-0.49	-14.719	6.974	-0.49	-14.721	6.974	0	0.002	0	-0.002
6.916	-46.787	6.824	6.972	-46.787	6.824	-0.056	0	0	-0.056
6.925	-36.779	6.83	6.972	-36.779	6.83	-0.047	0	0	-0.047
6.918	-26.772	6.835	6.972	-26.772	6.835	-0.054	0	0	-0.054
6.924	-16.764	6.841	6.972	-16.764	6.841	-0.048	0	0	-0.048
4.453	-17.726	6.834	4.447	-17.726	6.834	0.006	0	0	-0.006
4.454	-27.449	6.828	4.447	-27.449	6.828	0.007	0	0	-0.007
4.468	-37.173	6.824	4.447	-37.173	6.824	0.021	0	0	-0.021
4.47	-46.894	6.818	4.447	-46.894	6.818	0.023	0	0	-0.023
-3.991	-46.907	9.765	-3.97	-46.907	9.765	-0.021	0	0	-0.021
-3.995	-37.221	9.769	-3.97	-37.221	9.769	-0.025	0	0	-0.025
-3.99	-27.537	9.774	-3.97	-27.537	9.774	-0.02	0	0	-0.02
-3.967	-17.851	9.779	-3.97	-17.851	9.779	0.003	0	0	0.003
-8.065	-16.108	3.881	-8.178	-16.108	3.881	0.113	0	0	-0.113
-8.08	-26.309	3.877	-8.178	-26.309	3.877	0.098	0	0	-0.098
-8.1	-36.51	3.87	-8.178	-36.51	3.87	0.078	0	0	-0.078
-8.1	-46.709	3.865	-8.178	-46.709	3.865	0.078	0	0	-0.078
-6.12	-50.239	7.262	-6.12	-50.5	7.262	0	0.261	0	-0.261
5.629	-50.27	10.503	5.629	-50.5	10.503	0	0.23	0	-0.23
5.624	-46.56	12.921	5.624	-46.56	12.625	0	0	0.296	0.296
5.648	-37.515	12.843	5.648	-37.515	12.625	0	0	0.218	0.218
5.559	-28.473	12.835	5.559	-28.473	12.625	0	0	0.21	0.21
5.792	-17.505	12.811	5.792	-17.505	12.625	0	0	0.186	0.186
-6.199	-16.943	12.7	-6.199	-16.943	12.625	0	0	0.075	0.075
-6.322	-27.346	12.733	-6.322	-27.346	12.625	0	0	0.108	0.108
-6.348	-36.165	12.739	-6.348	-36.165	12.625	0	0	0.114	0.114
-5.894	-47.917	12.821	-5.894	-47.917	12.625	0	0	0.196	0.196
62.935	-85.813	0.206	62.935	-85.813	0	0	0	0.206	0.206
51.506	-86.178	0.096	51.506	-86.178	0	0	0	0.096	0.096
30.76	-85.692	-0.008	30.76	-85.692	0	0	0	-0.008	-0.008
26.779	-77.972	-0.046	26.779	-77.972	0	0	0	-0.046	-0.046
39.964	-79.702	-0.204	39.964	-79.702	0	0	0	-0.204	-0.204
56.4	-76.319	-0.08	56.4	-76.319	0	0	0	-0.08	-0.08

61.054	-67.022	-0.233	61.054	-67.022	0	0	0	-0.233	-0.233
47.061	-70.268	-0.386	47.061	-70.268	0	0	0	-0.386	-0.386
37.543	-65.869	-0.303	37.543	-65.869	0	0	0	-0.303	-0.303
23.893	-65.536	-0.109	23.893	-65.536	0	0	0	-0.109	-0.109
19.936	-53.432	-0.083	19.936	-53.432	0	0	0	-0.083	-0.083
15.17	-46.304	-0.099	15.17	-46.304	0	0	0	-0.099	-0.099
23.58	-45.561	-0.159	23.58	-45.561	0	0	0	-0.159	-0.159
14.824	-35.37	-0.126	14.824	-35.37	0	0	0	-0.126	-0.126
15.691	-25.409	-0.073	15.691	-25.409	0	0	0	-0.073	-0.073
25.603	-28.35	-0.081	25.603	-28.35	0	0	0	-0.081	-0.081
33.589	-23.36	-0.019	33.589	-23.36	0	0	0	-0.019	-0.019
61.679	-24.515	0.036	61.679	-24.515	0	0	0	0.036	0.036
68.056	-35.037	0.003	68.056	-35.037	0	0	0	0.003	0.003
65.243	-55.009	0.044	65.243	-55.009	0	0	0	0.044	0.044
68.921	-6.588	0.131	68.921	-6.588	0	0	0	0.131	0.131
66.102	18.41	0.014	66.102	18.41	0	0	0	0.014	0.014
52.196	18.993	-0.399	52.196	18.993	0	0	0	-0.399	-0.399
38.319	18.748	-0.506	38.319	18.748	0	0	0	-0.506	-0.506
24.966	19.077	-0.147	24.966	19.077	0	0	0	-0.147	-0.147
27.072	28.535	-0.204	27.072	28.535	0	0	0	-0.204	-0.204
34.211	26.87	-0.293	34.211	26.87	0	0	0	-0.293	-0.293
45.953	25.93	-0.424	45.953	25.93	0	0	0	-0.424	-0.424
45.64	34.471	-0.108	45.64	34.471	0	0	0	-0.108	-0.108
29.669	39.391	-0.144	29.669	39.391	0	0	0	-0.144	-0.144
17.313	42.238	-0.349	17.313	42.238	0	0	0	-0.349	-0.349
7.071	39.371	-0.258	7.071	39.371	0	0	0	-0.258	-0.258
10.245	49.422	-0.178	10.245	49.422	0	0	0	-0.178	-0.178
22.934	52.379	-0.065	22.934	52.379	0	0	0	-0.065	-0.065
43.235	55.622	0.06	43.235	55.622	0	0	0	0.06	0.06
66.427	54.284	0.265	66.427	54.284	0	0	0	0.265	0.265
67.011	38.305	0.068	67.011	38.305	0	0	0	0.068	0.068
-12.211	40.851	-0.371	-12.211	40.851	0	0	0	-0.371	-0.371
-22.796	17.561	-0.26	-22.796	17.561	0	0	0	-0.26	-0.26
-24.095	30.752	-0.281	-24.095	30.752	0	0	0	-0.281	-0.281
-31.273	26.07	-0.29	-31.273	26.07	0	0	0	-0.29	-0.29
-43.004	26.734	-0.332	-43.004	26.734	0	0	0	-0.332	-0.332
-50.495	30.591	-0.3	-50.495	30.591	0	0	0	-0.3	-0.3
-40.445	46.138	-0.244	-40.445	46.138	0	0	0	-0.244	-0.244
-47.565	54.697	-0.082	-47.565	54.697	0	0	0	-0.082	-0.082
-75.576	53.924	0.232	-75.576	53.924	0	0	0	0.232	0.232
-75.798	37.642	0.071	-75.798	37.642	0	0	0	0.071	0.071

-74.589	19.482	-0.004	-74.589	19.482	0	0	0	-0.004	-0.004
-57.11	25.379	-0.27	-57.11	25.379	0	0	0	-0.27	-0.27
-66.153	12.076	-0.102	-66.153	12.076	0	0	0	-0.102	-0.102
-68.671	-0.983	-0.094	-68.671	-0.983	0	0	0	-0.094	-0.094
-77.027	-10.674	-0.053	-77.027	-10.674	0	0	0	-0.053	-0.053
-76.898	-29.149	-0.075	-76.898	-29.149	0	0	0	-0.075	-0.075
-62.628	-24.752	-0.159	-62.628	-24.752	0	0	0	-0.159	-0.159
-49.941	-21.794	-0.206	-49.941	-21.794	0	0	0	-0.206	-0.206
-35.614	-26.5	-0.189	-35.614	-26.5	0	0	0	-0.189	-0.189
-22.857	-18.022	-0.274	-22.857	-18.022	0	0	0	-0.274	-0.274
-27.876	-36.964	-0.218	-27.876	-36.964	0	0	0	-0.218	-0.218
-13.752	-51.052	-0.205	-13.752	-51.052	0	0	0	-0.205	-0.205
-5.255	-60.11	-0.338	-5.255	-60.11	0	0	0	-0.338	-0.338
-6.494	-70.912	-0.422	-6.494	-70.912	0	0	0	-0.422	-0.422
-7.844	-86.129	-0.176	-7.844	-86.129	0	0	0	-0.176	-0.176
-27.275	-90.718	0.085	-27.275	-90.718	0	0	0	0.085	0.085
-40.965	-88.471	0.008	-40.965	-88.471	0	0	0	0.008	0.008
-53.72	-82.055	-0.068	-53.72	-82.055	0	0	0	-0.068	-0.068
-62.932	-90.675	0.086	-62.932	-90.675	0	0	0	0.086	0.086
-77.256	-85.97	0.146	-77.256	-85.97	0	0	0	0.146	0.146
-75.594	-64.397	-0.054	-75.594	-64.397	0	0	0	-0.054	-0.054
-71.98	-44.13	-0.031	-71.98	-44.13	0	0	0	-0.031	-0.031
-65.828	-56.036	-0.063	-65.828	-56.036	0	0	0	-0.063	-0.063
-62.205	-65.827	-0.074	-62.205	-65.827	0	0	0	-0.074	-0.074
-50.486	-58.769	-0.228	-50.486	-58.769	0	0	0	-0.228	-0.228
-50.245	-72.825	-0.219	-50.245	-72.825	0	0	0	-0.219	-0.219
-14.099	-37.901	-16.701	-14.099	-37.901	-16.833	0	0	0.132	0.132
-14.487	-16.503	-16.712	-14.487	-16.503	-16.833	0	0	0.121	0.121
-13.657	16.173	-16.739	-13.657	16.173	-16.833	0	0	0.094	0.094
-13.485	29.38	-16.773	-13.485	29.38	-16.833	0	0	0.06	0.06
14.577	31.632	-16.724	14.577	31.632	-16.833	0	0	0.11	0.11
15.442	23.925	-16.722	15.442	23.925	-16.833	0	0	0.111	0.111
15.701	12.235	-16.681	15.701	12.235	-16.833	0	0	0.153	0.153
59.884	4.305	-16.645	59.884	4.305	-16.833	0	0	0.188	0.188
58.321	-9.966	-16.67	58.321	-9.966	-16.833	0	0	0.163	0.163
48.826	-15.256	-16.657	48.826	-15.256	-16.833	0	0	0.176	0.176
36.419	-9.657	-16.651	36.419	-9.657	-16.833	0	0	0.183	0.183
30.646	-17.679	-16.652	30.646	-17.679	-16.833	0	0	0.181	0.181
13.19	-15.155	-16.643	13.19	-15.155	-16.833	0	0	0.19	0.19
19.479	2.821	-4.464	19.479	2.821	-4.208	0	0	-0.256	-0.256
28.867	7.225	-4.619	28.867	7.225	-4.208	0	0	-0.411	-0.411

34.391	2.965	-4.581	34.391	2.965	-4.208	0	0	-0.373	-0.373
41.147	7.344	-4.635	41.147	7.344	-4.208	0	0	-0.427	-0.427
46.371	2.158	-4.446	46.371	2.158	-4.208	0	0	-0.238	-0.238
51.97	8.373	-4.432	51.97	8.373	-4.208	0	0	-0.224	-0.224
50.793	-3.223	0.197	50.793	-3.223	0	0	0	0.197	0.197
40.271	-3.016	0.102	40.271	-3.016	0	0	0	0.102	0.102
28.579	-2.821	0.019	28.579	-2.821	0	0	0	0.019	0.019
16.891	-2.01	0.005	16.891	-2.01	0	0	0	0.005	0.005
18.507	-9.339	1.771	18.507	-9.339	1.683	0	0	0.088	0.088
24.666	-6.507	1.729	24.666	-6.507	1.683	0	0	0.045	0.045
25.776	-14.815	1.918	25.776	-14.815	1.683	0	0	0.235	0.235
18.743	-12.117	-3.995	18.743	-12.447	-3.995	0	0.33	0	-0.33
24.817	-16.803	0.389	24.59	-16.655	0.389	0.227	-0.148	0	0.271
32.954	-3.79	-4.047	32.954	-4.03	-4.047	0	0.241	0	-0.241
39.976	-3.71	-3.29	39.976	-4.03	-3.29	0	0.32	0	-0.32
52.599	-3.692	-4.557	52.599	-4.03	-4.557	0	0.338	0	-0.338
54.963	0.149	-8.826	55.248	0.058	-8.826	-0.284	0.091	0	-0.298
56.297	7.892	-9.567	56.527	7.892	-9.567	-0.231	0	0	-0.231
59.435	12.444	-0.674	59.435	12.41	-0.601	0	0.034	-0.073	-0.08
49.22	13.394	-1.626	49.22	13.228	-1.339	0	0.166	-0.287	-0.331
39.38	12.709	-1.51	39.38	12.449	-1.25	0	0.26	-0.26	-0.367

### 3D-Tol Data from CMM for Polyamide Magnesium Casting

MEAS X	MEAS Y	MEAS Z	CAD X	CAD Y	CAD Z	DIF X	DIF Y	DIF Z	TOT DIF
53.853	58.271	-5.734	53.853	58.917	-5.734	0	-0.645	0	-0.645
37.306	58.287	-5.744	37.306	58.917	-5.744	0	-0.63	0	-0.63
20.763	58.3	-5.754	20.763	58.917	-5.754	0	-0.617	0	-0.617
4.216	58.328	-5.765	4.216	58.917	-5.765	0	-0.589	0	-0.589
-12.327	58.339	-5.776	-12.327	58.917	-5.776	0	-0.577	0	-0.577
-28.873	58.34	-5.787	-28.873	58.917	-5.787	0	-0.577	0	-0.577
-45.417	58.354	-5.798	-45.417	58.917	-5.798	0	-0.563	0	-0.563
-61.963	58.425	-5.808	-61.963	58.917	-5.808	0	-0.492	0	-0.492
-79.516	41.01	-5.805	-79.958	41.01	-5.805	0.442	0	0	-0.442
-79.521	24.464	-5.788	-79.958	24.464	-5.788	0.437	0	0	-0.437
-79.502	7.92	-5.774	-79.958	7.92	-5.774	0.457	0	0	-0.457
-79.479	-8.626	-5.76	-79.958	-8.626	-5.76	0.479	0	0	-0.479
-79.455	-25.169	-5.743	-79.958	-25.169	-5.743	0.504	0	0	-0.504
-79.459	-41.715	-5.727	-79.958	-41.715	-5.727	0.5	0	0	-0.5
-79.475	-58.26	-5.714	-79.958	-58.26	-5.714	0.483	0	0	-0.483

-79.518	-74.806	-5.699	-79.958	-74.806	-5.699	0.44	0	0	-0.44
-61.927	-92.109	-5.668	-61.927	-92.583	-5.668	0	0.475	0	-0.475
-45.383	-92.06	-5.657	-45.383	-92.583	-5.657	0	0.523	0	-0.523
-28.837	-91.938	-5.647	-28.837	-92.583	-5.647	0	0.645	0	-0.645
-12.292	-92.005	-5.636	-12.292	-92.583	-5.636	0	0.578	0	-0.578
4.251	-91.977	-5.625	4.251	-92.583	-5.625	0	0.606	0	-0.606
20.796	-91.983	-5.615	20.796	-92.583	-5.615	0	0.601	0	-0.601
37.341	-91.994	-5.604	37.341	-92.583	-5.604	0	0.59	0	-0.59
53.885	-92.085	-5.593	53.885	-92.583	-5.593	0	0.498	0	-0.498
70.811	-74.772	-5.599	71.542	-74.772	-5.599	-0.73	0	0	-0.73
70.803	-58.227	-5.614	71.542	-58.227	-5.614	-0.739	0	0	-0.739
70.82	-41.683	-5.629	71.542	-41.683	-5.629	-0.722	0	0	-0.722
70.807	-25.138	-5.644	71.542	-25.138	-5.644	-0.735	0	0	-0.735
70.65	-8.593	-5.659	71.542	-8.593	-5.659	-0.892	0	0	-0.892
70.632	7.951	-5.675	71.542	7.951	-5.675	-0.91	0	0	-0.91
70.77	24.497	-5.688	71.542	24.497	-5.688	-0.772	0	0	-0.772
70.858	41.041	-5.704	71.542	41.041	-5.704	-0.684	0	0	-0.684
-69.709	43.719	8.356	-69.709	43.719	8.417	0	0	-0.061	-0.061
-64.66	43.721	8.379	-64.66	43.721	8.417	0	0	-0.038	-0.038
-64.661	48.771	8.314	-64.661	48.771	8.417	0	0	-0.103	-0.103
-69.713	48.77	8.323	-69.713	48.77	8.417	0	0	-0.093	-0.093
-67.581	46.363	8.276	-67.581	46.363	8.417	0	0	-0.141	-0.141
-71.467	43.715	6.823	-71.542	43.715	6.823	0.074	0	0	-0.074
-71.523	48.765	6.818	-71.542	48.765	6.818	0.019	0	0	-0.019
-69.709	50.567	6.818	-69.709	50.5	6.818	0	0.067	0	0.067
-64.659	50.473	6.823	-64.659	50.5	6.823	0	-0.027	0	-0.027
-63.683	42.017	6.833	-63.125	42.083	6.833	-0.558	-0.066	0	0.562
-69.707	41.999	7.801	-69.707	42.083	8.417	0	-0.084	-0.615	0.621
-63.014	48.768	7.792	-63.125	48.768	8.417	0.111	0	-0.625	0.634
-63.03	43.719	7.801	-63.125	43.719	8.417	0.095	0	-0.615	0.623
-64.644	-14.359	4.109	-64.644	-14.359	4.208	0	0	-0.1	-0.1
-69.697	-14.359	4.169	-69.697	-14.359	4.208	0	0	-0.039	-0.039
-69.695	-19.409	4.227	-69.695	-19.409	4.208	0	0	0.019	0.019
-64.645	-19.408	4.186	-64.645	-19.408	4.208	0	0	-0.022	-0.022
-67.817	-16.787	4.112	-67.817	-16.787	4.208	0	0	-0.097	-0.097
-69.695	-12.623	4.207	-69.695	-12.625	4.208	0	0.002	-0.002	0.002
-64.645	-12.657	4.244	-64.645	-12.625	4.208	0	-0.032	0.035	-0.047
-63.212	-14.36	4.429	-63.125	-14.36	4.208	-0.087	0	0.221	-0.238
-63.221	-19.41	4.403	-63.125	-19.41	4.208	-0.096	0	0.194	-0.217
-64.642	-21.017	4.235	-64.642	-21.042	4.208	0	0.025	0.026	-0.036
-69.692	-21.036	4.214	-69.692	-21.042	4.208	0	0.006	0.006	-0.008

-71.622	-19.414	3.514	-71.542	-19.414	3.514	-0.081	0	0	0.081
-71.573	-14.362	3.509	-71.542	-14.362	3.509	-0.031	0	0	0.031
-64.635	-77.479	8.522	-64.635	-77.479	8.417	0	0	0.105	0.105
-69.687	-77.481	8.515	-69.687	-77.481	8.417	0	0	0.098	0.098
-69.684	-82.531	8.543	-69.684	-82.531	8.417	0	0	0.126	0.126
-64.635	-82.529	8.542	-64.635	-82.529	8.417	0	0	0.125	0.125
-69.684	-75.658	7.9	-69.684	-75.75	8.417	0	0.092	-0.517	0.525
-64.634	-75.704	7.914	-64.634	-75.75	8.417	0	0.046	-0.502	0.504
-63.083	-77.481	7.919	-63.125	-77.481	8.417	0.042	0	-0.498	0.5
-63.047	-82.532	7.916	-63.125	-82.532	8.417	0.078	0	-0.5	0.507
-64.63	-84.016	6.947	-64.63	-84.167	6.947	0	0.151	0	-0.151
-69.682	-84.043	6.943	-69.682	-84.167	6.943	0	0.124	0	-0.124
-71.517	-82.536	6.937	-71.542	-82.536	6.937	0.025	0	0	-0.025
-71.39	-77.484	6.932	-71.542	-77.484	6.932	0.151	0	0	-0.151
-2.375	43.73	4.279	-2.375	43.73	4.208	0	0	0.071	0.071
2.677	43.731	4.337	2.677	43.731	4.208	0	0	0.129	0.129
2.674	48.782	4.407	2.674	48.782	4.208	0	0	0.199	0.199
-2.377	48.779	4.337	-2.377	48.779	4.208	0	0	0.129	0.129
-0.536	46.764	4.346	-0.536	46.764	4.208	0	0	0.138	0.138
-4.076	43.724	2.238	-4.208	43.724	2.238	0.132	0	0	-0.132
-4.064	48.775	2.234	-4.208	48.775	2.234	0.144	0	0	-0.144
2.681	42.476	2.247	2.681	42.083	2.247	0	0.393	0	-0.393
-2.371	42.495	2.245	-2.371	42.083	2.245	0	0.411	0	-0.411
3.888	48.778	2.242	4.208	48.778	2.242	-0.32	0	0	-0.32
3.877	43.728	2.247	4.208	43.728	2.247	-0.331	0	0	-0.331
-2.373	50.495	2.233	-2.373	50.5	2.233	0	-0.005	0	-0.005
2.676	50.538	2.238	2.676	50.5	2.238	0	0.038	0	0.038
-64.647	36.183	-0.265	-64.732	36.268	0	0.085	-0.085	-0.265	0.291
-53.938	46.897	-0.263	-54.021	46.979	0	0.082	-0.082	-0.263	0.287
-46.751	46.898	-1.157	-46.825	46.825	-1.157	0.074	0.074	0	-0.104
-36.045	36.178	-1.141	-36.112	36.112	-1.141	0.067	0.067	0	-0.094
-40.98	28.862	-1.136	-40.872	28.97	-1.136	-0.108	-0.108	0	-0.152
-48.154	35.976	-1.147	-48.017	36.114	-1.147	-0.138	-0.138	0	-0.195
-35.772	29.714	-1.518	-35.675	29.616	-1.518	-0.097	0.097	0	0.138
-54.182	35.234	-1.155	-54.022	35.075	-1.155	-0.159	0.159	0	0.225
-58.956	30.491	-1.153	-58.781	30.316	-1.153	-0.175	0.175	0	0.247
-65.39	29.404	-1.054	-65.251	29.542	-1.054	-0.138	-0.138	0	-0.196
-61.238	33.504	-4.01	-61.238	33.504	-4.208	0	0	0.198	0.198
-56.67	38.258	-4.016	-56.67	38.258	-4.208	0	0	0.192	0.192
-50.175	43.664	-4.026	-50.175	43.664	-4.208	0	0	0.183	0.183
-44.615	38.616	-4.064	-44.615	38.616	-4.208	0	0	0.144	0.144

-39.937	33.809	-4.08	-39.937	33.809	-4.208	0	0	0.128	0.128
49.812	42.339	6.065	49.812	42.083	6.065	0	0.256	0	-0.256
43.077	42.449	6.061	43.077	42.083	6.061	0	0.365	0	-0.365
55.016	30.273	6.078	54.708	30.273	6.078	0.308	0	0	-0.308
55.02	37.007	6.07	54.708	37.007	6.07	0.311	0	0	-0.311
58.955	25.518	5.592	58.955	25.25	5.592	0	0.268	0	-0.268
62.824	30.277	6.085	63.125	30.277	6.085	-0.301	0	0	-0.301
62.853	37.852	6.078	63.125	37.852	6.078	-0.272	0	0	-0.272
62.899	45.427	6.07	63.125	45.427	6.07	-0.226	0	0	-0.226
58.224	50.188	6.06	58.224	50.5	6.06	0	-0.312	0	-0.312
50.648	50.209	6.055	50.648	50.5	6.055	0	-0.291	0	-0.291
43.071	50.213	6.05	43.071	50.5	6.05	0	-0.287	0	-0.287
38.285	46.212	5.333	37.875	46.212	5.333	0.41	0	0	-0.41
43.323	46.387	8.559	43.323	46.387	8.417	0	0	0.142	0.142
50.555	46.099	8.517	50.555	46.099	8.417	0	0	0.1	0.1
58.525	45.768	8.592	58.525	45.768	8.417	0	0	0.175	0.175
59.268	37.504	8.49	59.268	37.504	8.417	0	0	0.073	0.073
59.145	30.659	8.38	59.145	30.659	8.417	0	0	-0.037	-0.037
-30.759	49.202	16.866	-30.759	48.909	17.035	0	0.293	-0.169	-0.338
-30.755	46.156	11.924	-30.755	46.008	12.01	0	0.149	-0.086	-0.172
-30.752	43.301	6.869	-30.752	43.105	6.982	0	0.196	-0.113	-0.226
-30.748	40.411	1.836	-30.748	40.203	1.956	0	0.208	-0.12	-0.24
-26.959	40.419	1.835	-26.959	40.205	1.959	0	0.215	-0.124	-0.248
-26.965	43.322	6.858	-26.965	43.106	6.983	0	0.216	-0.125	-0.25
-26.969	46.302	11.841	-26.969	46.008	12.011	0	0.294	-0.169	-0.339
-26.973	49.149	16.9	-26.973	48.91	17.037	0	0.238	-0.138	-0.275
-23.183	49.052	16.957	-23.183	48.911	17.039	0	0.141	-0.081	-0.163
-23.18	46.123	11.949	-23.18	46.01	12.014	0	0.113	-0.065	-0.13
-23.176	43.304	6.87	-23.176	43.106	6.984	0	0.198	-0.114	-0.229
-23.171	40.415	1.84	-23.171	40.206	1.961	0	0.209	-0.121	-0.242
-16.86	45.711	1.918	-16.86	45.439	1.991	0	0.272	-0.073	-0.281
-16.868	47.564	9.504	-16.868	47.459	9.532	0	0.105	-0.028	-0.108
-16.873	49.618	17.032	-16.873	49.479	17.069	0	0.14	-0.037	-0.144
-11.821	49.472	17.075	-11.821	49.48	17.073	0	-0.008	0.002	0.009
-11.815	47.532	9.517	-11.815	47.46	9.536	0	0.072	-0.019	-0.074
-11.81	45.708	1.924	-11.81	45.44	1.995	0	0.268	-0.072	-0.278
-8.78	49.58	7.655	-8.178	49.58	7.655	-0.602	0	0	-0.602
-30.76	50.87	15.172	-30.76	50.935	15.19	0	-0.065	-0.017	-0.067
-30.76	52.489	9.547	-30.76	52.45	9.537	0	0.039	0.01	0.041
-30.756	54.073	3.91	-30.756	53.965	3.881	0	0.107	0.029	0.111
-24.02	53.941	3.878	-24.02	53.964	3.884	0	-0.024	-0.006	-0.025

-24.026	52.388	9.525	-24.026	52.449	9.541	0	-0.061	-0.016	-0.063
-24.029	50.83	15.165	-24.029	50.934	15.193	0	-0.105	-0.028	-0.108
-17.293	50.719	15.141	-17.293	50.933	15.198	0	-0.214	-0.057	-0.222
-17.292	52.333	9.515	-17.292	52.447	9.546	0	-0.114	-0.031	-0.118
-17.289	53.931	3.88	-17.289	53.963	3.888	0	-0.032	-0.009	-0.033
-10.553	53.923	3.882	-10.553	53.962	3.893	0	-0.039	-0.011	-0.041
-10.56	52.3	9.51	-10.56	52.446	9.55	0	-0.146	-0.039	-0.152
-10.562	50.618	15.119	-10.562	50.931	15.203	0	-0.314	-0.084	-0.325
-33.058	48.919	9.781	-33.428	48.919	9.781	0.37	0	0	-0.37
5.063	-63.152	19.128	5.121	-63.152	19.112	-0.058	0	0.016	0.06
3.335	-63.158	12.012	3.227	-63.158	12.041	0.108	0	-0.029	-0.112
1.423	-63.164	4.95	1.333	-63.164	4.974	0.09	0	-0.024	-0.093
1.564	-69.898	4.919	1.334	-69.898	4.98	0.23	0	-0.061	-0.238
3.494	-69.889	11.976	3.228	-69.889	12.048	0.266	0	-0.071	-0.275
5.065	-69.883	19.132	5.122	-69.883	19.117	-0.058	0	0.015	0.06
5.075	-76.617	19.136	5.124	-76.617	19.123	-0.048	0	0.013	0.05
3.545	-76.624	11.968	3.23	-76.624	12.053	0.316	0	-0.085	-0.327
1.671	-76.631	4.897	1.336	-76.631	4.986	0.335	0	-0.09	-0.346
1.417	-83.365	4.973	1.338	-83.365	4.994	0.079	0	-0.021	-0.082
3.259	-83.356	12.051	3.231	-83.356	12.059	0.028	0	-0.008	-0.029
5.177	-83.35	19.114	5.125	-83.35	19.128	0.052	0	-0.014	-0.054
7.635	-85.445	10.625	7.635	-85.85	10.625	0	0.405	0	-0.405
7.383	-83.346	21.197	7.603	-83.346	21.323	-0.22	0	-0.127	-0.254
12.826	-83.353	11.776	13.043	-83.353	11.901	-0.217	0	-0.125	-0.251
18.387	-83.36	2.423	18.483	-83.36	2.478	-0.096	0	-0.055	-0.111
18.389	-75.785	2.419	18.485	-75.785	2.474	-0.097	0	-0.056	-0.112
12.774	-75.778	11.741	13.045	-75.778	11.898	-0.271	0	-0.157	-0.313
7.322	-75.77	21.155	7.605	-75.77	21.319	-0.284	0	-0.164	-0.328
6.591	-69.457	21.311	6.893	-69.457	21.391	-0.302	0	-0.081	-0.312
9.176	-69.466	11.899	9.419	-69.466	11.965	-0.243	0	-0.065	-0.252
11.773	-69.474	2.498	11.943	-69.474	2.544	-0.171	0	-0.046	-0.177
11.761	-64.423	2.492	11.944	-64.423	2.541	-0.184	0	-0.049	-0.19
9.149	-64.416	11.89	9.42	-64.416	11.963	-0.27	0	-0.072	-0.28
6.612	-64.408	21.314	6.894	-64.408	21.389	-0.282	0	-0.075	-0.291
6.612	-61.379	11.347	6.612	-60.6	11.347	0	-0.779	0	-0.779
-30.349	-50.461	-5.219	-30.355	-50.358	-5.324	0.005	-0.102	0.105	0.147
-30.052	-55.126	-7.617	-30.057	-55.024	-7.814	0.005	-0.102	0.197	0.222
-29.811	-58.658	-11.373	-29.819	-58.481	-11.468	0.007	-0.177	0.095	0.201
-29.62	-61.603	-15.612	-29.624	-61.459	-15.803	0.004	-0.144	0.191	0.24
-33.678	-63.439	-15.806	-33.712	-63.408	-15.869	0.034	-0.031	0.063	0.078
-35.975	-61.377	-11.504	-35.982	-61.371	-11.509	0.007	-0.006	0.005	0.011

-38.484	-59.136	-7.751	-38.525	-59.1	-7.854	0.041	-0.037	0.103	0.117
-41.995	-55.992	-5.375	-42.009	-55.979	-5.395	0.014	-0.013	0.02	0.028
-46.427	-68.183	-5.467	-46.361	-68.18	-5.396	-0.066	-0.003	-0.071	-0.097
-41.671	-67.963	-7.828	-41.686	-67.964	-7.856	0.015	0.001	0.028	0.032
-38.488	-67.825	-11.62	-38.282	-67.814	-11.51	-0.206	-0.011	-0.11	-0.234
-35.278	-67.681	-15.932	-35.234	-67.678	-15.87	-0.044	-0.003	-0.061	-0.075
-33.362	-71.835	-15.927	-33.304	-71.768	-15.809	-0.058	-0.067	-0.118	-0.148
-35.526	-74.161	-11.608	-35.345	-73.958	-11.463	-0.181	-0.203	-0.145	-0.308
-37.71	-76.493	-7.836	-37.704	-76.486	-7.817	-0.007	-0.007	-0.019	-0.022
-40.96	-79.991	-5.445	-40.886	-79.909	-5.331	-0.075	-0.082	-0.114	-0.159
-29.567	-67.426	-16.719	-29.553	-67.414	-16.851	-0.014	-0.012	0.132	0.134
-26.49	-62.349	-15.517	-26.403	-62.204	-15.731	-0.087	-0.145	0.214	0.273
-25.127	-59.848	-11.296	-25.009	-59.644	-11.422	-0.118	-0.204	0.126	0.267
-23.384	-56.61	-7.619	-23.345	-56.542	-7.773	-0.039	-0.068	0.154	0.173
-21.164	-52.539	-5.132	-21.107	-52.438	-5.246	-0.057	-0.102	0.114	0.163
-13.048	-62.624	-5.076	-12.963	-62.6	-5.158	-0.085	-0.024	0.082	0.121
-17.53	-63.943	-7.55	-17.444	-63.919	-7.73	-0.086	-0.024	0.179	0.2
-21.04	-64.986	-11.276	-20.873	-64.94	-11.369	-0.167	-0.047	0.093	0.197
-23.743	-65.786	-15.47	-23.599	-65.747	-15.65	-0.144	-0.039	0.181	0.234
-24.13	-70.2	-15.589	-24.096	-70.219	-15.635	-0.034	0.018	0.046	0.06
-21.494	-71.636	-11.04	-21.466	-71.651	-11.058	-0.028	0.015	0.018	0.036
-18.506	-73.268	-7.606	-18.457	-73.294	-7.718	-0.049	0.027	0.113	0.126
-14.378	-75.517	-5.126	-14.363	-75.526	-5.143	-0.015	0.008	0.016	0.024
-24.467	-83.749	-5.238	-24.478	-83.712	-5.202	0.011	-0.036	-0.036	-0.052
-25.806	-79.19	-7.656	-25.792	-79.235	-7.748	-0.014	0.044	0.092	0.103
-26.739	-75.969	-11.465	-26.784	-75.826	-11.385	0.045	-0.143	-0.081	-0.17
-27.577	-73.103	-15.752	-27.592	-73.057	-15.691	0.015	-0.046	-0.06	-0.078
-32.354	-72.57	-15.884	-32.289	-72.516	-15.782	-0.064	-0.054	-0.102	-0.132
-33.886	-75.287	-11.567	-33.712	-75.12	-11.444	-0.174	-0.167	-0.123	-0.271
-35.202	-78.255	-7.777	-35.208	-78.265	-7.8	0.006	0.01	0.023	0.026
-37.687	-82.337	-5.391	-37.619	-82.272	-5.301	-0.068	-0.064	-0.09	-0.13
-25.227	-86.373	-0.511	-25.231	-86.355	-0.485	0.004	-0.018	-0.025	-0.031
-12.914	-77.206	-0.553	-12.867	-77.234	-0.616	-0.047	0.028	0.063	0.084
-10.969	-61.843	-0.533	-10.916	-61.827	-0.598	-0.053	-0.016	0.065	0.085
-15.961	-53.613	-0.507	-15.901	-53.552	-0.607	-0.06	-0.061	0.1	0.131
-25.615	-48.301	-0.464	-25.608	-48.267	-0.511	-0.007	-0.035	0.047	0.058
-47.493	-37.961	18.84	-47.213	-37.836	19.017	-0.28	-0.125	-0.177	-0.354
-44.108	-36.375	12.579	-43.913	-36.286	12.703	-0.195	-0.089	-0.124	-0.247
-40.861	-34.849	6.235	-40.615	-34.736	6.391	-0.246	-0.114	-0.157	-0.313
-40.042	-41.278	6.231	-39.793	-41.325	6.377	-0.249	0.047	-0.146	-0.292
-43.588	-40.607	12.565	-43.375	-40.647	12.69	-0.213	0.04	-0.125	-0.25

-47.213	-39.923	18.857	-46.959	-39.971	19.007	-0.255	0.048	-0.15	-0.299
-48.135	-41.698	18.888	-47.974	-41.861	19.02	-0.161	0.163	-0.132	-0.264
-45.543	-44.429	12.641	-45.466	-44.508	12.704	-0.077	0.079	-0.064	-0.127
-43.04	-47.076	6.328	-42.963	-47.157	6.392	-0.077	0.08	-0.064	-0.129
-48.953	-50.112	6.458	-48.96	-50.058	6.426	0.008	-0.054	0.031	0.063
-49.431	-46.481	12.76	-49.436	-46.444	12.739	0.005	-0.036	0.021	0.042
-49.933	-42.732	18.997	-49.917	-42.83	19.054	-0.016	0.097	-0.057	-0.114
-52.175	-42.323	19.041	-52.203	-42.418	19.097	0.029	0.095	-0.056	-0.114
-53.885	-45.801	12.86	-53.824	-45.684	12.784	-0.061	-0.117	0.076	0.152
-55.645	-49.039	6.569	-55.564	-48.887	6.47	-0.08	-0.152	0.099	0.198
-50.732	-39.435	22.289	-51.666	-39.979	22.914	0.934	0.544	-0.624	-1.248
-57.098	-42.531	12.911	-56.948	-42.458	12.815	-0.15	-0.073	0.096	0.193
-62.457	-45.088	2.874	-62.21	-44.969	2.715	-0.246	-0.119	0.158	0.316
-63.475	-36.879	2.841	-63.283	-36.915	2.727	-0.193	0.036	0.113	0.226
-57.697	-37.955	12.917	-57.548	-37.982	12.83	-0.149	0.028	0.087	0.175
-51.222	-39.932	23.127	-51.049	-40.305	23.268	-0.174	0.372	-0.141	0.434
-50.266	-38.312	23.091	-49.934	-38.265	23.206	-0.332	-0.047	-0.116	0.354
-55.414	-33.977	12.857	-55.368	-34.026	12.819	-0.046	0.049	0.039	0.078
-59.414	-29.74	2.749	-59.373	-29.784	2.714	-0.041	0.044	0.035	0.069
-52.007	-26.446	2.628	-52.018	-26.358	2.679	0.01	-0.089	-0.052	-0.103
-51.28	-32.18	12.759	-51.284	-32.144	12.78	0.004	-0.037	-0.021	-0.042
-50.498	-39.023	22.248	-50.489	-37.931	22.878	-0.009	-1.092	-0.631	-1.261
-50.307	-39.036	22.22	-49.679	-38.174	22.836	-0.629	-0.862	-0.616	-1.232
-47.128	-33.062	12.663	-47.037	-32.961	12.739	-0.091	-0.101	-0.076	-0.156
-44.377	-27.986	2.528	-44.241	-27.843	2.638	-0.136	-0.143	-0.11	-0.226
-46.223	4.029	25.081	-46.143	3.951	25.191	-0.081	0.079	-0.11	-0.157
-50.202	7.769	27.616	-50.188	7.756	27.551	-0.013	0.013	0.066	0.068
-53.796	11.16	22.123	-53.644	11.016	22.03	-0.152	0.145	0.093	0.23
-56.551	13.755	8.464	-56.377	13.59	8.42	-0.174	0.165	0.044	0.244
-61.996	-1.676	8.48	-61.735	-1.654	8.432	-0.261	-0.022	0.048	0.267
-58.227	-1.356	22.15	-57.99	-1.336	22.044	-0.238	-0.02	0.106	0.261
-53.275	-0.947	27.656	-53.247	-0.945	27.554	-0.028	-0.002	0.102	0.105
-47.818	-0.512	25.083	-47.717	-0.503	25.182	-0.101	-0.009	-0.099	-0.142
-45.448	-4.664	25.167	-45.415	-4.619	25.222	-0.033	-0.045	-0.055	-0.078
-48.82	-9.039	27.611	-48.808	-9.022	27.541	-0.012	-0.017	0.07	0.073
-51.731	-12.86	22.078	-51.666	-12.774	22.029	-0.065	-0.087	0.048	0.119
-53.982	-15.835	8.45	-53.93	-15.766	8.434	-0.052	-0.069	0.016	0.088
-38.315	-19.251	8.405	-38.295	-19.355	8.425	-0.02	0.104	-0.02	-0.108
-39.007	-15.623	21.969	-38.995	-15.682	21.996	-0.012	0.059	-0.027	-0.066
-39.852	-11.127	27.549	-39.854	-11.116	27.515	0.002	-0.011	0.034	0.036
-40.878	-5.558	25.345	-40.865	-5.622	25.28	-0.014	0.064	0.065	0.092

-40.179	19.643	8.407	-40.18	19.634	8.405	0.001	0.009	0.002	0.01
-40.518	15.95	22.018	-40.522	15.906	21.998	0.004	0.044	0.02	0.048
-40.937	11.247	27.562	-40.938	11.236	27.528	0.001	0.01	0.034	0.035
-41.408	5.686	25.236	-41.409	5.678	25.245	0.001	0.009	-0.009	-0.012
-38.506	4.442	25.333	-38.474	4.482	25.282	-0.032	-0.04	0.051	0.072
-35.105	8.947	27.495	-35.102	8.951	27.51	-0.003	-0.004	-0.015	-0.016
-32.341	12.577	21.937	-32.29	12.644	21.974	-0.052	-0.067	-0.037	-0.092
-30.093	15.498	8.375	-30.012	15.602	8.399	-0.081	-0.104	-0.024	-0.134
-23.764	6.742	8.362	-23.57	6.813	8.4	-0.194	-0.071	-0.038	-0.21
-27.257	5.454	21.872	-27.068	5.523	21.961	-0.189	-0.069	-0.089	-0.22
-31.411	3.909	27.411	-31.384	3.919	27.496	-0.027	-0.01	-0.085	-0.09
-36.725	1.913	25.404	-36.637	1.944	25.311	-0.088	-0.031	0.093	0.132
-36.522	-1.15	25.437	-36.409	-1.173	25.322	-0.113	0.023	0.115	0.163
-30.942	-2.31	27.404	-30.913	-2.316	27.491	-0.029	0.006	-0.088	-0.093
-26.633	-3.208	21.862	-26.418	-3.253	21.959	-0.216	0.045	-0.097	-0.241
-23.073	-3.959	8.348	-22.772	-4.022	8.404	-0.301	0.063	-0.057	-0.313
-28.002	-13.475	8.369	-27.832	-13.637	8.412	-0.169	0.162	-0.043	-0.239
-30.64	-10.926	21.896	-30.515	-11.045	21.972	-0.125	0.119	-0.076	-0.188
-33.845	-7.83	27.438	-33.83	-7.844	27.499	-0.015	0.014	-0.061	-0.064
-37.929	-3.875	25.413	-37.854	-3.945	25.311	-0.075	0.07	0.102	0.144
-41.97	5.742	25.208	-41.971	5.711	25.239	0.001	0.031	-0.031	-0.044
-42.048	11.302	27.582	-42.048	11.286	27.531	0	0.016	0.052	0.054
-42.093	16.058	22.034	-42.093	15.982	22	0	0.077	0.034	0.084
-42.118	19.775	8.416	-42.118	19.726	8.407	0	0.049	0.009	0.05
-40.677	1.182	20.443	-40.546	1.292	20.337	-0.131	-0.11	0.107	0.202
-45.131	0.241	21.57	-44.957	0.228	21.687	-0.174	0.014	-0.118	-0.21
-40.691	-2.212	21.635	-40.605	-2.349	21.528	-0.086	0.136	0.108	0.194
45.104	-41.161	14.853	45.145	-41.232	15.15	-0.041	0.071	-0.297	-0.308
42.542	-45.966	13.316	42.537	-46.006	13.388	0.006	0.04	-0.072	-0.083
40.366	-49.96	9.856	40.356	-49.998	9.892	0.01	0.038	-0.036	-0.054
38.873	-52.697	5.032	38.86	-52.737	5.049	0.013	0.04	-0.017	-0.045
32.03	-44.796	5.008	31.893	-44.851	5.071	0.137	0.054	-0.063	-0.16
34.953	-43.651	9.796	34.821	-43.704	9.928	0.132	0.053	-0.132	-0.194
39.181	-41.993	13.218	39.083	-42.032	13.42	0.098	0.039	-0.203	-0.228
44.199	-40.029	14.881	44.163	-40.044	15.161	0.036	0.015	-0.28	-0.282
44.136	-38.37	15.044	44.121	-38.365	15.163	0.015	-0.005	-0.118	-0.12
39.063	-36.66	13.189	38.948	-36.621	13.425	0.116	-0.04	-0.235	-0.265
34.761	-35.215	9.78	34.604	-35.162	9.933	0.157	-0.053	-0.154	-0.226
31.821	-34.227	4.979	31.619	-34.158	5.07	0.202	-0.069	-0.091	-0.232
38.453	-26.037	4.947	38.329	-25.832	5.049	0.123	-0.206	-0.102	-0.261
40.029	-28.627	9.779	39.959	-28.509	9.906	0.071	-0.119	-0.128	-0.188

42.37	-32.464	13.266	42.334	-32.403	13.401	0.036	-0.061	-0.135	-0.153
45.186	-37.086	14.922	45.17	-37.057	15.155	0.016	-0.029	-0.233	-0.236
46.804	-36.774	14.822	46.814	-36.728	15.14	-0.01	-0.046	-0.318	-0.321
47.621	-31.413	13.259	47.63	-31.361	13.359	-0.009	-0.052	-0.1	-0.113
48.302	-26.946	9.797	48.312	-26.883	9.855	-0.01	-0.063	-0.058	-0.086
48.765	-23.932	4.967	48.784	-23.818	5.016	-0.019	-0.114	-0.049	-0.126
38.873	-52.696	5.032	38.86	-52.737	5.049	0.013	0.04	-0.018	-0.046
40.366	-49.961	9.857	40.356	-49.999	9.892	0.01	0.038	-0.035	-0.053
42.543	-45.966	13.316	42.537	-46.006	13.388	0.006	0.04	-0.072	-0.083
45.104	-41.161	14.853	45.145	-41.232	15.15	-0.041	0.071	-0.297	-0.308
47.414	-36.938	14.842	47.494	-36.931	15.133	-0.08	-0.006	-0.292	-0.302
50.07	-32.195	13.287	50.092	-32.176	13.338	-0.021	-0.019	-0.051	-0.059
52.237	-28.238	9.807	52.255	-28.217	9.831	-0.018	-0.02	-0.024	-0.036
53.681	-25.573	4.966	53.734	-25.51	5	-0.052	-0.063	-0.034	-0.089
60.696	-33.586	4.941	60.785	-33.552	4.981	-0.089	-0.034	-0.04	-0.103
57.853	-34.695	9.718	57.933	-34.665	9.796	-0.08	-0.031	-0.078	-0.116
53.686	-36.32	13.172	53.754	-36.294	13.307	-0.068	-0.026	-0.135	-0.154
48.678	-38.275	14.8	48.725	-38.258	15.121	-0.047	-0.017	-0.321	-0.325
48.72	-39.918	14.81	48.766	-39.932	15.119	-0.046	0.015	-0.309	-0.312
53.818	-41.639	13.181	53.879	-41.66	13.3	-0.061	0.02	-0.119	-0.135
58.075	-43.072	9.747	58.122	-43.088	9.791	-0.046	0.016	-0.044	-0.066
61.021	-44.071	4.983	61.017	-44.069	4.981	0.004	-0.001	0.002	0.005
54.516	-52.392	5.037	54.473	-52.323	5.003	0.043	-0.069	0.034	0.088
52.876	-49.706	9.828	52.872	-49.699	9.82	0.004	-0.007	0.008	0.011
50.514	-45.826	13.262	50.533	-45.855	13.326	-0.018	0.029	-0.064	-0.072
47.693	-41.199	14.811	47.72	-41.239	15.128	-0.027	0.04	-0.316	-0.32
45.37	-41.205	15.283	45.215	-41.103	15.171	0.155	-0.102	0.112	0.216
45.267	-46.913	13.313	45.263	-46.94	13.365	0.004	0.027	-0.052	-0.059
44.583	-51.418	9.868	44.583	-51.418	9.868	0	0	0	0
44.12	-54.502	5.041	44.122	-54.488	5.035	-0.002	-0.014	0.006	0.015
53.683	-25.572	4.969	53.733	-25.511	5.001	-0.051	-0.061	-0.033	-0.086
52.238	-28.237	9.807	52.255	-28.217	9.83	-0.017	-0.02	-0.023	-0.035
50.069	-32.197	13.286	50.091	-32.177	13.339	-0.022	-0.02	-0.053	-0.061
47.414	-36.939	14.841	47.494	-36.932	15.133	-0.08	-0.007	-0.292	-0.303
32.549	-49.581	0.517	32.505	-49.615	0.583	0.044	0.033	-0.066	-0.086
36.864	-53.912	0.407	36.859	-53.919	0.42	0.005	0.007	-0.013	-0.015
45.346	-56.252	0.882	45.35	-56.18	0.816	-0.004	-0.072	0.066	0.098
54.644	-53.966	1.094	54.589	-53.869	1.011	0.055	-0.097	0.083	0.139
60.886	-47.72	1.169	60.808	-47.674	1.108	0.078	-0.046	0.061	0.109
63.138	-39.418	1.091	63.142	-39.418	1.093	-0.004	0	-0.003	-0.004
5.665	29.386	-10.382	5.665	29.435	-10.368	0	-0.049	-0.015	-0.051

2.296	29.349	-10.394		2.296	29.435	-10.368		0	-0.086	-0.026		-0.089
2.292	26.097	0.099		2.292	26.279	0.153		0	-0.182	-0.054		-0.19
-1.07	29.395	-10.383		-1.07	29.436	-10.371		0	-0.041	-0.012		-0.043
5.67	20.213	-12.536		5.67	20.053	-12.488		0	0.16	-0.048		-0.167
2.296	23.373	-2.016		2.296	23.209	-1.967		0	0.163	-0.049		-0.171
2.305	20.262	-12.554		2.305	20.052	-12.491		0	0.21	-0.063		-0.219
-1.064	20.246	-12.551		-1.064	20.052	-12.493		0	0.194	-0.058		-0.203
7.916	27.538	-10.475		7.995	27.538	-10.443		-0.08	0	-0.032		-0.086
7.888	25.013	-10.483		7.994	25.013	-10.44		-0.107	0	-0.043		-0.115
3.554	25.021	-0.013		3.786	25.021	0.08		-0.233	0	-0.093		-0.25
7.915	22.488	-10.471		7.994	22.488	-10.439		-0.079	0	-0.032		-0.085
-4.417	27.532	-12.485		-4.525	27.532	-12.441		0.108	0	-0.043		-0.116
-0.118	25.017	-1.992		-0.314	25.017	-1.913		0.196	0	-0.078		-0.211
-4.377	25.006	-12.496		-4.524	25.006	-12.438		0.146	0	-0.058		-0.157
-4.365	22.481	-12.499		-4.523	22.481	-12.436		0.157	0	-0.063		-0.169
-8.931	4.962	-1.935		-9.197	5.109	-1.935		0.265	-0.147	0		0.304
-9.076	5.049	9.85		-9.194	5.114	9.85		0.119	-0.066	0		0.136
-0.491	10.51	9.85		-0.491	10.509	9.85		0	0.001	0		-0.001
-0.472	10.333	-1.934		-0.48	10.51	-1.934		0.008	-0.177	0		0.177
8.526	6.015	-1.926		8.597	6.065	-1.926		-0.07	-0.05	0		0.086
8.707	6.166	9.858		8.586	6.08	9.858		0.121	0.086	0		-0.149
10.232	-3.301	9.866		10.013	-3.231	9.866		0.22	-0.071	0		-0.231
9.988	-3.229	1.026		10.011	-3.236	1.026		-0.023	0.007	0		0.024
0.179	-10.417	1.028		0.181	-10.519	1.028		-0.002	0.102	0		0.102
0.173	-10.584	9.867		0.172	-10.519	9.867		0.001	-0.064	0		-0.064
-9.87	-3.303	9.854		-9.977	-3.339	9.854		0.107	0.036	0		0.113
-9.69	-3.255	1.018		-9.973	-3.35	1.018		0.284	0.095	0		0.299
10.864	-10.202	3.985		10.737	-10.083	3.985		0.127	-0.119	0		0.174
-11.056	-9.605	3.966		-11.119	-9.66	3.966		0.063	0.055	0		-0.083
-14.44	1.883	1.006		-14.606	1.905	1.006		0.165	-0.022	0		-0.167
-8.219	12.14	3.946		-8.257	12.197	3.946		0.038	-0.056	0		-0.068
3.621	14.396	1.007		3.593	14.284	1.007		0.028	0.112	0		0.115
13.11	6.997	3.969		12.994	6.935	3.969		0.115	0.062	0		0.131
2.032	2.118	-16.9		2.032	2.118	-16.833		0	0	-0.067		-0.067
-3.642	3.788	-16.712		-3.642	3.788	-16.833		0	0	0.122		0.122
-3.722	-4.144	-16.71		-3.722	-4.144	-16.833		0	0	0.124		0.124
3.851	-3.997	-16.716		3.851	-3.997	-16.833		0	0	0.117		0.117
-0.195	0.157	-20.898		-0.195	0.157	-21.042		0	0	0.143		0.143
-9.235	-8.542	12.609		-9.235	-8.542	12.625		0	0	-0.016		-0.016
-11.877	3.515	12.679		-11.877	3.515	12.625		0	0	0.054		0.054
-0.805	11.998	12.689		-0.805	11.998	12.625		0	0	0.064		0.064

11.356	4.931	12.535	11.356	4.931	12.625	0	0	-0.09	-0.09
10.706	-7.009	12.479	10.706	-7.009	12.625	0	0	-0.146	-0.146
0.57	-12.817	12.555	0.57	-12.817	12.625	0	0	-0.07	-0.07
-0.313	-14.674	7.066	-0.314	-14.726	7.066	0.001	0.051	0	-0.051
7.066	-46.782	6.96	6.972	-46.782	6.96	0.094	0	0	0.094
7.132	-36.773	6.95	6.972	-36.773	6.95	0.16	0	0	0.16
7.133	-26.767	6.941	6.972	-26.767	6.941	0.161	0	0	0.161
7.129	-16.76	6.931	6.972	-16.76	6.931	0.157	0	0	0.157
4.582	-17.724	6.928	4.447	-17.724	6.928	0.135	0	0	-0.135
4.564	-27.447	6.938	4.447	-27.447	6.938	0.117	0	0	-0.117
4.575	-37.17	6.948	4.447	-37.17	6.948	0.128	0	0	-0.128
4.564	-46.892	6.957	4.447	-46.892	6.957	0.117	0	0	-0.117
-3.969	-46.902	9.9	-3.97	-46.902	9.9	0.001	0	0	0.001
-3.89	-37.216	9.89	-3.97	-37.216	9.89	0.079	0	0	0.079
-3.863	-27.533	9.881	-3.97	-27.533	9.881	0.107	0	0	0.107
-3.86	-17.846	9.873	-3.97	-17.846	9.873	0.11	0	0	0.11
-8.02	-16.118	3.973	-8.178	-16.118	3.973	0.158	0	0	-0.158
-8.096	-26.318	3.983	-8.178	-26.318	3.983	0.082	0	0	-0.082
-8.11	-36.517	3.992	-8.178	-36.517	3.992	0.068	0	0	-0.068
-8.138	-46.718	4.001	-8.178	-46.718	4.001	0.04	0	0	-0.04
-5.912	-50.558	7.407	-5.912	-50.5	7.407	0	-0.058	0	0.058
5.837	-50.374	10.647	5.837	-50.5	10.647	0	0.126	0	-0.126
5.829	-46.545	12.55	5.829	-46.545	12.625	0	0	-0.075	-0.075
5.848	-37.5	12.507	5.848	-37.5	12.625	0	0	-0.118	-0.118
5.754	-28.457	12.424	5.754	-28.457	12.625	0	0	-0.201	-0.201
6.792	-17.488	12.747	6.972	-17.488	12.625	-0.18	0	0.122	0.217
-6.011	-16.933	12.573	-6.011	-16.933	12.625	0	0	-0.052	-0.052
-6.129	-27.337	12.643	-6.129	-27.337	12.625	0	0	0.018	0.018
-6.149	-36.155	12.605	-6.149	-36.155	12.625	0	0	-0.02	-0.02
-5.689	-47.907	12.584	-5.689	-47.907	12.625	0	0	-0.041	-0.041
63.162	-85.785	0.208	63.162	-85.785	0	0	0	0.208	0.208
51.732	-86.155	0.211	51.732	-86.155	0	0	0	0.211	0.211
30.986	-85.68	0.178	30.986	-85.68	0	0	0	0.178	0.178
27	-77.963	0.195	27	-77.963	0	0	0	0.195	0.195
40.186	-79.685	0.196	40.186	-79.685	0	0	0	0.196	0.196
56.621	-76.294	0.202	56.621	-76.294	0	0	0	0.202	0.202
61.269	-66.994	0.144	61.269	-66.994	0	0	0	0.144	0.144
47.278	-70.248	0.181	47.278	-70.248	0	0	0	0.181	0.181
37.758	-65.854	0.153	37.758	-65.854	0	0	0	0.153	0.153
24.107	-65.528	0.114	24.107	-65.528	0	0	0	0.114	0.114
20.144	-53.426	0.065	20.144	-53.426	0	0	0	0.065	0.065

15.375	-46.301	0.108	15.375	-46.301	0	0	0	0.108	0.108
23.784	-45.553	0.062	23.784	-45.553	0	0	0	0.062	0.062
15.022	-35.367	0.063	15.022	-35.367	0	0	0	0.063	0.063
15.884	-25.406	0.041	15.884	-25.406	0	0	0	0.041	0.041
25.797	-28.341	0.003	25.797	-28.341	0	0	0	0.003	0.003
33.782	-23.347	0.029	33.782	-23.347	0	0	0	0.029	0.029
61.873	-24.487	-0.008	61.873	-24.487	0	0	0	-0.008	-0.008
68.255	-35.006	0.017	68.255	-35.006	0	0	0	0.017	0.017
65.453	-54.978	0.048	65.453	-54.978	0	0	0	0.048	0.048
69.105	-6.556	-0.407	69.105	-6.556	0	0	0	-0.407	-0.407
66.273	18.441	-0.088	66.273	18.441	0	0	0	-0.088	-0.088
52.365	19.016	-0.061	52.365	19.016	0	0	0	-0.061	-0.061
38.488	18.764	-0.044	38.488	18.764	0	0	0	-0.044	-0.044
25.135	19.085	0.147	25.135	19.085	0	0	0	0.147	0.147
27.236	28.545	0.122	27.236	28.545	0	0	0	0.122	0.122
34.377	26.883	0.081	34.377	26.883	0	0	0	0.081	0.081
46.119	25.95	0.078	46.119	25.95	0	0	0	0.078	0.078
45.801	34.491	0.148	45.801	34.491	0	0	0	0.148	0.148
29.827	39.401	0.177	29.827	39.401	0	0	0	0.177	0.177
17.469	42.242	0.152	17.469	42.242	0	0	0	0.152	0.152
7.23	39.369	0.137	7.23	39.369	0	0	0	0.137	0.137
10.398	49.422	0.194	10.398	49.422	0	0	0	0.194	0.194
23.086	52.387	0.213	23.086	52.387	0	0	0	0.213	0.213
43.385	55.642	0.29	43.385	55.642	0	0	0	0.29	0.29
66.577	54.314	0.315	66.577	54.314	0	0	0	0.315	0.315
67.168	38.336	0.173	67.168	38.336	0	0	0	0.173	0.173
-12.054	40.839	0.072	-12.054	40.839	0	0	0	0.072	0.072
-22.627	17.544	0.117	-22.627	17.544	0	0	0	0.117	0.117
-23.932	30.734	0.037	-23.932	30.734	0	0	0	0.037	0.037
-31.11	26.047	0.04	-31.11	26.047	0	0	0	0.04	0.04
-42.839	26.706	0.046	-42.839	26.706	0	0	0	0.046	0.046
-50.333	30.558	0.048	-50.333	30.558	0	0	0	0.048	0.048
-40.29	46.111	0.099	-40.29	46.111	0	0	0	0.099	0.099
-47.414	54.667	0.033	-47.414	54.667	0	0	0	0.033	0.033
-75.426	53.878	0.041	-75.426	53.878	0	0	0	0.041	0.041
-75.639	37.595	0.113	-75.639	37.595	0	0	0	0.113	0.113
-74.42	19.438	0.13	-74.42	19.438	0	0	0	0.13	0.13
-56.943	25.342	0.073	-56.943	25.342	0	0	0	0.073	0.073
-65.981	12.034	0.115	-65.981	12.034	0	0	0	0.115	0.115
-68.491	-1.025	0.133	-68.491	-1.025	0	0	0	0.133	0.133
-76.844	-10.72	0.152	-76.844	-10.72	0	0	0	0.152	0.152

-76.702	-29.196	0.176	-76.702	-29.196	0	0	0	0.176	0.176
-62.437	-24.791	0.157	-62.437	-24.791	0	0	0	0.157	0.157
-49.751	-21.827	0.106	-49.751	-21.827	0	0	0	0.106	0.106
-35.42	-26.525	0.136	-35.42	-26.525	0	0	0	0.136	0.136
-22.668	-18.038	0.15	-22.668	-18.038	0	0	0	0.15	0.15
-27.678	-36.985	0.088	-27.678	-36.985	0	0	0	0.088	0.088
-13.544	-51.065	0.017	-13.544	-51.065	0	0	0	0.017	0.017
-5.042	-60.118	0.003	-5.042	-60.118	0	0	0	0.003	0.003
-6.277	-70.92	0.036	-6.277	-70.92	0	0	0	0.036	0.036
-7.619	-86.138	0.189	-7.619	-86.138	0	0	0	0.189	0.189
-27.045	-90.738	0.195	-27.045	-90.738	0	0	0	0.195	0.195
-40.739	-88.499	0.192	-40.739	-88.499	0	0	0	0.192	0.192
-53.497	-82.089	0.291	-53.497	-82.089	0	0	0	0.291	0.291
-62.704	-90.713	0.298	-62.704	-90.713	0	0	0	0.298	0.298
-77.031	-86.017	0.318	-77.031	-86.017	0	0	0	0.318	0.318
-75.379	-64.443	0.251	-75.379	-64.443	0	0	0	0.251	0.251
-71.776	-44.175	0.242	-71.776	-44.175	0	0	0	0.242	0.242
-65.619	-56.076	0.257	-65.619	-56.076	0	0	0	0.257	0.257
-61.99	-65.866	0.252	-61.99	-65.866	0	0	0	0.252	0.252
-50.276	-58.801	0.175	-50.276	-58.801	0	0	0	0.175	0.175
-50.026	-72.858	0.194	-50.026	-72.858	0	0	0	0.194	0.194
-13.897	-37.939	-16.794	-13.897	-37.939	-16.833	0	0	0.039	0.039
-14.298	-16.54	-16.75	-14.298	-16.54	-16.833	0	0	0.084	0.084
-13.485	16.135	-16.766	-13.485	16.135	-16.833	0	0	0.067	0.067
-13.321	29.343	-16.805	-13.321	29.343	-16.833	0	0	0.028	0.028
14.74	31.61	-16.743	14.74	31.61	-16.833	0	0	0.091	0.091
15.609	23.904	-16.776	15.609	23.904	-16.833	0	0	0.057	0.057
15.875	12.213	-16.749	15.875	12.213	-16.833	0	0	0.085	0.085
60.062	4.307	-16.374	60.062	4.307	-16.833	0	0	0.46	0.46
58.506	-9.964	-16.371	58.506	-9.964	-16.833	0	0	0.462	0.462
49.014	-15.259	-16.842	49.014	-15.259	-16.833	0	0	-0.009	-0.009
36.605	-9.667	-16.837	36.605	-9.667	-16.833	0	0	-0.004	-0.004
30.836	-17.692	-16.922	30.836	-17.692	-16.833	0	0	-0.088	-0.088
13.378	-15.178	-16.743	13.378	-15.178	-16.833	0	0	0.09	0.09
19.658	2.82	-4.13	19.658	2.82	-4.208	0	0	0.079	0.079
29.043	7.229	-4.157	29.043	7.229	-4.208	0	0	0.051	0.051
34.569	2.972	-4.163	34.569	2.972	-4.208	0	0	0.045	0.045
41.321	7.355	-4.235	41.321	7.355	-4.208	0	0	-0.026	-0.026
46.55	2.17	-4.07	46.55	2.17	-4.208	0	0	0.138	0.138
52.146	8.389	-4.156	52.146	8.389	-4.208	0	0	0.052	0.052
50.976	-4.171	-0.021	50.976	-4.03	0	0	-0.141	-0.021	-0.143

40.452	-3.954	0.018	40.452	-4.03	0	0	0.076	0.018	0.078
28.763	-3.795	-1.6	28.763	-4.03	-1.6	0	0.235	0	0.235
17.072	-2.007	-0.162	17.072	-2.007	0	0	0	-0.162	-0.162
18.692	-9.333	1.667	18.692	-9.333	1.683	0	0	-0.017	-0.017
24.851	-6.496	1.613	24.851	-6.496	1.683	0	0	-0.07	-0.07
26.945	-14.806	1.175	27.115	-14.806	1.175	-0.17	0	0	0.17
18.93	-11.932	-3.905	18.93	-12.447	-3.905	0	0.515	0	-0.515
24.845	-15.878	0.484	24.59	-15.878	0.484	0.255	0	0	0.255
33.137	-3.541	-3.969	33.137	-4.03	-3.969	0	0.489	0	-0.489
40.159	-3.487	-3.211	40.159	-4.03	-3.211	0	0.543	0	-0.543
52.78	-3.494	-4.477	52.78	-4.03	-4.477	0	0.536	0	-0.536
54.935	0.226	-8.754	55.267	0.12	-8.754	-0.332	0.106	0	-0.349
56.268	7.9	-9.508	56.527	7.9	-9.508	-0.259	0	0	-0.259
59.608	12.476	-0.64	59.608	12.449	-0.583	0	0.027	-0.057	-0.063
49.392	13.342	-1.453	49.392	13.264	-1.319	0	0.077	-0.134	-0.155
39.554	12.617	-1.35	39.554	12.483	-1.216	0	0.134	-0.134	-0.189

*Appendix G      Magnesium Castings -  
Histograms (3D-Tol  
Data)*

Histogram for 3DP Magnesium Casting

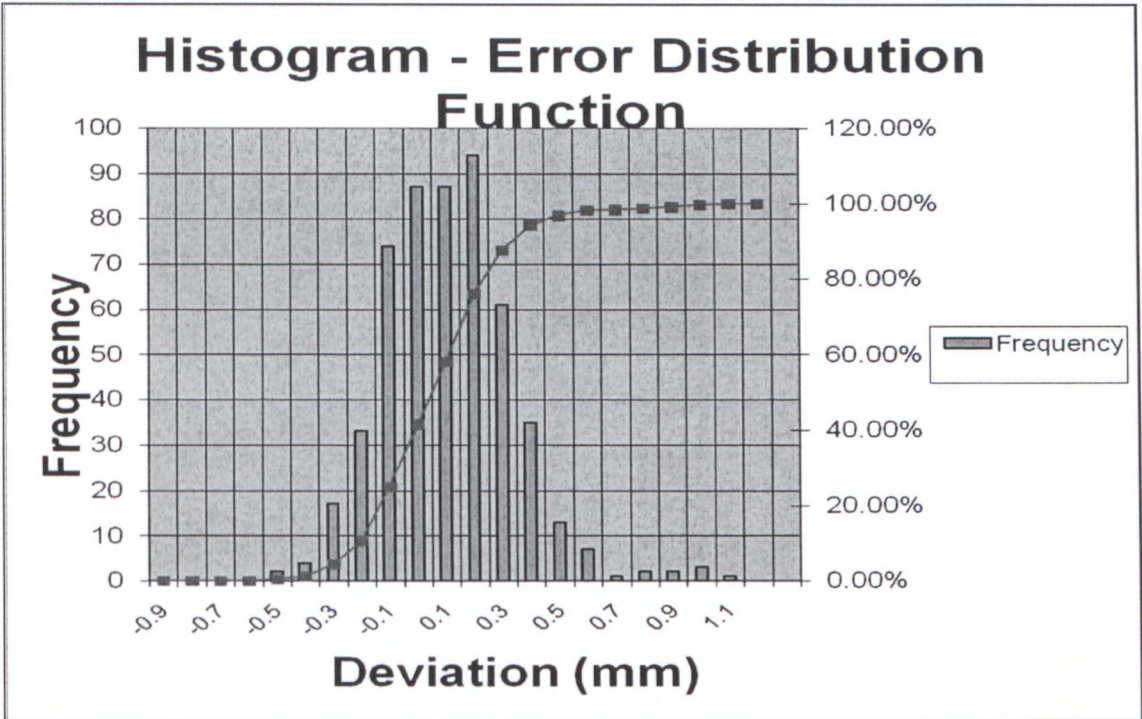

Histogram for SLS Magnesium Casting

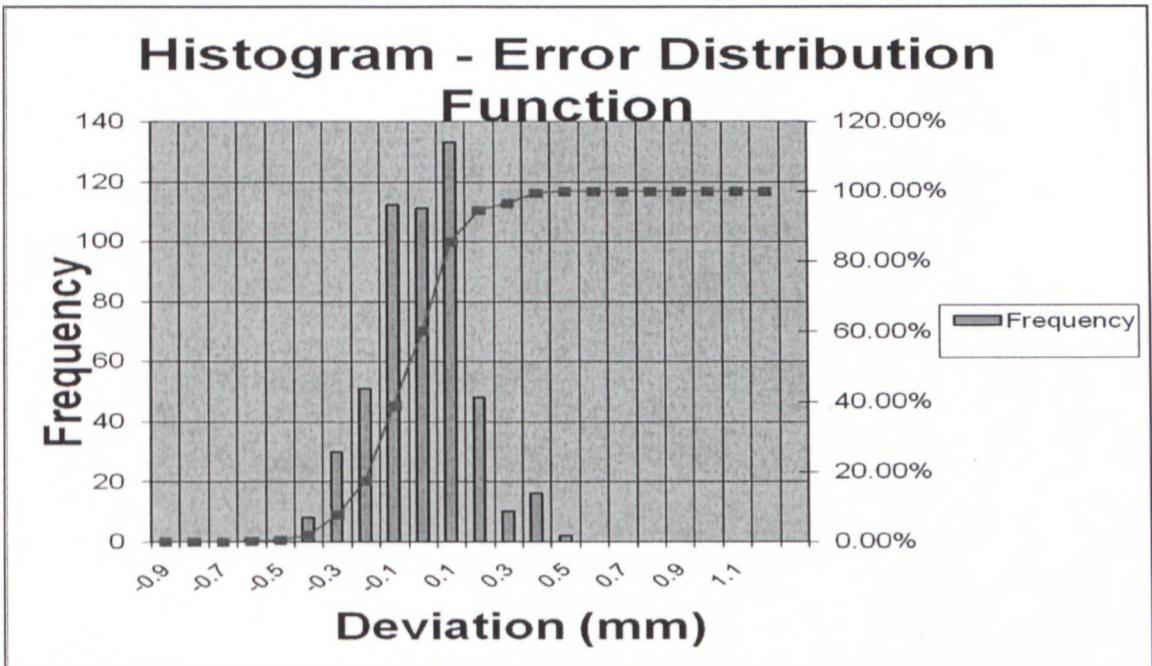

Histogram for ThermoJet Magnesium Casting

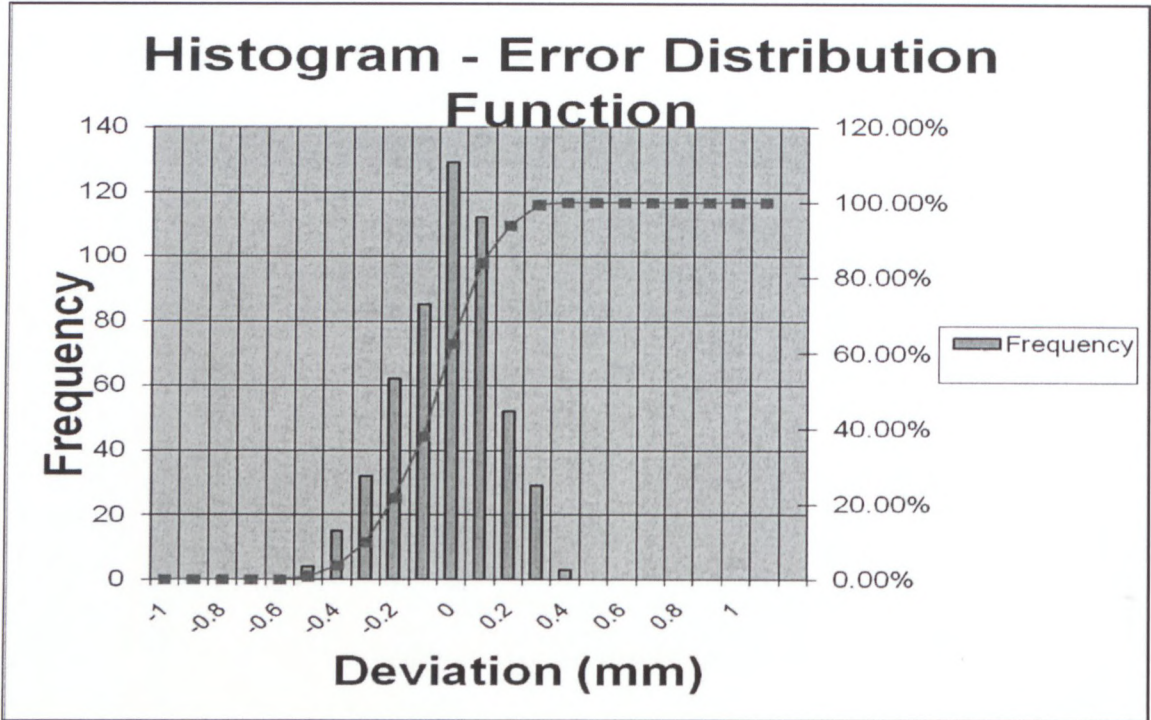

Histogram for Polyamide Magnesium Casting

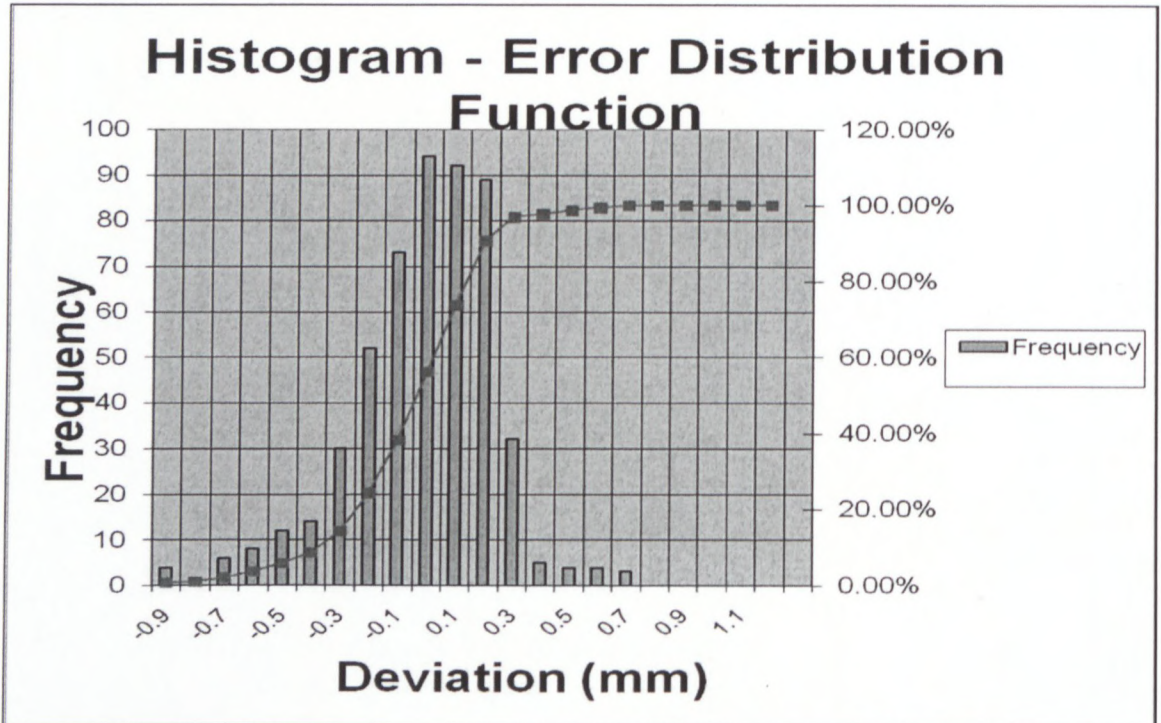

*Appendix H      Titanium Castings -  
Features CMM Data*

A basic tolerance of  $\pm 0.5$  mm is used for all feature measurements on all castings.

## Feature Tolerances – 3DP Titanium Casting

Feature Tolerances - 3DP Casting Pattern 7										
Tolerance No.	Feature	Tol.ElemName	Compared to	Type of Tolerance	Spec.	Lower Tol.	Upper Tol.	Actual	Tol. Deviation	Result
A1	Square Base	Line	Point	Distance	58.92	-0.500	0.500	60.772	1.852	High
A2	Pattern	Line	Point	Distance	71.54	-0.500	0.500	71.417	-0.123	Good
A3	Pattern	Line	Point	Distance	2.1	-0.500	0.500	1.980	-0.120	Good
A4	Rectangular Protrosion	Line	Point	Distance	25.25	-0.500	0.500	25.232	-0.018	Good
A5	Rectangular Protrosion	Line	Point	Distance	8.42	-0.500	0.500	8.494	0.074	Good
A6	Rectangular Protrosion	Line	Point	Distance	8.42	-0.500	0.500	7.731	-0.689	Low
A7	Pattern	Line	Point	Distance	8.42	-0.500	0.500	8.005	-0.415	Good
A8	Wedge X	Line	Point	Distance	12.63	-0.500	0.500	12.704	0.074	Good
A9	Cube 1	Line	Point	Distance	8.42	-0.500	0.500	7.957	-0.463	Good
A10	Cube 1	Line	Point	Distance	8.42	-0.500	0.500	8.532	0.112	Good
A11	Cube 1	Line	Point	Distance	8.42	-0.500	0.500	7.986	-0.434	Good
A12	Rectangular Hole	Line	Point	Distance	25.2	-0.500	0.500	25.419	0.219	Good
A13	Rectangular Hole	Line	Point	Distance	8.42	-0.500	0.500	8.784	0.364	Good
A14	Cube 2	Line	Point	Distance	8.42	-0.500	0.500	8.530	0.110	Good
A15	Cube 2	Line	Point	Distance	8.42	-0.500	0.500	7.591	-0.829	Low
A16	Pattern	Line	Point	Distance	2.53	-0.500	0.500	2.046	-0.484	Good
B1	Square Base	Line	Point	Distance	151.5	-0.500	0.500	151.425	-0.075	Good
B2	Cube 1	Line	Point	Distance	8.42	-0.500	0.500	8.266	-0.154	Good
C1	Rectangular Protrusion	Line	Point	Distance	8.42	-0.500	0.500	8.553	0.133	Good
C2	Pattern	Line	Point	Distance	1.68	-0.500	0.500	1.453	-0.227	Good
C3	Rectangular Protrusion	Line	Point	Distance	25.25	-0.500	0.500	24.467	-0.783	Low
C4	Square Base	Line	Point	Distance	151.5	-0.500	0.500	151.425	-0.075	Good

C5	Wedge X	Line	Point	Distance	25.25	-0.500	0.500	24.395	-0.855	Low
C6	Cube 1	Line	Point	Distance	8.42	-0.500	0.500	7.932	-0.488	Good
CC3	Cube 1	Line	Point	Distance	8.42	-0.500	0.500	7.986	-0.434	Good
CC4	Cube 1	Line	Point	Distance	8.42	-0.500	0.500	8.532	0.112	Good
CC5	Cylinder Depth	Line	Point	Distance	16.83	-0.500	0.500	15.762	-1.068	Low
D1	Square Base Depth	Line	Point	Distance	29.46	-0.500	0.500	29.244	-0.216	Good
D2	Cube 3	Line	Point	Distance	4.21	-0.500	0.500	3.988	-0.222	Good
D3	Cube 3	Line	Point	Distance	8.42	-0.500	0.500	8.493	0.073	Good
D4	Cube 2	Line	Point	Distance	8.42	-0.500	0.500	8.363	-0.057	Good
E1	Square Base	Line	Point	Distance	151.5	-0.500	0.500	151.725	0.225	Good
E2	Wedge Y	Line	Point	Distance	25.25	-0.500	0.500	25.146	-0.104	Good
E3	Wedge Y	Line	Point	Distance	12.63	-0.500	0.500	12.432	-0.198	Good
E4	Wedge Y	Line	Point	Distance	6.73	-0.500	0.500	6.592	-0.138	Good
E5	Cube 4	Line	Point	Distance	8.42	-0.500	0.500	7.857	-0.563	Low
E6	Rectangular Hole	Line	Point	Distance	8.42	-0.500	0.500	9.025	0.605	High
E7	Rectangular Hole	Line	Point	Distance	25.25	-0.500	0.500	25.629	0.379	Good
E8	Cube 3	Line	Point	Distance	8.42	-0.500	0.500	7.904	-0.516	Low
E9	Cube 3	Line	Point	Distance	8.42	-0.500	0.500	6.942	-1.478	Low
E10	Cylinder Inner Diameter	Line	Point	Distance	21.04	-0.500	0.500	21.181	0.141	Good
E11	Cylinder Outer Diameter	Line	Point	Distance	29.46	-0.500	0.500	29.115	-0.345	Good
E12	Square Base	Line	Point	Distance	151.5	-0.500	0.500	151.484	-0.016	Good
EE1	Triangular Hole	Line	Point	Distance	5.89	-0.500	0.500	5.657	-0.233	Good
EE2	Thin Walls	Line	Point	Distance	4.21	-0.500	0.500	3.940	-0.270	Good
EE3	Thin Walls	Line	Point	Distance	2.53	-0.500	0.500	2.313	-0.217	Good
AA2	Wedge X-direction	Line	Line	Angularity	75	-0.500	0.500	76.388	1.388	High
AA3	Wedge X-direction	Line	Line	Angularity	75	-0.500	0.500	74.994	-0.006	Good
BB2	Wedge Y-direction	Line	Line	Angularity	60	-0.500	0.500	61.132	1.132	High
BB3	Wedge Y-direction	Line	Line	Angularity	75	-0.500	0.500	76.336	1.336	High
CC1	Pyramid	Line	Line	Angularity	106.7	-0.500	0.500	107.245	0.545	High

CC2	Pyramid	Line	Line	Angularity	106.7	-0.500	0.500	106.352	-0.348	Good
DD1	Pyramid	Line	Line	Angularity	111.8	-0.500	0.500	111.970	0.170	Good
DD2	Pyramid	Line	Line	Angularity	111.8	-0.500	0.500	112.908	1.108	High
T1	Triangular Hole	Line	Line	Perpendicularity		-0.500	0.500	0.185	0.185	Good
T2	Cylinder Hole/ Hollow Cylinder	Outer Circle	Inner Circle	Circularity		-0.500	0.500	0.279	0.279	Good
T3	Cylinder Hole/ Hollow Cylinder	Outer Circle	Inner Circle	Concentricity		-0.500	0.500	0.128	0.128	Good
T4	Cylinder Hole/ Hollow Cylinder	Outer Circle	Inner Circle	Circularity		-0.500	0.500	0.232	0.232	Good
T5	Square Base	Plane	Bottom Side	Flatness		-0.500	0.500	0.564	0.564	High
T6	Square Base	Left_Side	Bottom Side	Perpendicularity		-0.500	0.500	0.373	0.373	Good
T7	Square Base	Top_Side	Right Side	Perpendicularity		-0.500	0.500	0.137	0.137	Good
T8	Square Base	Left_Side	Right Side	Parallelism		-0.500	0.500	0.437	0.437	Good
T9	Square Base	Top_Side	Bottom Side	Parallelism		-0.500	0.500	0.073	0.073	Good
T10	Thin Walls	Line	Line	Parallelism		-0.500	0.500	2.159	2.159	High
T11	Thin Walls	Line	Line	Parallelism		-0.500	0.500	0.040	0.040	Good
T12	Thin Walls	Line	Line	Thickness		-0.500	0.500	0.110	0.110	Good
T13	Thin Walls	Line	Line	Thickness		-0.500	0.500	0.129	0.129	Good
T14	Cube's 2,3,1	Cube231		Straightness		-0.500	0.500	0.013	0.013	Good
T15	Cube's 1,4, RecProtr	Cube14Rec		Straightness		-0.500	0.500	0.168	0.168	Good
T16	Rectangular Protrusion Outer	RecP2	RecP1	Perpendicularity		-0.500	0.500	1.130	1.130	High
T17	Rectangular Protrusion Inner	RecP4	RecP3	Perpendicularity		-0.500	0.500	1.157	1.157	High
T18	Rectangular Hole Outer	Rech4	Rech3	Perpendicularity		-0.500	0.500	1.025	1.025	High
T19	Rectangular Hole Inner	Rech1	Rech2	Perpendicularity		-0.500	0.500	1.114	1.114	High
T23	Cone	Actual Cone Axis	Cone	Symmetry tol. axis element		-0.500	0.500	0.020	0.020	Good
T24	Cone	Cone Bottom Circle	Cone	Circular runout		-0.500	0.500	0.380	0.380	Good
T26	Cone	Cone Bottom Circle	Theoretical	Circular runout		-0.500	0.500	1.259	1.259	High

T29	Cone	plane_2	Cone Axis	Axial runout		-0.500	0.500	1.408	1.408	High
T31	Cone	Cone	plane_2	Symmetry tol. axis element		-0.500	0.500	0.135	0.135	Good
T32	Cone	Cone Bottom Circle	Cone	Symmetry tol. point element		-0.500	0.500	0.027	0.027	Good
T33	Cone	Cone	plane_2	Angularity		-0.500	0.500	0.024	0.024	Good
T34	Cone	Cone	Theoretical Cone Axis	Coaxiality		-0.500	0.500	1.195	1.195	High
T36	Cone	Cone	Actual Cone Axis	Coaxiality		-0.500	0.500	0.254	0.254	Good
T37	Cone	Cone_Bottom_Circle	Actual Cone Axis	Circular runout		-0.500	0.500	0.283	0.283	Good
T38	Sphere	Sphere Bottom Circle	Sphere Axis	Circular runout		-0.500	0.500	0.744	0.744	High
T39	Sphere	Sphere Bottom Circle	Actual Sphere Axis	Circular runout		-0.500	0.500	0.275	0.275	Good
T41	Sphere	plane_2	Actual Sphere Axis	Axial runout		-0.500	0.500	3.664	3.664	High
T42	Sphere	plane_2	Sphere	Symmetry tol. plane element		-0.500	0.500	2.764	2.764	High
T43	Sphere	Theoretical Sphere Axis	Sphere	Symmetry tol. axis element		-0.500	0.500	0.019	0.019	Good
T47	Sphere	Sphere Bottom Circle	Sphere	Symmetry tol. point element		-0.500	0.500	0.061	0.061	Good
T51	Sphere	Actual Sphere Axis	Theoretical Sphere Axis	Coaxiality		-0.500	0.500	0.696	0.696	High
T52	Sphere	Sphere	Sphere Bottom Circle	Concentricity		-0.500	0.500	0.141	0.141	Good
T54	Dome	Dome Bottom Circle	Actual Dome axis	Circular runout		-0.500	0.500	0.303	0.303	Good

T56	Dome	Dome Upper Circle	Actual Dome axis	Circular runout		-0.500	0.500	0.243	0.243	Good
T58	Dome	plane_2	Actual Dome axis	Axial runout		-0.500	0.500	1.757	1.757	High
T65	Dome	Dome Bottom Circle	Dome Upper Circle	Symmetry tol. point element		-0.500	0.500	0.192	0.192	Good
T67	Dome	plane_2	Actual Dome axis	Perpendicularity		-0.500	0.500	0.351	0.351	Good
T69	Dome	Dome Upper Circle	Dome Bottom Circle	Concentricity		-0.500	0.500	0.229	0.229	Good
T70	Sinkhole	Sinkhole Upper Circle	Theoretical Sinkhole axis	Circular runout		-0.500	0.500	0.673	0.673	Good
T71	Sinkhole	Sinkhole Upper Circle	Actual Sinkhole Axis	Circular runout		-0.500	0.500	0.138	0.138	High
T72	Sinkhole	Sinkhole Bottom Circle	Theoretical Sinkhole axis	Circular runout		-0.500	0.500	0.861	0.861	Good
T73	Sinkhole	Sinkhole Bottom Circle	Actual Sinkhole Axis	Circular runout		-0.500	0.500	0.255	0.255	High
T79	Sinkhole	Theoretical Sinkhole Axis	plane_2	Symmetry tol. axis element		-0.500	0.500	0.118	0.118	Good
T82	Sinkhole	Sinkhole Bottom Circle	Sinkhole Bottom Circle	Symmetry tol. point element		-0.500	0.500	0.142	0.142	Good
T84	Sinkhole	plane_2	Actual Sinkhole Axis	Perpendicularity		-0.500	0.500	0.952	0.952	Good
T85	Sinkhole	Actual Sinkhole Axis	Theoretical Sinkhole axis	Coaxiality		-0.500	0.500	0.488	0.488	High
										Good

T86	Sinkhole	Sinkhole Bottom Circle	Sinkhole Lower Circle	Concentricity	-0.500	0.500	0.262	0.262	Good
-----	----------	------------------------	-----------------------	---------------	--------	-------	-------	-------	------

### Feature Tolerances – SLS Titanium Casting

Feature Tolerances - SLS Casting Pattern 5										
Tolerance No.	Feature	Tol.ElemName	Compared to	Type of Tolerance	Spec.	Lower Tol.	Upper Tol.	Actual	Tol. Deviation	Result
A1	Square Base	Line	Point	Distance	58.92	-0.500	0.500	60.842	1.922	High
A2	Pattern	Line	Point	Distance	71.54	-0.500	0.500	71.862	0.322	Good
A3	Pattern	Line	Point	Distance	2.1	-0.500	0.500	2.153	0.053	Good
A4	Rectangular Protrosion	Line	Point	Distance	25.25	-0.500	0.500	25.255	0.005	Good
A5	Rectangular Protrosion	Line	Point	Distance	8.42	-0.500	0.500	8.379	-0.041	Good
A6	Rectangular Protrosion	Line	Point	Distance	8.42	-0.500	0.500	8.290	-0.130	Good
A7	Pattern	Line	Point	Distance	8.42	-0.500	0.500	8.446	0.026	Good
A8	Wedge X	Line	Point	Distance	12.63	-0.500	0.500	12.665	0.035	Good
A9	Cube 1	Line	Point	Distance	8.42	-0.500	0.500	8.402	-0.018	Good
A10	Cube 1	Line	Point	Distance	8.42	-0.500	0.500	8.349	-0.071	Good
A11	Cube 1	Line	Point	Distance	8.42	-0.500	0.500	8.473	0.053	Good
A12	Rectangular Hole	Line	Point	Distance	25.2	-0.500	0.500	25.225	0.025	Good
A13	Rectangular Hole	Line	Point	Distance	8.42	-0.500	0.500	8.412	-0.008	Good
A14	Cube 2	Line	Point	Distance	8.42	-0.500	0.500	8.185	-0.235	Good
A15	Cube 2	Line	Point	Distance	8.42	-0.500	0.500	8.473	0.053	Good
A16	Pattern	Line	Point	Distance	2.53	-0.500	0.500	2.540	0.010	Good
B1	Square Base	Line	Point	Distance	151.5	-0.500	0.500	151.993	0.493	Good
B2	Cube 1	Line	Point	Distance	8.42	-0.500	0.500	8.244	-0.176	Good

C1	Rectangular Protrusion	Line	Point	Distance	8.42	-0.500	0.500	8.147	-0.273	Good
C2	Pattern	Line	Point	Distance	1.68	-0.500	0.500	1.586	-0.094	Good
C3	Rectangular Protrusion	Line	Point	Distance	25.25	-0.500	0.500	25.386	0.136	Good
C4	Square Base	Line	Point	Distance	151.5	-0.500	0.500	151.993	0.493	Good
C5	Wedge X	Line	Point	Distance	25.25	-0.500	0.500	25.421	0.171	Good
C6	Cube 1	Line	Point	Distance	8.42	-0.500	0.500	8.558	0.138	Good
CC3	Cube 1	Line	Point	Distance	8.42	-0.500	0.500	8.473	0.053	Good
CC4	Cube 1	Line	Point	Distance	8.42	-0.500	0.500	8.349	-0.071	Good
CC5	Cylinder Depth	Line	Point	Distance	16.83	-0.500	0.500	17.000	0.170	Good
D1	Square Base Depth	Line	Point	Distance	29.46	-0.500	0.500	31.609	2.149	High
D2	Cube 3	Line	Point	Distance	4.21	-0.500	0.500	4.018	-0.192	Good
D3	Cube 3	Line	Point	Distance	8.42	-0.500	0.500	8.452	0.032	Good
D4	Cube 2	Line	Point	Distance	8.42	-0.500	0.500	8.464	0.044	Good
E1	Square Base	Line	Point	Distance	151.5	-0.500	0.500	151.652	0.152	Good
E2	Wedge Y	Line	Point	Distance	25.25	-0.500	0.500	25.193	-0.057	Good
E3	Wedge Y	Line	Point	Distance	12.63	-0.500	0.500	12.473	-0.157	Good
E4	Wedge Y	Line	Point	Distance	6.73	-0.500	0.500	6.845	0.115	Good
E5	Cube 4	Line	Point	Distance	8.42	-0.500	0.500	8.438	0.018	Good
E6	Rectangular Hole	Line	Point	Distance	8.42	-0.500	0.500	8.403	-0.017	Good
E7	Rectangular Hole	Line	Point	Distance	25.25	-0.500	0.500	25.379	0.129	Good
E8	Cube 3	Line	Point	Distance	8.42	-0.500	0.500	8.464	0.044	Good
E9	Cube 3	Line	Point	Distance	8.42	-0.500	0.500	8.592	0.172	Good
E10	Cylinder Inner Diameter	Line	Point	Distance	21.04	-0.500	0.500	20.908	-0.132	Good
E11	Cylinder Outer Diameter	Line	Point	Distance	29.46	-0.500	0.500	29.463	0.003	Good
E12	Square Base	Line	Point	Distance	151.5	-0.500	0.500	151.762	0.262	Good
EE1	Triangular Hole	Line	Point	Distance	5.89	-0.500	0.500	6.061	0.171	Good
EE2	Thin Walls	Line	Point	Distance	4.21	-0.500	0.500	4.221	0.011	Good
EE3	Thin Walls	Line	Point	Distance	2.53	-0.500	0.500	2.675	0.145	Good
AA2	Wedge X-direction	Line	Line	Angularity	75	-0.500	0.500	74.597	-0.403	Good

AA3	Wedge X-direction	Line	Line	Line	Angularity	75	-0.500	0.500	75.527	0.527	High
BB2	Wedge Y-direction	Line	Line	Line	Angularity	60	-0.500	0.500	59.824	-0.176	Good
BB3	Wedge Y-direction	Line	Line	Line	Angularity	75	-0.500	0.500	75.066	0.066	Good
CC1	Pyramid	Line	Line	Line	Angularity	106.7	-0.500	0.500	106.248	-0.452	Good
CC2	Pyramid	Line	Line	Line	Angularity	106.7	-0.500	0.500	106.464	-0.236	Good
DD1	Pyramid	Line	Line	Line	Angularity	111.8	-0.500	0.500	112.328	0.528	High
DD2	Pyramid	Line	Line	Line	Angularity	111.8	-0.500	0.500	110.446	-1.354	Low
T1	Triangular Hole	Line	Line	Line	Perpendicularity		-0.500	0.500	0.028	0.028	Good
T2	Cylinder Hole/ Hollow Cylinder	Outer Circle	Outer Circle	Inner Circle	Circularity		-0.500	0.500	0.025	0.025	Good
T3	Cylinder Hole/ Hollow Cylinder	Outer Circle	Outer Circle	Inner Circle	Concentricity		-0.500	0.500	0.075	0.075	Good
T4	Cylinder Hole/ Hollow Cylinder	Outer Circle	Outer Circle	Inner Circle	Circularity		-0.500	0.500	0.044	0.044	Good
T5	Square Base	Plane	Plane	Bottom Side	Flatness		-0.500	0.500	0.434	0.434	Good
T6	Square Base	Left_Side	Left_Side	Bottom Side	Perpendicularity		-0.500	0.500	0.031	0.031	Good
T7	Square Base	Top_Side	Top_Side	Right Side	Perpendicularity		-0.500	0.500	0.019	0.019	Good
T8	Square Base	Left_Side	Left_Side	Right Side	Parallelism		-0.500	0.500	0.059	0.059	Good
T9	Square Base	Top_Side	Top_Side	Bottom Side	Parallelism		-0.500	0.500	0.046	0.046	Good
T10	Thin Walls	Line	Line	Line	Parallelism		-0.500	0.500	0.188	0.188	Good
T11	Thin Walls	Line	Line	Line	Parallelism		-0.500	0.500	0.055	0.055	Good
T12	Thin Walls	Line	Line	Line	Thickness		-0.500	0.500	0.210	0.210	Good
T13	Thin Walls	Line	Line	Line	Thickness		-0.500	0.500	0.221	0.221	Good
T14	Cube's 2,3,1	Cube231	Cube231	Cube231	Straightness		-0.500	0.500	0.018	0.018	Good
T15	Cube's 1,4, RecProtr	Cube14Rec	Cube14Rec	Cube14Rec	Straightness		-0.500	0.500	0.010	0.010	Good
T16	Rectangular Protrusion Outer	RecP2	RecP2	RecP1	Perpendicularity		-0.500	0.500	0.096	0.096	Good
T17	Rectangular Protrusion Inner	RecP4	RecP4	RecP3	Perpendicularity		-0.500	0.500	0.411	0.411	Good
T18	Rectangular Hole Outer	RecH4	RecH4	RecH3	Perpendicularity		-0.500	0.500	0.142	0.142	Good
T19	Rectangular Hole Inner	RecH1	RecH1	RecH2	Perpendicularity		-0.500	0.500	0.278	0.278	Good

T23	Cone	Actual Cone Axis	Cone	Symmetry tol. axis element	-0.500	0.500	0.179	0.179	Good
T24	Cone	Cone Bottom Circle	Cone	Circular runout	-0.500	0.500	0.146	0.146	Good
T26	Cone	Cone Bottom Circle	Theoretical Cone Axis	Circular runout	-0.500	0.500	0.566	0.566	High
T29	Cone	plane_2	Cone	Axial runout	-0.500	0.500	3.217	3.217	High
T31	Cone	Cone	plane_2	Symmetry tol. axis element	-0.500	0.500	0.381	0.381	Good
T32	Cone	Cone Bottom Circle	Cone	Symmetry tol. point element	-0.500	0.500	0.037	0.037	Good
T33	Cone	Cone	plane_2	Angularity	-0.500	0.500	0.022	0.022	Good
T34	Cone	Cone	Theoretical Cone Axis	Coaxiality	-0.500	0.500	0.506	0.506	High
T36	Cone	Cone	Actual Cone Axis	Coaxiality	-0.500	0.500	0.187	0.187	Good
T37	Cone	Cone_Bottom_Circle	Actual Cone Axis	Circular runout	-0.500	0.500	0.053	0.053	Good
T38	Sphere	Sphere Bottom Circle	Sphere Bottom Axis	Circular runout	-0.500	0.500	0.263	0.263	Good
T39	Sphere	Sphere Bottom Circle	Actual Sphere Axis	Circular runout	-0.500	0.500	0.064	0.064	Good
T41	Sphere	plane_2	Actual Sphere Axis	Axial runout	-0.500	0.500	1.577	1.577	Good
T42	Sphere	plane_2	Sphere	Symmetry tol. plane element	-0.500	0.500	4.026	4.026	High
T43	Sphere	Theoretical Sphere Axis	Sphere	Symmetry tol. axis element	-0.500	0.500	0.153	0.153	High
T47	Sphere	Sphere Bottom Circle	Sphere	Symmetry tol. axis element	-0.500	0.500	0.059	0.059	Good
T51	Sphere	Actual Sphere Axis	Theoretical Sphere Axis	Coaxiality	-0.500	0.500	0.268	0.268	Good
T52	Sphere	Sphere	Sphere Bottom	Concentricity	-0.500	0.500	0.071	0.071	Good

T54	Dome	Dome Bottom Circle	Circle Actual Dome axis	Circular runout	-0.500	0.500	0.070	0.070	Good
T56	Dome	Dome Upper Circle	Circle Actual Dome axis	Circular runout	-0.500	0.500	0.061	0.061	Good
T58	Dome	plane_2	Circle Actual Dome axis	Axial runout	-0.500	0.500	2.108	2.108	High
T65	Dome	Dome Bottom Circle	Circle Dome Upper Circle	Symmetry tol. point element	-0.500	0.500	0.095	0.095	Good
T67	Dome	plane_2	Circle Actual Dome axis	Perpendicularity	-0.500	0.500	0.422	0.422	Good
T69	Dome	Dome Upper Circle	Circle Dome Bottom Circle	Concentricity	-0.500	0.500	0.200	0.200	Good
T70	Sinkhole	Sinkhole Upper Circle	Circle Theoretical Sinkhole axis	Circular runout	-0.500	0.500	0.088	0.088	Good
T71	Sinkhole	Sinkhole Upper Circle	Circle Actual Sinkhole Axis	Circular runout	-0.500	0.500	0.074	0.074	Good
T72	Sinkhole	Sinkhole Bottom Circle	Circle Theoretical Sinkhole axis	Circular runout	-0.500	0.500	0.274	0.274	Good
T73	Sinkhole	Sinkhole Bottom Circle	Circle Actual Sinkhole Axis	Circular runout	-0.500	0.500	0.036	0.036	Good
T79	Sinkhole	Theoretical Sinkhole Axis	plane_2	Symmetry tol. axis element	-0.500	0.500	0.339	0.339	Good
T82	Sinkhole	Sinkhole Bottom Circle	Circle Sinkhole Bottom Circle	Symmetry tol. point element	-0.500	0.500	0.126	0.126	Good
T84	Sinkhole	plane_2	Circle Actual Sinkhole Axis	Perpendicularity	-0.500	0.500	0.788	0.788	High

T85	Sinkhole	Actual Sinkhole Axis	Theoretical Sinkhole axis	Coaxiality	-0.500	0.500	0.061	0.061	Good
		Sinkhole Bottom Circle	Sinkhole Lower Circle	Concentricity	-0.500	0.500	0.224	0.224	
T86	Sinkhole								Good

### Feature Tolerances – ThermetJet Titanium Casting

Feature Tolerances - Alumide Casting Pattern 3										
Tolerance No.	Feature	Tol.ElemName	Compared to	Type of Toleranc <sup>e</sup>	Spec.	Lower Tol.	Upper Tol.	Actual	Tol. Deviation	Result
A1	Square Base	Line	Point	Distance	58.92	-0.500	0.500	60.929	2.009	High
A2	Pattern	Line	Point	Distance	71.54	-0.500	0.500	71.180	-0.360	Good
A3	Pattern	Line	Point	Distance	2.1	-0.500	0.500	1.090	-1.010	Low
A4	Rectangular Protrosion	Line	Point	Distance	25.25	-0.500	0.500	24.968	-0.282	Good
A5	Rectangular Protrosion	Line	Point	Distance	8.42	-0.500	0.500	7.955	-0.465	Good
A6	Rectangular Protrosion	Line	Point	Distance	8.42	-0.500	0.500	8.067	-0.353	Good
A7	Pattern	Line	Point	Distance	8.42	-0.500	0.500	7.958	-0.462	Good
A8	Wedge X	Line	Point	Distance	12.63	-0.500	0.500	12.691	0.061	Good
A9	Cube 1	Line	Point	Distance	8.42	-0.500	0.500	7.854	-0.566	Low
A10	Cube 1	Line	Point	Distance	8.42	-0.500	0.500	8.002	-0.418	Good
A11	Cube 1	Line	Point	Distance	8.42	-0.500	0.500	7.927	-0.493	Good
A12	Rectangular Hole	Line	Point	Distance	25.2	-0.500	0.500	25.347	0.147	Good
A13	Rectangular Hole	Line	Point	Distance	8.42	-0.500	0.500	8.399	-0.021	Good
A14	Cube 2	Line	Point	Distance	8.42	-0.500	0.500	7.759	-0.661	Low
A15	Cube 2	Line	Point	Distance	8.42	-0.500	0.500	7.839	-0.581	Low
A16	Pattern	Line	Point	Distance	2.53	-0.500	0.500	1.548	-0.982	Low

B1	Square Base	Line	Point	Distance	151.5	-0.500	0.500	150.852	-0.648	Low
B2	Cube 1	Line	Point	Distance	8.42	-0.500	0.500	8.420	0.000	Good
C1	Rectangular Protrusion	Line	Point	Distance	8.42	-0.500	0.500	8.531	0.111	Good
C2	Pattern	Line	Point	Distance	1.68	-0.500	0.500	2.768	1.088	High
C3	Rectangular Protrusion	Line	Point	Distance	25.25	-0.500	0.500	24.863	-0.387	Good
C4	Square Base	Line	Point	Distance	151.5	-0.500	0.500	150.852	-0.648	Low
C5	Wedge X	Line	Point	Distance	25.25	-0.500	0.500	24.435	-0.815	Low
C6	Cube 1	Line	Point	Distance	8.42	-0.500	0.500	7.844	-0.576	Low
CC3	Cube 1	Line	Point	Distance	8.42	-0.500	0.500	7.927	-0.493	Good
CC4	Cube 1	Line	Point	Distance	8.42	-0.500	0.500	8.002	-0.418	Good
CC5	Cylinder Depth	Line	Point	Distance	16.83	-0.500	0.500	16.411	-0.419	Good
D1	Square Base Depth	Line	Point	Distance	29.46	-0.500	0.500	35.222	5.762	High
D2	Cube 3	Line	Point	Distance	4.21	-0.500	0.500	4.180	-0.030	Good
D3	Cube 3	Line	Point	Distance	8.42	-0.500	0.500	8.146	-0.274	Good
D4	Cube 2	Line	Point	Distance	8.42	-0.500	0.500	7.763	-0.657	Low
E1	Square Base	Line	Point	Distance	151.5	-0.500	0.500	151.252	-0.248	Good
E2	Wedge Y	Line	Point	Distance	25.25	-0.500	0.500	24.649	-0.601	Low
E3	Wedge Y	Line	Point	Distance	12.63	-0.500	0.500	12.520	-0.110	Good
E4	Wedge Y	Line	Point	Distance	6.73	-0.500	0.500	6.143	-0.587	Low
E5	Cube 4	Line	Point	Distance	8.42	-0.500	0.500	8.072	-0.348	Good
E6	Rectangular Hole	Line	Point	Distance	8.42	-0.500	0.500	8.636	0.216	Good
E7	Rectangular Hole	Line	Point	Distance	25.25	-0.500	0.500	25.580	0.330	Good
E8	Cube 3	Line	Point	Distance	8.42	-0.500	0.500	8.123	-0.297	Good
E9	Cube 3	Line	Point	Distance	8.42	-0.500	0.500	7.573	-0.847	Low
E10	Cylinder Inner Diameter	Line	Point	Distance	21.04	-0.500	0.500	21.260	0.220	Good
E11	Cylinder Outer Diameter	Line	Point	Distance	29.46	-0.500	0.500	29.480	0.020	Good
E12	Square Base	Line	Point	Distance	151.5	-0.500	0.500	150.805	-0.695	Low
EE1	Triangular Hole	Line	Point	Distance	5.89	-0.500	0.500	5.766	-0.124	Good
EE2	Thin Walls	Line	Point	Distance	4.21	-0.500	0.500	4.126	-0.084	Good

	Thin Walls	Line	Point	Distance	2.53	-0.500	0.500	2.522	-0.008	Good
EE3	Thin Walls	Line	Point	Distance	2.53	-0.500	0.500	2.522	-0.008	Good
AA2	Wedge X-direction	Line	Line	Angularity	75	-0.500	0.500	74.282	-0.718	Low
AA3	Wedge X-direction	Line	Line	Angularity	75	-0.500	0.500	75.548	0.548	High
BB2	Wedge Y-direction	Line	Line	Angularity	60	-0.500	0.500	60.330	0.330	Good
BB3	Wedge Y-direction	Line	Line	Angularity	75	-0.500	0.500	75.110	0.110	Good
CC1	Pyramid	Line	Line	Angularity	106.7	-0.500	0.500	107.155	0.455	Good
CC2	Pyramid	Line	Line	Angularity	106.7	-0.500	0.500	106.362	-0.338	Good
DD1	Pyramid	Line	Line	Angularity	111.8	-0.500	0.500	112.167	0.367	Good
DD2	Pyramid	Line	Line	Angularity	111.8	-0.500	0.500	111.292	-0.508	Low
T1	Triangular Hole	Line	Line	Perpendicularity		-0.500	0.500	0.048	0.048	Good
T2	Cylinder Hole/ Hollow Cylinder	Outer Circle	Inner Circle	Circularity		-0.500	0.500	0.048	0.048	Good
T3	Cylinder Hole/ Hollow Cylinder	Outer Circle	Inner Circle	Concentricity		-0.500	0.500	0.016	0.016	Good
T4	Cylinder Hole/ Hollow Cylinder	Outer Circle	Inner Circle	Circularity		-0.500	0.500	0.038	0.038	Good
T5	Square Base	Plane	Bottom Side	Flatness		-0.500	0.500	1.058	1.058	High
T6	Square Base	Left_Side	Bottom Side	Perpendicularity		-0.500	0.500	0.140	0.140	Good
T7	Square Base	Top_Side	Right Side	Perpendicularity		-0.500	0.500	0.009	0.009	Good
T8	Square Base	Left_Side	Right Side	Parallelism		-0.500	0.500	0.096	0.096	Good
T9	Square Base	Top_Side	Bottom Side	Parallelism		-0.500	0.500	0.245	0.245	Good
T10	Thin Walls	Line	Line	Parallelism		-0.500	0.500	0.204	0.204	Good
T11	Thin Walls	Line	Line	Parallelism		-0.500	0.500	0.111	0.111	Good
T12	Thin Walls	Line	Line	Thickness		-0.500	0.500	0.165	0.165	Good
T13	Thin Walls	Line	Line	Thickness		-0.500	0.500	0.162	0.162	Good
T14	Cube's 2,3,1	Cube231		Straightness		-0.500	0.500	0.049	0.049	Good



T41	Sphere	plane_2	Actual Sphere Axis	Axial runout		-0.500	0.500	0.951	0.951	High
		plane_2	Sphere	Symmetry tol. plane element		-0.500	0.500	2.857	2.857	
T42	Sphere	Theoretical Sphere Axis	Sphere	Symmetry tol. axis element		-0.500	0.500	1.248	1.248	High
T43	Sphere	Sphere Bottom Circle	Sphere	Symmetry tol. point element		-0.500	0.500	0.041	0.041	High
T47	Sphere	Actual Sphere Axis	Theoretical Sphere Axis	Coaxiality		-0.500	0.500	1.708	1.708	Good
T51	Sphere	Sphere	Sphere Bottom Circle	Concentricity		-0.500	0.500	0.045	0.045	High
T52	Sphere	Dome Bottom Circle	Actual Dome axis	Circular runout		-0.500	0.500	0.139	0.139	Good
T54	Dome	Dome Upper Circle	Actual Dome axis	Circular runout		-0.500	0.500	0.069	0.069	Good
T56	Dome	plane_2	Actual Dome axis	Axial runout		-0.500	0.500	5.023	5.023	High
T58										
		Dome Bottom Circle	Dome Upper Circle	Symmetry tol. point element		-0.500	0.500	0.527	0.527	
T65	Dome	plane_2	Actual Dome axis	Perpendicularity		-0.500	0.500	1.005	1.005	High
T67	Dome	Dome Upper Circle	Dome Bottom Circle	Concentricity		-0.500	0.500	0.567	0.567	High
T69	Dome	Sinkhole Upper Circle	Theoretical Sinkhole axis	Circular runout		-0.500	0.500	1.798	1.798	High
T70	Sinkhole	Sinkhole Upper Circle	Actual Sinkhole Axis	Circular runout		-0.500	0.500	0.159	0.159	Good
T71	Sinkhole	Sinkhole Bottom Circle	Theoretical Sinkhole axis	Circular runout		-0.500	0.500	1.321	1.321	High
T72	Sinkhole	Sinkhole Bottom Circle	Actual Sinkhole	Circular runout		-0.500	0.500	0.146	0.146	Good
T73	Sinkhole	Sinkhole Bottom Circle	Actual Sinkhole	Circular runout		-0.500	0.500	0.146	0.146	Good

	Circle	Axis	runout						
T79	Sinkhole Theoretical Sinkhole Axis	plane_2	Symmetry tol. axis element	-0.500	0.500	0.287	0.287		Good
T82	Sinkhole Sinkhole Bottom Circle	Sinkhole Bottom Circle	Symmetry tol. point element	-0.500	0.500	0.177	0.177		Good
T84	Sinkhole plane_2	Actual Sinkhole Axis	Perpendicularity	-0.500	0.500	1.472	1.472		High
T85	Sinkhole Actual Sinkhole Axis	Theoretical Sinkhole axis	Coaxiality	-0.500	0.500	1.929	1.929		High
T86	Sinkhole Sinkhole Bottom Circle	Sinkhole Lower Circle	Concentricity	-0.500	0.500	0.428	0.428		Good

### Feature Tolerances – Polyamide Titanium Casting

Feature Tolerances - Polyamide Casting Pattern 2										
Tolerance No.	Feature	Tol.ElemName	Compared to	Type of Tolerance	Spec.	Lower Tol.	Upper Tol.	Actual	Tol. Deviation	Result
A1	Square Base	Line	Point	Distance	58.92	-0.500	0.500	60.552	1.632	High
A2	Pattern	Line	Point	Distance	71.54	-0.500	0.500	70.562	-0.978	Low
A3	Pattern	Line	Point	Distance	2.1	-0.500	0.500	1.339	-0.761	Low
A4	Rectangular Protrosion	Line	Point	Distance	25.25	-0.500	0.500	24.735	-0.515	Low
A5	Rectangular Protrosion	Line	Point	Distance	8.42	-0.500	0.500	7.859	-0.561	Low
A6	Rectangular Protrosion	Line	Point	Distance	8.42	-0.500	0.500	8.152	-0.268	Good
A7	Pattern	Line	Point	Distance	8.42	-0.500	0.500	7.849	-0.571	Low

A8	Wedge X	Line	Point	Distance	12.63	-0.500	0.500	12.571	-0.059	Good
A9	Cube 1	Line	Point	Distance	8.42	-0.500	0.500	7.864	-0.556	Low
A10	Cube 1	Line	Point	Distance	8.42	-0.500	0.500	8.048	-0.372	Good
A11	Cube 1	Line	Point	Distance	8.42	-0.500	0.500	7.775	-0.645	Low
A12	Rectangular Hole	Line	Point	Distance	25.2	-0.500	0.500	25.548	0.348	Good
A13	Rectangular Hole	Line	Point	Distance	8.42	-0.500	0.500	8.585	0.165	Good
A14	Cube 2	Line	Point	Distance	8.42	-0.500	0.500	7.419	-1.001	Low
A15	Cube 2	Line	Point	Distance	8.42	-0.500	0.500	7.700	-0.720	Low
A16	Pattern	Line	Point	Distance	2.53	-0.500	0.500	1.361	-1.169	Low
B1	Square Base	Line	Point	Distance	151.5	-0.500	0.500	150.004	-1.496	Low
B2	Cube 1	Line	Point	Distance	8.42	-0.500	0.500	8.142	-0.278	Good
C1	Rectangular Protrusion	Line	Point	Distance	8.42	-0.500	0.500	8.217	-0.203	Good
C2	Pattern	Line	Point	Distance	1.68	-0.500	0.500	1.775	0.095	Good
C3	Rectangular Protrusion	Line	Point	Distance	25.25	-0.500	0.500	24.544	-0.706	Low
C4	Square Base	Line	Point	Distance	151.5	-0.500	0.500	150.004	-1.496	Low
C5	Wedge X	Line	Point	Distance	25.25	-0.500	0.500	24.176	-1.074	Low
C6	Cube 1	Line	Point	Distance	8.42	-0.500	0.500	7.720	-0.700	Low
CC3	Cube 1	Line	Point	Distance	8.42	-0.500	0.500	7.775	-0.645	Low
CC4	Cube 1	Line	Point	Distance	8.42	-0.500	0.500	8.048	-0.372	Good
CC5	Cylinder Depth	Line	Point	Distance	16.83	-0.500	0.500	16.873	0.043	Good
D1	Square Base Depth	Line	Point	Distance	29.46	-0.500	0.500	30.824	1.364	High
D2	Cube 3	Line	Point	Distance	4.21	-0.500	0.500	4.135	-0.075	Good
D3	Cube 3	Line	Point	Distance	8.42	-0.500	0.500	7.916	-0.504	Low
D4	Cube 2	Line	Point	Distance	8.42	-0.500	0.500	7.870	-0.550	Low
E1	Square Base	Line	Point	Distance	151.5	-0.500	0.500	150.242	-1.258	Low
E2	Wedge Y	Line	Point	Distance	25.25	-0.500	0.500	24.176	-1.074	Low
E3	Wedge Y	Line	Point	Distance	12.63	-0.500	0.500	12.081	-0.549	Low
E4	Wedge Y	Line	Point	Distance	6.73	-0.500	0.500	6.148	-0.582	Low
E5	Cube 4	Line	Point	Distance	8.42	-0.500	0.500	8.021	-0.399	Good

E6	Rectangular Hole	Line	Point	Distance	8.42	-0.500	0.500	8.591	0.171	Good
E7	Rectangular Hole	Line	Point	Distance	25.25	-0.500	0.500	25.523	0.273	Good
E8	Cube 3	Line	Point	Distance	8.42	-0.500	0.500	7.922	-0.498	Good
E9	Cube 3	Line	Point	Distance	8.42	-0.500	0.500	7.961	-0.459	Good
E10	Cylinder Inner Diameter	Line	Point	Distance	21.04	-0.500	0.500	21.075	0.035	Good
E11	Cylinder Outer Diameter	Line	Point	Distance	29.46	-0.500	0.500	29.306	-0.154	Good
E12	Square Base	Line	Point	Distance	151.5	-0.500	0.500	150.340	-1.160	Low
EE1	Triangular Hole	Line	Point	Distance	5.89	-0.500	0.500	5.807	-0.083	Good
EE2	Thin Walls	Line	Point	Distance	4.21	-0.500	0.500	4.078	-0.132	Good
EE3	Thin Walls	Line	Point	Distance	2.53	-0.500	0.500	2.462	-0.068	Good
AA2	Wedge X-direction	Line	Line	Angularity	75	-0.500	0.500	74.975	-0.025	Good
AA3	Wedge X-direction	Line	Line	Angularity	75	-0.500	0.500	75.000	0.000	Good
BB2	Wedge Y-direction	Line	Line	Angularity	60	-0.500	0.500	59.628	-0.372	Good
BB3	Wedge Y-direction	Line	Line	Angularity	75	-0.500	0.500	74.459	-0.541	Low
CC1	Pyramid	Line	Line	Angularity	106.7	-0.500	0.500	107.006	0.306	Good
CC2	Pyramid	Line	Line	Angularity	106.7	-0.500	0.500	106.729	0.029	Good
DD1	Pyramid	Line	Line	Angularity	111.8	-0.500	0.500	111.680	-0.120	Good
DD2	Pyramid	Line	Line	Angularity	111.8	-0.500	0.500	112.201	0.401	Good
T1	Triangular Hole	Line	Line	Perpendicularity		-0.500	0.500	0.774	0.774	High
T2	Cylinder Hole/ Hollow Cylinder	Outer Circle	Inner Circle	Circularity		-0.500	0.500	0.097	0.097	Good
T3	Cylinder Hole/ Hollow Cylinder	Outer Circle	Inner Circle	Concentricity		-0.500	0.500	0.073	0.073	Good
T4	Cylinder Hole/ Hollow Cylinder	Outer Circle	Inner Circle	Circularity		-0.500	0.500	0.028	0.028	Good
T5	Square Base	Plane		Flatness		-0.500	0.500	0.633	0.633	High
T6	Square Base	Left_Side	Bottom Side	Perpendicularity		-0.500	0.500	0.100	0.100	Good
T7	Square Base	Top_Side	Right Side	Perpendicularity		-0.500	0.500	0.082	0.082	Good
T8	Square Base	Left_Side	Right Side	Parallelism		-0.500	0.500	0.097	0.097	Good

	Top_Side	Bottom Side	Parallelism		-0.500	0.500	0.085	0.085	Good
T9	Square Base								
T10	Thin Walls	Line	Line	Parallelism	-0.500	0.500	0.037	0.037	Good
T11	Thin Walls	Line	Line	Parallelism	-0.500	0.500	0.014	0.014	Good
T12	Thin Walls	Line	Line	Thickness	-0.500	0.500	0.002	0.002	Good
T13	Thin Walls	Line	Line	Thickness	-0.500	0.500	0.016	0.016	Good
T14	Cube's 2,3,1	Cube231		Straightness	-0.500	0.500	0.006	0.006	Good
T15	Cube's 1,4, RecProtr	Cube14Rec		Straightness	-0.500	0.500	0.119	0.119	Good
T16	Rectangular Protrusion Outer	RecP2	RecP1	Perpendicularity	-0.500	0.500	0.200	0.200	Good
T17	Rectangular Protrusion Inner	RecP4	RecP3	Perpendicularity	-0.500	0.500	0.220	0.220	Good
T18	Rectangular Hole Outer	Rech4	Rech3	Perpendicularity	-0.500	0.500	0.210	0.210	Good
T19	Rectangular Hole Inner	Rech1	Rech2	Perpendicularity	-0.500	0.500	0.475	0.475	Good
T23	Cone	Actual Cone Axis	Cone	Symmetry tol. axis element	-0.500	0.500	0.079	0.079	Good
T24	Cone	Cone Bottom Circle	Cone	Circular runout	-0.500	0.500	0.119	0.119	Good
T26	Cone	Cone Bottom Circle	Theoretical Cone Axis	Circular runout	-0.500	0.500	1.046	1.046	High
T29	Cone	plane_2	Cone	Axial runout	-0.500	0.500	0.617	0.617	High
T31	Cone	Cone	plane_2	Symmetry tol. axis element	-0.500	0.500	0.090	0.090	Good
T32	Cone	Cone Bottom Circle	Cone	Symmetry tol. point element	-0.500	0.500	0.042	0.042	Good
T33	Cone	Cone	plane_2	Angularity	-0.500	0.500	0.028	0.028	Good
T34	Cone	Cone	Theoretical Cone Axis	Coaxiality	-0.500	0.500	1.065	1.065	High
T36	Cone	Cone	Actual Cone Axis	Coaxiality	-0.500	0.500	0.129	0.129	Good
T37	Cone	Cone_Bottom_Circle	Actual Cone Axis	Circular runout	-0.500	0.500	0.051	0.051	Good
T38	Sphere	Sphere Bottom Circle	Sphere Axis	Circular runout	-0.500	0.500	0.477	0.477	Good
T39	Sphere	Sphere Bottom Circle	Actual Sphere	Circular runout	-0.500	0.500	0.061	0.061	Good

T41	Sphere	plane_2	Axis Actual Sphere Axis	Axial runout	-0.500	0.500	0.874	0.874	High
T42	Sphere	plane_2	Sphere	Symmetry tol. plane element	-0.500	0.500	4.389	4.389	High
T43	Sphere	Theoretical Sphere Axis	Sphere	Symmetry tol. axis element	-0.500	0.500	0.051	0.051	Good
T47	Sphere	Sphere Bottom Circle	Sphere	Symmetry tol. point element	-0.500	0.500	0.030	0.030	Good
T51	Sphere	Actual Sphere Axis	Theoretical Sphere Axis	Coaxiality	-0.500	0.500	0.437	0.437	Good
T52	Sphere	Sphere	Sphere Bottom Circle	Concentricity	-0.500	0.500	0.048	0.048	Good
T54	Dome	Dome Bottom Circle	Actual Dome axis	Circular runout	-0.500	0.500	0.073	0.073	Good
T56	Dome	Dome Upper Circle	Actual Dome axis	Circular runout	-0.500	0.500	0.027	0.027	Good
T58	Dome	plane_2	Actual Dome axis	Axial runout	-0.500	0.500	0.495	0.495	Good
T65	Dome	Dome Bottom Circle	Dome Upper Circle	Symmetry tol. point element	-0.500	0.500	0.066	0.066	Good
T67	Dome	plane_2	Actual Dome axis	Perpendicularity	-0.500	0.500	0.099	0.099	Good
T69	Dome	Dome Upper Circle	Dome Bottom Circle	Concentricity	-0.500	0.500	0.073	0.073	Good
T70	Sinkhole	Sinkhole Upper Circle	Theoretical Sinkhole axis	Circular runout	-0.500	0.500	0.773	0.773	High
T71	Sinkhole	Sinkhole Upper Circle	Actual Sinkhole Axis	Circular runout	-0.500	0.500	0.126	0.126	Good

T72	Sinkhole	Sinkhole Bottom Circle	Theoretical Sinkhole axis	Circular runout		-0.500	0.500	0.887	0.887	High
T73	Sinkhole	Sinkhole Bottom Circle	Actual Sinkhole Axis	Circular runout		-0.500	0.500	0.058	0.058	Good
T79	Sinkhole	Theoretical Sinkhole Axis	plane_2	Symmetry tol. axis element		-0.500	0.500	0.020	0.020	Good
T82	Sinkhole	Sinkhole Bottom Circle	Sinkhole Bottom Circle	Symmetry tol. point element		-0.500	0.500	0.133	0.133	Good
T84	Sinkhole	plane_2	Actual Sinkhole Axis	Perpendicularity		-0.500	0.500	0.667	0.667	High
T85	Sinkhole	Actual Sinkhole Axis	Theoretical Sinkhole axis	Coaxiality		-0.500	0.500	0.742	0.742	High
T86	Sinkhole	Sinkhole Bottom Circle	Sinkhole Lower Circle	Concentricity		-0.500	0.500	0.181	0.181	Good

*Appendix I      Titanium Castings -  
Statistical CMM Raw  
Data (3D-Tol Data)*

### 3D-Tol Data from CMM for 3DP Titanium Casting

MEAS X	MEAS Y	MEAS Z	CAD X	CAD Y	CAD Z	DIF X	DIF Y	DIF Z	TOT DIF
53.768	58.902	-5.832	53.768	58.917	-5.832	0	-0.015	0	-0.015
37.224	59.053	-5.836	37.224	58.917	-5.836	0	0.136	0	0.136
20.68	59.012	-5.84	20.68	58.917	-5.84	0	0.096	0	0.096
4.135	58.939	-5.846	4.135	58.917	-5.846	0	0.022	0	0.022
-12.411	59.002	-5.851	-12.411	58.917	-5.851	0	0.085	0	0.085
-28.957	59.284	-5.856	-28.957	58.917	-5.856	0	0.367	0	0.367
-45.5	59.044	-5.862	-45.5	58.917	-5.862	0	0.127	0	0.127
-62.046	59.028	-5.867	-62.046	58.917	-5.867	0	0.111	0	0.111
-80.124	40.981	-5.881	-79.958	40.981	-5.881	-0.166	0	0	0.166
-80.143	24.437	-5.888	-79.958	24.437	-5.888	-0.184	0	0	0.184
-80.201	7.89	-5.89	-79.958	7.89	-5.89	-0.243	0	0	0.243
-80.235	-8.655	-5.895	-79.958	-8.655	-5.895	-0.277	0	0	0.277
-80.15	-25.199	-5.899	-79.958	-25.199	-5.899	-0.192	0	0	0.192
-80.056	-41.745	-5.905	-79.958	-41.745	-5.905	-0.097	0	0	0.097
-80.032	-58.289	-5.909	-79.958	-58.289	-5.909	-0.074	0	0	0.074
-79.92	-74.832	-5.914	-79.958	-74.832	-5.914	0.038	0	0	-0.038
-61.995	-92.739	-5.915	-61.995	-92.583	-5.915	0	-0.156	0	0.156
-45.449	-92.79	-5.908	-45.449	-92.583	-5.908	0	-0.207	0	0.207
-28.905	-92.634	-5.904	-28.905	-92.583	-5.904	0	-0.051	0	0.051
-12.36	-92.802	-5.898	-12.36	-92.583	-5.898	0	-0.219	0	0.219
4.184	-92.798	-5.893	4.184	-92.583	-5.893	0	-0.215	0	0.215
20.73	-92.83	-5.888	20.73	-92.583	-5.888	0	-0.247	0	0.247
37.274	-92.686	-5.882	37.274	-92.583	-5.882	0	-0.103	0	0.103
53.818	-92.725	-5.876	53.818	-92.583	-5.876	0	-0.141	0	0.141
71.331	-74.784	-5.865	71.542	-74.784	-5.865	-0.211	0	0	-0.211
71.57	-58.238	-5.859	71.542	-58.238	-5.859	0.029	0	0	0.029
71.7	-41.694	-5.854	71.542	-41.694	-5.854	0.158	0	0	0.158
71.57	-25.149	-5.85	71.542	-25.149	-5.85	0.028	0	0	0.028
71.671	-8.604	-5.845	71.542	-8.604	-5.845	0.129	0	0	0.129
71.704	7.941	-5.84	71.542	7.941	-5.84	0.162	0	0	0.162
71.694	24.485	-5.835	71.542	24.485	-5.835	0.152	0	0	0.152
71.65	41.029	-5.83	71.542	41.029	-5.83	0.109	0	0	0.109
-69.786	43.674	8.509	-69.786	43.674	8.417	0	0	0.092	0.092
-64.734	43.676	8.55	-64.734	43.676	8.417	0	0	0.133	0.133
-64.738	48.726	8.569	-64.738	48.726	8.417	0	0	0.152	0.152
-69.788	48.723	8.427	-69.788	48.723	8.417	0	0	0.01	0.01
-67.656	46.319	8.396	-67.656	46.319	8.417	0	0	-0.02	-0.02
-71.613	43.673	6.747	-71.542	43.673	6.747	-0.071	0	0	0.071
-71.964	48.723	6.75	-71.542	48.723	6.75	-0.423	0	0	0.423

-69.788	50.591	6.752	-69.788	50.5	6.752	0	0.091	0	0.091
-64.738	50.538	6.752	-64.738	50.5	6.752	0	0.038	0	0.038
-64.735	42.666	6.749	-64.735	42.083	6.749	0	0.583	0	-0.583
-69.784	42.668	6.748	-69.784	42.083	6.748	0	0.585	0	-0.585
-63.064	49.703	6.752	-63.125	50.5	6.752	0.061	-0.797	0	0.8
-63.119	42.698	6.751	-63.125	42.083	6.751	0.006	0.615	0	0.615
-64.717	-14.399	4.173	-64.717	-14.399	4.208	0	0	-0.035	-0.035
-69.767	-14.401	4.129	-69.767	-14.401	4.208	0	0	-0.079	-0.079
-69.764	-19.451	4.106	-69.764	-19.451	4.208	0	0	-0.102	-0.102
-64.715	-19.449	4.196	-64.715	-19.449	4.208	0	0	-0.013	-0.013
-67.888	-16.824	4.061	-67.888	-16.824	4.208	0	0	-0.147	-0.147
-69.769	-12.472	3.367	-69.769	-12.625	3.367	0	0.153	0	0.153
-64.717	-12.542	3.369	-64.717	-12.625	3.369	0	0.083	0	0.083
-63.142	-14.397	4.337	-63.125	-14.397	4.208	-0.017	0	0.128	-0.13
-63.152	-19.447	4.314	-63.125	-19.447	4.208	-0.027	0	0.106	-0.109
-64.714	-21.092	4.142	-64.714	-21.042	4.208	0	-0.051	-0.066	0.084
-69.764	-21.164	4.078	-69.764	-21.042	4.208	0	-0.122	-0.131	0.179
-71.724	-19.45	3.363	-71.542	-19.45	3.363	-0.182	0	0	0.182
-71.892	-14.4	3.365	-71.542	-14.4	3.365	-0.35	0	0	0.35
-64.699	-77.525	8.498	-64.699	-77.525	8.417	0	0	0.082	0.082
-69.749	-77.527	8.427	-69.749	-77.527	8.417	0	0	0.011	0.011
-69.748	-82.576	8.418	-69.748	-82.576	8.417	0	0	0.001	0.001
-64.697	-82.574	8.468	-64.697	-82.574	8.417	0	0	0.051	0.051
-69.75	-75.928	6.715	-69.75	-75.75	6.715	0	-0.178	0	-0.178
-64.699	-76.081	6.716	-64.699	-75.75	6.716	0	-0.331	0	-0.331
-63.064	-77.523	7.69	-63.125	-77.523	8.417	0.061	0	-0.727	0.729
-63.088	-83.55	6.713	-63.125	-84.167	6.713	0.037	0.617	0	0.618
-64.695	-84.041	6.712	-64.695	-84.167	6.712	0	0.126	0	-0.126
-69.747	-84.169	6.711	-69.747	-84.167	6.711	0	-0.002	0	0.002
-71.45	-82.577	6.711	-71.542	-82.577	6.711	0.092	0	0	-0.092
-71.63	-77.527	6.714	-71.542	-77.527	6.714	-0.088	0	0	0.088
-2.452	43.695	3.95	-2.452	43.695	4.208	0	0	-0.258	-0.258
2.599	43.697	4.022	2.599	43.697	4.208	0	0	-0.186	-0.186
2.596	48.748	4.095	2.596	48.748	4.208	0	0	-0.114	-0.114
-2.453	48.745	4.005	-2.453	48.745	4.208	0	0	-0.204	-0.204
-0.613	46.73	3.911	-0.613	46.73	4.208	0	0	-0.297	-0.297
-4.083	43.696	2.141	-4.208	43.696	2.141	0.126	0	0	-0.126
-4.195	48.746	2.143	-4.208	48.746	2.143	0.013	0	0	-0.013
2.6	42.679	2.142	2.6	42.083	2.142	0	0.596	0	-0.596
-2.449	42.664	2.141	-2.449	42.083	2.141	0	0.58	0	-0.58
3.94	48.75	2.145	4.208	48.75	2.145	-0.269	0	0	-0.269

3.847	43.699	2.144	4.208	43.699	2.144	-0.361	0	0	-0.361
-2.457	50.821	2.144	-2.457	50.5	2.144	0	0.321	0	0.321
2.596	50.779	2.146	2.596	50.5	2.146	0	0.279	0	0.279
-64.739	36.163	-0.297	-64.788	36.212	0	0.049	-0.049	-0.297	0.305
-53.993	46.842	-0.32	-54.075	46.925	0	0.082	-0.082	-0.32	0.341
-46.831	46.87	-1.239	-46.851	46.851	-1.239	0.02	0.02	0	-0.028
-35.945	36.33	-1.238	-36.137	36.137	-1.238	0.192	0.192	0	-0.272
-41.124	28.77	-1.241	-40.898	28.995	-1.241	-0.225	-0.225	0	-0.319
-48.305	35.874	-1.241	-48.041	36.138	-1.241	-0.264	-0.264	0	-0.373
-35.915	29.752	-1.62	-35.727	29.564	-1.62	-0.188	0.188	0	0.266
-54.235	35.177	-1.244	-54.077	35.02	-1.244	-0.158	0.158	0	0.223
-58.951	30.38	-1.246	-58.834	30.263	-1.246	-0.117	0.117	0	0.165
-65.182	29.655	-0.268	-65.273	29.564	0	0.091	0.091	-0.268	0.298
-61.316	33.473	-4.075	-61.316	33.473	-4.208	0	0	0.134	0.134
-56.749	38.23	-3.943	-56.749	38.23	-4.208	0	0	0.265	0.265
-50.255	43.635	-3.925	-50.255	43.635	-4.208	0	0	0.283	0.283
-44.694	38.588	-4.001	-44.694	38.588	-4.208	0	0	0.207	0.207
-40.016	33.782	-4.112	-40.016	33.782	-4.208	0	0	0.097	0.097
49.732	42.339	5.945	49.732	42.083	5.945	0	0.255	0	-0.255
42.998	42.53	5.944	42.998	42.083	5.944	0	0.446	0	-0.446
55.248	30.246	5.944	54.708	30.246	5.944	0.54	0	0	-0.54
55.028	36.979	5.947	54.708	36.979	5.947	0.32	0	0	-0.32
58.877	25.575	5.448	58.877	25.25	5.448	0	0.325	0	-0.325
63.282	30.25	5.947	63.125	30.25	5.947	0.157	0	0	0.157
63.27	37.826	5.949	63.125	37.826	5.949	0.145	0	0	0.145
62.985	45.4	5.951	63.125	45.4	5.951	-0.14	0	0	-0.14
58.144	50.758	5.952	58.144	50.5	5.952	0	0.258	0	0.258
50.568	50.948	5.95	50.568	50.5	5.95	0	0.448	0	0.448
42.994	50.905	5.948	42.994	50.5	5.948	0	0.405	0	0.405
38.375	46.183	5.226	37.875	46.183	5.226	0.5	0	0	-0.5
43.246	46.353	8.486	43.246	46.353	8.417	0	0	0.069	0.069
50.479	46.064	8.455	50.479	46.064	8.417	0	0	0.038	0.038
58.45	45.735	8.495	58.45	45.735	8.417	0	0	0.078	0.078
59.193	37.471	8.57	59.193	37.471	8.417	0	0	0.154	0.154
59.072	30.625	8.544	59.072	30.625	8.417	0	0	0.128	0.128
-30.835	48.972	16.881	-30.835	48.858	16.947	0	0.114	-0.066	-0.131
-30.832	46.132	11.824	-30.832	45.959	11.924	0	0.173	-0.1	-0.2
-30.829	43.356	6.721	-30.829	43.055	6.895	0	0.301	-0.174	-0.347
-30.827	40.358	1.753	-30.827	40.154	1.871	0	0.204	-0.118	-0.235
-27.038	40.342	1.766	-27.038	40.156	1.874	0	0.186	-0.107	-0.215
-27.042	43.442	6.676	-27.042	43.057	6.898	0	0.385	-0.222	-0.444

-27.045	46.223	11.77	-27.045	45.958	11.923	0	0.265	-0.153	-0.306
-27.047	48.939	16.901	-27.047	48.859	16.948	0	0.08	-0.046	-0.093
-23.259	49.051	16.843	-23.259	48.862	16.952	0	0.189	-0.109	-0.218
-23.256	46.254	11.754	-23.256	45.959	11.925	0	0.295	-0.17	-0.341
-23.255	43.495	6.645	-23.255	43.057	6.898	0	0.439	-0.253	-0.507
-23.252	40.51	1.665	-23.252	40.154	1.871	0	0.356	-0.206	-0.411
-16.942	45.828	1.786	-16.942	45.414	1.897	0	0.414	-0.111	-0.429
-16.944	47.877	9.318	-16.944	47.434	9.437	0	0.443	-0.119	-0.458
-16.948	49.714	16.904	-16.948	49.453	16.973	0	0.26	-0.07	-0.269
-11.898	49.929	17.357	-11.898	50.326	17.464	0	-0.397	-0.106	0.411
-11.895	47.771	9.349	-11.895	47.434	9.439	0	0.337	-0.09	-0.349
-11.891	45.895	1.77	-11.891	45.414	1.899	0	0.481	-0.129	-0.498
-9.069	49.544	7.563	-8.178	49.544	7.563	-0.891	0	0	-0.891
-30.838	51.321	15.224	-30.838	50.952	15.125	0	0.369	0.099	0.382
-30.836	52.655	9.524	-30.836	52.467	9.474	0	0.188	0.05	0.195
-30.834	54.194	3.876	-30.834	53.982	3.819	0	0.212	0.057	0.22
-24.1	54.201	3.88	-24.1	53.981	3.821	0	0.219	0.059	0.227
-24.1	52.75	9.551	-24.1	52.466	9.475	0	0.283	0.076	0.293
-24.102	51.343	15.235	-24.102	50.951	15.13	0	0.392	0.105	0.405
-17.369	51.403	15.25	-17.369	50.952	15.128	0	0.452	0.121	0.468
-17.369	52.869	9.584	-17.369	52.466	9.476	0	0.403	0.108	0.417
-17.368	54.365	3.924	-17.368	53.981	3.821	0	0.384	0.103	0.397
-10.634	54.322	3.916	-10.634	53.98	3.825	0	0.342	0.092	0.354
-10.634	52.9	9.594	-10.634	52.466	9.477	0	0.434	0.116	0.449
-10.636	51.417	15.256	-10.636	50.951	15.131	0	0.466	0.125	0.482
-33.51	48.876	9.701	-33.428	48.876	9.701	-0.082	0	0	0.082
5.165	-63.2	18.852	5.059	-63.2	18.881	0.106	0	-0.028	-0.109
3.3	-63.198	11.777	3.165	-63.198	11.813	0.135	0	-0.036	-0.139
1.27	-63.197	4.745	1.271	-63.197	4.745	-0.002	0	0	0.002
1.557	-69.93	4.668	1.271	-69.93	4.745	0.285	0	-0.076	-0.295
3.35	-69.931	11.762	3.165	-69.931	11.812	0.185	0	-0.05	-0.192
5.244	-69.934	18.83	5.059	-69.934	18.88	0.185	0	-0.05	-0.192
5.206	-76.667	18.837	5.058	-76.667	18.877	0.148	0	-0.04	-0.153
3.352	-76.666	11.759	3.164	-76.666	11.809	0.188	0	-0.05	-0.194
1.491	-76.663	4.684	1.271	-76.663	4.743	0.22	0	-0.059	-0.227
1.556	-83.397	4.666	1.271	-83.397	4.743	0.285	0	-0.076	-0.295
3.326	-83.397	11.766	3.164	-83.397	11.81	0.161	0	-0.043	-0.167
5.255	-83.399	18.825	5.058	-83.399	18.878	0.197	0	-0.053	-0.204
7.572	-85.91	10.364	7.572	-85.85	10.364	0	-0.06	0	0.06
7.725	-83.396	21.174	7.698	-83.396	21.159	0.027	0	0.015	0.031
12.897	-83.392	11.596	13.139	-83.392	11.736	-0.241	0	-0.139	-0.279

18.462	-83.387	2.243	18.58	-83.387	2.311	-0.118	0	-0.068	-0.136
18.456	-75.813	2.245	18.577	-75.813	2.315	-0.122	0	-0.07	-0.14
12.91	-75.818	11.609	13.136	-75.818	11.74	-0.226	0	-0.131	-0.261
7.622	-75.822	21.118	7.697	-75.822	21.161	-0.075	0	-0.043	-0.086
6.919	-69.507	21.176	6.949	-69.507	21.184	-0.029	0	-0.008	-0.03
9.172	-69.505	11.68	9.474	-69.505	11.761	-0.302	0	-0.081	-0.313
11.728	-69.502	2.266	11.998	-69.502	2.338	-0.271	0	-0.073	-0.28
11.689	-64.452	2.257	11.998	-64.452	2.34	-0.309	0	-0.083	-0.32
9.129	-64.456	11.671	9.473	-64.456	11.763	-0.344	0	-0.092	-0.356
6.849	-64.459	21.16	6.948	-64.459	21.186	-0.099	0	-0.027	-0.102
6.545	-60.844	11.121	6.545	-60.6	11.121	0	-0.244	0	-0.244
-30.411	-50.729	-5.214	-30.424	-50.507	-5.46	0.013	-0.221	0.246	0.331
-30.121	-55.227	-7.649	-30.127	-55.115	-7.86	0.006	-0.112	0.211	0.239
-29.879	-58.862	-11.478	-29.893	-58.571	-11.631	0.014	-0.291	0.153	0.329
-29.679	-61.939	-15.435	-29.693	-61.606	-15.909	0.014	-0.333	0.474	0.579
-33.498	-63.683	-15.591	-33.676	-63.521	-15.941	0.179	-0.162	0.351	0.425
-35.875	-61.56	-11.587	-35.971	-61.474	-11.655	0.096	-0.086	0.068	0.146
-38.503	-59.212	-7.803	-38.534	-59.184	-7.881	0.031	-0.028	0.078	0.088
-41.894	-56.174	-5.372	-41.974	-56.102	-5.494	0.08	-0.072	0.121	0.162
-46.32	-68.2	-5.527	-46.273	-68.198	-5.475	-0.046	-0.002	-0.052	-0.07
-41.72	-67.985	-7.999	-41.653	-67.982	-7.873	-0.067	-0.004	-0.126	-0.143
-38.438	-67.838	-11.771	-38.208	-67.825	-11.65	-0.231	-0.013	-0.121	-0.261
-35.276	-67.689	-16.076	-35.166	-67.682	-15.919	-0.11	-0.007	-0.157	-0.192
-33.378	-71.779	-16.064	-33.285	-71.674	-15.87	-0.093	-0.105	-0.194	-0.24
-35.527	-74.093	-11.774	-35.325	-73.868	-11.615	-0.202	-0.225	-0.159	-0.342
-37.781	-76.514	-8.062	-37.703	-76.427	-7.84	-0.079	-0.087	-0.222	-0.251
-40.89	-79.865	-5.498	-40.844	-79.815	-5.423	-0.046	-0.051	-0.075	-0.101
-29.459	-67.502	-17.218	-29.553	-67.506	-16.861	0.093	0.003	-0.357	-0.369
-26.733	-62.658	-15.323	-26.536	-62.321	-15.859	-0.196	-0.337	0.536	0.663
-25.274	-59.976	-11.432	-25.113	-59.695	-11.603	-0.16	-0.282	0.171	0.366
-23.492	-56.698	-7.66	-23.447	-56.618	-7.834	-0.044	-0.079	0.173	0.196
-21.352	-52.774	-5.157	-21.236	-52.565	-5.416	-0.116	-0.209	0.258	0.352
-13.233	-62.683	-5.253	-13.143	-62.657	-5.35	-0.09	-0.026	0.097	0.135
-17.646	-63.976	-7.658	-17.576	-63.957	-7.799	-0.07	-0.02	0.141	0.158
-21.223	-65.031	-11.429	-20.976	-64.962	-11.565	-0.247	-0.069	0.136	0.29
-23.992	-65.846	-15.517	-23.785	-65.79	-15.801	-0.207	-0.056	0.284	0.356
-24.373	-70.121	-15.624	-24.271	-70.176	-15.774	-0.101	0.056	0.15	0.19
-21.641	-71.615	-11.214	-21.585	-71.646	-11.249	-0.056	0.031	0.035	0.073
-18.587	-73.285	-7.79	-18.591	-73.283	-7.78	0.004	-0.002	-0.01	-0.011
-14.462	-75.54	-5.425	-14.547	-75.493	-5.325	0.085	-0.047	-0.099	-0.139
-24.58	-83.627	-5.382	-24.59	-83.595	-5.347	0.009	-0.032	-0.034	-0.048

-25.862	-79.258	-7.965	-25.888	-79.173	-7.792	0.026	-0.085	-0.173	-0.194
-26.822	-75.973	-11.679	-26.887	-75.759	-11.562	0.065	-0.213	-0.118	-0.252
-27.722	-72.906	-15.728	-27.707	-72.955	-15.795	-0.015	0.048	0.067	0.084
-32.372	-72.551	-16.079	-32.244	-72.433	-15.853	-0.128	-0.118	-0.226	-0.286
-33.877	-75.27	-11.754	-33.672	-75.047	-11.6	-0.205	-0.223	-0.155	-0.34
-35.427	-78.188	-7.994	-35.355	-78.128	-7.827	-0.072	-0.061	-0.168	-0.193
-37.721	-82.327	-5.622	-37.568	-82.179	-5.403	-0.153	-0.148	-0.218	-0.305
-25.259	-86.579	-0.909	-25.321	-86.296	-0.544	0.062	-0.282	-0.366	-0.466
-12.775	-77.358	-0.951	-12.979	-77.235	-0.704	0.203	-0.122	-0.247	-0.343
-10.972	-61.852	-0.741	-11.016	-61.865	-0.693	0.044	0.013	-0.048	-0.067
-16.077	-53.691	-0.577	-15.994	-53.606	-0.701	-0.083	-0.085	0.124	0.172
-25.713	-48.462	-0.431	-25.688	-48.34	-0.58	-0.024	-0.122	0.15	0.194
-47.739	-38.093	18.547	-47.15	-37.835	18.918	-0.589	-0.258	-0.371	-0.742
-44.35	-36.501	12.29	-43.855	-36.275	12.604	-0.495	-0.225	-0.314	-0.628
-40.97	-34.905	6.027	-40.559	-34.715	6.288	-0.411	-0.19	-0.261	-0.523
-40.154	-41.306	6.018	-39.738	-41.387	6.262	-0.416	0.081	-0.244	-0.489
-43.696	-40.64	12.355	-43.321	-40.714	12.576	-0.376	0.074	-0.221	-0.442
-47.457	-39.928	18.563	-46.903	-40.042	18.889	-0.554	0.114	-0.327	-0.653
-48.081	-41.853	18.789	-47.971	-41.969	18.881	-0.11	0.116	-0.092	-0.185
-45.521	-44.555	12.522	-45.465	-44.615	12.569	-0.056	0.06	-0.047	-0.095
-43.064	-47.153	6.167	-42.959	-47.263	6.254	-0.104	0.11	-0.088	-0.175
-49.025	-50.081	6.222	-49.015	-50.159	6.267	-0.011	0.078	-0.045	-0.09
-49.495	-46.472	12.54	-49.485	-46.544	12.581	-0.01	0.072	-0.042	-0.084
-49.954	-42.996	18.929	-49.963	-42.931	18.892	0.01	-0.064	0.038	0.075
-52.264	-42.745	19.044	-52.166	-42.553	18.919	-0.098	-0.191	0.124	0.248
-53.928	-45.813	12.643	-53.899	-45.759	12.608	-0.028	-0.054	0.035	0.07
-55.671	-49.017	6.332	-55.641	-48.961	6.295	-0.03	-0.056	0.037	0.073
-51.929	-40.067	22.839	-51.777	-39.985	22.74	-0.152	-0.082	0.1	0.199
-57.33	-42.661	12.832	-57.033	-42.514	12.64	-0.298	-0.147	0.192	0.383
-62.69	-45.206	2.791	-62.3	-45.017	2.541	-0.39	-0.189	0.25	0.501
-63.69	-36.886	2.751	-63.381	-36.943	2.569	-0.309	0.057	0.181	0.363
-57.866	-37.979	12.797	-57.649	-38.018	12.67	-0.217	0.039	0.127	0.254
-52.051	-39.056	22.846	-51.916	-39.077	22.767	-0.135	0.021	0.079	0.157
-51.498	-38.24	22.796	-51.478	-38.261	22.779	-0.02	0.022	0.017	0.034
-55.615	-33.871	12.794	-55.477	-34.018	12.678	-0.138	0.146	0.116	0.232
-59.643	-29.605	2.717	-59.48	-29.778	2.579	-0.163	0.173	0.137	0.275
-52.098	-26.296	2.57	-52.097	-26.302	2.567	-0.001	0.006	0.003	0.007
-51.354	-32.11	12.657	-51.357	-32.088	12.67	0.003	-0.022	-0.013	-0.026
-50.613	-38.058	22.661	-50.63	-37.873	22.768	0.017	-0.185	-0.107	-0.214
-50.174	-38.354	22.47	-49.805	-38.027	22.738	-0.37	-0.327	-0.268	-0.562
-47.17	-33.099	12.5	-47.009	-32.911	12.639	-0.16	-0.188	-0.14	-0.284

-44.324	-27.928	2.44	-44.214	-27.793	2.539	-0.111	-0.135	-0.099	-0.201
-46.042	3.723	25.293	-46.166	3.84	25.129	0.123	-0.116	0.164	0.236
-50.328	7.765	27.789	-50.275	7.715	27.54	-0.053	0.05	0.249	0.259
-54.023	11.249	22.1	-53.739	10.981	21.928	-0.284	0.268	0.172	0.427
-56.659	13.746	8.355	-56.448	13.547	8.302	-0.211	0.199	0.053	0.295
-62.243	-1.732	8.377	-61.758	-1.69	8.288	-0.484	-0.042	0.089	0.494
-58.508	-1.43	22.112	-58.045	-1.39	21.908	-0.462	-0.04	0.204	0.507
-53.408	-1.018	27.814	-53.323	-1.01	27.531	-0.085	-0.008	0.283	0.296
-47.533	-0.551	25.293	-47.68	-0.566	25.15	0.146	0.015	0.143	0.205
-45.207	-4.322	25.528	-45.405	-4.595	25.197	0.198	0.274	0.331	0.473
-48.9	-9.123	27.623	-48.878	-9.094	27.51	-0.022	-0.029	0.113	0.118
-51.843	-12.972	21.959	-51.725	-12.816	21.873	-0.118	-0.156	0.086	0.214
-54.013	-15.825	8.284	-53.972	-15.771	8.272	-0.04	-0.054	0.012	0.068
-38.423	-19.081	8.201	-38.362	-19.399	8.26	-0.061	0.318	-0.059	-0.329
-39.085	-15.594	21.775	-39.053	-15.76	21.848	-0.032	0.166	-0.074	-0.184
-39.913	-11.199	27.487	-39.913	-11.2	27.491	0	0.001	-0.004	-0.005
-41.066	-5.023	25.802	-40.951	-5.591	25.231	-0.115	0.568	0.571	0.814
-40.225	19.878	8.343	-40.245	19.659	8.303	0.02	0.219	0.04	0.224
-40.573	16.02	21.953	-40.58	15.946	21.921	0.007	0.074	0.033	0.081
-40.997	11.264	27.676	-41.001	11.222	27.534	0.004	0.042	0.141	0.148
-41.513	5.283	25.451	-41.48	5.591	25.149	-0.033	-0.309	0.302	0.433
-38.838	4.036	25.638	-38.542	4.404	25.177	-0.296	-0.368	0.461	0.66
-35.121	8.95	27.596	-35.135	8.931	27.521	0.014	0.018	0.074	0.078
-32.41	12.514	21.809	-32.282	12.679	21.9	-0.128	-0.165	-0.092	-0.228
-30.223	15.385	8.235	-30.028	15.639	8.294	-0.196	-0.254	-0.059	-0.326
-23.977	6.651	8.197	-23.546	6.809	8.281	-0.431	-0.158	-0.084	-0.467
-27.502	5.334	21.656	-27.024	5.509	21.879	-0.478	-0.175	-0.223	-0.556
-31.402	3.875	27.503	-31.401	3.876	27.506	-0.001	0	-0.003	-0.003
-37.199	1.687	25.71	-36.714	1.854	25.207	-0.485	-0.167	0.503	0.719
-37.063	-1.128	25.779	-36.519	-1.25	25.23	-0.543	0.122	0.549	0.782
-30.956	-2.382	27.421	-30.932	-2.387	27.493	-0.024	0.005	-0.072	-0.076
-26.9	-3.22	21.629	-26.388	-3.329	21.858	-0.512	0.109	-0.228	-0.571
-23.152	-3.994	8.196	-22.758	-4.077	8.27	-0.394	0.083	-0.074	-0.409
-28.126	-13.454	8.196	-27.862	-13.708	8.263	-0.263	0.254	-0.067	-0.372
-30.724	-10.961	21.732	-30.534	-11.144	21.847	-0.19	0.183	-0.115	-0.288
-33.847	-7.955	27.583	-33.87	-7.932	27.488	0.023	-0.023	0.095	0.1
-38.414	-3.555	25.832	-37.982	-3.974	25.238	-0.432	0.419	0.594	0.845
-42.043	5.317	25.439	-42.041	5.62	25.145	-0.002	-0.303	0.294	0.422
-42.118	11.318	27.7	-42.118	11.269	27.536	0	0.049	0.164	0.171
-42.161	16.188	21.996	-42.16	16.017	21.921	-0.001	0.172	0.076	0.188
-42.191	19.958	8.343	-42.19	19.744	8.304	-0.001	0.213	0.039	0.217

-41.687	-0.944	21.015	-41.107	-1.787	20.381	-0.58	0.843	0.634	1.204
-44.801	0.121	21.701	-44.919	0.127	21.622	0.118	-0.005	0.079	0.142
-41.002	-1.896	21.786	-40.739	-2.357	21.434	-0.263	0.46	0.352	0.636
45.181	-41.388	15.313	45.192	-41.364	15.136	-0.012	-0.024	0.177	0.178
42.525	-46.252	13.465	42.563	-46.18	13.313	-0.038	-0.072	0.152	0.173
40.357	-50.223	9.8	40.386	-50.168	9.744	-0.029	-0.055	0.056	0.084
38.913	-52.867	4.849	38.916	-52.862	4.847	-0.002	-0.004	0.002	0.005
32.11	-44.771	4.743	31.818	-44.887	4.871	0.292	0.116	-0.129	-0.34
34.803	-43.717	9.676	34.696	-43.759	9.779	0.106	0.042	-0.104	-0.154
38.92	-42.107	13.401	38.949	-42.095	13.343	-0.029	-0.012	0.058	0.066
44.064	-40.095	15.199	44.071	-40.092	15.146	-0.007	-0.003	0.053	0.054
44.022	-38.392	15.203	44.029	-38.394	15.152	-0.007	0.002	0.051	0.052
38.835	-36.645	13.311	38.811	-36.637	13.36	0.024	-0.008	-0.048	-0.054
34.608	-35.217	9.669	34.472	-35.171	9.8	0.136	-0.046	-0.13	-0.194
31.87	-34.294	4.74	31.531	-34.18	4.887	0.339	-0.114	-0.147	-0.386
38.431	-26.138	4.729	38.233	-25.811	4.886	0.198	-0.328	-0.157	-0.414
39.919	-28.584	9.671	39.846	-28.462	9.8	0.073	-0.121	-0.129	-0.191
42.236	-32.39	13.318	42.225	-32.372	13.358	0.011	-0.018	-0.04	-0.045
45.081	-37.057	15.25	45.089	-37.07	15.151	-0.007	0.012	0.099	0.1
46.758	-36.719	15.244	46.755	-36.734	15.143	0.003	0.015	0.101	0.102
47.596	-31.203	13.534	47.579	-31.307	13.336	0.017	0.105	0.198	0.225
48.267	-26.777	9.792	48.263	-26.798	9.772	0.003	0.022	0.02	0.029
48.721	-23.798	4.85	48.729	-23.748	4.871	-0.008	-0.05	-0.021	-0.055
38.917	-52.865	4.85	38.918	-52.863	4.849	-0.001	-0.002	0.001	0.003
40.359	-50.219	9.797	40.387	-50.168	9.745	-0.028	-0.052	0.053	0.079
42.529	-46.249	13.459	42.565	-46.18	13.314	-0.037	-0.069	0.145	0.165
45.181	-41.387	15.303	45.192	-41.364	15.136	-0.011	-0.022	0.167	0.168
47.58	-36.995	15.259	47.571	-37.011	15.138	0.009	0.015	0.121	0.122
50.238	-32.127	13.469	50.199	-32.197	13.32	0.039	0.07	0.149	0.169
52.403	-28.167	9.795	52.38	-28.207	9.754	0.022	0.04	0.041	0.062
53.737	-25.493	4.841	53.762	-25.458	4.858	-0.025	-0.034	-0.017	-0.046
60.872	-33.516	4.846	60.841	-33.528	4.833	0.031	0.012	0.013	0.035
58.045	-34.623	9.764	57.998	-34.641	9.719	0.047	0.018	0.045	0.067
53.856	-36.265	13.431	53.785	-36.292	13.291	0.071	0.027	0.14	0.159
48.705	-38.278	15.24	48.689	-38.284	15.128	0.016	0.006	0.113	0.114
48.746	-39.988	15.247	48.728	-39.981	15.122	0.018	-0.006	0.125	0.126
54.019	-41.763	13.485	53.91	-41.726	13.273	0.109	-0.037	0.212	0.241
58.34	-43.217	9.846	58.184	-43.164	9.699	0.156	-0.053	0.147	0.221
61.368	-44.236	4.947	61.066	-44.134	4.818	0.303	-0.102	0.13	0.345
54.625	-52.705	4.952	54.452	-52.425	4.819	0.172	-0.281	0.134	0.355
53.002	-50.043	9.932	52.867	-49.825	9.703	0.134	-0.218	0.229	0.343

50.603	-46.111	13.581	50.516	-45.971	13.278	0.087	-0.14	0.303	0.345
47.695	-41.342	15.413	47.671	-41.304	15.123	0.024	-0.038	0.289	0.293
46.006	-41.662	15.284	46.009	-41.639	15.131	-0.003	-0.023	0.153	0.155
45.175	-47.14	13.457	45.187	-47.055	13.299	-0.012	-0.085	0.158	0.18
44.504	-51.567	9.753	44.508	-51.537	9.726	-0.004	-0.03	0.027	0.04
44.028	-54.716	4.897	44.051	-54.562	4.834	-0.022	-0.154	0.063	0.168
53.739	-25.49	4.84	53.762	-25.458	4.856	-0.023	-0.032	-0.016	-0.042
52.402	-28.167	9.797	52.379	-28.208	9.755	0.023	0.041	0.042	0.063
50.233	-32.132	13.458	50.197	-32.197	13.32	0.036	0.065	0.138	0.157
47.578	-36.999	15.229	47.571	-37.011	15.138	0.007	0.012	0.091	0.092
32.205	-49.813	0.666	32.331	-49.718	0.432	-0.126	-0.095	0.234	0.283
36.651	-54.157	0.475	36.704	-54.076	0.292	-0.052	-0.081	0.183	0.207
45.261	-56.563	0.8	45.271	-56.396	0.604	-0.01	-0.167	0.196	0.258
54.766	-54.331	1.045	54.628	-54.083	0.77	0.139	-0.248	0.275	0.396
61.336	-48.046	1.263	60.944	-47.814	0.864	0.392	-0.233	0.398	0.606
63.416	-39.441	1.036	63.273	-39.438	0.919	0.143	-0.003	0.118	0.185
5.58	29.893	-10.34	5.58	29.465	-10.468	0	0.428	0.128	0.447
2.212	29.85	-10.353	2.212	29.465	-10.468	0	0.385	0.116	0.402
2.215	26.713	0.172	2.215	26.309	0.051	0	0.404	0.121	0.421
-1.153	29.895	-10.34	-1.153	29.465	-10.469	0	0.429	0.129	0.448
5.588	20.385	-12.723	5.588	20.016	-12.612	0	0.369	-0.111	-0.386
2.217	23.487	-2.186	2.217	23.172	-2.091	0	0.314	-0.094	-0.328
2.222	20.225	-12.676	2.222	20.016	-12.613	0	0.21	-0.063	-0.219
-1.144	20.327	-12.706	-1.144	20.016	-12.613	0	0.311	-0.093	-0.325
7.713	27.525	-10.645	8.026	27.525	-10.519	-0.313	0	-0.125	-0.337
7.814	24.999	-10.604	8.026	24.999	-10.519	-0.212	0	-0.085	-0.228
3.629	24.995	-0.074	3.818	24.995	0.001	-0.188	0	-0.075	-0.203
7.705	22.474	-10.65	8.027	22.474	-10.521	-0.322	0	-0.129	-0.347
-4.519	27.52	-12.592	-4.576	27.52	-12.57	0.057	0	-0.023	-0.061
-0.236	24.992	-2.101	-0.368	24.992	-2.048	0.132	0	-0.053	-0.142
-4.667	24.994	-12.533	-4.576	24.994	-12.569	-0.091	0	0.036	0.098
-4.531	22.469	-12.587	-4.576	22.469	-12.569	0.045	0	-0.018	-0.049
-9.179	5.022	-2.081	-9.23	5.05	-2.081	0.051	-0.028	0	0.058
-9.342	5.104	9.704	-9.233	5.044	9.704	-0.11	0.06	0	-0.125
-0.564	10.339	9.707	-0.573	10.505	9.707	0.009	-0.166	0	0.166
-0.554	10.261	-2.078	-0.567	10.506	-2.078	0.013	-0.244	0	0.245
8.669	6.158	-2.074	8.577	6.092	-2.074	0.092	0.065	0	-0.113
8.722	6.197	9.711	8.576	6.094	9.711	0.146	0.104	0	-0.179
10.202	-3.36	9.707	9.993	-3.291	9.707	0.209	-0.069	0	-0.22
10.327	-3.396	0.87	9.994	-3.287	0.87	0.332	-0.109	0	-0.35
0.098	-10.355	0.866	0.099	-10.52	0.866	-0.002	0.165	0	0.165

0.095	-10.559	9.704		0.094	-10.52	9.704		0	-0.038	0		-0.038
-10.09	-3.389	9.702		-9.973	-3.35	9.702		-0.116	-0.039	0		-0.123
-9.954	-3.349	0.863		-9.972	-3.355	0.863		0.018	0.006	0		0.019
10.689	-10.126	3.813		10.693	-10.13	3.813		-0.004	0.003	0		-0.005
-11.017	-9.545	3.806		-11.132	-9.645	3.806		0.115	0.1	0		-0.153
-14.503	1.856	0.864		-14.61	1.87	0.864		0.107	-0.014	0		-0.107
-8.216	12.01	3.814		-8.316	12.157	3.814		0.1	-0.147	0		-0.178
3.524	14.267	0.873		3.532	14.3	0.873		-0.008	-0.032	0		-0.033
12.736	6.802	3.819		12.992	6.939	3.819		-0.256	-0.137	0		-0.29
1.953	2.109	-16.501		1.953	2.109	-16.833		0	0	0.333		0.333
-3.722	3.779	-16.771		-3.722	3.779	-16.833		0	0	0.062		0.062
-3.8	-4.154	-16.758		-3.8	-4.154	-16.833		0	0	0.075		0.075
3.772	-4.007	-16.804		3.772	-4.007	-16.833		0	0	0.029		0.029
0.446	-0.506	-18.782		1.08	-1.084	-18.782		-0.634	0.578	0		0.858
-9.305	-8.588	12.757		-9.305	-8.588	12.625		0	0	0.132		0.132
-11.947	3.469	12.719		-11.947	3.469	12.625		0	0	0.094		0.094
-0.877	11.954	12.739		-0.877	11.954	12.625		0	0	0.114		0.114
11.286	4.888	12.582		11.286	4.888	12.625		0	0	-0.043		-0.043
10.638	-7.052	12.651		10.638	-7.052	12.625		0	0	0.026		0.026
0.501	-12.862	12.643		0.501	-12.862	12.625		0	0	0.018		0.018
-0.384	-14.827	6.894		-0.381	-14.724	6.894		-0.003	-0.102	0		0.102
6.953	-46.814	6.747		6.972	-46.814	6.747		-0.019	0	0		-0.019
7.093	-36.808	6.751		6.972	-36.808	6.751		0.121	0	0		0.121
6.857	-26.801	6.754		6.972	-26.801	6.754		-0.115	0	0		-0.115
6.977	-16.794	6.757		6.972	-16.794	6.757		0.005	0	0		0.005
4.587	-17.758	6.755		4.447	-17.758	6.755		0.14	0	0		-0.14
4.693	-27.482	6.753		4.447	-27.482	6.753		0.246	0	0		-0.246
4.684	-37.203	6.749		4.447	-37.203	6.749		0.237	0	0		-0.237
4.589	-46.927	6.747		4.447	-46.927	6.747		0.142	0	0		-0.142
-4.461	-46.941	9.69		-3.97	-46.941	9.69		-0.491	0	0		-0.491
-4.426	-37.255	9.693		-3.97	-37.255	9.693		-0.457	0	0		-0.457
-4.449	-27.571	9.697		-3.97	-27.571	9.697		-0.479	0	0		-0.479
-4.219	-17.887	9.698		-3.97	-17.887	9.698		-0.249	0	0		-0.249
-8.091	-16.148	3.806		-8.178	-16.148	3.806		0.087	0	0		-0.087
-8.219	-26.349	3.803		-8.178	-26.349	3.803		-0.041	0	0		0.041
-8.481	-36.55	3.801		-8.178	-36.55	3.801		-0.303	0	0		0.303
-8.524	-46.752	3.797		-8.178	-46.752	3.797		-0.346	0	0		0.346
-5.981	-50.53	7.193		-5.981	-50.5	7.193		0	-0.03	0		0.03
5.768	-50.38	10.43		5.768	-50.5	10.43		0	0.12	0		-0.12
5.762	-46.588	12.767		5.762	-46.588	12.625		0	0	0.142		0.142
5.781	-37.543	12.827		5.781	-37.543	12.625		0	0	0.202		0.202

5.686	-28.5	12.736	5.686	-28.5	12.625	0	0	0.111	0.111
5.912	-17.532	12.704	5.912	-17.532	12.625	0	0	0.079	0.079
-6.078	-16.979	13.462	-6.078	-16.979	12.625	0	0	0.837	0.837
-6.196	-27.382	12.724	-6.196	-27.382	12.625	0	0	0.099	0.099
-6.216	-36.2	12.686	-6.216	-36.2	12.625	0	0	0.061	0.061
-5.754	-47.953	12.774	-5.754	-47.953	12.625	0	0	0.149	0.149
63.096	-85.808	-0.011	63.096	-85.808	0	0	0	-0.011	-0.011
51.667	-86.179	-0.064	51.667	-86.179	0	0	0	-0.064	-0.064
30.922	-85.707	-0.026	30.922	-85.707	0	0	0	-0.026	-0.026
26.936	-77.989	0.122	26.936	-77.989	0	0	0	0.122	0.122
40.12	-79.711	-0.177	40.12	-79.711	0	0	0	-0.177	-0.177
56.556	-76.317	-0.1	56.556	-76.317	0	0	0	-0.1	-0.1
61.202	-67.017	-0.125	61.202	-67.017	0	0	0	-0.125	-0.125
47.211	-70.273	-0.309	47.211	-70.273	0	0	0	-0.309	-0.309
37.691	-65.879	-0.214	37.691	-65.879	0	0	0	-0.214	-0.214
24.042	-65.555	0.054	24.042	-65.555	0	0	0	0.054	0.054
20.077	-53.454	0.045	20.077	-53.454	0	0	0	0.045	0.045
15.307	-46.327	-0.07	15.307	-46.327	0	0	0	-0.07	-0.07
23.716	-45.581	-0.139	23.716	-45.581	0	0	0	-0.139	-0.139
14.953	-35.394	-0.269	14.953	-35.394	0	0	0	-0.269	-0.269
15.814	-25.434	-0.363	15.814	-25.434	0	0	0	-0.363	-0.363
25.726	-28.368	-0.193	25.726	-28.368	0	0	0	-0.193	-0.193
33.711	-23.372	-0.207	33.711	-23.372	0	0	0	-0.207	-0.207
61.801	-24.51	-0.033	61.801	-24.51	0	0	0	-0.033	-0.033
68.184	-35.029	-0.01	68.184	-35.029	0	0	0	-0.01	-0.01
65.385	-55.001	0.155	65.385	-55.001	0	0	0	0.155	0.155
69.031	-6.579	-0.078	69.031	-6.579	0	0	0	-0.078	-0.078
66.196	18.418	-0.058	66.196	18.418	0	0	0	-0.058	-0.058
52.29	18.992	-0.441	52.29	18.992	0	0	0	-0.441	-0.441
38.413	18.738	-0.561	38.413	18.738	0	0	0	-0.561	-0.561
25.059	19.058	-0.365	25.059	19.058	0	0	0	-0.365	-0.365
27.159	28.518	-0.238	27.159	28.518	0	0	0	-0.238	-0.238
34.3	26.858	-0.168	34.3	26.858	0	0	0	-0.168	-0.168
46.042	25.926	-0.177	46.042	25.926	0	0	0	-0.177	-0.177
45.724	34.466	0.135	45.724	34.466	0	0	0	0.135	0.135
29.749	39.375	-0.046	29.749	39.375	0	0	0	-0.046	-0.046
17.391	42.215	-0.326	17.391	42.215	0	0	0	-0.326	-0.326
7.153	39.342	-0.361	7.153	39.342	0	0	0	-0.361	-0.361
10.319	49.393	-0.175	10.319	49.393	0	0	0	-0.175	-0.175
23.006	52.36	-0.123	23.006	52.36	0	0	0	-0.123	-0.123
43.305	55.616	0.052	43.305	55.616	0	0	0	0.052	0.052

66.497	54.291	0.039	66.497	54.291	0	0	0	0.039	0.039
67.09	38.314	0.257	67.09	38.314	0	0	0	0.257	0.257
-12.134	40.809	-0.331	-12.134	40.809	0	0	0	-0.331	-0.331
-22.702	17.511	0	-22.702	17.511	0	0	0	0	0
-24.009	30.703	0.017	-24.009	30.703	0	0	0	0.017	0.017
-31.185	26.015	0.051	-31.185	26.015	0	0	0	0.051	0.051
-42.916	26.672	-0.048	-42.916	26.672	0	0	0	-0.048	-0.048
-50.409	30.524	-0.022	-50.409	30.524	0	0	0	-0.022	-0.022
-40.369	46.077	0.193	-40.369	46.077	0	0	0	0.193	0.193
-47.494	54.633	-0.097	-47.494	54.633	0	0	0	-0.097	-0.097
-75.506	53.841	-0.04	-75.506	53.841	0	0	0	-0.04	-0.04
-75.716	37.558	-0.013	-75.716	37.558	0	0	0	-0.013	-0.013
-74.497	19.4	-0.018	-74.497	19.4	0	0	0	-0.018	-0.018
-57.021	25.308	-0.02	-57.021	25.308	0	0	0	-0.02	-0.02
-66.055	11.998	0.011	-66.055	11.998	0	0	0	0.011	0.011
-68.565	-1.062	0.071	-68.565	-1.062	0	0	0	0.071	0.071
-76.915	-10.758	0.046	-76.915	-10.758	0	0	0	0.046	0.046
-76.773	-29.233	-0.005	-76.773	-29.233	0	0	0	-0.005	-0.005
-62.507	-24.827	0.03	-62.507	-24.827	0	0	0	0.03	0.03
-49.823	-21.861	-0.041	-49.823	-21.861	0	0	0	-0.041	-0.041
-35.492	-26.557	-0.016	-35.492	-26.557	0	0	0	-0.016	-0.016
-22.74	-18.071	-0.059	-22.74	-18.071	0	0	0	-0.059	-0.059
-27.746	-37.017	0.001	-27.746	-37.017	0	0	0	0.001	0.001
-13.613	-51.096	-0.209	-13.613	-51.096	0	0	0	-0.209	-0.209
-5.111	-60.148	-0.337	-5.111	-60.148	0	0	0	-0.337	-0.337
-6.344	-70.95	-0.354	-6.344	-70.95	0	0	0	-0.354	-0.354
-7.683	-86.169	-0.232	-7.683	-86.169	0	0	0	-0.232	-0.232
-27.11	-90.77	-0.245	-27.11	-90.77	0	0	0	-0.245	-0.245
-40.803	-88.532	-0.163	-40.803	-88.532	0	0	0	-0.163	-0.163
-53.561	-82.124	-0.026	-53.561	-82.124	0	0	0	-0.026	-0.026
-62.768	-90.75	-0.085	-62.768	-90.75	0	0	0	-0.085	-0.085
-77.096	-86.055	-0.137	-77.096	-86.055	0	0	0	-0.137	-0.137
-75.447	-64.48	-0.045	-75.447	-64.48	0	0	0	-0.045	-0.045
-71.845	-44.211	0.042	-71.845	-44.211	0	0	0	0.042	0.042
-65.687	-56.112	-0.027	-65.687	-56.112	0	0	0	-0.027	-0.027
-62.057	-65.902	-0.017	-62.057	-65.902	0	0	0	-0.017	-0.017
-50.343	-58.837	-0.067	-50.343	-58.837	0	0	0	-0.067	-0.067
-50.093	-72.893	-0.07	-50.093	-72.893	0	0	0	-0.07	-0.07
-13.974	-37.949	-16.718	-13.974	-37.949	-16.833	0	0	0.115	0.115
-14.374	-16.552	-16.746	-14.374	-16.552	-16.833	0	0	0.087	0.087
-13.567	16.125	-16.667	-13.567	16.125	-16.833	0	0	0.166	0.166

-13.403	29.333	-16.719		-13.403	29.333	-16.833		0	0	0.115		0.115
14.656	31.603	-16.816		14.656	31.603	-16.833		0	0	0.017		0.017
15.527	23.897	-16.761		15.527	23.897	-16.833		0	0	0.072		0.072
15.794	12.207	-16.788		15.794	12.207	-16.833		0	0	0.045		0.045
59.983	4.304	-16.478		59.983	4.304	-16.833		0	0	0.355		0.355
58.428	-9.968	-16.601		58.428	-9.968	-16.833		0	0	0.232		0.232
48.937	-15.264	-16.759		48.937	-15.264	-16.833		0	0	0.074		0.074
36.527	-9.672	-16.797		36.527	-9.672	-16.833		0	0	0.036		0.036
30.76	-17.698	-16.767		30.76	-17.698	-16.833		0	0	0.067		0.067
13.3	-15.185	-16.652		13.3	-15.185	-16.833		0	0	0.181		0.181
19.582	2.798	-4.794		19.582	2.798	-4.208		0	0	-0.586		-0.586
28.967	7.208	-4.857		28.967	7.208	-4.208		0	0	-0.649		-0.649
34.493	2.952	-4.795		34.493	2.952	-4.208		0	0	-0.587		-0.587
41.246	7.335	-4.822		41.246	7.335	-4.208		0	0	-0.613		-0.613
46.474	2.151	-4.586		46.474	2.151	-4.208		0	0	-0.378		-0.378
52.069	8.372	-4.577		52.069	8.372	-4.208		0	0	-0.369		-0.369
50.902	-3.225	-0.147		50.902	-3.225	0		0	0	-0.147		-0.147
40.378	-3.846	0.119		40.378	-4.03	0		0	0.184	0.119		0.219
28.686	-2.024	0.066		28.686	-1.926	0		0	-0.098	0.066		0.118
16.999	-2.035	-0.518		16.999	-2.035	0		0	0	-0.518		-0.518
18.62	-9.362	1.562		18.62	-9.362	1.683		0	0	-0.122		-0.122
24.777	-6.525	1.503		24.777	-6.525	1.683		0	0	-0.18		-0.18
25.892	-14.833	1.631		25.892	-14.833	1.683		0	0	-0.052		-0.052
18.854	-12.038	-4.081		18.854	-12.447	-4.081		0	0.409	0		-0.409
24.879	-16.8	0.303		24.59	-16.655	0.303		0.289	-0.144	0		0.323
33.058	-3.82	-4.139		33.058	-4.03	-4.139		0	0.21	0		-0.21
40.083	-3.721	-3.384		40.083	-4.03	-3.384		0	0.309	0		-0.309
52.704	-3.952	-4.655		52.704	-4.03	-4.655		0	0.078	0		-0.078
55.464	0.021	-8.927		55.257	0.087	-8.927		0.207	-0.066	0		0.218
56.68	7.891	-9.67		56.527	7.891	-9.67		0.153	0	0		0.153
59.531	12.424	-0.735		59.531	12.37	-0.62		0	0.054	-0.115		-0.127
49.315	13.399	-1.742		49.315	13.182	-1.366		0	0.217	-0.375		-0.434
39.478	12.763	-1.67		39.478	12.396	-1.303		0	0.367	-0.367		-0.518

### 3D-Tol Data from CMM for SLS Titanium Casting

MEAS X	MEAS Y	MEAS Z		CAD X	CAD Y	CAD Z		DIF X	DIF Y	DIF Z		TOT DIF
53.692	58.937	-5.548		53.692	58.917	-5.548		0	0.021	0		0.021
37.147	58.969	-5.549		37.147	58.917	-5.549		0	0.052	0		0.052
20.602	58.98	-5.551		20.602	58.917	-5.551		0	0.064	0		0.064
4.058	58.96	-5.554		4.058	58.917	-5.554		0	0.043	0		0.043

-12.487	58.986	-5.557	-12.487	58.917	-5.557	0	0.069	0	0.069
-29.031	58.976	-5.559	-29.031	58.917	-5.559	0	0.059	0	0.059
-45.576	58.952	-5.562	-45.576	58.917	-5.562	0	0.035	0	0.035
-62.121	58.974	-5.564	-62.121	58.917	-5.564	0	0.057	0	0.057
-80.209	41.071	-5.578	-79.958	41.071	-5.578	-0.25	0	0	0.25
-80.119	24.528	-5.586	-79.958	24.528	-5.586	-0.161	0	0	0.161
-80.063	7.983	-5.593	-79.958	7.983	-5.593	-0.104	0	0	0.104
-80.011	-8.564	-5.601	-79.958	-8.564	-5.601	-0.052	0	0	0.052
-79.988	-25.108	-5.609	-79.958	-25.108	-5.609	-0.03	0	0	0.03
-79.98	-41.653	-5.616	-79.958	-41.653	-5.616	-0.021	0	0	0.021
-80.003	-58.195	-5.623	-79.958	-58.195	-5.623	-0.045	0	0	0.045
-79.978	-74.742	-5.631	-79.958	-74.742	-5.631	-0.02	0	0	0.02
-62.119	-92.801	-5.639	-62.119	-92.583	-5.639	0	-0.217	0	0.217
-45.574	-92.754	-5.636	-45.574	-92.583	-5.636	0	-0.171	0	0.171
-29.029	-92.759	-5.634	-29.029	-92.583	-5.634	0	-0.176	0	0.176
-12.484	-92.753	-5.631	-12.484	-92.583	-5.631	0	-0.169	0	0.169
4.06	-92.756	-5.629	4.06	-92.583	-5.629	0	-0.173	0	0.173
20.606	-92.757	-5.627	20.606	-92.583	-5.627	0	-0.174	0	0.174
37.151	-92.747	-5.623	37.151	-92.583	-5.623	0	-0.164	0	0.164
53.696	-92.801	-5.62	53.696	-92.583	-5.62	0	-0.217	0	0.217
71.873	-74.739	-5.614	71.542	-74.739	-5.614	0.331	0	0	0.331
71.865	-58.196	-5.601	71.542	-58.196	-5.601	0.323	0	0	0.323
71.861	-41.652	-5.593	71.542	-41.652	-5.593	0.319	0	0	0.319
71.817	-25.105	-5.585	71.542	-25.105	-5.585	0.275	0	0	0.275
71.917	-8.562	-5.577	71.542	-8.562	-5.577	0.375	0	0	0.375
71.907	7.984	-5.569	71.542	7.984	-5.569	0.365	0	0	0.365
71.912	24.527	-5.562	71.542	24.527	-5.562	0.371	0	0	0.371
71.978	41.072	-5.555	71.542	41.072	-5.555	0.436	0	0	0.436
-69.866	43.757	8.456	-69.866	43.757	8.417	0	0	0.04	0.04
-64.815	43.756	8.476	-64.815	43.756	8.417	0	0	0.059	0.059
-64.815	48.807	8.475	-64.815	48.807	8.417	0	0	0.058	0.058
-69.867	48.807	8.533	-69.867	48.807	8.417	0	0	0.116	0.116
-67.735	46.402	8.519	-67.735	46.402	8.417	0	0	0.103	0.103
-71.926	43.759	7.05	-71.542	43.759	7.05	-0.385	0	0	0.385
-71.894	48.809	7.056	-71.542	48.809	7.056	-0.352	0	0	0.352
-69.867	50.629	7.054	-69.867	50.5	7.054	0	0.129	0	0.129
-64.814	50.708	7.055	-64.814	50.5	7.055	0	0.208	0	0.208
-64.817	42.174	7.048	-64.817	42.083	7.048	0	0.09	0	-0.09
-69.869	42.175	7.049	-69.869	42.083	7.049	0	0.092	0	-0.092
-63.335	48.809	7.052	-63.125	48.809	7.052	-0.21	0	0	-0.21
-63.304	43.758	7.049	-63.125	43.758	7.049	-0.179	0	0	-0.179

-64.815	-14.315	4.186	-64.815	-14.315	4.208	0	0	-0.023	-0.023
-69.865	-14.315	4.174	-69.865	-14.315	4.208	0	0	-0.035	-0.035
-69.865	-19.366	4.19	-69.865	-19.366	4.208	0	0	-0.018	-0.018
-64.813	-19.366	4.137	-64.813	-19.366	4.208	0	0	-0.071	-0.071
-67.985	-16.742	4.168	-67.985	-16.742	4.208	0	0	-0.041	-0.041
-69.864	-12.638	3.658	-69.864	-12.625	3.658	0	-0.013	0	-0.013
-64.813	-12.596	3.659	-64.813	-12.625	3.659	0	0.029	0	0.029
-63.142	-14.315	4.22	-63.125	-14.315	4.208	-0.017	0	0.012	-0.021
-63.155	-19.366	4.23	-63.125	-19.366	4.208	-0.03	0	0.022	-0.037
-64.816	-21.076	3.652	-64.816	-21.042	3.652	0	-0.035	0	0.035
-69.866	-21.08	3.653	-69.866	-21.042	3.653	0	-0.038	0	0.038
-71.782	-19.364	3.654	-71.542	-19.364	3.654	-0.24	0	0	0.24
-71.737	-14.313	3.658	-71.542	-14.313	3.658	-0.196	0	0	0.196
-64.815	-77.443	8.614	-64.815	-77.443	8.417	0	0	0.197	0.197
-69.864	-77.443	8.556	-69.864	-77.443	8.417	0	0	0.139	0.139
-69.865	-82.493	8.581	-69.865	-82.493	8.417	0	0	0.165	0.165
-64.813	-82.494	8.516	-64.813	-82.494	8.417	0	0	0.099	0.099
-69.864	-75.893	6.995	-69.864	-75.75	6.995	0	-0.143	0	-0.143
-64.812	-75.908	6.995	-64.812	-75.75	6.995	0	-0.158	0	-0.158
-63.277	-77.441	6.992	-63.125	-77.441	6.992	-0.152	0	0	-0.152
-63.249	-82.492	6.99	-63.125	-82.492	6.99	-0.124	0	0	-0.124
-64.816	-84.322	6.99	-64.816	-84.167	6.99	0	-0.155	0	0.155
-69.865	-84.324	6.991	-69.865	-84.167	6.991	0	-0.158	0	0.158
-71.726	-82.49	6.991	-71.542	-82.49	6.991	-0.184	0	0	0.184
-71.73	-77.438	6.995	-71.542	-77.438	6.995	-0.188	0	0	0.188
-2.533	43.76	4.079	-2.533	43.76	4.208	0	0	-0.129	-0.129
2.518	43.76	4.117	2.518	43.76	4.208	0	0	-0.092	-0.092
2.518	48.811	4.132	2.518	48.811	4.208	0	0	-0.076	-0.076
-2.534	48.811	4.118	-2.534	48.811	4.208	0	0	-0.09	-0.09
-0.691	46.794	4.329	-0.691	46.794	4.208	0	0	0.121	0.121
-4.286	43.763	2.432	-4.208	43.763	2.432	-0.077	0	0	0.077
-4.249	48.813	2.439	-4.208	48.813	2.439	-0.04	0	0	0.04
2.516	42.134	2.43	2.516	42.083	2.43	0	0.051	0	-0.051
-2.534	42.144	2.431	-2.534	42.083	2.431	0	0.06	0	-0.06
4.217	48.812	2.432	4.208	48.812	2.432	0.009	0	0	0.009
4.22	43.762	2.431	4.208	43.762	2.431	0.012	0	0	0.012
-2.533	50.602	2.435	-2.533	50.5	2.435	0	0.102	0	0.102
2.52	50.582	2.436	2.52	50.5	2.436	0	0.082	0	0.082
-64.87	36.291	-0.951	-64.789	36.211	-0.951	-0.081	0.081	0	-0.114
-54.13	46.98	-0.944	-54.075	46.925	-0.944	-0.055	0.055	0	-0.078
-46.931	46.932	-0.941	-46.931	46.931	-0.941	0.001	0.001	0	-0.001

-36.253	36.183	-0.943	-36.218	36.218	-0.943	-0.035	-0.035	0	0.049
-41.005	29.049	-0.947	-40.978	29.075	-0.947	-0.027	-0.027	0	-0.038
-48.167	36.173	-0.944	-48.121	36.218	-0.944	-0.046	-0.046	0	-0.064
-35.787	29.609	-1.327	-35.734	29.557	-1.327	-0.052	0.052	0	0.074
-54.136	35.079	-0.947	-54.077	35.02	-0.947	-0.059	0.059	0	0.084
-58.928	30.347	-0.947	-58.839	30.258	-0.947	-0.089	0.089	0	0.126
-65.474	29.534	-0.854	-65.359	29.65	-0.854	-0.116	-0.116	0	-0.163
-61.401	33.557	-4.433	-61.401	33.557	-4.208	0	0	-0.224	-0.224
-56.832	38.312	-4.372	-56.832	38.312	-4.208	0	0	-0.164	-0.164
-50.337	43.715	-4.395	-50.337	43.715	-4.208	0	0	-0.187	-0.187
-44.776	38.668	-4.422	-44.776	38.668	-4.208	0	0	-0.214	-0.214
-40.102	33.859	-4.365	-40.102	33.859	-4.208	0	0	-0.157	-0.157
49.649	42.151	6.225	49.649	42.083	6.225	0	0.068	0	-0.068
42.915	42.138	6.225	42.915	42.083	6.225	0	0.055	0	-0.055
54.852	30.294	6.222	54.708	30.294	6.222	0.144	0	0	-0.144
54.844	37.03	6.226	54.708	37.03	6.226	0.135	0	0	-0.135
58.789	25.263	5.725	58.789	25.25	5.725	0	0.013	0	-0.013
63.269	30.295	6.219	63.125	30.295	6.219	0.144	0	0	0.144
63.263	37.87	6.226	63.125	37.87	6.226	0.138	0	0	0.138
63.285	45.445	6.229	63.125	45.445	6.229	0.16	0	0	0.16
58.066	50.486	6.232	58.066	50.5	6.232	0	-0.014	0	-0.014
50.493	50.528	6.233	50.493	50.5	6.233	0	0.028	0	0.028
42.917	50.521	6.232	42.917	50.5	6.232	0	0.021	0	0.021
37.911	46.238	5.509	37.875	46.238	5.509	0.036	0	0	-0.036
43.166	46.403	8.417	43.166	46.403	8.417	0	0	0.001	0.001
50.4	46.114	8.421	50.4	46.114	8.417	0	0	0.005	0.005
58.371	45.782	8.496	58.371	45.782	8.417	0	0	0.08	0.08
59.111	37.518	8.424	59.111	37.518	8.417	0	0	0.008	0.008
58.987	30.673	8.421	58.987	30.673	8.417	0	0	0.004	0.004
-30.914	49.103	17.147	-30.914	49.006	17.203	0	0.097	-0.056	-0.112
-30.912	46.192	12.123	-30.912	46.103	12.175	0	0.089	-0.052	-0.103
-30.911	43.257	7.114	-30.911	43.2	7.147	0	0.057	-0.033	-0.066
-30.911	40.358	2.091	-30.911	40.3	2.124	0	0.058	-0.033	-0.067
-27.121	40.38	2.077	-27.121	40.3	2.123	0	0.08	-0.046	-0.092
-27.122	43.293	7.095	-27.122	43.201	7.148	0	0.092	-0.053	-0.106
-27.124	46.195	12.124	-27.124	46.104	12.177	0	0.091	-0.052	-0.105
-27.124	49.111	17.143	-27.124	49.006	17.204	0	0.105	-0.061	-0.121
-23.337	49.138	17.127	-23.337	49.006	17.203	0	0.132	-0.076	-0.153
-23.338	46.18	12.132	-23.338	46.104	12.176	0	0.076	-0.044	-0.088
-23.336	43.329	7.075	-23.336	43.201	7.148	0	0.128	-0.074	-0.148
-23.335	40.35	2.096	-23.335	40.301	2.124	0	0.05	-0.029	-0.057

-17.023	45.544	2.172	-17.023	45.491	2.186	0	0.053	-0.014	-0.055
-17.024	47.575	9.71	-17.024	47.511	9.727	0	0.064	-0.017	-0.066
-17.025	49.631	17.239	-17.025	49.532	17.266	0	0.099	-0.027	-0.103
-11.975	49.644	17.237	-11.975	49.532	17.267	0	0.112	-0.03	-0.116
-11.974	47.59	9.705	-11.974	47.511	9.726	0	0.079	-0.021	-0.081
-11.973	45.552	2.173	-11.973	45.492	2.19	0	0.061	-0.016	-0.063
-8.222	49.61	7.853	-8.178	49.61	7.853	-0.044	0	0	-0.044
-30.913	51.006	15.42	-30.913	50.882	15.387	0	0.124	0.033	0.128
-30.913	52.482	9.754	-30.913	52.398	9.731	0	0.084	0.022	0.087
-30.911	53.998	4.101	-30.911	53.913	4.078	0	0.086	0.023	0.089
-24.176	53.963	4.093	-24.176	53.912	4.079	0	0.051	0.014	0.053
-24.177	52.446	9.746	-24.177	52.397	9.733	0	0.049	0.013	0.051
-24.178	51.01	15.421	-24.178	50.882	15.387	0	0.128	0.034	0.133
-17.444	50.999	15.419	-17.444	50.882	15.388	0	0.117	0.031	0.121
-17.445	52.484	9.758	-17.445	52.397	9.734	0	0.087	0.023	0.09
-17.444	53.976	4.096	-17.444	53.912	4.079	0	0.063	0.017	0.066
-10.709	53.97	4.095	-10.709	53.912	4.08	0	0.058	0.016	0.06
-10.71	52.487	9.759	-10.71	52.397	9.735	0	0.091	0.024	0.094
-10.711	51.043	15.431	-10.711	50.882	15.388	0	0.161	0.043	0.166
-33.604	48.951	9.998	-33.428	48.951	9.998	-0.176	0	0	0.176
5.17	-63.136	19.09	5.119	-63.136	19.104	0.052	0	-0.014	-0.053
3.284	-63.133	12.02	3.225	-63.133	12.036	0.059	0	-0.016	-0.061
1.376	-63.128	4.956	1.331	-63.128	4.968	0.045	0	-0.012	-0.046
1.36	-69.864	4.959	1.331	-69.864	4.966	0.03	0	-0.008	-0.031
3.295	-69.867	12.014	3.224	-69.867	12.033	0.071	0	-0.019	-0.073
5.149	-69.871	19.093	5.118	-69.871	19.101	0.031	0	-0.008	-0.032
5.139	-76.603	19.093	5.117	-76.603	19.099	0.021	0	-0.006	-0.022
3.301	-76.599	12.009	3.223	-76.599	12.03	0.078	0	-0.021	-0.081
1.358	-76.596	4.956	1.33	-76.596	4.963	0.028	0	-0.007	-0.029
1.319	-83.331	4.963	1.329	-83.331	4.961	-0.01	0	0.003	0.01
3.274	-83.334	12.013	3.223	-83.334	12.027	0.052	0	-0.014	-0.054
5.12	-83.337	19.095	5.117	-83.337	19.095	0.003	0	-0.001	-0.003
7.453	-85.923	10.629	7.453	-85.85	10.629	0	-0.073	0	0.073
7.54	-83.339	21.401	7.554	-83.339	21.408	-0.013	0	-0.008	-0.016
13.049	-83.336	12.016	12.995	-83.336	11.984	0.054	0	0.031	0.063
18.463	-83.33	2.577	18.435	-83.33	2.561	0.028	0	0.016	0.032
18.469	-75.754	2.584	18.434	-75.754	2.564	0.035	0	0.02	0.04
12.987	-75.759	11.985	12.993	-75.759	11.988	-0.006	0	-0.003	-0.007
7.502	-75.763	21.382	7.552	-75.763	21.411	-0.051	0	-0.029	-0.059
6.856	-69.451	21.458	6.874	-69.451	21.463	-0.018	0	-0.005	-0.019
9.379	-69.447	12.033	9.399	-69.447	12.038	-0.02	0	-0.005	-0.021

11.891	-69.442	2.605	11.924	-69.442	2.615	-0.034	0	-0.009	-0.035
11.897	-64.394	2.611	11.924	-64.394	2.618	-0.026	0	-0.007	-0.027
9.397	-64.397	12.04	9.399	-64.397	12.04	-0.002	0	-0.001	-0.002
6.847	-64.404	21.459	6.873	-64.404	21.466	-0.026	0	-0.007	-0.027
6.437	-60.587	11.392	6.437	-60.6	11.392	0	0.013	0	0.013
-30.545	-50.332	-5.192	-30.548	-50.284	-5.239	0.003	-0.048	0.046	0.067
-30.251	-54.914	-7.862	-30.249	-54.958	-7.775	-0.003	0.044	-0.087	-0.098
-30.022	-58.549	-11.338	-30.028	-58.451	-11.391	0.006	-0.098	0.053	0.111
-29.837	-61.399	-15.705	-29.839	-61.377	-15.733	0.001	-0.022	0.028	0.036
-33.897	-63.354	-15.728	-33.901	-63.351	-15.734	0.003	-0.003	0.006	0.008
-35.984	-61.486	-11.317	-36.087	-61.394	-11.392	0.103	-0.092	0.074	0.157
-38.727	-59.035	-7.86	-38.695	-59.064	-7.776	-0.032	0.029	-0.084	-0.095
-42.17	-55.951	-5.218	-42.186	-55.937	-5.239	0.016	-0.014	0.021	0.03
-46.538	-68.123	-5.264	-46.518	-68.122	-5.245	-0.02	-0.001	-0.019	-0.027
-41.891	-67.908	-7.87	-41.843	-67.905	-7.776	-0.048	-0.002	-0.094	-0.106
-38.301	-67.739	-11.369	-38.348	-67.742	-11.394	0.047	0.002	0.025	0.054
-35.426	-67.605	-15.752	-35.414	-67.605	-15.738	-0.012	-0.001	-0.015	-0.019
-33.555	-71.744	-15.82	-33.513	-71.699	-15.741	-0.042	-0.045	-0.079	-0.1
-35.553	-73.902	-11.431	-35.51	-73.855	-11.397	-0.043	-0.046	-0.034	-0.072
-37.939	-76.47	-7.918	-37.89	-76.417	-7.778	-0.049	-0.053	-0.141	-0.158
-41.115	-79.895	-5.315	-41.071	-79.848	-5.251	-0.044	-0.048	-0.064	-0.091
-29.682	-67.396	-17.123	-29.714	-67.405	-16.87	0.031	0.009	-0.253	-0.255
-26.585	-62.064	-15.791	-26.604	-62.1	-15.738	0.02	0.036	-0.052	-0.066
-25.205	-59.543	-11.38	-25.193	-59.522	-11.393	-0.011	-0.021	0.013	0.027
-23.484	-56.399	-7.892	-23.513	-56.451	-7.775	0.029	0.052	-0.117	-0.131
-21.239	-52.28	-5.322	-21.275	-52.347	-5.248	0.036	0.067	-0.074	-0.106
-12.969	-62.494	-5.364	-13.078	-62.526	-5.252	0.109	0.032	-0.112	-0.16
-17.464	-63.814	-7.984	-17.565	-63.844	-7.777	0.101	0.03	-0.207	-0.232
-20.844	-64.802	-11.438	-20.921	-64.825	-11.395	0.076	0.022	-0.043	-0.09
-23.626	-65.617	-15.899	-23.744	-65.652	-15.742	0.118	0.035	-0.157	-0.199
-24.094	-70.261	-15.952	-24.235	-70.184	-15.746	0.141	-0.077	-0.206	-0.261
-21.47	-71.699	-11.506	-21.65	-71.6	-11.395	0.18	-0.098	-0.11	-0.233
-18.492	-73.324	-7.976	-18.581	-73.275	-7.778	0.089	-0.049	-0.199	-0.223
-14.361	-75.587	-5.393	-14.483	-75.52	-5.256	0.122	-0.067	-0.137	-0.195
-24.617	-83.848	-5.401	-24.658	-83.709	-5.259	0.041	-0.139	-0.143	-0.204
-25.946	-79.321	-7.964	-25.973	-79.229	-7.777	0.027	-0.092	-0.187	-0.21
-26.901	-76.056	-11.503	-26.956	-75.87	-11.399	0.054	-0.186	-0.104	-0.22
-27.729	-73.236	-16.006	-27.786	-73.043	-15.748	0.057	-0.194	-0.258	-0.328
-32.377	-72.665	-15.908	-32.316	-72.554	-15.746	-0.061	-0.111	-0.162	-0.206
-33.783	-75.241	-11.461	-33.727	-75.139	-11.398	-0.056	-0.102	-0.062	-0.132
-35.439	-78.282	-7.93	-35.402	-78.213	-7.776	-0.037	-0.069	-0.154	-0.173

-37.692	-82.394	-5.349	-37.646	-82.31	-5.255	-0.046	-0.084	-0.094	-0.134
-25.411	-86.364	-0.504	-25.411	-86.365	-0.506	0	0.002	0.003	0.003
-12.893	-77.291	-0.721	-12.941	-77.262	-0.66	0.048	-0.029	-0.061	-0.083
-10.942	-61.736	-0.674	-10.979	-61.747	-0.63	0.037	0.011	-0.044	-0.058
-16.023	-53.447	-0.617	-16.024	-53.448	-0.616	0	0	0	-0.001
-25.785	-48.181	-0.507	-25.788	-48.196	-0.485	0.003	0.015	-0.022	-0.027
-47.496	-37.882	19.04	-47.317	-37.798	19.154	-0.178	-0.084	-0.114	-0.228
-44.216	-36.331	12.72	-44.023	-36.24	12.843	-0.193	-0.091	-0.123	-0.246
-40.865	-34.74	6.445	-40.731	-34.676	6.53	-0.134	-0.063	-0.085	-0.171
-40.075	-41.268	6.411	-39.878	-41.305	6.527	-0.197	0.037	-0.116	-0.232
-43.67	-40.594	12.713	-43.459	-40.634	12.837	-0.211	0.04	-0.124	-0.248
-47.266	-39.921	19.02	-47.043	-39.964	19.152	-0.224	0.043	-0.132	-0.263
-48.23	-41.721	19.026	-48.089	-41.872	19.145	-0.141	0.15	-0.119	-0.238
-45.678	-44.422	12.757	-45.587	-44.519	12.835	-0.092	0.098	-0.077	-0.155
-43.141	-47.104	6.471	-43.081	-47.167	6.521	-0.06	0.063	-0.05	-0.1
-49.124	-50.022	6.513	-49.123	-50.028	6.517	-0.001	0.006	-0.003	-0.007
-49.6	-46.319	12.775	-49.588	-46.413	12.829	-0.012	0.094	-0.054	-0.109
-50.07	-42.689	19.074	-50.056	-42.8	19.139	-0.014	0.111	-0.065	-0.129
-52.166	-42.351	19.109	-52.191	-42.396	19.139	0.025	0.046	-0.03	-0.06
-53.924	-45.568	12.808	-53.939	-45.595	12.826	0.015	0.027	-0.018	-0.035
-55.706	-48.826	6.535	-55.688	-48.793	6.513	-0.018	-0.033	0.022	0.043
-51.753	-39.9	22.956	-51.709	-39.879	22.928	-0.044	-0.021	0.028	0.056
-57.026	-42.398	12.855	-56.98	-42.376	12.826	-0.046	-0.022	0.029	0.059
-62.354	-44.92	2.795	-62.25	-44.87	2.728	-0.104	-0.05	0.067	0.134
-63.37	-36.888	2.785	-63.279	-36.905	2.731	-0.091	0.017	0.054	0.107
-57.626	-37.97	12.876	-57.548	-37.984	12.831	-0.077	0.014	0.045	0.091
-51.915	-39.045	22.99	-51.817	-39.062	22.933	-0.098	0.018	0.058	0.115
-51.472	-38.288	22.978	-51.425	-38.338	22.938	-0.048	0.05	0.04	0.079
-55.439	-34.085	12.846	-55.428	-34.097	12.837	-0.011	0.012	0.009	0.019
-59.419	-29.867	2.729	-59.429	-29.856	2.738	0.01	-0.011	-0.009	-0.018
-52.157	-26.51	2.689	-52.169	-26.414	2.745	0.012	-0.096	-0.056	-0.111
-51.416	-32.267	12.803	-51.425	-32.197	12.843	0.009	-0.07	-0.041	-0.082
-50.68	-37.959	22.955	-50.677	-37.98	22.943	-0.003	0.021	0.012	0.024
-49.9	-38.201	22.897	-49.861	-38.131	22.943	-0.038	-0.07	-0.046	-0.092
-47.144	-33.157	12.751	-47.066	-33.015	12.845	-0.078	-0.142	-0.094	-0.187
-44.347	-28.036	2.654	-44.271	-27.897	2.745	-0.076	-0.138	-0.091	-0.182
-46.514	4.155	25.046	-46.311	3.965	25.324	-0.202	0.19	-0.278	-0.393
-50.228	7.664	27.279	-50.284	7.716	27.538	0.056	-0.052	-0.26	-0.271
-53.7	10.94	22.138	-53.677	10.919	22.124	-0.022	0.021	0.014	0.034
-56.505	13.597	8.588	-56.414	13.512	8.565	-0.09	0.085	0.023	0.126
-61.901	-1.621	8.588	-61.716	-1.606	8.554	-0.185	-0.015	0.034	0.189

-58.019	-1.31	22.14	-57.961	-1.305	22.114	-0.059	-0.005	0.026	0.065
-53.258	-0.924	27.326	-53.32	-0.929	27.534	0.062	0.005	-0.208	-0.217
-48.112	-0.505	25.084	-47.866	-0.485	25.331	-0.246	-0.021	-0.247	-0.349
-45.7	-4.741	25.175	-45.604	-4.616	25.333	-0.095	-0.125	-0.158	-0.223
-48.888	-8.916	27.316	-48.927	-8.968	27.532	0.04	0.052	-0.217	-0.226
-51.659	-12.548	22.043	-51.749	-12.666	22.11	0.09	0.118	-0.067	-0.163
-54.068	-15.696	8.559	-54.038	-15.657	8.55	-0.03	-0.039	0.009	0.05
-38.466	-19.283	8.536	-38.451	-19.361	8.551	-0.015	0.078	-0.015	-0.081
-39.206	-15.369	21.98	-39.152	-15.66	22.112	-0.054	0.29	-0.133	-0.324
-40.033	-10.979	27.177	-40.014	-11.084	27.534	-0.02	0.105	-0.357	-0.373
-41.01	-5.794	25.239	-41.026	-5.705	25.329	0.016	-0.089	-0.091	-0.128
-40.342	19.574	8.565	-40.338	19.617	8.573	-0.004	-0.043	-0.008	-0.044
-40.687	15.726	22.075	-40.675	15.859	22.135	-0.012	-0.133	-0.06	-0.146
-41.098	11.137	27.315	-41.092	11.203	27.542	-0.006	-0.066	-0.228	-0.237
-41.56	5.986	25.102	-41.579	5.77	25.32	0.019	0.216	-0.217	-0.307
-38.49	4.712	25.18	-38.573	4.603	25.317	0.083	0.109	-0.137	-0.193
-35.322	8.865	27.213	-35.264	8.941	27.543	-0.058	-0.076	-0.33	-0.344
-32.543	12.511	22.05	-32.429	12.661	22.134	-0.114	-0.15	-0.085	-0.206
-30.206	15.578	8.553	-30.142	15.662	8.573	-0.064	-0.084	-0.02	-0.107
-23.786	6.824	8.538	-23.629	6.883	8.569	-0.157	-0.058	-0.031	-0.17
-27.418	5.461	22.014	-27.163	5.556	22.136	-0.255	-0.095	-0.122	-0.298
-31.636	3.887	27.194	-31.541	3.922	27.542	-0.095	-0.035	-0.348	-0.362
-36.583	2.04	25.24	-36.655	2.013	25.317	0.073	0.027	-0.078	-0.11
-36.365	-1.21	25.27	-36.415	-1.199	25.321	0.05	-0.011	-0.051	-0.073
-31.182	-2.286	27.139	-31.067	-2.31	27.54	-0.115	0.024	-0.4	-0.417
-26.848	-3.183	21.967	-26.496	-3.257	22.129	-0.352	0.074	-0.162	-0.395
-22.988	-3.979	8.526	-22.801	-4.018	8.562	-0.187	0.039	-0.036	-0.195
-28.04	-13.56	8.524	-27.913	-13.683	8.557	-0.127	0.123	-0.033	-0.18
-30.895	-10.813	21.959	-30.631	-11.068	22.124	-0.264	0.255	-0.165	-0.402
-34.084	-7.742	27.09	-33.989	-7.834	27.537	-0.095	0.092	-0.447	-0.466
-37.882	-4.084	25.263	-37.927	-4.041	25.325	0.045	-0.043	-0.062	-0.088
-42.15	6.008	25.101	-42.147	5.791	25.319	-0.002	0.218	-0.218	-0.308
-42.196	11.178	27.297	-42.197	11.249	27.541	0.001	-0.071	-0.244	-0.254
-42.239	15.803	22.081	-42.24	15.921	22.134	0.001	-0.118	-0.053	-0.13
-42.272	19.672	8.568	-42.273	19.694	8.572	0	-0.022	-0.004	-0.022
-40.677	1.533	20.38	-40.699	1.509	20.4	0.022	0.023	-0.02	-0.037
-45.309	0.26	21.7	-45.074	0.241	21.861	-0.235	0.019	-0.161	-0.286
-40.765	-2.476	21.591	-40.761	-2.483	21.585	-0.004	0.008	0.006	0.01
45.124	-41.27	15.006	45.114	-41.288	15.141	0.01	0.017	-0.135	-0.137
42.546	-45.99	13.264	42.519	-46.038	13.368	0.027	0.048	-0.104	-0.118
40.384	-49.947	9.817	40.351	-50.007	9.881	0.034	0.06	-0.063	-0.094

38.892	-52.679	5.031	38.861	-52.734	5.057	0.031	0.055	-0.027	-0.068
31.958	-44.739	5.015	31.859	-44.777	5.06	0.098	0.038	-0.045	-0.115
34.876	-43.601	9.765	34.756	-43.648	9.885	0.121	0.047	-0.119	-0.176
39.054	-41.968	13.195	38.968	-42.002	13.37	0.086	0.034	-0.175	-0.198
44.032	-40.023	14.979	44.01	-40.032	15.141	0.022	0.009	-0.162	-0.164
43.995	-38.368	14.954	43.969	-38.36	15.142	0.026	-0.009	-0.188	-0.19
38.928	-36.657	13.194	38.839	-36.627	13.372	0.089	-0.03	-0.178	-0.201
34.724	-35.237	9.722	34.554	-35.18	9.888	0.17	-0.057	-0.165	-0.244
31.764	-34.236	4.996	31.608	-34.183	5.065	0.156	-0.052	-0.07	-0.178
38.311	-26.047	5.001	38.224	-25.906	5.071	0.086	-0.141	-0.07	-0.18
39.939	-28.723	9.725	39.844	-28.566	9.895	0.096	-0.157	-0.17	-0.25
42.229	-32.487	13.256	42.196	-32.433	13.377	0.033	-0.054	-0.121	-0.137
45.027	-37.078	14.97	45.014	-37.056	15.144	0.013	-0.022	-0.174	-0.176
46.65	-36.744	15.024	46.652	-36.726	15.144	-0.003	-0.017	-0.12	-0.121
47.459	-31.422	13.28	47.466	-31.37	13.378	-0.008	-0.051	-0.099	-0.112
48.131	-26.999	9.798	48.147	-26.895	9.896	-0.016	-0.105	-0.098	-0.144
48.606	-23.883	5.047	48.616	-23.817	5.075	-0.01	-0.066	-0.028	-0.073
38.892	-52.678	5.032	38.862	-52.733	5.059	0.031	0.055	-0.027	-0.069
40.384	-49.947	9.818	40.351	-50.007	9.881	0.033	0.06	-0.063	-0.094
42.546	-45.989	13.263	42.519	-46.038	13.369	0.027	0.049	-0.106	-0.119
45.124	-41.27	15.006	45.114	-41.287	15.141	0.01	0.017	-0.135	-0.136
47.45	-37.008	15.058	47.456	-36.996	15.144	-0.006	-0.011	-0.087	-0.088
50.023	-32.294	13.267	50.051	-32.242	13.379	-0.028	-0.052	-0.112	-0.126
52.181	-28.352	9.817	52.224	-28.273	9.9	-0.043	-0.079	-0.083	-0.122
53.685	-25.594	5.051	53.715	-25.538	5.078	-0.03	-0.056	-0.027	-0.069
60.787	-33.468	5.101	60.721	-33.493	5.072	0.066	0.026	0.03	0.077
57.833	-34.627	9.908	57.822	-34.631	9.896	0.012	0.005	0.012	0.017
53.584	-36.286	13.338	53.604	-36.278	13.379	-0.02	-0.008	-0.041	-0.046
48.535	-38.261	14.969	48.559	-38.251	15.144	-0.024	-0.009	-0.175	-0.177
48.591	-39.919	15.076	48.6	-39.922	15.143	-0.009	0.003	-0.067	-0.068
53.747	-41.659	13.404	53.733	-41.654	13.375	0.014	-0.005	0.029	0.033
58.073	-43.119	9.936	58.024	-43.102	9.888	0.049	-0.017	0.048	0.071
61.082	-44.129	5.115	60.972	-44.092	5.065	0.111	-0.037	0.05	0.127
54.382	-52.427	5.092	54.347	-52.37	5.063	0.035	-0.057	0.028	0.072
52.738	-49.733	9.902	52.729	-49.717	9.885	0.01	-0.016	0.017	0.026
50.37	-45.843	13.356	50.375	-45.85	13.373	-0.005	0.007	-0.016	-0.019
47.553	-41.225	15.114	47.555	-41.228	15.142	-0.002	0.004	-0.028	-0.028
45.918	-41.545	15.055	45.916	-41.558	15.141	0.002	0.013	-0.086	-0.087
45.105	-46.893	13.334	45.102	-46.911	13.368	0.003	0.018	-0.035	-0.039
44.435	-51.301	9.803	44.422	-51.383	9.88	0.013	0.083	-0.077	-0.113
43.952	-54.476	5.066	43.956	-54.454	5.057	-0.003	-0.022	0.009	0.024

53.689	-25.593	5.051		53.718	-25.539	5.077		-0.029	-0.054	-0.026		-0.067
52.182	-28.351	9.816		52.225	-28.272	9.899		-0.043	-0.079	-0.083		-0.122
50.022	-32.294	13.269		50.05	-32.243	13.38		-0.028	-0.051	-0.111		-0.125
47.449	-37.008	15.056		47.455	-36.996	15.144		-0.006	-0.011	-0.088		-0.089
32.371	-49.553	0.488		32.356	-49.564	0.513		0.015	0.011	-0.025		-0.031
36.692	-53.883	0.383		36.692	-53.882	0.381		-0.001	-0.001	0.002		0.002
45.174	-56.213	0.937		45.179	-56.128	0.862		-0.006	-0.085	0.074		0.113
54.497	-53.987	1.264		54.419	-53.845	1.16		0.078	-0.141	0.104		0.192
60.81	-47.749	1.423		60.66	-47.66	1.329		0.15	-0.089	0.094		0.198
63.16	-39.397	1.43		62.992	-39.394	1.341		0.168	-0.003	0.089		0.19
5.497	29.297	-10.256		5.497	29.393	-10.227		0	-0.096	-0.029		-0.1
2.129	29.306	-10.253		2.129	29.393	-10.227		0	-0.087	-0.026		-0.091
2.13	26.262	0.302		2.13	26.236	0.294		0	0.026	0.008		0.027
-1.236	29.346	-10.244		-1.236	29.393	-10.229		0	-0.047	-0.014		-0.05
5.497	20.144	-12.346		5.497	20.1	-12.333		0	0.044	-0.013		-0.046
2.129	23.37	-1.845		2.129	23.256	-1.811		0	0.114	-0.034		-0.119
2.13	20.166	-12.352		2.13	20.1	-12.332		0	0.066	-0.02		-0.069
-1.237	20.171	-12.355		-1.237	20.1	-12.334		0	0.071	-0.021		-0.074
8.006	27.589	-10.209		7.916	27.589	-10.245		0.09	0	0.036		0.097
8.018	25.063	-10.205		7.916	25.063	-10.245		0.101	0	0.04		0.109
3.651	25.058	0.255		3.707	25.058	0.277		-0.057	0	-0.023		-0.061
8.017	22.537	-10.206		7.917	22.537	-10.246		0.1	0	0.04		0.108
-4.204	27.59	-12.466		-4.489	27.59	-12.352		0.285	0	-0.114		-0.307
-0.181	25.06	-1.87		-0.28	25.06	-1.83		0.099	0	-0.04		-0.107
-4.15	25.065	-12.489		-4.49	25.065	-12.353		0.34	0	-0.136		-0.366
-4.16	22.539	-12.486		-4.49	22.539	-12.353		0.33	0	-0.132		-0.356
-9.118	5.004	-1.799		-9.223	5.061	-1.799		0.105	-0.058	0		0.12
-9.142	5.012	9.988		-9.225	5.058	9.988		0.083	-0.046	0		0.095
-0.665	10.427	9.99		-0.67	10.499	9.99		0.005	-0.073	0		0.073
-0.658	10.336	-1.794		-0.668	10.5	-1.794		0.01	-0.164	0		0.164
8.512	6.188	-1.793		8.51	6.186	-1.793		0.002	0.002	0		-0.003
8.489	6.167	9.995		8.512	6.183	9.995		-0.023	-0.017	0		0.028
9.927	-3.237	9.987		10.003	-3.261	9.987		-0.075	0.025	0		0.079
9.986	-3.251	1.15		10.004	-3.256	1.15		-0.018	0.006	0		0.019
-0.006	-10.492	1.146		-0.006	-10.521	1.146		0	0.028	0		0.028
-0.007	-10.491	9.985		-0.007	-10.521	9.985		0	0.03	0		0.03
-9.895	-3.221	9.983		-10.004	-3.257	9.983		0.109	0.036	0		0.115
-9.999	-3.251	1.142		-10.005	-3.253	1.142		0.006	0.002	0		0.006
10.686	-10.159	4.088		10.675	-10.149	4.088		0.011	-0.01	0		0.015
-11.225	-9.581	4.089		-11.203	-9.563	4.089		-0.022	-0.019	0		0.029
-14.602	1.922	1.148		-14.603	1.922	1.148		0.001	0	0		-0.001

-8.368	12.164	4.1	-8.348	12.135	4.1	-0.02	0.029	0	0.035
3.43	14.303	1.155	3.435	14.323	1.155	-0.005	-0.02	0	-0.02
12.915	7.005	4.097	12.947	7.022	4.097	-0.032	-0.018	0	-0.037
1.857	1.482	-16.792	1.857	1.441	-16.833	0	0.041	0.041	0.058
-3.818	3.848	-17.142	-3.818	3.848	-16.833	0	0	-0.308	-0.308
-3.9	-4.085	-17.174	-3.9	-4.085	-16.833	0	0	-0.341	-0.341
3.674	-3.939	-17.064	3.674	-3.939	-16.833	0	0	-0.23	-0.23
-0.373	0.223	-21.457	-0.373	0.223	-21.042	0	0	-0.416	-0.416
-9.4	-8.522	12.247	-9.4	-8.522	12.625	0	0	-0.378	-0.378
-12.037	3.535	12.366	-12.037	3.535	12.625	0	0	-0.259	-0.259
-0.967	12.017	12.322	-0.967	12.017	12.625	0	0	-0.303	-0.303
11.196	4.948	12.378	11.196	4.948	12.625	0	0	-0.247	-0.247
10.543	-6.992	12.32	10.543	-6.992	12.625	0	0	-0.305	-0.305
0.406	-12.799	12.255	0.406	-12.799	12.625	0	0	-0.37	-0.37
-0.473	-14.709	7.174	-0.474	-14.722	7.174	0	0.013	0	-0.013
6.947	-46.754	7.018	6.972	-46.754	7.018	-0.025	0	0	-0.025
6.993	-36.748	7.024	6.972	-36.748	7.024	0.021	0	0	0.021
6.984	-26.741	7.029	6.972	-26.741	7.029	0.012	0	0	0.012
6.98	-16.734	7.034	6.972	-16.734	7.034	0.008	0	0	0.008
4.363	-17.693	7.033	4.447	-17.693	7.033	-0.084	0	0	0.084
4.413	-27.416	7.03	4.447	-27.416	7.03	-0.034	0	0	0.034
4.404	-37.138	7.025	4.447	-37.138	7.025	-0.043	0	0	0.043
4.411	-46.861	7.021	4.447	-46.861	7.021	-0.036	0	0	0.036
-3.976	-46.877	9.964	-3.97	-46.877	9.964	-0.006	0	0	-0.006
-3.913	-37.192	9.966	-3.97	-37.192	9.966	0.057	0	0	0.057
-3.928	-27.508	9.972	-3.97	-27.508	9.972	0.042	0	0	0.042
-3.934	-17.824	9.976	-3.97	-17.824	9.976	0.036	0	0	0.036
-8.223	-16.078	4.087	-8.178	-16.078	4.087	-0.045	0	0	0.045
-8.226	-26.281	4.082	-8.178	-26.281	4.082	-0.048	0	0	0.048
-8.184	-36.481	4.077	-8.178	-36.481	4.077	-0.006	0	0	0.006
-8.249	-46.68	4.073	-8.178	-46.68	4.073	-0.071	0	0	0.071
-6.092	-50.513	7.466	-6.092	-50.5	7.466	0	-0.013	0	0.013
5.661	-50.432	10.702	5.661	-50.5	10.702	0	0.068	0	-0.068
5.658	-46.526	12.36	5.658	-46.526	12.625	0	0	-0.265	-0.265
5.68	-37.482	12.4	5.68	-37.482	12.625	0	0	-0.225	-0.225
5.587	-28.438	12.309	5.587	-28.438	12.625	0	0	-0.316	-0.316
5.815	-17.471	12.32	5.815	-17.471	12.625	0	0	-0.305	-0.305
-6.174	-16.914	12.257	-6.174	-16.914	12.625	0	0	-0.368	-0.368
-6.295	-27.316	12.258	-6.295	-27.316	12.625	0	0	-0.367	-0.367
-6.319	-36.135	12.289	-6.319	-36.135	12.625	0	0	-0.336	-0.336
-5.859	-47.887	12.445	-5.859	-47.887	12.625	0	0	-0.18	-0.18

62.978	-85.759	0.299	62.978	-85.759	0	0	0	0.299	0.299
51.549	-86.129	0.237	51.549	-86.129	0	0	0	0.237	0.237
30.804	-85.65	0.195	30.804	-85.65	0	0	0	0.195	0.195
26.818	-77.932	0.147	26.818	-77.932	0	0	0	0.147	0.147
40.004	-79.657	0.13	40.004	-79.657	0	0	0	0.13	0.13
56.44	-76.268	0.241	56.44	-76.268	0	0	0	0.241	0.241
61.089	-66.969	0.224	61.089	-66.969	0	0	0	0.224	0.224
47.097	-70.221	0.194	47.097	-70.221	0	0	0	0.194	0.194
37.578	-65.825	0.065	37.578	-65.825	0	0	0	0.065	0.065
23.929	-65.496	0.082	23.929	-65.496	0	0	0	0.082	0.082
19.966	-53.395	0.027	19.966	-53.395	0	0	0	0.027	0.027
15.198	-46.268	-0.06	15.198	-46.268	0	0	0	-0.06	-0.06
23.608	-45.523	-0.027	23.608	-45.523	0	0	0	-0.027	-0.027
14.848	-35.334	-0.09	14.848	-35.334	0	0	0	-0.09	-0.09
15.712	-25.374	-0.117	15.712	-25.374	0	0	0	-0.117	-0.117
25.625	-28.31	-0.078	25.625	-28.31	0	0	0	-0.078	-0.078
33.61	-23.317	0.03	33.61	-23.317	0	0	0	0.03	0.03
61.7	-24.463	0.118	61.7	-24.463	0	0	0	0.118	0.118
68.08	-34.982	0.171	68.08	-34.982	0	0	0	0.171	0.171
65.275	-54.954	0.224	65.275	-54.954	0	0	0	0.224	0.224
68.934	-6.533	0.099	68.934	-6.533	0	0	0	0.099	0.099
66.107	18.464	0.097	66.107	18.464	0	0	0	0.097	0.097
52.199	19.042	0.083	52.199	19.042	0	0	0	0.083	0.083
38.324	18.793	-0.003	38.324	18.793	0	0	0	-0.003	-0.003
24.97	19.116	-0.03	24.97	19.116	0	0	0	-0.03	-0.03
27.073	28.575	0.054	27.073	28.575	0	0	0	0.054	0.054
34.214	26.913	0.022	34.214	26.913	0	0	0	0.022	0.022
45.956	25.978	0.052	45.956	25.978	0	0	0	0.052	0.052
45.64	34.518	0.168	45.64	34.518	0	0	0	0.168	0.168
29.666	39.432	0.059	29.666	39.432	0	0	0	0.059	0.059
17.309	42.275	0.077	17.309	42.275	0	0	0	0.077	0.077
7.07	39.404	0.037	7.07	39.404	0	0	0	0.037	0.037
10.238	49.455	0.104	10.238	49.455	0	0	0	0.104	0.104
22.927	52.418	0.121	22.927	52.418	0	0	0	0.121	0.121
43.228	55.669	0.305	43.228	55.669	0	0	0	0.305	0.305
66.421	54.338	0.437	66.421	54.338	0	0	0	0.437	0.437
67.008	38.359	0.211	67.008	38.359	0	0	0	0.211	0.211
-12.216	40.877	-0.029	-12.216	40.877	0	0	0	-0.029	-0.029
-22.791	17.584	-0.117	-22.791	17.584	0	0	0	-0.117	-0.117
-24.094	30.775	-0.056	-24.094	30.775	0	0	0	-0.056	-0.056
-31.273	26.089	0.029	-31.273	26.089	0	0	0	0.029	0.029

-43.002	26.75	0.046	-43.002	26.75	0	0	0	0.046	0.046
-50.496	30.604	0.029	-50.496	30.604	0	0	0	0.029	0.029
-40.449	46.154	0.134	-40.449	46.154	0	0	0	0.134	0.134
-47.572	54.711	0.22	-47.572	54.711	0	0	0	0.22	0.22
-75.583	53.928	0.449	-75.583	53.928	0	0	0	0.449	0.449
-75.8	37.645	0.328	-75.8	37.645	0	0	0	0.328	0.328
-74.584	19.486	0.218	-74.584	19.486	0	0	0	0.218	0.218
-57.107	25.389	0.169	-57.107	25.389	0	0	0	0.169	0.169
-66.146	12.082	0.219	-66.146	12.082	0	0	0	0.219	0.219
-68.658	-0.977	0.217	-68.658	-0.977	0	0	0	0.217	0.217
-77.012	-10.67	0.194	-77.012	-10.67	0	0	0	0.194	0.194
-76.875	-29.146	0.131	-76.875	-29.146	0	0	0	0.131	0.131
-62.608	-24.744	0.075	-62.608	-24.744	0	0	0	0.075	0.075
-49.922	-21.782	-0.096	-49.922	-21.782	0	0	0	-0.096	-0.096
-35.594	-26.481	-0.034	-35.594	-26.481	0	0	0	-0.034	-0.034
-22.839	-18	-0.174	-22.839	-18	0	0	0	-0.174	-0.174
-27.85	-36.944	-0.051	-27.85	-36.944	0	0	0	-0.051	-0.051
-13.721	-51.025	-0.123	-13.721	-51.025	0	0	0	-0.123	-0.123
-5.221	-60.081	-0.017	-5.221	-60.081	0	0	0	-0.017	-0.017
-6.458	-70.883	0.062	-6.458	-70.883	0	0	0	0.062	0.062
-7.802	-86.102	0.154	-7.802	-86.102	0	0	0	0.154	0.154
-27.231	-90.697	0.141	-27.231	-90.697	0	0	0	0.141	0.141
-40.922	-88.456	0.199	-40.922	-88.456	0	0	0	0.199	0.199
-53.679	-82.044	0.224	-53.679	-82.044	0	0	0	0.224	0.224
-62.887	-90.666	0.372	-62.887	-90.666	0	0	0	0.372	0.372
-77.214	-85.967	0.487	-77.214	-85.967	0	0	0	0.487	0.487
-75.558	-64.393	0.333	-75.558	-64.393	0	0	0	0.333	0.333
-71.95	-44.126	0.243	-71.95	-44.126	0	0	0	0.243	0.243
-65.796	-56.028	0.218	-65.796	-56.028	0	0	0	0.218	0.218
-62.169	-65.819	0.302	-62.169	-65.819	0	0	0	0.302	0.302
-50.453	-58.757	-0.001	-50.453	-58.757	0	0	0	-0.001	-0.001
-50.207	-72.812	0.137	-50.207	-72.812	0	0	0	0.137	0.137
-14.081	-37.877	-16.916	-14.081	-37.877	-16.833	0	0	-0.082	-0.082
-14.477	-16.479	-17.106	-14.477	-16.479	-16.833	0	0	-0.273	-0.273
-13.66	16.198	-17.13	-13.66	16.198	-16.833	0	0	-0.296	-0.296
-13.491	29.404	-17.068	-13.491	29.404	-16.833	0	0	-0.235	-0.235
14.568	31.667	-16.979	14.568	31.667	-16.833	0	0	-0.146	-0.146
15.436	23.96	-17.067	15.436	23.96	-16.833	0	0	-0.233	-0.233
15.7	12.27	-17.092	15.7	12.27	-16.833	0	0	-0.259	-0.259
59.887	4.356	-16.871	59.887	4.356	-16.833	0	0	-0.037	-0.037
58.328	-9.916	-16.887	58.328	-9.916	-16.833	0	0	-0.053	-0.053

48.836	-15.209	-16.977	48.836	-15.209	-16.833	0	0	-0.144	-0.144
36.426	-9.615	-16.963	36.426	-9.615	-16.833	0	0	-0.129	-0.129
30.657	-17.638	-17.022	30.657	-17.638	-16.833	0	0	-0.189	-0.189
13.198	-15.12	-17.094	13.198	-15.12	-16.833	0	0	-0.261	-0.261
19.487	2.858	-4.517	19.487	2.858	-4.208	0	0	-0.308	-0.308
28.874	7.266	-4.486	28.874	7.266	-4.208	0	0	-0.278	-0.278
34.399	3.008	-4.393	34.399	3.008	-4.208	0	0	-0.185	-0.185
41.154	7.389	-4.39	41.154	7.389	-4.208	0	0	-0.182	-0.182
46.38	2.203	-4.378	46.38	2.203	-4.208	0	0	-0.169	-0.169
51.976	8.422	-4.346	51.976	8.422	-4.208	0	0	-0.138	-0.138
50.807	-3.174	0.131	50.807	-3.174	0	0	0	0.131	0.131
40.284	-2.971	-0.024	40.284	-2.971	0	0	0	-0.024	-0.024
28.591	-2.78	-0.065	28.591	-2.78	0	0	0	-0.065	-0.065
16.903	-1.974	-0.086	16.903	-1.974	0	0	0	-0.086	-0.086
18.522	-9.302	1.512	18.522	-9.302	1.683	0	0	-0.171	-0.171
24.681	-6.468	1.481	24.681	-6.468	1.683	0	0	-0.203	-0.203
25.794	-14.775	1.562	25.794	-14.775	1.683	0	0	-0.121	-0.121
18.753	-12.445	-3.806	18.753	-12.447	-3.806	0	0.002	0	-0.002
25.652	-16.641	0.577	25.652	-16.655	0.577	0	0.014	0	-0.014
32.961	-4.087	-3.864	32.961	-4.03	-3.864	0	-0.057	0	0.057
39.985	-4.067	-3.109	39.985	-4.03	-3.109	0	-0.036	0	0.036
52.606	-4.052	-4.384	52.606	-4.03	-4.384	0	-0.021	0	0.021
55.579	0.006	-8.659	55.263	0.107	-8.659	0.316	-0.101	0	0.332
56.852	7.941	-9.4	56.527	7.941	-9.4	0.324	0	0	0.324
59.439	12.483	-0.481	59.439	12.516	-0.552	0	-0.033	0.071	0.079
49.224	13.375	-1.332	49.224	13.341	-1.274	0	0.034	-0.058	-0.067
39.386	12.595	-1.173	39.386	12.561	-1.139	0	0.034	-0.034	-0.049

### 3D-Tol Data from CMM for Alumide Titanium Casting

MEAS X	MEAS Y	MEAS Z	CAD X	CAD Y	CAD Z	DIF X	DIF Y	DIF Z	TOT DIF
53.832	58.833	-5.871	53.832	58.917	-5.871	0	-0.083	0	-0.083
37.286	58.755	-5.88	37.286	58.917	-5.88	0	-0.161	0	-0.161
20.742	58.666	-5.89	20.742	58.917	-5.89	0	-0.25	0	-0.25
4.197	58.607	-5.901	4.197	58.917	-5.901	0	-0.31	0	-0.31
-12.348	58.545	-5.91	-12.348	58.917	-5.91	0	-0.371	0	-0.371
-28.893	58.486	-5.921	-28.893	58.917	-5.921	0	-0.431	0	-0.431
-45.437	58.514	-5.931	-45.437	58.917	-5.931	0	-0.403	0	-0.403
-61.983	58.481	-5.942	-61.983	58.917	-5.942	0	-0.436	0	-0.436
-79.767	41.181	-5.983	-79.958	41.181	-5.983	0.191	0	0	-0.191
-79.726	24.636	-6.009	-79.958	24.636	-6.009	0.232	0	0	-0.232

-79.714	8.092	-6.035	-79.958	8.092	-6.035	0.245	0	0	-0.245
-79.698	-8.452	-6.061	-79.958	-8.452	-6.061	0.261	0	0	-0.261
-79.639	-24.998	-6.086	-79.958	-24.998	-6.086	0.319	0	0	-0.319
-79.619	-41.542	-6.112	-79.958	-41.542	-6.112	0.339	0	0	-0.339
-79.611	-58.087	-6.138	-79.958	-58.087	-6.138	0.348	0	0	-0.348
-79.644	-74.632	-6.163	-79.958	-74.632	-6.163	0.315	0	0	-0.315
-62.127	-92.475	-6.184	-62.127	-92.583	-6.184	0	0.108	0	-0.108
-45.582	-92.429	-6.173	-45.582	-92.583	-6.173	0	0.154	0	-0.154
-29.037	-92.409	-6.163	-29.037	-92.583	-6.163	0	0.175	0	-0.175
-12.493	-92.432	-6.153	-12.493	-92.583	-6.153	0	0.151	0	-0.151
4.052	-92.441	-6.143	4.052	-92.583	-6.143	0	0.142	0	-0.142
20.597	-92.484	-6.133	20.597	-92.583	-6.133	0	0.099	0	-0.099
37.142	-92.483	-6.122	37.142	-92.583	-6.122	0	0.1	0	-0.1
53.686	-92.535	-6.112	53.686	-92.583	-6.112	0	0.048	0	-0.048
71.406	-74.779	-6.072	71.542	-74.779	-6.072	-0.135	0	0	-0.135
71.399	-58.234	-6.044	71.542	-58.234	-6.044	-0.143	0	0	-0.143
71.334	-41.689	-6.019	71.542	-41.689	-6.019	-0.207	0	0	-0.207
71.217	-25.143	-5.991	71.542	-25.143	-5.991	-0.324	0	0	-0.324
71.087	-8.599	-5.965	71.542	-8.599	-5.965	-0.454	0	0	-0.454
71.066	7.945	-5.939	71.542	7.945	-5.939	-0.476	0	0	-0.476
71.112	24.49	-5.915	71.542	24.49	-5.915	-0.43	0	0	-0.43
71.133	41.035	-5.888	71.542	41.035	-5.888	-0.409	0	0	-0.409
-69.749	43.841	8.353	-69.749	43.841	8.417	0	0	-0.064	-0.064
-64.696	43.836	8.316	-64.696	43.836	8.417	0	0	-0.101	-0.101
-64.693	48.886	8.352	-64.693	48.886	8.417	0	0	-0.065	-0.065
-69.744	48.89	8.408	-69.744	48.89	8.417	0	0	-0.009	-0.009
-67.613	46.482	8.372	-67.613	46.482	8.417	0	0	-0.044	-0.044
-71.764	43.848	6.651	-71.542	43.848	6.651	-0.222	0	0	0.222
-71.861	48.898	6.662	-71.542	48.898	6.662	-0.319	0	0	0.319
-69.741	50.49	6.665	-69.741	50.5	6.665	0	-0.01	0	-0.01
-64.689	50.453	6.668	-64.689	50.5	6.668	0	-0.047	0	-0.047
-64.699	42.602	6.649	-64.699	42.083	6.649	0	0.519	0	-0.519
-69.749	42.563	6.648	-69.749	42.083	6.648	0	0.48	0	-0.48
-63.072	49.872	6.662	-63.125	50.5	6.662	0.053	-0.628	0	0.631
-63.059	43.839	7.637	-63.125	43.839	8.417	0.066	0	-0.78	0.783
-64.752	-14.232	4.148	-64.752	-14.232	4.208	0	0	-0.06	-0.06
-69.802	-14.228	4.119	-69.802	-14.228	4.208	0	0	-0.089	-0.089
-69.806	-19.278	4.166	-69.806	-19.278	4.208	0	0	-0.043	-0.043
-64.755	-19.282	4.172	-64.755	-19.282	4.208	0	0	-0.037	-0.037
-67.925	-16.657	4.128	-67.925	-16.657	4.208	0	0	-0.081	-0.081
-69.8	-12.516	4.034	-69.8	-12.625	4.208	0	0.109	-0.174	0.206

-64.749	-12.519	4.038	-64.749	-12.625	4.208	0	0.106	-0.17	0.2
-63.113	-14.23	4.157	-63.125	-14.23	4.208	0.012	0	-0.051	0.053
-63.109	-19.281	4.146	-63.125	-19.281	4.208	0.016	0	-0.062	0.064
-64.759	-21.111	3.183	-64.759	-21.042	3.183	0	-0.069	0	0.069
-69.808	-21.11	3.183	-69.808	-21.042	3.183	0	-0.068	0	0.068
-71.952	-19.271	3.186	-71.542	-19.271	3.186	-0.41	0	0	0.41
-71.959	-14.221	3.197	-71.542	-14.221	3.197	-0.417	0	0	0.417
-64.816	-77.363	8.005	-64.816	-77.363	8.417	0	0	-0.411	-0.411
-69.866	-77.36	8.125	-69.866	-77.36	8.417	0	0	-0.292	-0.292
-69.869	-82.41	8.226	-69.869	-82.41	8.417	0	0	-0.19	-0.19
-64.818	-82.414	8.198	-64.818	-82.414	8.417	0	0	-0.219	-0.219
-70.849	-75.737	6.467	-71.542	-75.75	6.467	0.692	0.013	0	0.692
-64.813	-76.933	6.469	-64.813	-75.75	6.469	0	-1.183	0	-1.183
-63.112	-76.375	6.466	-63.125	-75.75	6.466	0.013	-0.625	0	0.625
-63.965	-82.411	6.458	-63.125	-82.411	6.458	-0.84	0	0	-0.84
-64.822	-84.542	6.45	-64.822	-84.167	6.45	0	-0.375	0	0.375
-69.871	-84.641	6.45	-69.871	-84.167	6.45	0	-0.474	0	0.474
-71.773	-82.402	6.455	-71.542	-82.402	6.455	-0.231	0	0	0.231
-71.677	-77.352	6.465	-71.542	-77.352	6.465	-0.136	0	0	0.136
-2.412	43.782	3.845	-2.412	43.782	4.208	0	0	-0.363	-0.363
2.64	43.778	3.807	2.64	43.778	4.208	0	0	-0.401	-0.401
2.642	48.829	3.739	2.642	48.829	4.208	0	0	-0.469	-0.469
-2.407	48.832	3.754	-2.407	48.832	4.208	0	0	-0.455	-0.455
-0.569	46.813	3.811	-0.569	46.813	4.208	0	0	-0.398	-0.398
-4.231	43.79	2.064	-4.208	43.79	2.064	-0.023	0	0	0.023
-4.261	48.84	2.075	-4.208	48.84	2.075	-0.053	0	0	0.053
3.599	41.948	2.062	4.208	42.083	2.062	-0.609	-0.135	0	0.624
-2.412	42.692	2.063	-2.412	42.083	2.063	0	0.608	0	-0.608
3.909	48.832	2.076	4.208	48.832	2.076	-0.299	0	0	-0.299
3.891	43.781	2.068	4.208	43.781	2.068	-0.317	0	0	-0.317
-2.404	50.936	2.078	-2.404	50.5	2.078	0	0.436	0	0.436
2.647	50.937	2.082	2.647	50.5	2.082	0	0.437	0	0.437
-64.586	36.21	-0.422	-64.688	36.312	0	0.102	-0.102	-0.422	0.446
-53.888	46.943	-0.387	-53.973	47.027	0	0.085	-0.085	-0.387	0.405
-46.954	46.855	-1.327	-46.904	46.904	-1.327	-0.049	-0.049	0	0.07
-36.239	36.142	-1.337	-36.191	36.191	-1.337	-0.049	-0.049	0	0.069
-41.123	28.894	-1.347	-40.96	29.057	-1.347	-0.163	-0.163	0	-0.231
-48.269	36.028	-1.339	-48.1	36.197	-1.339	-0.169	-0.169	0	-0.239
-35.967	29.969	-1.723	-35.645	29.646	-1.723	-0.322	0.322	0	0.456
-54.359	35.494	-1.346	-53.981	35.116	-1.346	-0.378	0.378	0	0.535
-59.091	30.71	-1.352	-58.739	30.358	-1.352	-0.352	0.352	0	0.497

-65.589	29.407	-1.263	-65.352	29.643	-1.263		-0.237	-0.237	0	-0.335
-61.286	33.646	-4.525	-61.286	33.646	-4.208		0	0	-0.316	-0.316
-56.713	38.397	-4.465	-56.713	38.397	-4.208		0	0	-0.257	-0.257
-50.212	43.793	-4.488	-50.212	43.793	-4.208		0	0	-0.279	-0.279
-44.657	38.74	-4.388	-44.657	38.74	-4.208		0	0	-0.18	-0.18
-39.987	33.926	-4.368	-39.987	33.926	-4.208		0	0	-0.16	-0.16
49.769	42.891	5.882	49.769	42.083	5.882		0	0.808	0	-0.808
43.035	42.859	5.878	43.035	42.083	5.878		0	0.775	0	-0.775
55.206	30.259	5.867	54.708	30.259	5.867		0.498	0	0	-0.498
55.188	36.993	5.879	54.708	36.993	5.879		0.48	0	0	-0.48
58.892	25.953	5.364	58.892	25.25	5.364		0	0.703	0	-0.703
63.149	30.251	5.871	63.125	30.251	5.871		0.024	0	0	0.024
63.145	37.826	5.885	63.125	37.826	5.885		0.02	0	0	0.02
63.099	45.402	5.897	63.125	45.402	5.897		-0.026	0	0	-0.026
58.194	50.885	5.904	58.194	50.5	5.904		0	0.385	0	0.385
50.617	50.857	5.901	50.617	50.5	5.901		0	0.357	0	0.357
43.043	50.816	5.896	43.043	50.5	5.896		0	0.316	0	0.316
38.182	46.22	5.164	37.875	46.22	5.164		0.307	0	0	-0.307
43.289	46.377	8.073	43.289	46.377	8.417		0	0	-0.344	-0.344
50.521	46.078	8.191	50.521	46.078	8.417		0	0	-0.226	-0.226
58.492	45.739	8.358	58.492	45.739	8.417		0	0	-0.059	-0.059
59.224	37.473	8.432	59.224	37.473	8.417		0	0	0.015	0.015
59.093	30.628	8.542	59.093	30.628	8.417		0	0	0.125	0.125
-30.793	49.213	16.73	-30.793	48.853	16.938		0	0.36	-0.208	-0.415
-30.793	46.272	11.723	-30.793	45.95	11.909		0	0.323	-0.186	-0.373
-30.793	43.307	6.734	-30.793	43.048	6.883		0	0.259	-0.149	-0.299
-30.793	40.424	1.695	-30.793	40.145	1.856		0	0.279	-0.161	-0.322
-27.003	40.442	1.687	-27.003	40.146	1.857		0	0.295	-0.17	-0.341
-27.004	43.347	6.71	-27.004	43.048	6.883		0	0.299	-0.172	-0.345
-27.004	46.295	11.709	-27.004	45.95	11.909		0	0.345	-0.199	-0.399
-27.005	49.217	16.726	-27.005	48.852	16.936		0	0.365	-0.211	-0.422
-23.216	49.237	16.714	-23.216	48.852	16.937		0	0.385	-0.222	-0.445
-23.217	46.3	11.706	-23.217	45.949	11.909		0	0.35	-0.202	-0.404
-23.217	43.371	6.697	-23.217	43.048	6.883		0	0.323	-0.187	-0.373
-23.217	40.447	1.687	-23.217	40.148	1.86		0	0.299	-0.173	-0.345
-16.9	45.852	1.732	-16.9	45.402	1.852		0	0.45	-0.121	-0.466
-16.9	47.891	9.26	-16.9	47.42	9.386		0	0.47	-0.126	-0.487
-16.904	50.048	17.276	-16.904	50.354	17.358		0	-0.306	-0.082	0.317
-11.854	50.011	17.287	-11.854	50.349	17.378		0	-0.338	-0.091	0.35
-11.852	47.91	9.26	-11.852	47.421	9.391		0	0.489	-0.131	-0.506
-11.849	45.869	1.73	-11.849	45.402	1.855		0	0.467	-0.125	-0.484

-8.739	49.636	7.491		-8.178	49.636	7.491	-0.561	0	0	-0.561
-30.79	51.499	15.171		-30.79	50.978	15.032	0	0.522	0.14	0.54
-30.785	52.991	9.509		-30.785	52.493	9.375	0	0.498	0.133	0.515
-30.781	54.407	3.829		-30.781	54.008	3.722	0	0.399	0.107	0.413
-24.046	54.39	3.831		-24.046	54.006	3.728	0	0.384	0.103	0.398
-24.051	52.99	9.516		-24.051	52.491	9.382	0	0.499	0.134	0.516
-24.055	51.507	15.18		-24.055	50.976	15.038	0	0.532	0.142	0.55
-17.322	51.485	15.178		-17.322	50.975	15.041	0	0.51	0.137	0.528
-17.319	52.967	9.515		-17.319	52.49	9.387	0	0.477	0.128	0.494
-17.312	54.402	3.84		-17.312	54.005	3.734	0	0.397	0.106	0.411
-10.579	54.395	3.845		-10.579	54.003	3.74	0	0.392	0.105	0.406
-10.584	52.963	9.521		-10.584	52.488	9.394	0	0.474	0.127	0.491
-10.588	51.418	15.167		-10.588	50.973	15.047	0	0.445	0.119	0.461
-33.344	48.998	9.622		-33.428	48.998	9.622	0.084	0	0	-0.084
5.198	-63.138	18.604		4.999	-63.138	18.657	0.199	0	-0.053	-0.206
3.263	-63.125	11.548		3.105	-63.125	11.59	0.157	0	-0.042	-0.163
1.416	-63.112	4.467		1.212	-63.112	4.522	0.205	0	-0.055	-0.212
1.475	-69.846	4.441		1.209	-69.846	4.513	0.266	0	-0.071	-0.275
3.291	-69.859	11.529		3.103	-69.859	11.58	0.189	0	-0.051	-0.195
5.208	-69.872	18.589		4.996	-69.872	18.646	0.212	0	-0.057	-0.22
5.245	-76.605	18.568		4.993	-76.605	18.635	0.252	0	-0.067	-0.261
3.351	-76.591	11.5		3.099	-76.591	11.567	0.251	0	-0.067	-0.26
1.528	-76.578	4.414		1.206	-76.578	4.5	0.322	0	-0.086	-0.333
1.485	-83.313	4.414		1.203	-83.313	4.489	0.282	0	-0.076	-0.292
3.363	-83.326	11.486		3.097	-83.326	11.557	0.266	0	-0.071	-0.275
5.281	-83.338	18.548		4.991	-83.338	18.626	0.291	0	-0.078	-0.301
7.443	-86.221	10.123		7.443	-85.85	10.123	0	-0.371	0	0.371
8.082	-83.344	21.216		7.769	-83.344	21.036	0.313	0	0.181	0.361
13.476	-83.336	11.768		13.209	-83.336	11.614	0.267	0	0.154	0.308
18.888	-83.326	2.328		18.649	-83.326	2.191	0.239	0	0.138	0.276
18.857	-75.75	2.32		18.645	-75.75	2.198	0.211	0	0.122	0.244
13.433	-75.761	11.754		13.204	-75.761	11.622	0.229	0	0.132	0.264
8.061	-75.771	21.215		7.764	-75.771	21.044	0.296	0	0.171	0.342
7.252	-69.455	21.08		6.995	-69.455	21.011	0.257	0	0.069	0.266
9.753	-69.443	11.646		9.521	-69.443	11.584	0.232	0	0.062	0.24
12.244	-69.431	2.215		12.046	-69.431	2.161	0.199	0	0.053	0.206
12.293	-64.382	2.235		12.044	-64.382	2.169	0.249	0	0.067	0.258
9.775	-64.395	11.66		9.519	-64.395	11.591	0.256	0	0.069	0.265
7.22	-64.407	21.078		6.994	-64.407	21.017	0.226	0	0.061	0.234
6.449	-61.699	10.914		6.449	-60.6	10.914	0	-1.099	0	-1.099
-30.471	-50.947	-5.065		-30.495	-50.562	-5.505	0.024	-0.385	0.44	0.585

-30.189	-55.373	-7.331	-30.205	-55.1	-7.849	0.017	-0.274	0.519	0.587
-29.955	-59.075	-11.505	-29.982	-58.631	-11.736	0.027	-0.444	0.232	0.501
-29.778	-61.821	-15.616	-29.79	-61.614	-15.911	0.012	-0.207	0.295	0.36
-33.525	-63.588	-15.691	-33.648	-63.474	-15.934	0.123	-0.113	0.242	0.295
-35.735	-61.61	-11.647	-35.892	-61.467	-11.757	0.157	-0.143	0.111	0.24
-38.404	-59.229	-7.552	-38.526	-59.119	-7.861	0.122	-0.11	0.309	0.35
-41.767	-56.214	-5.291	-41.915	-56.081	-5.52	0.148	-0.133	0.229	0.303
-46.334	-68.036	-5.695	-46.204	-68.031	-5.543	-0.131	-0.005	-0.152	-0.201
-41.652	-67.821	-7.904	-41.641	-67.821	-7.884	-0.011	0	-0.021	-0.023
-38.282	-67.657	-11.86	-38.144	-67.652	-11.788	-0.138	-0.005	-0.072	-0.156
-35.173	-67.51	-16.055	-35.11	-67.508	-15.962	-0.063	-0.002	-0.093	-0.112
-33.407	-71.518	-16.181	-33.316	-71.422	-15.984	-0.09	-0.096	-0.197	-0.237
-35.71	-74	-12.051	-35.395	-73.664	-11.812	-0.315	-0.336	-0.239	-0.519
-37.858	-76.318	-8.16	-37.763	-76.216	-7.901	-0.096	-0.102	-0.258	-0.294
-41.063	-79.765	-5.886	-40.877	-79.567	-5.564	-0.185	-0.199	-0.321	-0.421
-29.394	-67.478	-17.104	-29.521	-67.448	-16.852	0.127	-0.03	-0.252	-0.284
-26.803	-62.439	-15.681	-26.726	-62.297	-15.91	-0.077	-0.142	0.23	0.28
-25.529	-60.114	-11.474	-25.29	-59.675	-11.734	-0.239	-0.439	0.261	0.564
-23.74	-56.85	-7.254	-23.589	-56.574	-7.85	-0.151	-0.276	0.596	0.674
-21.641	-53.018	-4.952	-21.407	-52.59	-5.509	-0.234	-0.428	0.557	0.741
-13.669	-62.661	-5.166	-13.369	-62.573	-5.526	-0.3	-0.089	0.361	0.477
-17.952	-63.912	-7.431	-17.732	-63.846	-7.862	-0.22	-0.065	0.431	0.488
-21.441	-64.916	-11.58	-21.12	-64.82	-11.754	-0.32	-0.097	0.174	0.377
-24.108	-65.692	-15.781	-24.009	-65.662	-15.931	-0.1	-0.031	0.15	0.183
-24.44	-69.99	-15.999	-24.462	-69.979	-15.963	0.022	-0.012	-0.037	-0.044
-21.761	-71.463	-11.805	-21.798	-71.443	-11.784	0.037	-0.02	-0.022	-0.047
-18.782	-73.11	-7.776	-18.732	-73.137	-7.882	-0.05	0.027	0.106	0.12
-14.718	-75.337	-5.565	-14.733	-75.329	-5.546	0.015	-0.008	-0.02	-0.026
-24.671	-83.609	-5.837	-24.736	-83.388	-5.565	0.065	-0.221	-0.273	-0.357
-25.99	-79.09	-8.076	-26.017	-78.999	-7.9	0.027	-0.092	-0.176	-0.2
-26.874	-76.044	-12.024	-26.99	-75.653	-11.812	0.116	-0.391	-0.211	-0.459
-27.795	-72.87	-16.212	-27.839	-72.722	-15.981	0.044	-0.148	-0.231	-0.278
-32.234	-72.359	-16.176	-32.173	-72.249	-15.988	-0.06	-0.11	-0.188	-0.226
-33.823	-75.396	-12.069	-33.619	-74.949	-11.814	-0.205	-0.448	-0.255	-0.554
-35.344	-78.135	-8.177	-35.285	-77.998	-7.905	-0.059	-0.136	-0.272	-0.31
-37.59	-82.277	-5.904	-37.479	-82.015	-5.569	-0.111	-0.262	-0.336	-0.441
-25.39	-86.436	-1	-25.451	-86.15	-0.691	0.061	-0.286	-0.309	-0.425
-12.919	-77.23	-1.036	-13.091	-77.128	-0.861	0.171	-0.102	-0.175	-0.265
-11.395	-61.841	-0.536	-11.143	-61.764	-0.786	-0.252	-0.077	0.25	0.364
-16.55	-53.97	-0.163	-16.136	-53.541	-0.752	-0.415	-0.429	0.589	0.838
-25.892	-48.844	0.018	-25.794	-48.337	-0.595	-0.098	-0.507	0.612	0.801

-47.601	-37.904	18.477	-47.133	-37.679	18.777	-0.468	-0.225	-0.3	-0.6
-44.194	-36.285	12.235	-43.839	-36.115	12.462	-0.355	-0.17	-0.227	-0.455
-40.803	-34.673	5.985	-40.547	-34.551	6.149	-0.256	-0.122	-0.164	-0.327
-39.804	-41.261	6.071	-39.657	-41.288	6.157	-0.147	0.027	-0.086	-0.172
-43.489	-40.576	12.327	-43.242	-40.621	12.472	-0.247	0.045	-0.145	-0.29
-47.197	-39.89	18.566	-46.825	-39.956	18.784	-0.372	0.066	-0.218	-0.436
-47.916	-41.988	18.79	-47.916	-41.989	18.79	-0.001	0.001	0	-0.001
-45.356	-44.688	12.524	-45.409	-44.633	12.48	0.053	-0.055	0.044	0.088
-42.81	-47.374	6.244	-42.902	-47.278	6.168	0.091	-0.096	0.077	0.153
-49.008	-50.664	6.434	-49.066	-50.219	6.175	0.058	-0.444	0.259	0.518
-49.479	-47.044	12.742	-49.537	-46.606	12.487	0.058	-0.438	0.255	0.51
-49.953	-43.4	19.036	-50.007	-42.992	18.799	0.054	-0.408	0.238	0.475
-52.659	-43.242	19.248	-52.289	-42.565	18.802	-0.371	-0.677	0.445	0.891
-54.397	-46.409	12.913	-54.042	-45.762	12.487	-0.355	-0.647	0.426	0.852
-56.118	-49.555	6.568	-55.791	-48.958	6.175	-0.327	-0.596	0.393	0.785
-52.738	-40.341	23.129	-51.892	-39.948	22.591	-0.846	-0.394	0.539	1.077
-57.921	-42.772	12.96	-57.175	-42.423	12.485	-0.745	-0.349	0.475	0.95
-62.995	-45.156	2.732	-62.453	-44.902	2.386	-0.542	-0.254	0.346	0.691
-63.93	-36.693	2.656	-63.462	-36.784	2.381	-0.468	0.091	0.275	0.55
-58.366	-37.765	12.854	-57.735	-37.888	12.483	-0.631	0.123	0.371	0.743
-52.661	-38.865	22.967	-52.009	-38.996	22.583	-0.651	0.131	0.384	0.767
-51.635	-38.059	22.651	-51.543	-38.159	22.572	-0.092	0.1	0.079	0.157
-55.716	-33.698	12.632	-55.527	-33.901	12.472	-0.189	0.203	0.16	0.32
-59.641	-29.504	2.483	-59.511	-29.643	2.373	-0.13	0.14	0.11	0.221
-52.133	-26.231	2.339	-52.139	-26.189	2.364	0.005	-0.043	-0.025	-0.05
-51.398	-32.059	12.418	-51.408	-31.976	12.466	0.01	-0.083	-0.048	-0.097
-50.023	-37.827	22.774	-49.804	-38.025	22.734	-0.219	0.199	0.04	0.298
-50.018	-38.403	22.255	-49.756	-37.938	22.562	-0.262	-0.464	-0.308	-0.616
-47.129	-33.116	12.265	-46.96	-32.821	12.462	-0.169	-0.296	-0.197	-0.393
-44.273	-27.893	2.236	-44.165	-27.704	2.362	-0.109	-0.19	-0.126	-0.252
-46.147	3.935	25.033	-46.093	3.883	25.105	-0.054	0.052	-0.073	-0.105
-50.425	7.96	28.086	-50.292	7.833	27.512	-0.133	0.127	0.574	0.603
-54.339	11.668	22.161	-53.724	11.082	21.794	-0.615	0.586	0.368	0.925
-56.832	14.065	8.272	-56.391	13.644	8.161	-0.441	0.421	0.111	0.62
-62.571	-1.602	8.284	-61.797	-1.541	8.142	-0.774	-0.06	0.141	0.789
-59.106	-1.344	22.224	-58.107	-1.265	21.79	-0.999	-0.079	0.434	1.092
-53.542	-0.908	28.045	-53.376	-0.894	27.518	-0.166	-0.013	0.527	0.553
-47.894	-0.446	24.828	-47.628	-0.425	25.084	-0.266	-0.02	-0.256	-0.37
-45.39	-4.389	25.155	-45.432	-4.444	25.088	0.042	0.056	0.067	0.097
-49.067	-9.186	28.151	-48.945	-9.025	27.515	-0.123	-0.161	0.636	0.668
-52.231	-13.314	22.058	-51.831	-12.79	21.773	-0.399	-0.524	0.285	0.718

-54.4	-16.138	8.221		-54.082	-15.722	8.126		-0.318	-0.416	0.095		0.532
-38.363	-19.503	8.138		-38.377	-19.427	8.124		0.014	-0.076	0.014		0.078
-39.049	-15.897	21.8		-39.067	-15.802	21.758		0.018	-0.095	0.042		0.106
-39.905	-11.341	28.079		-39.94	-11.157	27.507		0.035	-0.183	0.572		0.602
-41.089	-4.952	25.622		-40.984	-5.475	25.108		-0.105	0.522	0.514		0.74
-40.233	19.81	8.191		-40.245	19.684	8.168		0.012	0.126	0.023		0.129
-40.562	16.263	21.895		-40.586	16.007	21.784		0.024	0.256	0.111		0.28
-40.993	11.503	28.046		-41.01	11.324	27.503		0.017	0.179	0.544		0.573
-41.555	5.158	25.544		-41.512	5.58	25.134		-0.043	-0.422	0.411		0.59
-39.06	3.9	25.81		-38.64	4.441	25.145		-0.42	-0.541	0.665		0.955
-35.058	9.146	27.916		-35.144	9.034	27.497		0.086	0.111	0.419		0.442
-32.368	12.671	21.722		-32.298	12.762	21.771		-0.07	-0.091	-0.05		-0.125
-30.199	15.52	8.122		-30.064	15.697	8.162		-0.135	-0.177	-0.041		-0.226
-24.024	6.739	8.061		-23.559	6.913	8.152		-0.465	-0.174	-0.091		-0.505
-27.393	5.472	21.585		-27.009	5.615	21.762		-0.384	-0.143	-0.177		-0.446
-31.299	4.01	27.805		-31.397	3.974	27.494		0.099	0.037	0.311		0.328
-37.651	1.656	26.014		-36.816	1.968	25.148		-0.835	-0.312	0.866		1.242
-37.485	-0.922	26.046		-36.574	-1.105	25.144		-0.911	0.183	0.902		1.295
-30.816	-2.326	27.811		-30.921	-2.304	27.495		0.104	-0.022	0.316		0.333
-26.758	-3.162	21.564		-26.326	-3.251	21.755		-0.432	0.089	-0.19		-0.48
-23.209	-3.883	8.048		-22.714	-3.984	8.14		-0.495	0.102	-0.092		-0.513
-27.983	-13.52	8.086		-27.809	-13.687	8.13		-0.174	0.167	-0.044		-0.245
-30.666	-10.955	21.64		-30.474	-11.139	21.754		-0.192	0.184	-0.115		-0.29
-33.769	-7.967	27.892		-33.864	-7.876	27.499		0.094	-0.09	0.393		0.414
-38.601	-3.276	25.927		-38.001	-3.84	25.13		-0.6	0.564	0.798		1.147
-42.061	5.25	25.477		-42.059	5.606	25.131		-0.002	-0.357	0.346		0.497
-42.124	11.553	28.057		-42.123	11.371	27.504		-0.001	0.182	0.553		0.582
-42.164	16.396	21.922		-42.163	16.076	21.784		-0.002	0.32	0.138		0.348
-42.182	19.958	8.203		-42.181	19.769	8.168		-0.001	0.189	0.034		0.192
-41.28	0.732	20.613		-40.695	1.265	20.127		-0.585	-0.533	0.486		0.929
-45.225	0.322	21.286		-44.851	0.283	21.538		-0.374	0.038	-0.251		-0.453
-41.113	-1.547	21.814		-40.692	-2.219	21.292		-0.421	0.672	0.522		0.95
45.078	-41.351	15.101		45.077	-41.355	15.129		0.001	0.004	-0.028		-0.029
42.406	-46.316	13.474		42.459	-46.217	13.269		-0.053	-0.099	0.206		0.234
40.161	-50.41	9.844		40.271	-50.209	9.642		-0.109	-0.201	0.202		0.306
38.688	-53.104	4.793		38.811	-52.877	4.691		-0.123	-0.226	0.102		0.277
31.934	-44.77	4.616		31.73	-44.85	4.703		0.204	0.08	-0.087		-0.236
34.633	-43.724	9.607		34.577	-43.746	9.661		0.056	0.022	-0.054		-0.081
38.844	-42.089	13.254		38.83	-42.095	13.283		0.015	0.006	-0.029		-0.033
44.004	-40.079	14.991		43.984	-40.087	15.135		0.02	0.008	-0.143		-0.145
43.961	-38.381	15.007		43.943	-38.375	15.139		0.019	-0.006	-0.132		-0.134

38.804	-36.632	13.099	38.702	-36.598	13.298	0.102	-0.034	-0.199	-0.226
34.654	-35.219	9.412	34.371	-35.124	9.677	0.283	-0.095	-0.266	-0.399
32.016	-34.317	4.495	31.475	-34.135	4.722	0.54	-0.182	-0.227	-0.614
38.54	-26.365	4.462	38.181	-25.772	4.739	0.36	-0.593	-0.277	-0.747
39.954	-28.694	9.375	39.77	-28.392	9.69	0.183	-0.301	-0.314	-0.472
42.21	-32.42	13.059	42.141	-32.307	13.305	0.069	-0.113	-0.245	-0.279
45.024	-37.054	15.03	45.016	-37.04	15.142	0.009	-0.014	-0.111	-0.112
46.693	-36.717	15.05	46.695	-36.704	15.14	-0.002	-0.013	-0.09	-0.091
47.525	-31.288	13.202	47.534	-31.235	13.301	-0.008	-0.053	-0.099	-0.113
48.198	-26.899	9.521	48.227	-26.715	9.687	-0.029	-0.184	-0.166	-0.249
48.631	-24.085	4.581	48.693	-23.689	4.742	-0.062	-0.396	-0.16	-0.432
38.687	-53.104	4.793	38.811	-52.878	4.69	-0.123	-0.227	0.102	0.278
40.163	-50.411	9.847	40.273	-50.209	9.643	-0.11	-0.202	0.204	0.307
42.407	-46.316	13.475	42.461	-46.217	13.269	-0.053	-0.099	0.206	0.235
45.079	-41.35	15.104	45.078	-41.354	15.13	0.001	0.004	-0.026	-0.026
47.468	-36.971	15.057	47.477	-36.962	15.138	-0.01	-0.009	-0.081	-0.083
50.178	-32.125	13.312	50.174	-32.132	13.296	0.004	0.008	0.016	0.018
52.301	-28.127	9.652	52.319	-28.1	9.682	-0.018	-0.028	-0.03	-0.044
53.697	-25.551	4.675	53.785	-25.416	4.739	-0.088	-0.134	-0.064	-0.173
61.228	-33.354	4.879	60.873	-33.491	4.727	0.355	0.137	0.152	0.41
58.297	-34.502	9.916	58.034	-34.603	9.666	0.263	0.101	0.25	0.376
53.931	-36.209	13.556	53.792	-36.262	13.282	0.139	0.053	0.274	0.312
48.645	-38.271	15.125	48.646	-38.27	15.133	-0.001	0	-0.008	-0.009
48.691	-39.983	15.159	48.686	-39.982	15.128	0.004	-0.002	0.031	0.031
54.139	-41.826	13.703	53.914	-41.749	13.267	0.225	-0.077	0.436	0.497
58.745	-43.378	10.134	58.222	-43.2	9.645	0.523	-0.178	0.489	0.737
61.834	-44.417	5.015	61.101	-44.168	4.708	0.733	-0.249	0.308	0.833
54.836	-53.173	5.007	54.426	-52.499	4.694	0.41	-0.674	0.313	0.849
53.139	-50.391	10.137	52.845	-49.908	9.637	0.294	-0.484	0.5	0.755
50.605	-46.234	13.697	50.481	-46.03	13.26	0.124	-0.204	0.437	0.497
47.619	-41.32	15.168	47.616	-41.314	15.126	0.003	-0.005	0.041	0.042
45.935	-41.65	15.123	45.934	-41.651	15.128	0	0.001	-0.005	-0.005
45.076	-47.279	13.581	45.101	-47.108	13.264	-0.026	-0.171	0.317	0.361
44.356	-51.984	9.977	44.413	-51.603	9.637	-0.057	-0.381	0.34	0.514
43.883	-55.079	4.878	43.955	-54.606	4.689	-0.071	-0.472	0.189	0.514
53.698	-25.549	4.677	53.785	-25.417	4.74	-0.087	-0.133	-0.063	-0.171
52.301	-28.126	9.654	52.319	-28.1	9.682	-0.017	-0.026	-0.028	-0.042
50.179	-32.125	13.311	50.175	-32.132	13.296	0.004	0.007	0.015	0.017
47.468	-36.97	15.057	47.478	-36.962	15.138	-0.01	-0.008	-0.082	-0.083
32.063	-49.812	0.428	32.116	-49.773	0.308	-0.052	-0.039	0.12	0.137
36.492	-54.235	0.405	36.538	-54.165	0.212	-0.046	-0.071	0.192	0.21

45.156	-56.839	0.809	45.172	-56.59	0.45	-0.016	-0.248	0.359	0.437
54.917	-54.737	1.108	54.7	-54.345	0.533	0.217	-0.392	0.576	0.73
61.537	-48.201	1.194	61.114	-47.949	0.645	0.423	-0.251	0.548	0.736
63.825	-39.446	1.123	63.44	-39.439	0.735	0.385	-0.007	0.387	0.546
5.61	29.759	-10.499	5.61	29.498	-10.577	0	0.262	0.078	0.273
2.243	29.757	-10.504	2.243	29.499	-10.581	0	0.258	0.077	0.269
2.234	26.82	0.083	2.234	26.343	-0.06	0	0.477	0.143	0.499
-1.124	29.763	-10.506	-1.124	29.5	-10.585	0	0.263	0.079	0.275
5.602	20.094	-12.711	5.602	19.995	-12.681	0	0.098	-0.03	-0.103
2.232	23.419	-2.241	2.232	23.151	-2.161	0	0.268	-0.08	-0.28
2.235	20.095	-12.713	2.235	19.995	-12.683	0	0.101	-0.03	-0.105
-1.132	20.069	-12.705	-1.132	19.995	-12.683	0	0.074	-0.022	-0.077
8.091	27.617	-10.595	8.061	27.617	-10.607	0.03	0	0.012	0.032
8.1	25.091	-10.593	8.062	25.091	-10.609	0.038	0	0.015	0.041
3.949	25.079	-0.047	3.853	25.079	-0.086	0.096	0	0.039	0.104
8.104	22.566	-10.595	8.063	22.566	-10.612	0.041	0	0.016	0.044
-4.725	27.633	-12.598	-4.606	27.633	-12.645	-0.119	0	0.048	0.128
-0.509	25.086	-2.084	-0.4	25.086	-2.128	-0.11	0	0.044	0.118
-4.73	25.108	-12.601	-4.608	25.108	-12.65	-0.122	0	0.049	0.131
-4.735	22.582	-12.604	-4.61	22.582	-12.654	-0.125	0	0.05	0.135
-9.006	5.035	-2.21	-9.183	5.134	-2.21	0.177	-0.099	0	0.202
-9.222	5.133	9.575	-9.193	5.117	9.575	-0.029	0.016	0	-0.033
-0.582	10.625	9.586	-0.576	10.505	9.586	-0.007	0.119	0	-0.12
-0.557	10.353	-2.199	-0.565	10.506	-2.199	0.008	-0.153	0	0.153
8.445	6.09	-2.197	8.533	6.154	-2.197	-0.088	-0.063	0	0.109
8.686	6.25	9.59	8.54	6.145	9.59	0.146	0.105	0	-0.18
10.148	-3.275	9.575	10.012	-3.231	9.575	0.136	-0.044	0	-0.143
9.885	-3.175	0.738	10.017	-3.217	0.738	-0.132	0.042	0	0.139
0.069	-10.455	0.724	0.069	-10.521	0.724	0	0.065	0	0.065
0.064	-10.59	9.562	0.063	-10.521	9.562	0	-0.07	0	-0.07
-10.037	-3.269	9.56	-10.004	-3.258	9.56	-0.033	-0.011	0	-0.035
-9.87	-3.2	0.722	-10.008	-3.245	0.722	0.137	0.045	0	0.145
10.812	-10.208	3.669	10.71	-10.112	3.669	0.102	-0.097	0	0.141
-11.196	-9.581	3.658	-11.191	-9.576	3.658	-0.005	-0.005	0	0.007
-14.712	1.983	0.73	-14.597	1.967	0.73	-0.115	0.016	0	0.116
-8.321	12.249	3.697	-8.276	12.184	3.697	-0.044	0.065	0	0.079
3.566	14.501	0.763	3.517	14.303	0.763	0.049	0.198	0	0.204
13.054	7.044	3.699	12.963	6.994	3.699	0.092	0.049	0	0.104
1.945	2.217	-16.706	1.945	2.217	-16.833	0	0	0.128	0.128
-3.727	3.893	-16.36	-3.727	3.893	-16.833	0	0	0.474	0.474
-3.816	-4.041	-16.314	-3.816	-4.041	-16.833	0	0	0.52	0.52

3.758	-3.902	-16.351	3.758	-3.902	-16.833	0	0	0.482	0.482
-0.285	0.27	-20.774	-0.285	0.27	-21.042	0	0	0.267	0.267
-9.335	-8.503	13.274	-9.335	-8.503	12.625	0	0	0.649	0.649
-11.961	3.556	13.26	-11.961	3.556	12.625	0	0	0.635	0.635
-0.879	12.026	13.155	-0.879	12.026	12.625	0	0	0.53	0.53
11.275	4.946	13.114	11.275	4.946	12.625	0	0	0.489	0.489
10.609	-6.994	13.149	10.609	-6.994	12.625	0	0	0.524	0.524
0.466	-12.792	13.222	0.466	-12.792	12.625	0	0	0.597	0.597
-0.417	-14.713	6.742	-0.418	-14.723	6.742	0	0.01	0	-0.01
7.154	-46.743	6.558	6.972	-46.743	6.558	0.182	0	0	0.182
7.178	-36.737	6.575	6.972	-36.737	6.575	0.206	0	0	0.206
7.166	-26.729	6.59	6.972	-26.729	6.59	0.194	0	0	0.194
7.143	-16.723	6.605	6.972	-16.723	6.605	0.17	0	0	0.17
4.576	-17.68	6.603	4.447	-17.68	6.603	0.129	0	0	-0.129
4.584	-27.403	6.588	4.447	-27.403	6.588	0.137	0	0	-0.137
4.579	-37.126	6.572	4.447	-37.126	6.572	0.132	0	0	-0.132
4.567	-46.847	6.558	4.447	-46.847	6.558	0.12	0	0	-0.12
-3.813	-46.859	9.498	-3.97	-46.859	9.498	0.156	0	0	0.156
-3.81	-37.174	9.513	-3.97	-37.174	9.513	0.16	0	0	0.16
-3.82	-27.489	9.528	-3.97	-27.489	9.528	0.15	0	0	0.15
-3.879	-17.806	9.542	-3.97	-17.806	9.542	0.09	0	0	0.09
-8.122	-16.051	3.651	-8.178	-16.051	3.651	0.056	0	0	-0.056
-8.112	-26.251	3.636	-8.178	-26.251	3.636	0.066	0	0	-0.066
-8.108	-36.452	3.619	-8.178	-36.452	3.619	0.07	0	0	-0.07
-8.05	-46.652	3.604	-8.178	-46.652	3.604	0.128	0	0	-0.128
-6.066	-50.767	6.992	-6.066	-50.5	6.992	0	-0.267	0	0.267
5.686	-50.664	10.234	5.686	-50.5	10.234	0	-0.164	0	0.164
5.684	-46.523	13.064	5.684	-46.523	12.625	0	0	0.439	0.439
5.713	-37.479	13.151	5.713	-37.479	12.625	0	0	0.526	0.526
5.631	-28.436	13.132	5.631	-28.436	12.625	0	0	0.507	0.507
5.871	-17.467	13.139	5.871	-17.467	12.625	0	0	0.514	0.514
-6.119	-16.899	13.289	-6.119	-16.899	12.625	0	0	0.664	0.664
-6.25	-27.303	13.245	-6.25	-27.303	12.625	0	0	0.62	0.62
-6.28	-36.12	13.212	-6.28	-36.12	12.625	0	0	0.587	0.587
-5.832	-47.873	13.21	-5.832	-47.873	12.625	0	0	0.585	0.585
62.971	-85.797	-0.842	62.971	-85.797	0	0	0	-0.842	-0.842
51.543	-86.155	-0.772	51.543	-86.155	0	0	0	-0.772	-0.772
30.797	-85.656	-0.511	30.797	-85.656	0	0	0	-0.511	-0.511
26.821	-77.934	-0.336	26.821	-77.934	0	0	0	-0.336	-0.336
40.004	-79.672	-0.573	40.004	-79.672	0	0	0	-0.573	-0.573
56.444	-76.298	-0.763	56.444	-76.298	0	0	0	-0.763	-0.763

61.102	-67.005	-0.73	61.102	-67.005	0	0	0	-0.73	-0.73
47.107	-70.243	-0.601	47.107	-70.243	0	0	0	-0.601	-0.601
37.592	-65.838	-0.399	37.592	-65.838	0	0	0	-0.399	-0.399
23.943	-65.496	-0.185	23.943	-65.496	0	0	0	-0.185	-0.185
19.994	-53.391	0.068	19.994	-53.391	0	0	0	0.068	0.068
15.232	-46.26	0.242	15.232	-46.26	0	0	0	0.242	0.242
23.642	-45.522	0.104	23.642	-45.522	0	0	0	0.104	0.104
14.892	-35.325	0.403	14.892	-35.325	0	0	0	0.403	0.403
15.767	-25.367	0.513	15.767	-25.367	0	0	0	0.513	0.513
25.676	-28.313	0.315	25.676	-28.313	0	0	0	0.315	0.315
33.666	-23.327	0.305	33.666	-23.327	0	0	0	0.305	0.305
61.755	-24.499	-0.269	61.755	-24.499	0	0	0	-0.269	-0.269
67.236	-35.026	0.156	66.907	-35.026	0	0.329	0	0.156	0.364
65.3	-54.995	-0.622	65.3	-54.995	0	0	0	-0.622	-0.622
69.007	-6.578	-0.149	69.007	-6.578	0	0	0	-0.149	-0.149
66.204	18.423	0.323	66.204	18.423	0	0	0	0.323	0.323
52.299	19.014	-0.161	52.299	19.014	0	0	0	-0.161	-0.161
38.421	18.779	-0.198	38.421	18.779	0	0	0	-0.198	-0.198
25.068	19.115	-0.077	25.068	19.115	0	0	0	-0.077	-0.077
27.18	28.573	-0.24	27.18	28.573	0	0	0	-0.24	-0.24
34.319	26.903	-0.313	34.319	26.903	0	0	0	-0.313	-0.313
46.06	25.956	-0.335	46.06	25.956	0	0	0	-0.335	-0.335
45.753	34.497	-0.354	45.753	34.497	0	0	0	-0.354	-0.354
29.785	39.427	-0.489	29.785	39.427	0	0	0	-0.489	-0.489
17.43	42.283	-0.56	17.43	42.283	0	0	0	-0.56	-0.56
7.187	39.421	-0.441	7.187	39.421	0	0	0	-0.441	-0.441
10.368	49.47	-0.621	10.368	49.47	0	0	0	-0.621	-0.621
23.058	52.419	-0.598	23.058	52.419	0	0	0	-0.598	-0.598
43.362	55.651	-0.387	43.362	55.651	0	0	0	-0.387	-0.387
66.552	54.295	-0.094	66.552	54.295	0	0	0	-0.094	-0.094
67.126	38.317	0.175	67.126	38.317	0	0	0	0.175	0.175
-12.097	40.914	-0.328	-12.097	40.914	0	0	0	-0.328	-0.328
-22.695	17.628	0.341	-22.695	17.628	0	0	0	0.341	0.341
-23.985	30.822	0.097	-23.985	30.822	0	0	0	0.097	0.097
-31.167	26.143	0.109	-31.167	26.143	0	0	0	0.109	0.109
-42.897	26.816	-0.005	-42.897	26.816	0	0	0	-0.005	-0.005
-50.385	30.678	-0.105	-50.385	30.678	0	0	0	-0.105	-0.105
-40.325	46.218	-0.283	-40.325	46.218	0	0	0	-0.283	-0.283
-47.44	54.783	-0.195	-47.44	54.783	0	0	0	-0.195	-0.195
-75.451	54.026	0.031	-75.451	54.026	0	0	0	0.031	0.031
-75.685	37.743	-0.09	-75.685	37.743	0	0	0	-0.09	-0.09

-74.486	19.583	-0.055	-74.486	19.583	0	0	0	-0.055	-0.055
-57.002	25.471	-0.157	-57.002	25.471	0	0	0	-0.157	-0.157
-66.055	12.171	-0.215	-66.055	12.171	0	0	0	-0.215	-0.215
-68.58	-0.885	-0.176	-68.58	-0.885	0	0	0	-0.176	-0.176
-76.944	-10.571	-0.07	-76.944	-10.571	0	0	0	-0.07	-0.07
-76.824	-29.046	-0.076	-76.824	-29.046	0	0	0	-0.076	-0.076
-62.554	-24.658	-0.002	-62.554	-24.658	0	0	0	-0.002	-0.002
-49.864	-21.709	0.097	-49.864	-21.709	0	0	0	0.097	0.097
-35.54	-26.424	0.328	-35.54	-26.424	0	0	0	0.328	0.328
-22.776	-17.954	0.533	-22.776	-17.954	0	0	0	0.533	0.533
-27.809	-36.894	0.376	-27.809	-36.894	0	0	0	0.376	0.376
-13.691	-50.99	0.366	-13.691	-50.99	0	0	0	0.366	0.366
-5.201	-60.053	0.166	-5.201	-60.053	0	0	0	0.166	0.166
-6.449	-70.853	-0.048	-6.449	-70.853	0	0	0	-0.048	-0.048
-7.809	-86.07	-0.164	-7.809	-86.07	0	0	0	-0.164	-0.164
-27.241	-90.647	-0.149	-27.241	-90.647	0	0	0	-0.149	-0.149
-40.931	-88.391	-0.171	-40.931	-88.391	0	0	0	-0.171	-0.171
-53.681	-81.966	-0.281	-53.681	-81.966	0	0	0	-0.281	-0.281
-62.898	-90.581	-0.218	-62.898	-90.581	0	0	0	-0.218	-0.218
-77.221	-85.867	-0.187	-77.221	-85.867	0	0	0	-0.187	-0.187
-75.543	-64.295	-0.188	-75.543	-64.295	0	0	0	-0.188	-0.188
-71.915	-44.03	-0.161	-71.915	-44.03	0	0	0	-0.161	-0.161
-65.772	-55.939	-0.166	-65.772	-55.939	0	0	0	-0.166	-0.166
-62.156	-65.734	-0.245	-62.156	-65.734	0	0	0	-0.245	-0.245
-50.431	-58.683	-0.008	-50.431	-58.683	0	0	0	-0.008	-0.008
-50.201	-72.739	-0.134	-50.201	-72.739	0	0	0	-0.134	-0.134
-14.032	-37.821	-16.476	-14.032	-37.821	-16.833	0	0	0.358	0.358
-14.407	-16.423	-16.449	-14.407	-16.423	-16.833	0	0	0.385	0.385
-13.558	16.253	-16.551	-13.558	16.253	-16.833	0	0	0.282	0.282
-13.375	29.46	-16.767	-13.375	29.46	-16.833	0	0	0.066	0.066
14.687	31.695	-17.08	14.687	31.695	-16.833	0	0	-0.247	-0.247
15.547	23.986	-16.889	15.547	23.986	-16.833	0	0	-0.056	-0.056
15.798	12.297	-16.726	15.798	12.297	-16.833	0	0	0.108	0.108
59.978	4.338	-16.926	59.978	4.338	-16.833	0	0	-0.093	-0.093
58.405	-9.932	-16.994	58.405	-9.932	-16.833	0	0	-0.161	-0.161
48.907	-15.216	-16.824	48.907	-15.216	-16.833	0	0	0.009	0.009
36.504	-9.609	-16.559	36.504	-9.609	-16.833	0	0	0.274	0.274
30.727	-17.627	-16.575	30.727	-17.627	-16.833	0	0	0.258	0.258
13.27	-15.092	-16.362	13.27	-15.092	-16.833	0	0	0.471	0.471
19.571	2.866	-3.989	19.571	2.866	-4.208	0	0	0.219	0.219
28.962	7.265	-4.223	28.962	7.265	-4.208	0	0	-0.014	-0.014

34.484	3.001	-4.198	34.484	3.001	-4.208	0	0	0.011	0.011
41.242	7.377	-4.323	41.242	7.377	-4.208	0	0	-0.115	-0.115
46.464	2.185	-4.275	46.464	2.185	-4.208	0	0	-0.067	-0.067
52.066	8.399	-4.364	52.066	8.399	-4.208	0	0	-0.155	-0.155
50.882	-4.057	-0.015	50.882	-4.03	0	0	-0.027	-0.015	-0.031
40.359	-3.912	0.043	40.359	-4.03	0	0	0.119	0.043	0.126
28.667	-2.786	0.286	28.667	-2.786	0	0	0	0.286	0.286
16.98	-1.967	0.234	16.98	-1.967	0	0	0	0.234	0.234
18.591	-9.299	1.97	18.591	-9.299	1.683	0	0	0.287	0.287
24.754	-6.47	1.938	24.754	-6.47	1.683	0	0	0.255	0.255
25.859	-14.779	1.395	25.859	-14.779	1.683	0	0	-0.288	-0.288
18.823	-12.035	-4.224	18.823	-12.447	-4.224	0	0.412	0	-0.412
24.779	-16.717	0.156	24.59	-16.655	0.156	0.189	-0.062	0	0.199
33.039	-3.496	-4.267	33.039	-4.03	-4.267	0	0.534	0	-0.534
40.062	-3.447	-3.509	40.062	-4.03	-3.509	0	0.583	0	-0.583
52.686	-3.471	-4.776	52.686	-4.03	-4.776	0	0.559	0	-0.559
55.196	0.135	-9.043	55.265	0.113	-9.043	-0.069	0.022	0	-0.072
56.506	7.921	-9.777	56.527	7.921	-9.777	-0.021	0	0	-0.021
59.531	12.296	-0.528	59.531	12.344	-0.632	0	-0.048	0.104	0.114
49.316	13.221	-1.488	49.316	13.159	-1.38	0	0.063	-0.108	-0.125
39.477	12.47	-1.445	39.477	12.362	-1.337	0	0.108	-0.108	-0.153

### 3D-Tol Data from CMM for Polyamide Titanium Casting

MEAS X	MEAS Y	MEAS Z	CAD X	CAD Y	CAD Z	DIF X	DIF Y	DIF Z	TOT DIF
53.824	58.338	-5.928	53.824	58.917	-5.928	0	-0.579	0	-0.579
37.278	58.29	-5.942	37.278	58.917	-5.942	0	-0.627	0	-0.627
20.733	58.294	-5.959	20.733	58.917	-5.959	0	-0.622	0	-0.622
4.189	58.318	-5.972	4.189	58.917	-5.972	0	-0.599	0	-0.599
-12.356	58.3	-5.989	-12.356	58.917	-5.989	0	-0.617	0	-0.617
-28.9	58.323	-6.005	-28.9	58.917	-6.005	0	-0.594	0	-0.594
-45.446	58.397	-6.021	-45.446	58.917	-6.021	0	-0.52	0	-0.52
-61.991	58.435	-6.036	-61.991	58.917	-6.036	0	-0.481	0	-0.481
-79.622	40.993	-6.026	-79.958	40.993	-6.026	0.337	0	0	-0.337
-79.564	24.448	-6.001	-79.958	24.448	-6.001	0.394	0	0	-0.394
-79.454	7.903	-5.976	-79.958	7.903	-5.976	0.504	0	0	-0.504
-79.394	-8.64	-5.952	-79.958	-8.64	-5.952	0.564	0	0	-0.564
-79.352	-25.186	-5.929	-79.958	-25.186	-5.929	0.606	0	0	-0.606
-79.42	-41.731	-5.904	-79.958	-41.731	-5.904	0.539	0	0	-0.539
-79.475	-58.275	-5.88	-79.958	-58.275	-5.88	0.483	0	0	-0.483

-79.532	-74.819	-5.856		-79.958	-74.819	-5.856		0.426	0	0		-0.426
-61.96	-92.114	-5.809		-61.96	-92.583	-5.809		0	0.469	0		-0.469
-45.415	-92.059	-5.793		-45.415	-92.583	-5.793		0	0.524	0		-0.524
-28.87	-91.888	-5.779		-28.87	-92.583	-5.779		0	0.696	0		-0.696
-12.325	-91.93	-5.762		-12.325	-92.583	-5.762		0	0.653	0		-0.653
4.218	-91.896	-5.748		4.218	-92.583	-5.748		0	0.687	0		-0.687
20.764	-91.929	-5.732		20.764	-92.583	-5.732		0	0.655	0		-0.655
37.308	-91.996	-5.716		37.308	-92.583	-5.716		0	0.587	0		-0.587
53.853	-92.094	-5.7		53.853	-92.583	-5.7		0	0.49	0		-0.49
70.753	-74.792	-5.711		71.542	-74.792	-5.711		-0.789	0	0		-0.789
70.681	-58.246	-5.735		71.542	-58.246	-5.735		-0.861	0	0		-0.861
70.646	-41.702	-5.759		71.542	-41.702	-5.759		-0.896	0	0		-0.896
70.58	-25.157	-5.783		71.542	-25.157	-5.783		-0.962	0	0		-0.962
70.505	-8.612	-5.807		71.542	-8.612	-5.807		-1.037	0	0		-1.037
70.454	7.932	-5.831		71.542	7.932	-5.831		-1.088	0	0		-1.088
70.578	24.477	-5.855		71.542	24.477	-5.855		-0.964	0	0		-0.964
70.683	41.021	-5.88		71.542	41.021	-5.88		-0.859	0	0		-0.859
-69.745	43.71	8.148		-69.745	43.71	8.417		0	0	-0.268		-0.268
-64.694	43.712	8.067		-64.694	43.712	8.417		0	0	-0.35		-0.35
-64.696	48.762	8.119		-64.696	48.762	8.417		0	0	-0.298		-0.298
-69.746	48.761	8.142		-69.746	48.761	8.417		0	0	-0.275		-0.275
-67.614	46.356	8.122		-67.614	46.356	8.417		0	0	-0.295		-0.295
-71.71	43.705	6.603		-71.542	43.705	6.603		-0.169	0	0		0.169
-71.686	48.757	6.595		-71.542	48.757	6.595		-0.145	0	0		0.145
-69.743	50.496	6.593		-69.743	50.5	6.593		0	-0.004	0		-0.004
-64.693	50.365	6.6		-64.693	50.5	6.6		0	-0.135	0		-0.135
-64.69	42.019	7.597		-64.69	42.083	8.417		0	-0.065	-0.82		0.822
-69.741	42.753	6.612		-69.741	42.083	6.612		0	0.67	0		-0.67
-63.071	49.741	6.608		-63.125	50.5	6.608		0.054	-0.759	0		0.761
-63.157	42.723	6.616		-63.157	42.083	6.616		0	0.64	0		0.64
-64.68	-14.369	4.095		-64.68	-14.369	4.208		0	0	-0.113		-0.113
-69.731	-14.37	4.039		-69.731	-14.37	4.208		0	0	-0.169		-0.169
-69.729	-19.418	4.122		-69.729	-19.418	4.208		0	0	-0.086		-0.086
-64.679	-19.417	4.132		-64.679	-19.417	4.208		0	0	-0.076		-0.076
-67.85	-16.796	4.034		-67.85	-16.796	4.208		0	0	-0.174		-0.174
-69.728	-12.518	4.078		-69.728	-12.625	4.208		0	0.107	-0.13		0.169
-64.678	-12.566	4.126		-64.678	-12.625	4.208		0	0.059	-0.083		0.102
-63.145	-14.371	4.286		-63.125	-14.371	4.208		-0.02	0	0.077		-0.08
-63.147	-19.421	4.294		-63.125	-19.421	4.208		-0.022	0	0.086		-0.089
-64.675	-21.106	4.124		-64.675	-21.042	4.208		0	-0.065	-0.084		0.106
-69.725	-21.131	4.099		-69.725	-21.042	4.208		0	-0.089	-0.109		0.141

-71.775	-19.425	3.327	-71.542	-19.425	3.327	-0.233	0	0	0.233
-71.726	-14.374	3.321	-71.542	-14.374	3.321	-0.185	0	0	0.185
-64.672	-77.487	8.292	-64.672	-77.487	8.417	0	0	-0.125	-0.125
-69.723	-77.489	8.311	-69.723	-77.489	8.417	0	0	-0.105	-0.105
-69.72	-82.537	8.319	-69.72	-82.537	8.417	0	0	-0.097	-0.097
-64.671	-82.537	8.304	-64.671	-82.537	8.417	0	0	-0.113	-0.113
-69.719	-75.659	7.754	-69.719	-75.75	8.417	0	0.091	-0.663	0.669
-63.685	-75.736	6.785	-63.125	-75.75	6.785	-0.56	0.014	0	0.561
-63.109	-77.491	7.775	-63.125	-77.491	8.417	0.016	0	-0.642	0.642
-63.069	-82.542	7.782	-63.125	-82.542	8.417	0.056	0	-0.635	0.638
-64.666	-84.056	6.8	-64.666	-84.167	6.8	0	0.11	0	-0.11
-69.717	-84.135	6.797	-69.717	-84.167	6.797	0	0.032	0	-0.032
-71.608	-82.544	6.786	-71.542	-82.544	6.786	-0.066	0	0	0.066
-71.463	-77.493	6.78	-71.542	-77.493	6.78	0.079	0	0	-0.079
-2.408	43.718	4.33	-2.408	43.718	4.208	0	0	0.122	0.122
2.644	43.72	4.371	2.644	43.72	4.208	0	0	0.163	0.163
2.641	48.769	4.352	2.641	48.769	4.208	0	0	0.143	0.143
-2.409	48.767	4.311	-2.409	48.767	4.208	0	0	0.103	0.103
-0.569	46.753	4.356	-0.569	46.753	4.208	0	0	0.148	0.148
-4.305	43.709	2.038	-4.208	43.709	2.038	-0.097	0	0	0.097
-4.258	48.762	2.031	-4.208	48.762	2.031	-0.05	0	0	0.05
2.647	42.487	2.049	2.647	42.083	2.049	0	0.404	0	-0.404
-2.403	42.514	2.047	-2.403	42.083	2.047	0	0.431	0	-0.431
3.774	48.764	2.041	4.208	48.764	2.041	-0.434	0	0	-0.434
3.753	43.714	2.05	4.208	43.714	2.05	-0.456	0	0	-0.456
-2.405	50.585	2.028	-2.405	50.5	2.028	0	0.085	0	0.085
2.645	50.574	2.034	2.645	50.5	2.034	0	0.074	0	0.074
-64.666	36.154	-0.429	-64.756	36.244	0	0.09	-0.09	-0.429	0.447
-53.949	46.866	-0.434	-54.042	46.958	0	0.092	-0.092	-0.434	0.453
-46.82	46.843	-1.37	-46.831	46.831	-1.37	0.012	0.012	0	-0.016
-36.096	36.139	-1.344	-36.118	36.118	-1.344	0.021	0.021	0	-0.03
-41.007	28.855	-1.341	-40.882	28.979	-1.341	-0.125	-0.125	0	-0.176
-48.176	35.969	-1.358	-48.024	36.121	-1.358	-0.152	-0.152	0	-0.215
-35.923	29.822	-1.722	-35.696	29.595	-1.722	-0.227	0.227	0	0.321
-54.32	35.333	-1.367	-54.042	35.055	-1.367	-0.278	0.278	0	0.393
-59.111	30.6	-1.36	-58.804	30.293	-1.36	-0.307	0.307	0	0.434
-65.451	29.366	-1.267	-65.263	29.554	-1.267	-0.188	-0.188	0	-0.266
-61.268	33.489	-4.139	-61.268	33.489	-4.208	0	0	0.069	0.069
-56.701	38.244	-4.12	-56.701	38.244	-4.208	0	0	0.088	0.088
-50.206	43.648	-4.141	-50.206	43.648	-4.208	0	0	0.067	0.067
-44.645	38.601	-4.075	-44.645	38.601	-4.208	0	0	0.133	0.133

-39.969	33.795	-4.048	-39.969	33.795	-4.208	0	0	0.161	0.161
49.778	42.404	5.881	49.778	42.083	5.881	0	0.321	0	-0.321
43.043	42.443	5.875	43.043	42.083	5.875	0	0.359	0	-0.359
54.838	30.261	5.901	54.708	30.261	5.901	0.13	0	0	-0.13
54.842	36.996	5.89	54.708	36.996	5.89	0.134	0	0	-0.134
58.92	25.542	5.42	58.92	25.25	5.42	0	0.292	0	-0.292
62.671	30.264	5.91	63.125	30.264	5.91	-0.454	0	0	-0.454
62.714	37.84	5.901	63.125	37.84	5.901	-0.411	0	0	-0.411
62.753	45.414	5.89	63.125	45.414	5.89	-0.372	0	0	-0.372
58.191	50.256	5.872	58.191	50.5	5.872	0	-0.244	0	-0.244
50.614	50.273	5.864	50.614	50.5	5.864	0	-0.227	0	-0.227
43.041	50.278	5.858	43.041	50.5	5.858	0	-0.222	0	-0.222
38.084	46.2	5.143	37.875	46.2	5.143	0.209	0	0	-0.209
43.288	46.376	8.37	43.288	46.376	8.417	0	0	-0.047	-0.047
50.519	46.088	8.371	50.519	46.088	8.417	0	0	-0.046	-0.046
58.491	45.758	8.375	58.491	45.758	8.417	0	0	-0.041	-0.041
59.233	37.493	8.274	59.233	37.493	8.417	0	0	-0.143	-0.143
59.111	30.648	8.171	59.111	30.648	8.417	0	0	-0.246	-0.246
-30.795	49.291	16.602	-30.795	48.817	16.876	0	0.474	-0.274	-0.547
-30.789	46.205	11.679	-30.789	45.914	11.847	0	0.291	-0.168	-0.336
-30.785	43.296	6.659	-30.785	43.013	6.823	0	0.283	-0.163	-0.327
-30.778	40.395	1.634	-30.778	40.112	1.798	0	0.283	-0.163	-0.327
-26.992	40.396	1.638	-26.992	40.114	1.801	0	0.283	-0.163	-0.326
-26.998	43.321	6.65	-26.998	43.015	6.827	0	0.305	-0.176	-0.353
-27.004	46.194	11.69	-27.004	45.916	11.851	0	0.279	-0.161	-0.322
-27.008	49.206	16.652	-27.008	48.817	16.876	0	0.388	-0.224	-0.448
-23.219	49.159	16.682	-23.219	48.819	16.879	0	0.34	-0.196	-0.393
-23.214	46.173	11.706	-23.214	45.918	11.854	0	0.256	-0.148	-0.295
-23.209	43.292	6.671	-23.209	43.017	6.83	0	0.275	-0.159	-0.317
-23.204	40.387	1.644	-23.204	40.114	1.802	0	0.273	-0.158	-0.315
-16.893	45.726	1.71	-16.893	45.388	1.801	0	0.339	-0.091	-0.351
-16.901	47.7	9.258	-16.901	47.407	9.336	0	0.293	-0.079	-0.303
-16.909	49.805	16.774	-16.909	49.427	16.875	0	0.378	-0.101	-0.392
-11.857	49.76	16.791	-11.857	49.428	16.88	0	0.332	-0.089	-0.343
-11.85	47.709	9.259	-11.85	47.408	9.34	0	0.301	-0.081	-0.312
-11.842	45.665	1.73	-11.842	45.389	1.804	0	0.276	-0.074	-0.286
-8.947	49.57	7.45	-8.178	49.57	7.45	-0.769	0	0	-0.769
-30.796	51.148	15.036	-30.796	50.988	14.993	0	0.16	0.043	0.166
-30.793	52.668	9.383	-30.793	52.503	9.338	0	0.165	0.044	0.171
-30.79	54.196	3.732	-30.79	54.018	3.684	0	0.178	0.048	0.184
-24.053	54.103	3.713	-24.053	54.016	3.69	0	0.087	0.023	0.09

-24.058	52.61	9.372	-24.058	52.502	9.343	0	0.108	0.029	0.112
-24.064	51.124	15.035	-24.064	50.986	14.998	0	0.137	0.037	0.142
-17.328	51.057	15.023	-17.328	50.985	15.004	0	0.072	0.019	0.075
-17.328	52.583	9.371	-17.328	52.5	9.349	0	0.083	0.022	0.085
-17.322	54.073	3.711	-17.322	54.015	3.695	0	0.058	0.015	0.06
-10.586	54.092	3.723	-10.586	54.013	3.702	0	0.078	0.021	0.081
-10.591	52.543	9.366	-10.591	52.499	9.355	0	0.044	0.012	0.046
-10.596	50.956	15.003	-10.596	50.983	15.01	0	-0.027	-0.007	-0.028
-33.264	48.91	9.57	-33.428	48.91	9.57	0.164	0	0	-0.164
5.042	-63.155	18.982	5.083	-63.155	18.971	-0.042	0	0.011	0.043
3.244	-63.165	11.887	3.189	-63.165	11.902	0.055	0	-0.015	-0.057
1.34	-63.175	4.824	1.296	-63.175	4.836	0.044	0	-0.012	-0.046
1.362	-69.909	4.828	1.298	-69.909	4.845	0.063	0	-0.017	-0.066
3.143	-69.897	11.926	3.192	-69.897	11.913	-0.05	0	0.013	0.051
5.012	-69.887	18.999	5.085	-69.887	18.979	-0.073	0	0.02	0.076
4.978	-76.622	19.018	5.088	-76.622	18.989	-0.11	0	0.029	0.114
3.142	-76.632	11.934	3.194	-76.632	11.92	-0.052	0	0.014	0.053
1.364	-76.642	4.835	1.3	-76.642	4.852	0.064	0	-0.017	-0.067
1.289	-83.376	4.864	1.302	-83.376	4.861	-0.013	0	0.003	0.013
3.114	-83.364	11.955	3.197	-83.364	11.932	-0.083	0	0.022	0.086
5.097	-83.353	18.998	5.091	-83.353	19	0.006	0	-0.002	-0.007
7.598	-85.493	10.499	7.598	-85.85	10.499	0	0.357	0	-0.357
7.277	-83.348	21.032	7.648	-83.348	21.246	-0.371	0	-0.214	-0.428
12.755	-83.362	11.633	13.087	-83.362	11.825	-0.333	0	-0.192	-0.384
18.35	-83.374	2.297	18.528	-83.374	2.4	-0.178	0	-0.103	-0.206
18.385	-75.798	2.308	18.532	-75.798	2.393	-0.147	0	-0.085	-0.17
12.781	-75.786	11.638	13.091	-75.786	11.818	-0.31	0	-0.179	-0.359
7.239	-75.774	21	7.652	-75.774	21.239	-0.413	0	-0.239	-0.477
6.551	-69.46	21.176	6.924	-69.46	21.276	-0.373	0	-0.1	-0.386
9.125	-69.474	11.765	9.449	-69.474	11.852	-0.324	0	-0.087	-0.335
11.747	-69.487	2.368	11.974	-69.487	2.429	-0.227	0	-0.061	-0.235
11.749	-64.437	2.362	11.976	-64.437	2.423	-0.227	0	-0.061	-0.235
9.16	-64.424	11.768	9.451	-64.424	11.846	-0.291	0	-0.078	-0.301
6.623	-64.41	21.187	6.926	-64.41	21.268	-0.303	0	-0.081	-0.314
6.576	-61.416	11.206	6.576	-60.6	11.206	0	-0.816	0	-0.816
-30.378	-50.586	-5.3	-30.385	-50.469	-5.428	0.006	-0.117	0.128	0.173
-30.083	-55.188	-7.672	-30.088	-55.094	-7.85	0.005	-0.094	0.178	0.202
-29.845	-58.681	-11.516	-29.851	-58.546	-11.587	0.006	-0.135	0.071	0.152
-29.653	-61.623	-15.798	-29.655	-61.564	-15.88	0.002	-0.059	0.082	0.101
-33.689	-63.481	-15.947	-33.678	-63.491	-15.926	-0.011	0.01	-0.021	-0.025
-36	-61.41	-11.645	-35.965	-61.441	-11.621	-0.034	0.031	-0.024	-0.052

-38.492	-59.176	-7.829	-38.512	-59.157	-7.88	0.02	-0.018	0.051	0.057
-41.977	-56.057	-5.49	-41.968	-56.066	-5.476	-0.009	0.008	-0.014	-0.019
-46.429	-68.199	-5.611	-46.292	-68.192	-5.459	-0.137	-0.007	-0.152	-0.205
-41.689	-67.981	-7.942	-41.652	-67.979	-7.873	-0.037	-0.002	-0.068	-0.078
-38.505	-67.846	-11.754	-38.229	-67.831	-11.609	-0.276	-0.016	-0.145	-0.312
-35.274	-67.703	-16.054	-35.174	-67.697	-15.912	-0.1	-0.006	-0.142	-0.174
-33.361	-71.824	-16.026	-33.275	-71.725	-15.847	-0.086	-0.099	-0.179	-0.222
-35.534	-74.151	-11.729	-35.32	-73.912	-11.559	-0.213	-0.24	-0.169	-0.363
-37.742	-76.507	-7.97	-37.694	-76.453	-7.833	-0.048	-0.053	-0.137	-0.155
-41.001	-80.014	-5.629	-40.852	-79.851	-5.393	-0.149	-0.163	-0.236	-0.323
-29.602	-67.453	-16.83	-29.599	-67.451	-16.859	-0.003	-0.002	0.029	0.029
-26.533	-62.394	-15.666	-26.474	-62.296	-15.82	-0.058	-0.098	0.153	0.191
-25.154	-59.854	-11.447	-25.06	-59.691	-11.547	-0.094	-0.163	0.1	0.213
-23.442	-56.674	-7.656	-23.401	-56.602	-7.815	-0.041	-0.072	0.159	0.179
-21.241	-52.637	-5.23	-21.181	-52.529	-5.36	-0.061	-0.108	0.13	0.18
-13.118	-62.654	-5.23	-13.071	-62.641	-5.278	-0.046	-0.013	0.048	0.068
-17.587	-63.968	-7.632	-17.519	-63.949	-7.77	-0.067	-0.019	0.138	0.154
-21.086	-65.008	-11.409	-20.934	-64.966	-11.492	-0.151	-0.042	0.083	0.178
-23.793	-65.814	-15.626	-23.705	-65.791	-15.742	-0.088	-0.024	0.116	0.148
-24.219	-70.192	-15.683	-24.198	-70.204	-15.713	-0.021	0.011	0.03	0.038
-21.696	-71.566	-11.456	-21.679	-71.575	-11.466	-0.017	0.009	0.01	0.022
-18.548	-73.282	-7.712	-18.53	-73.291	-7.751	-0.017	0.009	0.039	0.044
-14.44	-75.523	-5.272	-14.464	-75.51	-5.245	0.025	-0.013	-0.028	-0.039
-24.502	-83.761	-5.4	-24.536	-83.648	-5.282	0.034	-0.113	-0.118	-0.167
-25.839	-79.212	-7.788	-25.841	-79.204	-7.77	0.003	-0.008	-0.017	-0.02
-26.794	-75.919	-11.559	-26.835	-75.786	-11.485	0.041	-0.133	-0.074	-0.158
-27.63	-73.063	-15.833	-27.65	-73	-15.748	0.02	-0.063	-0.085	-0.108
-32.348	-72.539	-15.967	-32.262	-72.466	-15.825	-0.086	-0.074	-0.142	-0.182
-33.878	-75.263	-11.675	-33.687	-75.075	-11.54	-0.19	-0.188	-0.136	-0.3
-35.406	-78.177	-7.91	-35.365	-78.145	-7.816	-0.041	-0.033	-0.094	-0.108
-37.739	-82.35	-5.569	-37.587	-82.213	-5.366	-0.152	-0.137	-0.203	-0.288
-25.259	-86.411	-0.638	-25.279	-86.321	-0.518	0.02	-0.09	-0.121	-0.152
-12.954	-77.218	-0.639	-12.932	-77.231	-0.667	-0.022	0.013	0.028	0.038
-11.048	-61.869	-0.576	-10.979	-61.848	-0.656	-0.069	-0.021	0.08	0.108
-16.037	-53.677	-0.542	-15.956	-53.594	-0.668	-0.081	-0.083	0.126	0.171
-25.674	-48.445	-0.407	-25.65	-48.323	-0.561	-0.024	-0.122	0.154	0.198
-47.411	-37.913	18.749	-47.16	-37.8	18.908	-0.251	-0.113	-0.159	-0.318
-44.079	-36.352	12.454	-43.86	-36.251	12.594	-0.219	-0.101	-0.139	-0.279
-40.788	-34.805	6.136	-40.561	-34.7	6.281	-0.227	-0.105	-0.144	-0.289
-39.989	-41.302	6.121	-39.736	-41.35	6.27	-0.253	0.048	-0.149	-0.298
-43.556	-40.623	12.443	-43.317	-40.669	12.584	-0.24	0.046	-0.141	-0.282

-47.179	-39.935	18.734	-46.898	-39.989	18.899	-0.281	0.054	-0.165	-0.33
-48.091	-41.777	18.785	-47.946	-41.926	18.905	-0.145	0.149	-0.12	-0.24
-45.518	-44.498	12.529	-45.443	-44.576	12.592	-0.075	0.078	-0.063	-0.125
-43.013	-47.147	6.217	-42.939	-47.225	6.279	-0.074	0.078	-0.062	-0.124
-48.976	-50.192	6.339	-48.984	-50.133	6.304	0.008	-0.059	0.034	0.069
-49.452	-46.582	12.655	-49.461	-46.519	12.618	0.009	-0.063	0.037	0.073
-49.938	-42.935	18.947	-49.942	-42.906	18.93	0.005	-0.029	0.017	0.034
-52.211	-42.638	19.03	-52.156	-42.532	18.961	-0.055	-0.107	0.069	0.138
-53.986	-45.933	12.775	-53.884	-45.74	12.649	-0.101	-0.193	0.126	0.252
-55.721	-49.132	6.462	-55.621	-48.943	6.338	-0.1	-0.189	0.123	0.246
-51.915	-40.028	22.864	-51.772	-39.955	22.772	-0.143	-0.074	0.093	0.186
-57.273	-42.604	12.832	-57.026	-42.483	12.674	-0.246	-0.12	0.158	0.317
-62.572	-45.138	2.756	-62.287	-45	2.573	-0.285	-0.138	0.183	0.366
-63.589	-36.875	2.713	-63.368	-36.916	2.583	-0.221	0.041	0.13	0.26
-57.87	-37.936	12.825	-57.633	-37.98	12.686	-0.237	0.044	0.139	0.279
-51.996	-39.025	22.839	-51.901	-39.043	22.784	-0.095	0.017	0.056	0.112
-51.407	-38.282	22.74	-51.45	-38.234	22.777	0.043	-0.048	-0.037	-0.074
-55.532	-33.897	12.748	-55.447	-33.988	12.677	-0.085	0.091	0.072	0.143
-59.531	-29.666	2.641	-59.453	-29.749	2.576	-0.078	0.083	0.066	0.131
-52.061	-26.294	2.548	-52.062	-26.288	2.551	0.001	-0.006	-0.003	-0.007
-51.327	-32.071	12.655	-51.327	-32.074	12.653	0	0.003	0.002	0.004
-50.006	-37.935	22.942	-49.849	-38.108	22.897	-0.158	0.173	0.044	0.238
-50.034	-38.279	22.527	-49.8	-38.02	22.723	-0.234	-0.259	-0.196	-0.4
-47.121	-33.041	12.517	-47.004	-32.901	12.62	-0.117	-0.14	-0.103	-0.21
-44.324	-27.916	2.424	-44.209	-27.784	2.522	-0.115	-0.131	-0.098	-0.2
-46.195	3.965	24.991	-46.105	3.879	25.112	-0.09	0.086	-0.12	-0.173
-50.299	7.826	27.725	-50.256	7.786	27.53	-0.043	0.041	0.195	0.204
-53.958	11.274	22.006	-53.718	11.045	21.862	-0.24	0.228	0.145	0.362
-56.685	13.836	8.289	-56.426	13.591	8.224	-0.259	0.245	0.065	0.362
-62.12	-1.693	8.304	-61.769	-1.663	8.24	-0.35	-0.03	0.064	0.358
-58.4	-1.369	22.024	-58.064	-1.341	21.876	-0.336	-0.028	0.148	0.368
-53.387	-0.953	27.76	-53.32	-0.947	27.534	-0.068	-0.006	0.226	0.236
-47.777	-0.504	24.984	-47.647	-0.493	25.11	-0.13	-0.012	-0.126	-0.181
-45.412	-4.56	25.115	-45.396	-4.537	25.143	-0.017	-0.023	-0.028	-0.04
-48.911	-9.101	27.734	-48.871	-9.049	27.523	-0.039	-0.053	0.212	0.222
-51.847	-12.967	21.958	-51.731	-12.812	21.873	-0.117	-0.155	0.085	0.212
-54.054	-15.89	8.28	-53.969	-15.778	8.254	-0.085	-0.112	0.026	0.143
-38.349	-19.263	8.231	-38.324	-19.392	8.255	-0.025	0.129	-0.024	-0.134
-39.034	-15.683	21.823	-39.02	-15.751	21.853	-0.013	0.069	-0.031	-0.076
-39.879	-11.192	27.624	-39.887	-11.153	27.505	0.008	-0.038	0.119	0.126
-40.948	-5.415	25.313	-40.922	-5.541	25.187	-0.026	0.126	0.126	0.18

-40.202	19.736	8.228	-40.208	19.671	8.217	0.006	0.064	0.012	0.066
-40.544	16.066	21.878	-40.552	15.979	21.84	0.008	0.087	0.038	0.095
-40.968	11.336	27.676	-40.973	11.284	27.514	0.005	0.051	0.162	0.17
-41.462	5.572	25.17	-41.46	5.591	25.151	-0.002	-0.019	0.019	0.027
-38.65	4.312	25.319	-38.561	4.423	25.18	-0.089	-0.111	0.139	0.199
-35.095	9.016	27.588	-35.112	8.993	27.501	0.018	0.023	0.087	0.092
-32.311	12.659	21.8	-32.271	12.71	21.828	-0.039	-0.051	-0.028	-0.07
-30.1	15.521	8.192	-30.007	15.64	8.22	-0.092	-0.12	-0.028	-0.154
-23.814	6.728	8.173	-23.542	6.828	8.226	-0.273	-0.1	-0.053	-0.295
-27.23	5.478	21.724	-27.016	5.557	21.823	-0.214	-0.079	-0.099	-0.249
-31.376	3.937	27.492	-31.376	3.937	27.491	0	0	0	0
-36.926	1.853	25.398	-36.74	1.919	25.204	-0.186	-0.067	0.194	0.277
-36.753	-1.113	25.45	-36.517	-1.162	25.213	-0.236	0.049	0.237	0.338
-30.903	-2.326	27.488	-30.903	-2.326	27.488	0	0	0	0
-26.669	-3.213	21.689	-26.363	-3.277	21.825	-0.306	0.064	-0.136	-0.341
-23.098	-3.97	8.171	-22.745	-4.044	8.237	-0.353	0.074	-0.066	-0.367
-28.039	-13.474	8.194	-27.828	-13.677	8.247	-0.211	0.202	-0.053	-0.297
-30.666	-10.937	21.734	-30.491	-11.104	21.839	-0.174	0.167	-0.105	-0.264
-33.828	-7.885	27.525	-33.836	-7.877	27.493	0.008	-0.008	0.033	0.034
-38.101	-3.754	25.417	-37.948	-3.898	25.21	-0.153	0.144	0.207	0.295
-42.014	5.623	25.147	-42.014	5.622	25.148	0	0.001	-0.001	-0.001
-42.089	11.389	27.695	-42.089	11.332	27.516	0	0.057	0.179	0.187
-42.129	16.181	21.9	-42.129	16.051	21.843	0	0.131	0.057	0.143
-42.152	19.882	8.238	-42.152	19.761	8.216	0	0.121	0.022	0.123
-40.814	1.068	20.355	-40.614	1.236	20.194	-0.2	-0.168	0.161	0.307
-45.064	0.229	21.457	-44.884	0.215	21.578	-0.18	0.014	-0.121	-0.218
-40.825	-2.064	21.57	-40.685	-2.293	21.393	-0.14	0.229	0.177	0.321
44.996	-41.105	14.581	45.125	-41.269	15.144	-0.128	0.164	-0.563	-0.6
42.52	-45.922	13.086	42.501	-46.071	13.349	0.019	0.149	-0.263	-0.303
40.364	-49.901	9.658	40.319	-50.065	9.809	0.045	0.164	-0.151	-0.228
38.876	-52.662	4.881	38.836	-52.78	4.932	0.04	0.118	-0.051	-0.134
31.968	-44.823	4.889	31.844	-44.872	4.944	0.124	0.049	-0.055	-0.145
34.946	-43.649	9.635	34.741	-43.731	9.837	0.205	0.082	-0.202	-0.299
39.174	-41.988	13.028	39.003	-42.057	13.377	0.171	0.068	-0.349	-0.394
44.918	-40.522	15.332	45.397	-40.769	15.217	-0.479	0.247	0.114	0.551
44.15	-38.395	14.562	44.071	-38.367	15.156	0.079	-0.027	-0.595	-0.6
39.041	-36.675	13.027	38.864	-36.615	13.382	0.177	-0.06	-0.355	-0.401
34.723	-35.22	9.643	34.518	-35.151	9.841	0.205	-0.069	-0.198	-0.293
31.728	-34.218	4.867	31.561	-34.161	4.941	0.168	-0.057	-0.074	-0.192
38.387	-25.99	4.834	38.275	-25.803	4.925	0.112	-0.187	-0.09	-0.236
39.983	-28.616	9.656	39.89	-28.46	9.822	0.094	-0.156	-0.166	-0.247

42.352	-32.499	13.07	42.272	-32.364	13.367	0.08	-0.135	-0.297	-0.336
45.168	-37.123	14.553	45.126	-37.048	15.151	0.042	-0.075	-0.597	-0.604
46.766	-36.804	14.543	46.784	-36.717	15.14	-0.018	-0.087	-0.596	-0.603
47.579	-31.466	13.037	47.605	-31.309	13.335	-0.026	-0.157	-0.298	-0.338
48.262	-26.994	9.62	48.291	-26.814	9.785	-0.029	-0.18	-0.165	-0.246
48.734	-23.934	4.832	48.761	-23.766	4.902	-0.027	-0.167	-0.07	-0.183
38.876	-52.661	4.882	38.836	-52.779	4.933	0.04	0.118	-0.051	-0.135
40.364	-49.9	9.658	40.319	-50.065	9.809	0.045	0.165	-0.151	-0.228
42.52	-45.919	13.086	42.502	-46.069	13.35	0.018	0.15	-0.264	-0.304
44.997	-41.105	14.58	45.125	-41.269	15.144	-0.127	0.163	-0.564	-0.601
47.295	-36.922	14.578	47.493	-36.934	15.134	-0.198	0.013	-0.556	-0.59
49.984	-32.249	13.035	50.109	-32.144	13.319	-0.125	-0.105	-0.283	-0.327
52.16	-28.303	9.608	52.282	-28.168	9.768	-0.122	-0.136	-0.161	-0.243
53.644	-25.607	4.821	53.755	-25.471	4.892	-0.111	-0.136	-0.071	-0.189
60.585	-33.629	4.775	60.824	-33.537	4.88	-0.239	-0.092	-0.105	-0.277
58.604	-34.834	9.266	58.635	-34.892	9.119	-0.03	0.058	0.146	0.16
53.581	-36.353	12.9	53.779	-36.278	13.292	-0.198	-0.076	-0.392	-0.445
48.621	-38.293	14.5	48.711	-38.26	15.123	-0.091	-0.033	-0.624	-0.631
48.661	-39.915	14.515	48.751	-39.945	15.121	-0.089	0.03	-0.605	-0.613
53.702	-41.621	12.9	53.9	-41.687	13.285	-0.198	0.066	-0.384	-0.437
57.908	-43.038	9.489	58.165	-43.125	9.733	-0.257	0.086	-0.243	-0.364
60.881	-44.047	4.812	61.048	-44.103	4.884	-0.167	0.056	-0.072	-0.19
54.398	-52.266	4.848	54.466	-52.377	4.901	-0.068	0.111	-0.054	-0.141
52.79	-49.621	9.606	52.878	-49.763	9.756	-0.088	0.142	-0.15	-0.224
50.437	-45.768	12.985	50.527	-45.913	13.302	-0.09	0.145	-0.316	-0.36
47.645	-41.187	14.528	47.696	-41.263	15.126	-0.051	0.077	-0.599	-0.606
45.248	-41.174	15.188	45.194	-41.141	15.165	0.054	-0.033	0.023	0.067
45.239	-46.861	13.072	45.22	-46.998	13.332	0.019	0.137	-0.259	-0.294
44.562	-51.344	9.664	44.543	-51.483	9.791	0.02	0.139	-0.128	-0.19
44.102	-54.413	4.873	44.085	-54.53	4.922	0.017	0.117	-0.049	-0.128
53.643	-25.608	4.821	53.755	-25.471	4.892	-0.112	-0.137	-0.071	-0.191
52.16	-28.303	9.609	52.282	-28.168	9.769	-0.122	-0.135	-0.16	-0.242
49.983	-32.249	13.033	50.11	-32.143	13.318	-0.127	-0.105	-0.285	-0.329
47.294	-36.921	14.577	47.493	-36.934	15.134	-0.199	0.013	-0.557	-0.591
32.461	-49.636	0.368	32.395	-49.685	0.482	0.066	0.05	-0.113	-0.14
36.815	-53.95	0.196	36.771	-54.019	0.338	0.044	0.069	-0.142	-0.164
45.316	-56.217	0.584	45.311	-56.31	0.683	0.005	0.093	-0.099	-0.136
54.559	-53.887	0.772	54.614	-53.985	0.87	-0.055	0.099	-0.098	-0.15
60.637	-47.606	1.895	60.467	-47.505	1.998	0.17	-0.101	-0.103	0.223
62.903	-39.429	1.901	62.752	-39.426	1.998	0.151	-0.003	-0.097	0.18
5.636	29.691	-10.473	5.636	29.485	-10.535	0	0.206	0.062	0.215

2.266	29.715	-10.468		2.266	29.486	-10.537		0	0.23	0.069		0.24
2.259	26.615	0.07		2.259	26.329	-0.016		0	0.286	0.086		0.298
-1.099	29.759	-10.458		-1.099	29.486	-10.539		0	0.272	0.082		0.284
5.642	20.18	-12.715		5.642	20.001	-12.661		0	0.179	-0.054		-0.187
2.264	23.434	-2.229		2.264	23.156	-2.146		0	0.278	-0.083		-0.29
2.276	20.263	-12.744		2.276	20	-12.666		0	0.263	-0.079		-0.274
-1.092	20.217	-12.735		-1.092	19.999	-12.669		0	0.218	-0.065		-0.228
7.972	27.518	-10.627		8.056	27.518	-10.594		-0.084	0	-0.033		-0.09
7.986	24.992	-10.618		8.055	24.992	-10.591		-0.069	0	-0.027		-0.074
3.79	25.007	-0.093		3.846	25.007	-0.07		-0.056	0	-0.023		-0.061
7.979	22.467	-10.618		8.053	22.467	-10.588		-0.074	0	-0.03		-0.08
-4.778	27.51	-12.542		-4.594	27.51	-12.615		-0.184	0	0.073		0.198
-0.381	25	-2.089		-0.384	25	-2.088		0.003	0	-0.001		-0.003
-4.75	24.985	-12.549		-4.593	24.985	-12.612		-0.157	0	0.063		0.169
-4.782	22.461	-12.532		-4.592	22.461	-12.608		-0.19	0	0.076		0.205
-8.987	4.953	-2.114		-9.214	5.078	-2.114		0.227	-0.125	0		0.259
-9.073	5.013	9.672		-9.209	5.088	9.672		0.135	-0.075	0		0.155
-0.529	10.466	9.668		-0.531	10.507	9.668		0.002	-0.041	0		0.041
-0.505	10.311	-2.113		-0.515	10.508	-2.113		0.01	-0.198	0		0.198
8.439	5.959	-2.101		8.594	6.069	-2.101		-0.155	-0.11	0		0.19
8.634	6.134	9.683		8.577	6.093	9.683		0.057	0.041	0		-0.07
10.204	-3.318	9.694		10.005	-3.253	9.694		0.198	-0.065	0		-0.209
9.932	-3.24	0.855		10.002	-3.263	0.855		-0.07	0.023	0		0.074
0.141	-10.452	0.858		0.142	-10.52	0.858		-0.001	0.068	0		0.068
0.134	-10.633	9.696		0.133	-10.52	9.696		0.001	-0.113	0		-0.113
-9.898	-3.306	9.678		-9.979	-3.333	9.678		0.081	0.027	0		0.086
-9.732	-3.272	0.84		-9.972	-3.353	0.84		0.24	0.081	0		0.253
10.861	-10.239	3.818		10.717	-10.104	3.818		0.144	-0.135	0		0.197
-11.137	-9.657	3.795		-11.128	-9.649	3.795		-0.009	-0.008	0		0.012
-14.564	1.883	0.825		-14.608	1.889	0.825		0.044	-0.006	0		-0.044
-8.238	12.115	3.76		-8.282	12.18	3.76		0.044	-0.065	0		-0.078
3.584	14.358	0.823		3.567	14.291	0.823		0.017	0.068	0		0.07
13.086	6.992	3.791		12.991	6.942	3.791		0.095	0.051	0		0.108
2.006	2.095	-16.154		2.006	2.095	-16.833		0	0	0.68		0.68
-3.67	3.767	-15.989		-3.67	3.767	-16.833		0	0	0.844		0.844
-3.751	-4.166	-15.983		-3.751	-4.166	-16.833		0	0	0.85		0.85
3.823	-4.019	-15.987		3.823	-4.019	-16.833		0	0	0.847		0.847
-0.92	-0.562	-19.139		-1.445	-1.084	-19.139		0.525	0.523	0		0.741
-9.271	-8.549	13.275		-9.271	-8.549	12.625		0	0	0.65		0.65
-11.913	3.51	13.348		-11.913	3.51	12.625		0	0	0.723		0.723
-0.842	11.993	13.363		-0.842	11.993	12.625		0	0	0.738		0.738

11.32	4.925	13.158		11.32	4.925	12.625		0	0	0.533		0.533
10.669	-7.015	13.066		10.669	-7.015	12.625		0	0	0.441		0.441
0.533	-12.823	13.172		0.533	-12.823	12.625		0	0	0.547		0.547
-0.348	-14.772	6.9		-0.347	-14.725	6.9		-0.001	-0.047	0		0.047
7.028	-46.792	6.813		6.972	-46.792	6.813		0.056	0	0		0.056
7.055	-36.785	6.799		6.972	-36.785	6.799		0.083	0	0		0.083
7.094	-26.778	6.784		6.972	-26.778	6.784		0.122	0	0		0.122
7.108	-16.771	6.769		6.972	-16.771	6.769		0.136	0	0		0.136
4.576	-17.735	6.763		4.447	-17.735	6.763		0.129	0	0		-0.129
4.539	-27.456	6.779		4.447	-27.456	6.779		0.092	0	0		-0.092
4.524	-37.179	6.794		4.447	-37.179	6.794		0.077	0	0		-0.077
4.515	-46.901	6.807		4.447	-46.901	6.807		0.068	0	0		-0.068
-3.859	-46.911	9.75		-3.97	-46.911	9.75		0.111	0	0		0.111
-3.82	-37.227	9.734		-3.97	-37.227	9.734		0.149	0	0		0.149
-3.813	-27.542	9.721		-3.97	-27.542	9.721		0.157	0	0		0.157
-3.856	-17.858	9.706		-3.97	-17.858	9.706		0.113	0	0		0.113
-8.074	-16.129	3.804		-8.178	-16.129	3.804		0.104	0	0		-0.104
-8.12	-26.328	3.819		-8.178	-26.328	3.819		0.058	0	0		-0.058
-8.136	-36.529	3.834		-8.178	-36.529	3.834		0.042	0	0		-0.042
-8.104	-46.729	3.85		-8.178	-46.729	3.85		0.074	0	0		-0.074
-5.948	-50.584	7.258		-5.948	-50.5	7.258		0	-0.084	0		0.084
5.8	-50.431	10.504		5.8	-50.5	10.504		0	0.069	0		-0.069
5.791	-46.552	12.892		5.791	-46.552	12.625		0	0	0.267		0.267
5.809	-37.506	12.935		5.809	-37.506	12.625		0	0	0.31		0.31
5.716	-28.463	13.033		5.716	-28.463	12.625		0	0	0.408		0.408
5.943	-17.494	13.065		5.943	-17.494	12.625		0	0	0.44		0.44
-6.047	-16.938	13.173		-6.047	-16.938	12.625		0	0	0.548		0.548
-6.166	-27.342	13.174		-6.166	-27.342	12.625		0	0	0.549		0.549
-6.188	-36.161	13.11		-6.188	-36.161	12.625		0	0	0.485		0.485
-5.726	-47.914	12.959		-5.726	-47.914	12.625		0	0	0.334		0.334
63.127	-85.8	0.227		63.127	-85.8	0		0	0	0.227		0.227
51.698	-86.17	0.205		51.698	-86.17	0		0	0	0.205		0.205
30.952	-85.694	0.142		30.952	-85.694	0		0	0	0.142		0.142
26.966	-77.976	0.123		26.966	-77.976	0		0	0	0.123		0.123
40.151	-79.701	0.141		40.151	-79.701	0		0	0	0.141		0.141
56.587	-76.308	0.101		56.587	-76.308	0		0	0	0.101		0.101
61.235	-67.009	-0.061		61.235	-67.009	0		0	0	-0.061		-0.061
47.244	-70.263	0.015		47.244	-70.263	0		0	0	0.015		0.015
37.724	-65.87	0.007		37.724	-65.87	0		0	0	0.007		0.007
24.074	-65.541	0.068		24.074	-65.541	0		0	0	0.068		0.068
20.111	-53.44	0.105		20.111	-53.44	0		0	0	0.105		0.105

15.342	-46.314	0.213	15.342	-46.314	0	0	0	0.213	0.213
23.751	-45.567	0.073	23.751	-45.567	0	0	0	0.073	0.073
14.988	-35.379	0.244	14.988	-35.379	0	0	0	0.244	0.244
15.852	-25.42	0.263	15.852	-25.42	0	0	0	0.263	0.263
25.764	-28.356	0.086	25.764	-28.356	0	0	0	0.086	0.086
33.748	-23.362	0.017	33.748	-23.362	0	0	0	0.017	0.017
61.84	-24.504	-0.597	61.84	-24.504	0	0	0	-0.597	-0.597
67.279	-35.023	0.111	66.907	-35.023	0	0.371	0	0.111	0.387
65.42	-54.992	-0.281	65.42	-54.992	0	0	0	-0.281	-0.281
69.072	-6.573	-0.755	69.072	-6.573	0	0	0	-0.755	-0.755
66.24	18.424	-0.341	66.24	18.424	0	0	0	-0.341	-0.341
52.333	19	-0.179	52.333	19	0	0	0	-0.179	-0.179
38.456	18.749	-0.016	38.456	18.749	0	0	0	-0.016	-0.016
25.103	19.072	0.235	25.103	19.072	0	0	0	0.235	0.235
27.203	28.531	0.162	27.203	28.531	0	0	0	0.162	0.162
34.344	26.869	0.056	34.344	26.869	0	0	0	0.056	0.056
46.086	25.935	-0.095	46.086	25.935	0	0	0	-0.095	-0.095
45.77	34.478	-0.018	45.77	34.478	0	0	0	-0.018	-0.018
29.795	39.387	0.105	29.795	39.387	0	0	0	0.105	0.105
17.438	42.23	0.131	17.438	42.23	0	0	0	0.131	0.131
7.198	39.355	0.22	7.198	39.355	0	0	0	0.22	0.22
10.367	49.408	0.095	10.367	49.408	0	0	0	0.095	0.095
23.054	52.373	0.087	23.054	52.373	0	0	0	0.087	0.087
43.353	55.627	0.105	43.353	55.627	0	0	0	0.105	0.105
66.545	54.299	0.112	66.545	54.299	0	0	0	0.112	0.112
67.137	38.321	-0.06	67.137	38.321	0	0	0	-0.06	-0.06
-12.086	40.825	0.121	-12.086	40.825	0	0	0	0.121	0.121
-22.659	17.531	0.287	-22.659	17.531	0	0	0	0.287	0.287
-23.964	30.721	0.171	-23.964	30.721	0	0	0	0.171	0.171
-31.141	26.034	0.16	-31.141	26.034	0	0	0	0.16	0.16
-42.872	26.694	0.123	-42.872	26.694	0	0	0	0.123	0.123
-50.365	30.545	0.056	-50.365	30.545	0	0	0	0.056	0.056
-40.322	46.099	0.025	-40.322	46.099	0	0	0	0.025	0.025
-47.446	54.655	-0.113	-47.446	54.655	0	0	0	-0.113	-0.113
-75.458	53.865	-0.209	-75.458	53.865	0	0	0	-0.209	-0.209
-75.67	37.583	-0.189	-75.67	37.583	0	0	0	-0.189	-0.189
-74.453	19.426	-0.136	-74.453	19.426	0	0	0	-0.136	-0.136
-56.976	25.331	0.074	-56.976	25.331	0	0	0	0.074	0.074
-66.012	12.022	0.055	-66.012	12.022	0	0	0	0.055	0.055
-68.524	-1.037	0.042	-68.524	-1.037	0	0	0	0.042	0.042
-76.876	-10.733	-0.198	-76.876	-10.733	0	0	0	-0.198	-0.198

-76.735	-29.207	-0.17	-76.735	-29.207	0	0	0	-0.17	-0.17
-62.47	-24.803	0.134	-62.47	-24.803	0	0	0	0.134	0.134
-49.784	-21.838	0.195	-49.784	-21.838	0	0	0	0.195	0.195
-35.455	-26.537	0.223	-35.455	-26.537	0	0	0	0.223	0.223
-22.701	-18.05	0.317	-22.701	-18.05	0	0	0	0.317	0.317
-27.71	-36.998	0.201	-27.71	-36.998	0	0	0	0.201	0.201
-13.579	-51.078	0.071	-13.579	-51.078	0	0	0	0.071	0.071
-5.077	-60.131	0.03	-5.077	-60.131	0	0	0	0.03	0.03
-6.311	-70.935	-0.052	-6.311	-70.935	0	0	0	-0.052	-0.052
-7.653	-86.153	0	-7.653	-86.153	0	0	0	0	0
-27.08	-90.751	0.019	-27.08	-90.751	0	0	0	0.019	0.019
-40.773	-88.511	-0.021	-40.773	-88.511	0	0	0	-0.021	-0.021
-53.53	-82.102	0.074	-53.53	-82.102	0	0	0	0.074	0.074
-62.738	-90.727	0.056	-62.738	-90.727	0	0	0	0.056	0.056
-77.066	-86.029	0.038	-77.066	-86.029	0	0	0	0.038	0.038
-75.413	-64.457	-0.079	-75.413	-64.457	0	0	0	-0.079	-0.079
-71.809	-44.187	0.003	-71.809	-44.187	0	0	0	0.003	0.003
-65.653	-56.088	0.114	-65.653	-56.088	0	0	0	0.114	0.114
-62.023	-65.879	0.105	-62.023	-65.879	0	0	0	0.105	0.105
-50.309	-58.813	0.134	-50.309	-58.813	0	0	0	0.134	0.134
-50.061	-72.869	0.059	-50.061	-72.869	0	0	0	0.059	0.059
-13.927	-37.962	-16.529	-13.927	-37.962	-16.833	0	0	0.304	0.304
-14.326	-16.561	-16.355	-14.326	-16.561	-16.833	0	0	0.478	0.478
-13.515	16.114	-16.379	-13.515	16.114	-16.833	0	0	0.455	0.455
-13.348	29.32	-16.567	-13.348	29.32	-16.833	0	0	0.266	0.266
14.712	31.587	-16.629	14.712	31.587	-16.833	0	0	0.204	0.204
15.58	23.882	-16.533	15.58	23.882	-16.833	0	0	0.3	0.3
15.847	12.19	-16.304	15.847	12.19	-16.833	0	0	0.529	0.529
60.034	4.283	-16.284	60.034	4.283	-16.833	0	0	0.55	0.55
58.478	-9.989	-16.472	58.478	-9.989	-16.833	0	0	0.361	0.361
48.986	-15.284	-16.916	48.986	-15.284	-16.833	0	0	-0.082	-0.082
36.576	-9.691	-16.607	36.576	-9.691	-16.833	0	0	0.227	0.227
30.808	-17.715	-16.8	30.808	-17.715	-16.833	0	0	0.033	0.033
13.35	-15.201	-16.324	13.35	-15.201	-16.833	0	0	0.509	0.509
19.625	2.804	-3.631	19.625	2.804	-4.208	0	0	0.577	0.577
29.011	7.214	-3.891	29.011	7.214	-4.208	0	0	0.317	0.317
34.537	2.956	-3.846	34.537	2.956	-4.208	0	0	0.362	0.362
41.29	7.339	-3.997	41.29	7.339	-4.208	0	0	0.211	0.211
46.517	2.154	-3.814	46.517	2.154	-4.208	0	0	0.394	0.394
52.114	8.374	-4.117	52.114	8.374	-4.208	0	0	0.091	0.091
50.944	-4.119	-0.039	50.944	-4.03	0	0	-0.089	-0.039	-0.097

40.42	-3.012	0.465		40.42	-3.012	0		0	0	0.465		0.465
28.727	-2.824	0.372		28.727	-2.824	0		0	0	0.372		0.372
17.038	-2.022	-0.158		17.038	-2.022	0		0	0	-0.158		-0.158
18.658	-9.347	1.965		18.658	-9.347	1.683		0	0	0.282		0.282
24.816	-6.509	1.969		24.816	-6.509	1.683		0	0	0.286		0.286
25.931	-14.817	1.766		25.931	-14.817	1.683		0	0	0.082		0.082
18.898	-12.017	-4.067		18.898	-12.447	-4.067		0	0.43	0		-0.43
24.814	-16.681	0.327		24.59	-16.655	0.327		0.224	-0.026	0		0.226
33.105	-3.627	-4.132		33.105	-4.03	-4.132		0	0.403	0		-0.403
40.126	-3.574	-3.37		40.126	-4.03	-3.37		0	0.456	0		-0.456
52.749	-3.54	-4.635		52.749	-4.03	-4.635		0	0.491	0		-0.491
54.838	0.226	-8.915		55.258	0.092	-8.915		-0.42	0.134	0		-0.441
56.132	7.879	-9.671		56.527	7.879	-9.671		-0.396	0	0		-0.396
59.576	12.496	-0.88		59.576	12.374	-0.618		0	0.122	-0.262		-0.289
49.361	13.295	-1.559		49.361	13.183	-1.365		0	0.112	-0.194		-0.224
39.522	12.5	-1.419		39.522	12.39	-1.309		0	0.109	-0.109		-0.155

*Appendix J      Titanium Castings -  
Histograms (3D-Tol  
Data)*

Histogram for 3DP Titanium Casting

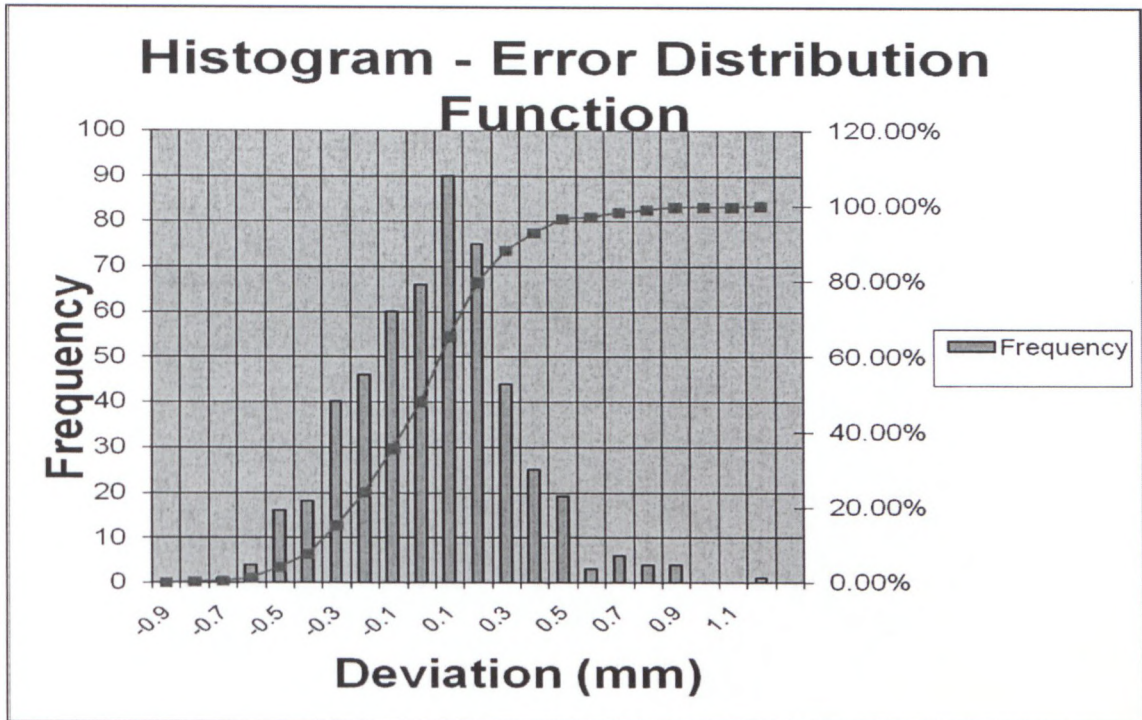

Histogram for SLS Titanium Casting

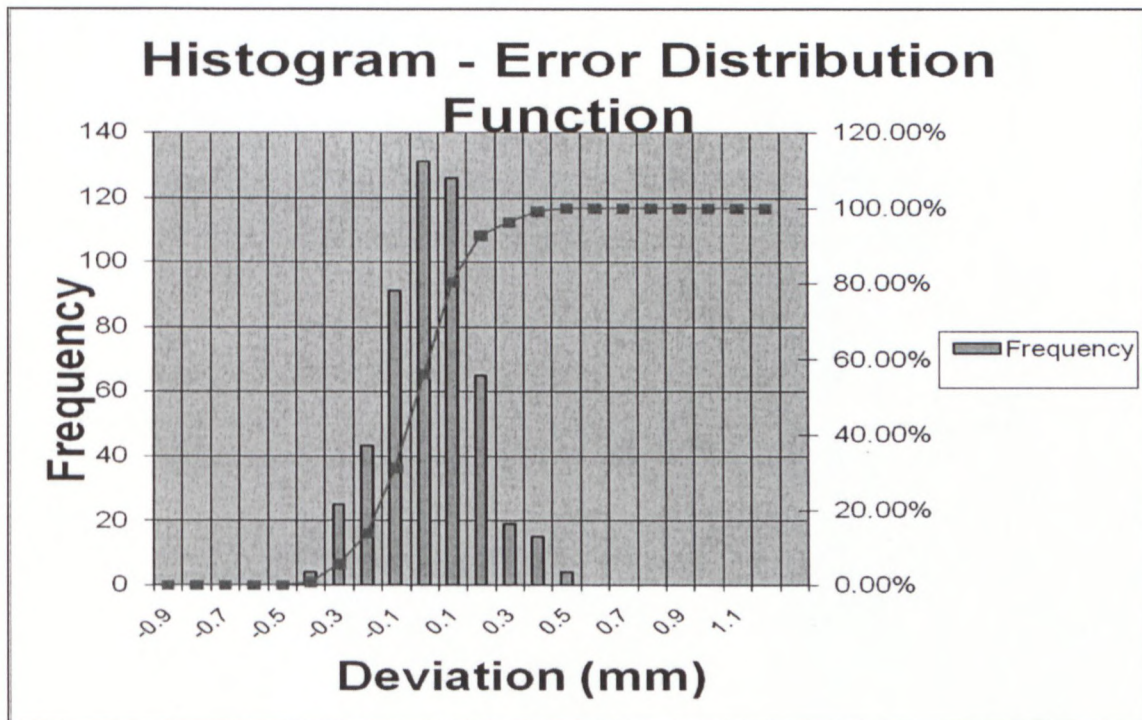

Histogram for Alumide Titanium Casting

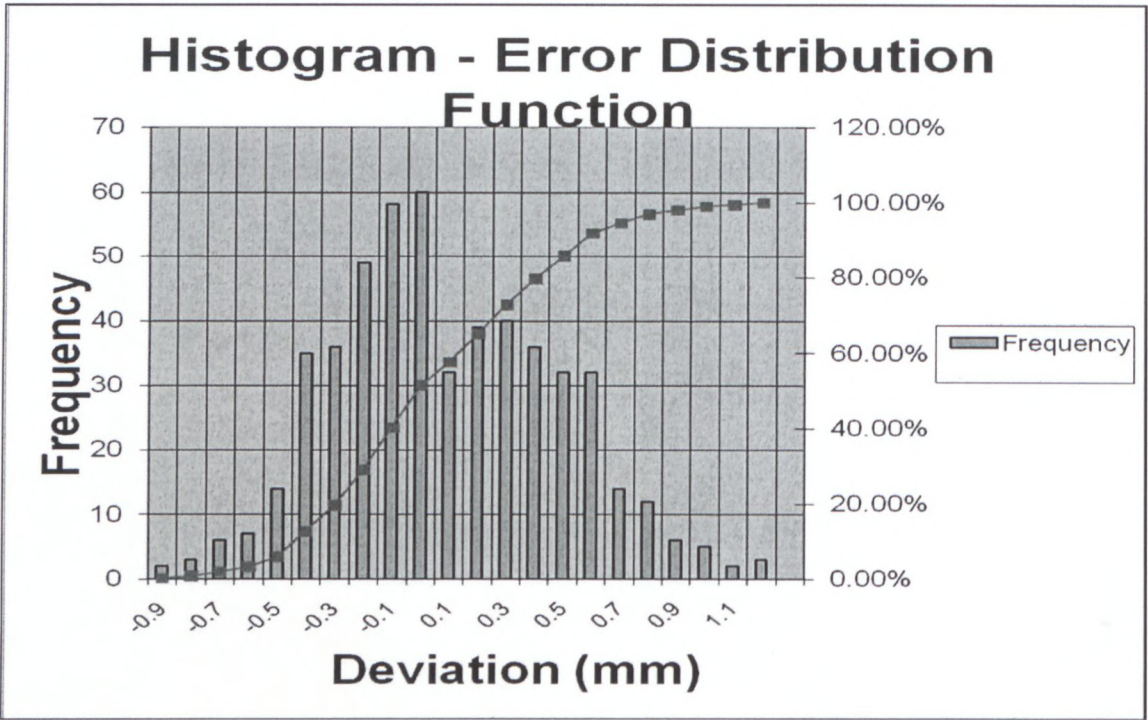

Histogram for Polyamide Titanium Casting

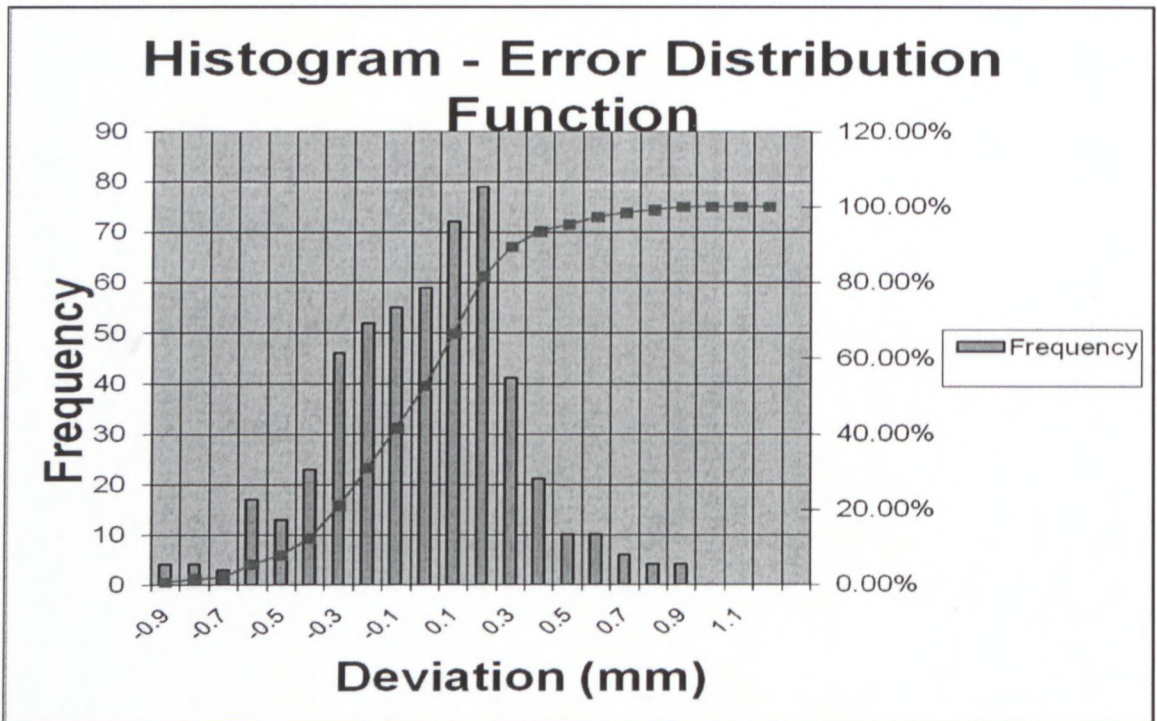

*Appendix K      Pattern - Statistical  
CMM Raw Data (3D-  
Tol Data)*

### 3D-Tol Data from CMM for Pattern f

MEAS X	MEAS Y	MEAS Z	CAD X	CAD Y	CAD Z	DIF X	DIF Y	DIF Z	TOT DIF
-232.683	-54.791	-5.96	-232.997	-54.865	-5.96	0.315	0.074	0	0.323
-238.44	15.851	-6	-238.843	15.878	-6	0.403	-0.027	0	0.403
-223.314	85.079	-6.04	-223.686	85.221	-6.04	0.372	-0.142	0	0.398
-188.334	146.672	-6.081	-188.855	147.077	-6.081	0.521	-0.406	0	0.66
-136.715	195.013	-6.117	-137.408	196.002	-6.117	0.694	-0.989	0	1.208
-73.368	226.117	-6.146	-73.877	227.684	-6.146	0.509	-1.567	0	1.648
1.432	238.511	-6.166	1.437	239.366	-6.166	-0.005	-0.855	0	0.855
71.279	227.43	-6.173	71.588	228.414	-6.173	-0.309	-0.985	0	1.032
134.515	196.02	-6.167	135.44	197.368	-6.167	-0.925	-1.348	0	1.634
186.519	148.284	-6.149	187.372	148.962	-6.149	-0.853	-0.678	0	1.09
222.303	87.248	-6.122	222.823	87.452	-6.122	-0.52	-0.204	0	0.559
238.331	18.236	-6.086	238.672	18.262	-6.086	-0.341	-0.026	0	0.342
233.322	-52.481	-6.045	233.535	-52.529	-6.045	-0.213	0.048	0	0.218
207.703	-118.609	-6.005	207.865	-118.702	-6.005	-0.162	0.093	0	0.187
163.776	-174.275	-5.965	163.925	-174.432	-5.965	-0.148	0.158	0	0.217
105.436	-214.532	-5.932	105.581	-214.827	-5.932	-0.145	0.295	0	0.329
37.862	-235.746	-5.909	37.957	-236.341	-5.909	-0.096	0.595	0	0.603
-32.87	-236.163	-5.895	-32.998	-237.085	-5.895	0.128	0.921	0	0.93
-100.802	-216.454	-5.893	-101.054	-216.993	-5.893	0.251	0.539	0	0.595
-159.996	-177.57	-5.904	-160.232	-177.831	-5.904	0.235	0.261	0	0.352
-228.249	-53.751	-20.02	-228.563	-53.825	-20.207	0.315	0.074	0.187	0.373
-231.62	15.383	-24.072	-231.959	15.406	-24.269	0.34	-0.023	0.197	0.393
-219.006	83.428	-20.049	-219.39	83.574	-20.286	0.384	-0.146	0.237	0.474
-182.936	142.455	-24.023	-183.381	142.802	-24.348	0.445	-0.347	0.326	0.651
-134.269	191.513	-19.875	-134.749	192.198	-20.358	0.48	-0.685	0.483	0.966
-71.404	220.048	-23.802	-71.727	221.045	-24.407	0.323	-0.997	0.605	1.21
1.406	234.359	-20.206	1.408	234.698	-20.402	-0.002	-0.339	0.196	0.392
69.387	221.391	-24.215	69.497	221.743	-24.428	-0.11	-0.352	0.213	0.425
132.243	192.704	-19.827	132.803	193.52	-20.398	-0.56	-0.815	0.571	1.142
181.355	144.167	-23.986	181.917	144.614	-24.401	-0.562	-0.447	0.415	0.829
218.076	85.586	-20.086	218.506	85.755	-20.353	-0.429	-0.169	0.266	0.533
231.36	17.69	-24.107	231.755	17.721	-24.336	-0.395	-0.03	0.229	0.457
228.786	-51.47	-20.12	229.05	-51.53	-20.277	-0.264	0.059	0.156	0.312
201.764	-115.232	-24.185	201.873	-115.294	-24.257	-0.109	0.062	0.072	0.145
160.697	-171.006	-20.109	160.804	-171.121	-20.2	-0.108	0.115	0.091	0.182
102.463	-208.503	-24.077	102.55	-208.679	-24.191	-0.086	0.176	0.113	0.226
37.167	-231.445	-19.893	37.237	-231.879	-20.147	-0.07	0.434	0.254	0.508
-31.966	-229.671	-23.78	-32.056	-230.315	-24.156	0.09	0.644	0.376	0.751
-98.98	-212.547	-19.913	-99.145	-212.902	-20.138	0.165	0.354	0.226	0.451

-155.474	-172.56	-24.026	-155.645	-172.75	-24.173	0.171	0.19	0.148	0.295
-221.665	-52.211	-40.537	-221.688	-52.217	-40.537	0.024	0.006	0	0.024
-227.031	15.069	-35.041	-227.255	15.084	-35.041	0.224	-0.015	0	0.225
-212.591	80.967	-40.615	-212.841	81.063	-40.615	0.25	-0.095	0	0.267
-179.264	139.584	-35.119	-179.703	139.926	-35.119	0.439	-0.342	0	0.557
-130.2	185.684	-40.687	-130.758	186.48	-40.687	0.558	-0.795	0	0.971
-69.87	215.3	-35.181	-70.303	216.633	-35.181	0.433	-1.333	0	1.402
65.463	217.48	-35.208	65.646	218.089	-35.208	-0.183	-0.609	0	0.636
125.822	188.443	-40.735	126.47	189.414	-40.735	-0.649	-0.971	0	1.168
175.623	143.713	-35.186	176.262	144.236	-35.186	-0.639	-0.523	0	0.826
210.304	86.325	-40.694	210.696	86.485	-40.694	-0.391	-0.161	0	0.423
226.563	21.187	-35.126	226.766	21.206	-35.126	-0.203	-0.019	0	0.204
223.061	-45.911	-40.621	223.079	-45.915	-40.621	-0.017	0.004	0	0.018
199.927	-109.005	-35.05	199.965	-109.025	-35.05	-0.037	0.02	0	0.043
159.344	-162.55	-40.545	159.435	-162.643	-40.545	-0.091	0.093	0	0.13
104.915	-201.857	-34.981	105.035	-202.089	-34.981	-0.121	0.232	0	0.261
41.384	-223.367	-40.49	41.491	-223.944	-40.49	-0.107	0.577	0	0.587
-25.545	-225.297	-34.943	-25.659	-226.305	-34.943	0.114	1.008	0	1.014
-90.417	-208.594	-40.474	-90.58	-208.968	-40.474	0.162	0.374	0	0.408
-147.469	-173.267	-34.95	-147.616	-173.441	-34.95	0.148	0.174	0	0.228
-76.878	-179.211	-60.357	-76.878	-179.211	-60.095	0	0	-0.262	-0.262
76.662	-179.29	-60.279	76.662	-179.29	-60.095	0	0	-0.184	-0.184
-179.187	-76.783	-60.049	-179.187	-76.783	-60.095	0	0	0.046	0.046
179.077	-76.97	-59.985	179.077	-76.97	-60.095	0	0	0.11	0.11
-179.108	76.778	-60.133	-179.108	76.778	-60.095	0	0	-0.038	-0.038
179.157	76.592	-60.122	179.157	76.592	-60.095	0	0	-0.027	-0.027
-76.694	179.098	-60.37	-76.694	179.098	-60.095	0	0	-0.275	-0.275
76.848	179.017	-60.522	76.848	179.017	-60.095	0	0	-0.427	-0.427
-55.595	-129.6	-60.431	-55.595	-129.6	-60.095	0	0	-0.336	-0.336
55.432	-129.658	-60.433	55.432	-129.658	-60.095	0	0	-0.338	-0.338
-129.576	-55.542	-60.257	-129.576	-55.542	-60.095	0	0	-0.162	-0.162
129.488	-55.678	-60.215	129.488	-55.678	-60.095	0	0	-0.12	-0.12
-129.52	55.485	-60.328	-129.52	55.485	-60.095	0	0	-0.233	-0.233
129.547	55.351	-60.269	129.547	55.351	-60.095	0	0	-0.174	-0.174
-55.462	129.465	-60.55	-55.462	129.465	-60.095	0	0	-0.455	-0.455
55.566	129.407	-60.567	55.566	129.407	-60.095	0	0	-0.472	-0.472
41.464	169.5	-86.101	41.431	169.361	-85.655	0.034	0.139	-0.445	-0.467
45.526	186.1	-65.558	45.526	186.102	-65.558	0	-0.001	0	0.002
114.748	152.823	-65.474	115.038	153.21	-65.55	-0.29	-0.386	0.076	0.489
104.743	139.488	-85.874	104.701	139.431	-85.652	0.043	0.057	-0.222	-0.233
151.133	87.049	-85.67	151.124	87.044	-85.641	0.008	0.005	-0.029	-0.031

165.673	95.446	-65.457	166.015	95.644	-65.519	-0.342	-0.197	0.062	0.4
190.01	22.65	-65.439	190.255	22.679	-65.478	-0.245	-0.029	0.038	0.25
173.174	20.625	-85.481	173.221	20.631	-85.627	-0.047	-0.006	0.146	0.153
167.443	-49.128	-85.611	167.442	-49.128	-85.608	0.001	0	-0.002	-0.002
183.791	-53.902	-65.414	183.866	-53.924	-65.426	-0.075	0.022	0.012	0.079
147.856	-121.818	-65.369	147.889	-121.845	-65.375	-0.033	0.027	0.006	0.043
134.702	-111.005	-85.569	134.708	-111.009	-85.591	-0.006	0.005	0.022	0.023
80.287	-155.045	-85.588	80.286	-155.042	-85.577	0.002	-0.003	-0.011	-0.011
87.972	-169.855	-65.28	88.128	-170.157	-65.33	-0.156	0.301	0.051	0.343
14.134	-190.248	-65.169	14.197	-191.103	-65.296	-0.064	0.855	0.127	0.867
12.929	-174.116	-85.478	12.931	-174.146	-85.567	-0.002	0.03	0.089	0.094
-56.518	-165.256	-85.638	-56.51	-165.233	-85.566	-0.008	-0.023	-0.072	-0.076
-61.854	-180.86	-65.221	-62.011	-181.319	-65.293	0.157	0.459	0.072	0.491
-128.215	-142.337	-65.302	-128.254	-142.38	-65.31	0.039	0.043	0.009	0.059
-116.875	-129.76	-85.65	-116.857	-129.741	-85.573	-0.017	-0.019	-0.077	-0.082
-179.452	-67.341	-65.346	-179.407	-67.324	-65.338	-0.045	-0.017	-0.007	-0.049
-163.422	-61.341	-85.55	-163.434	-61.346	-85.586	0.011	0.004	0.036	0.038
-174.342	7.808	-85.595	-174.344	7.808	-85.602	0.002	0	0.008	0.008
-191.459	8.595	-65.391	-191.423	8.593	-65.386	-0.035	0.002	-0.005	-0.036
-172.34	82.995	-65.387	-172.633	83.136	-65.436	0.293	-0.141	0.05	0.329
-157.18	75.671	-85.578	-157.193	75.677	-85.621	0.013	-0.006	0.044	0.046
-114.749	131.345	-85.624	-114.751	131.348	-85.637	0.003	-0.003	0.013	0.014
-125.685	143.891	-65.401	-126.045	144.303	-65.486	0.36	-0.412	0.085	0.554
-58.977	181.688	-65.432	-59.155	182.234	-65.522	0.177	-0.546	0.09	0.582
-53.872	165.928	-85.888	-53.849	165.854	-85.648	-0.024	0.073	-0.239	-0.251
-23.436	-163.415	-87.102	-23.436	-163.415	-86.86	0	0	-0.242	-0.242
-0.106	-163.427	-87.108	-0.106	-163.427	-86.86	0	0	-0.248	-0.248
23.225	-163.44	-87.098	23.225	-163.44	-86.86	0	0	-0.238	-0.238
69.901	-140.131	-87.036	69.901	-140.131	-86.86	0	0	-0.176	-0.176
-70.086	-140.06	-87.13	-70.086	-140.06	-86.86	0	0	-0.27	-0.27
-116.737	-116.704	-87.009	-116.737	-116.704	-86.86	0	0	-0.149	-0.149
116.574	-116.825	-86.899	116.574	-116.825	-86.86	0	0	-0.039	-0.039
-140.043	-70.031	-86.927	-140.043	-70.031	-86.86	0	0	-0.067	-0.067
139.928	-70.175	-86.825	139.928	-70.175	-86.86	0	0	0.035	0.035
-163.35	-23.357	-86.827	-163.35	-23.357	-86.86	0	0	0.033	0.033
163.283	-23.525	-86.737	163.283	-23.525	-86.86	0	0	0.123	0.123
163.296	-0.194	-86.901	163.296	-0.194	-86.86	0	0	-0.041	-0.041
-163.338	-0.026	-86.861	-163.338	-0.026	-86.86	0	0	-0.001	-0.001
-163.326	23.305	-86.911	-163.326	23.305	-86.86	0	0	-0.051	-0.051
163.308	23.137	-86.8	163.308	23.137	-86.86	0	0	0.06	0.06
-139.97	69.954	-86.969	-139.97	69.954	-86.86	0	0	-0.109	-0.109

140.001	69.81	-86.992	140.001	69.81	-86.86	0	0	-0.132	-0.132
-116.616	116.604	-86.989	-116.616	116.604	-86.86	0	0	-0.129	-0.129
116.694	116.484	-87.129	116.694	116.484	-86.86	0	0	-0.269	-0.269
70.043	139.84	-87.233	70.043	139.84	-86.86	0	0	-0.373	-0.373
-69.943	139.912	-87.249	-69.943	139.912	-86.86	0	0	-0.389	-0.389
-23.267	163.219	-87.312	-23.267	163.219	-86.86	0	0	-0.452	-0.452
0.063	163.206	-87.347	0.063	163.206	-86.86	0	0	-0.487	-0.487
23.394	163.194	-87.201	23.394	163.194	-86.86	0	0	-0.341	-0.341
-98.645	-109.537	-83.247	-98.647	-109.538	-83.245	0.001	0.001	-0.002	-0.003
-103.184	-114.571	-86.903	-103.203	-114.592	-86.721	0.019	0.021	-0.183	-0.185
-65.079	-139.78	-86.972	-65.095	-139.814	-86.723	0.016	0.034	-0.25	-0.252
-62.145	-133.48	-83.433	-62.222	-133.644	-83.254	0.077	0.164	-0.179	-0.255
-20.241	-145.392	-83.878	-20.328	-146.014	-83.258	0.087	0.622	-0.621	-0.883
-21.264	-152.721	-86.962	-21.269	-152.757	-86.723	0.005	0.036	-0.238	-0.241
24.424	-152.239	-86.996	24.431	-152.28	-86.723	-0.007	0.041	-0.273	-0.276
23.302	-145.245	-83.572	23.352	-145.561	-83.257	-0.051	0.315	-0.315	-0.449
64.933	-132.216	-83.376	64.987	-132.324	-83.256	-0.053	0.109	-0.12	-0.17
67.97	-138.397	-86.87	67.98	-138.418	-86.72	-0.01	0.021	-0.15	-0.151
105.551	-112.4	-86.727	105.552	-112.401	-86.718	-0.001	0.001	-0.01	-0.01
100.947	-107.502	-83.207	100.914	-107.467	-83.255	0.033	-0.035	0.048	0.068
128.086	-73.221	-83.132	127.981	-73.161	-83.252	0.105	-0.06	0.12	0.17
133.853	-76.514	-86.636	133.843	-76.508	-86.714	0.011	-0.006	0.077	0.078
150.38	-33.897	-86.589	150.361	-33.893	-86.708	0.019	-0.004	0.119	0.121
143.968	-32.455	-83.078	143.802	-32.418	-83.246	0.166	-0.037	0.168	0.239
147.123	11.19	-83.104	146.983	11.179	-83.243	0.14	0.011	0.138	0.197
153.665	11.691	-86.659	153.658	11.69	-86.703	0.007	0.001	0.044	0.045
143.435	56.236	-86.734	143.441	56.238	-86.698	-0.005	-0.002	-0.036	-0.036
137.317	53.832	-83.152	137.235	53.8	-83.239	0.082	0.032	0.086	0.123
115.434	91.719	-83.201	115.407	91.697	-83.236	0.027	0.022	0.034	0.049
120.59	95.815	-86.887	120.615	95.835	-86.695	-0.025	-0.02	-0.192	-0.195
87.147	126.949	-86.989	87.176	126.99	-86.692	-0.028	-0.041	-0.297	-0.301
83.423	121.525	-83.223	83.419	121.519	-83.231	0.004	0.006	0.007	0.01
44.116	140.736	-83.13	44.087	140.643	-83.225	0.029	0.093	0.095	0.136
46.057	146.932	-86.946	46.07	146.973	-86.69	-0.013	-0.041	-0.256	-0.259
0.083	154.031	-86.638	0	154.023	-86.69	0.083	0.009	0.052	0.098
0.871	147.405	-83.209	0.87	147.388	-83.225	0	0.017	0.016	0.023
-45.471	140.015	-83.402	-45.526	140.185	-83.227	0.055	-0.17	-0.175	-0.251
-47.555	146.442	-87.11	-47.576	146.509	-86.693	0.022	-0.067	-0.417	-0.423
-88.445	126.066	-87.032	-88.478	126.112	-86.695	0.032	-0.046	-0.336	-0.341
-84.555	120.514	-83.403	-84.657	120.659	-83.229	0.102	-0.145	-0.173	-0.248
-116.207	90.414	-83.385	-116.332	90.511	-83.23	0.125	-0.097	-0.155	-0.221

-121.574	94.599	-86.934	-121.604	94.623	-86.7	0.03	-0.024	-0.234	-0.237
-144.019	54.796	-86.815	-144.036	54.802	-86.704	0.017	-0.006	-0.111	-0.112
-137.769	52.413	-83.226	-137.764	52.411	-83.231	-0.005	0.002	0.005	0.008
-147.212	9.715	-83.102	-147.079	9.707	-83.233	-0.133	0.009	0.131	0.187
-153.802	10.154	-86.73	-153.805	10.155	-86.709	0.003	0	-0.021	-0.021
-150.049	-35.395	-86.719	-150.049	-35.396	-86.714	0.001	0	-0.005	-0.005
-143.649	-33.887	-83.055	-143.467	-33.844	-83.239	-0.182	-0.043	0.184	0.263
-44.493	137.023	-67.362	-44.449	136.889	-67.362	-0.043	0.134	0	0.141
-82.579	117.713	-61.486	-82.657	117.823	-61.486	0.077	-0.11	0	-0.134
-113.556	88.37	-67.323	-113.584	88.392	-67.323	0.028	-0.022	0	-0.035
-134.502	51.185	-61.439	-134.514	51.189	-61.439	0.013	-0.005	0	-0.013
-143.911	9.505	-67.272	-143.612	9.486	-67.272	-0.299	0.02	0	0.299
-140.55	-33.147	-61.391	-140.082	-33.036	-61.391	-0.468	-0.11	0	0.481
-96.535	-107.189	-67.213	-96.317	-106.946	-67.213	-0.218	-0.242	0	0.326
-60.711	-130.406	-61.348	-60.745	-130.478	-61.348	0.034	0.072	0	-0.08
-19.763	-141.965	-67.207	-19.844	-142.55	-67.207	0.081	0.585	0	-0.591
22.747	-141.759	-61.355	22.803	-142.107	-61.355	-0.056	0.348	0	-0.352
63.461	-129.204	-67.228	63.451	-129.183	-67.228	0.01	-0.02	0	0.023
98.704	-105.098	-61.39	98.529	-104.911	-61.39	0.175	-0.187	0	0.256
125.21	-71.566	-67.271	124.954	-71.42	-67.271	0.255	-0.146	0	0.294
140.596	-31.685	-61.438	140.404	-31.642	-61.438	0.193	-0.043	0	0.197
143.665	10.935	-67.321	143.51	10.923	-67.321	0.155	0.012	0	0.155
134.054	52.564	-61.486	133.992	52.54	-61.486	0.062	0.024	0	0.066
112.826	89.649	-67.361	112.684	89.536	-67.361	0.142	0.113	0	0.181
81.568	118.83	-61.515	81.451	118.659	-61.515	0.117	0.17	0	0.206
43.219	137.887	-67.377	43.047	137.337	-67.377	0.172	0.55	0	0.576
0.857	144.402	-61.516	0.854	143.922	-61.516	0.003	0.479	0	0.479
-123.788	-55.129	-62.793	-123.634	-55.06	-62.793	-0.154	-0.069	0	-0.169
-130.197	-38.061	-68.558	-129.903	-37.975	-68.558	-0.294	-0.086	0	-0.306
-134.15	-20.246	-62.81	-133.825	-20.197	-62.81	-0.326	-0.049	0	-0.329
-135.594	-2.061	-68.577	-135.324	-2.057	-68.577	-0.269	-0.004	0	-0.269
-134.499	16.141	-62.83	-134.376	16.127	-62.83	-0.123	0.015	0	-0.124
-131.004	34.019	-68.599	-130.995	34.017	-68.599	-0.008	0.002	0	-0.009
-125.189	51.277	-62.851	-125.242	51.298	-62.851	0.052	-0.021	0	0.056
-117.136	67.598	-68.62	-117.221	67.647	-68.62	0.085	-0.049	0	0.098
-106.909	82.647	-62.872	-107.075	82.776	-62.872	0.166	-0.129	0	0.21
-94.763	96.17	-68.639	-94.992	96.403	-68.639	0.229	-0.232	0	0.326
-80.954	107.988	-62.89	-81.18	108.29	-62.89	0.226	-0.302	0	0.378
-65.714	117.872	-68.657	-65.903	118.211	-68.657	0.189	-0.339	0	0.388
-49.324	125.733	-62.906	-49.425	125.992	-62.906	0.102	-0.259	0	0.278
-32.004	131.275	-68.671	-32.056	131.489	-68.671	0.052	-0.214	0	0.22

-14.091	134.51	-62.918		-14.101	134.603	-62.918		0.01	-0.094	0		0.094
38.631	129.947	-71.562		38.566	129.729	-71.562		0.065	0.219	0		-0.228
74.68	112.764	-62.922		74.729	112.838	-62.922		-0.049	-0.075	0		0.09
104.314	86.067	-71.55		104.394	86.133	-71.55		-0.079	-0.066	0		0.103
124.909	51.921	-62.898		124.973	51.948	-62.898		-0.064	-0.027	0		0.07
134.817	13.258	-71.514		134.69	13.246	-71.514		0.126	0.012	0		-0.127
132.809	-26.607	-62.857		132.703	-26.586	-62.857		0.106	-0.021	0		-0.108
119.285	-64.168	-71.469		119.189	-64.117	-71.469		0.096	-0.052	0		-0.109
95.321	-96.043	-62.81		95.338	-96.06	-62.81		-0.017	0.017	0		0.024
63.024	-119.322	-71.428		63.21	-119.672	-71.428		-0.185	0.351	0		0.397
25.474	-132.187	-62.777		25.611	-132.895	-62.777		-0.136	0.708	0		0.721
-14.097	-133.548	-71.406		-14.207	-134.592	-71.406		0.11	1.044	0		1.05
-52.647	-124.26	-62.767		-52.798	-124.617	-62.767		0.151	0.357	0		0.388
-86.699	-103.709	-71.409		-86.804	-103.836	-71.409		0.106	0.126	0		0.165
-22.37	-82.742	-119.594		-22.37	-82.742	-119.18		0	0	-0.414		-0.414
-1.386	-82.753	-119.398		-1.386	-82.753	-119.18		0	0	-0.218		-0.218
19.597	-82.763	-119.395		19.597	-82.763	-119.18		0	0	-0.215		-0.215
61.576	-59.177	-119.444		61.576	-59.177	-119.18		0	0	-0.264		-0.264
40.591	-59.166	-119.512		40.591	-59.166	-119.18		0	0	-0.332		-0.332
-43.342	-59.123	-119.57		-43.342	-59.123	-119.18		0	0	-0.39		-0.39
-64.326	-59.112	-119.517		-64.326	-59.112	-119.18		0	0	-0.337		-0.337
-64.313	-35.505	-119.563		-64.313	-35.505	-119.18		0	0	-0.383		-0.383
61.588	-35.57	-119.432		61.588	-35.57	-119.18		0	0	-0.252		-0.252
82.572	-35.581	-119.438		82.572	-35.581	-119.18		0	0	-0.258		-0.258
82.584	-11.974	-119.351		82.584	-11.974	-119.18		0	0	-0.171		-0.171
82.596	11.635	-119.396		82.596	11.635	-119.18		0	0	-0.216		-0.216
82.608	35.242	-119.437		82.608	35.242	-119.18		0	0	-0.257		-0.257
61.624	35.254	-119.44		61.624	35.254	-119.18		0	0	-0.26		-0.26
-64.277	35.318	-119.561		-64.277	35.318	-119.18		0	0	-0.381		-0.381
-64.265	58.925	-119.557		-64.265	58.925	-119.18		0	0	-0.377		-0.377
-43.281	58.914	-119.589		-43.281	58.914	-119.18		0	0	-0.409		-0.409
40.654	58.871	-119.457		40.654	58.871	-119.18		0	0	-0.277		-0.277
61.637	58.861	-119.453		61.637	58.861	-119.18		0	0	-0.273		-0.273
19.682	82.491	-119.527		19.682	82.491	-119.18		0	0	-0.347		-0.347
-1.302	82.501	-119.657		-1.302	82.501	-119.18		0	0	-0.477		-0.477
-22.285	82.512	-119.593		-22.285	82.512	-119.18		0	0	-0.413		-0.413
-63.3	-23.843	-122.148		-63.327	-23.853	-122.148		0.026	0.01	0		0.028
-67.743	2.936	-131.527		-67.607	2.93	-131.527		-0.137	0.006	0		-0.137
-61.199	29.365	-122.177		-61.01	29.275	-122.177		-0.189	0.09	0		-0.209
-44.724	51.08	-131.556		-44.577	50.913	-131.556		-0.146	0.167	0		-0.222
-20.998	64.527	-122.205		-20.94	64.349	-122.205		-0.058	0.179	0		-0.188

16.279	66.532	-131.577	16.083	65.731	-131.577	0.196	0.801	0	-0.825
41.021	54.558	-122.211	40.667	54.087	-122.211	0.354	0.47	0	-0.589
59.131	33.976	-131.567	58.674	33.714	-131.567	0.457	0.263	0	-0.527
67.463	7.946	-122.191	67.205	7.915	-122.191	0.257	0.03	0	-0.259
64.892	-19.14	-131.539	64.905	-19.144	-131.539	-0.014	0.004	0	0.014
51.886	-42.869	-122.16	52.168	-43.102	-122.16	-0.282	0.233	0	0.366
30.703	-59.418	-131.511	31.065	-60.118	-131.511	-0.362	0.701	0	0.789
4.91	-66.479	-122.138	4.985	-67.486	-122.138	-0.074	1.007	0	1.01
-21.682	-63.427	-131.498	-21.889	-64.032	-131.498	0.207	0.606	0	0.64
-44.989	-50.019	-122.137	-45.253	-50.313	-122.137	0.264	0.294	0	0.395
-70.623	-90.103	-134.229	-70.686	-90.183	-133.99	0.063	0.08	-0.238	-0.259
-7.976	-111.465	-133.534	-7.999	-111.779	-132.863	0.022	0.314	-0.671	-0.741
27.778	-110.834	-134.386	27.825	-111.021	-133.935	-0.047	0.187	-0.451	-0.491
102.189	-49.402	-133.578	102.208	-49.411	-133.53	-0.019	0.009	-0.048	-0.053
97.955	9.201	-124.471	97.86	9.192	-124.598	0.095	0.009	0.128	0.159
86.849	81.403	-135.614	86.822	81.378	-135.717	0.027	0.025	0.104	0.11
23.813	106	-130.763	23.778	105.841	-131.07	0.036	0.16	0.307	0.348
-70.795	88.239	-133.421	-70.811	88.259	-133.364	0.016	-0.02	-0.057	-0.063
-108.038	-1.976	-130.832	-108.033	-1.976	-130.841	-0.005	0	0.009	0.011
-25.099	117.286	-110.847	-24.793	117.335	-110.764	-0.306	-0.049	-0.083	-0.321
47.471	111.954	-128.312	47.671	111.895	-128.3	-0.2	0.06	-0.012	-0.209
108.617	30.235	-120.435	108.741	29.899	-120.401	-0.124	0.336	-0.034	-0.359
115.25	-35.546	-107.817	114.911	-35.826	-107.373	0.339	0.281	-0.444	-0.625
69.027	-91.141	-123.164	68.446	-91.663	-123.095	0.58	0.522	-0.069	-0.783
6.802	-108.331	-114.655	6.812	-108.342	-114.674	-0.01	0.011	0.02	0.025
-29.354	-114.904	-118.411	-29.279	-114.917	-118.418	-0.075	0.013	0.007	0.077
-84.31	-73.275	-119.114	-84.148	-73.439	-119.143	-0.162	0.163	0.028	0.232
-100.101	-15.181	-119.923	-99.89	-15.317	-119.665	-0.211	0.135	-0.258	-0.36
-96.717	49.151	-115.934	-96.573	49.312	-115.799	-0.144	-0.162	-0.135	-0.255
6.147	114.902	-111.631	5.828	114.76	-111.437	0.319	0.142	-0.194	-0.399
-55.854	96.238	-112.579	-55.801	96.3	-112.605	-0.053	-0.062	0.026	0.086
-109.29	13.33	-117.535	-109.299	13.61	-117.556	0.009	-0.28	0.02	0.281
-102.932	-53.67	-114.236	-102.92	-53.686	-114.235	-0.012	0.016	-0.002	-0.02
76.553	-88.592	-112.219	76.011	-89.284	-112.343	0.541	0.692	0.123	0.887
100.673	-29.223	-117.697	100.733	-29.498	-117.864	-0.061	0.275	0.167	0.327
107.074	36.296	-113.374	107.207	36.104	-113.439	-0.133	0.192	0.064	0.242
37.178	101.753	-118.678	37.16	101.757	-118.677	0.018	-0.004	-0.001	-0.018
-77.035	69.321	-119.36	-77.06	69.261	-119.337	0.025	0.06	-0.023	-0.069
23.516	222.703	-63.777	23.532	222.859	-63.782	-0.016	-0.156	0.004	0.157
90.864	203.731	-71.078	91.057	204.165	-71.136	-0.193	-0.433	0.058	0.478
149.597	165.893	-63.752	150.076	166.425	-63.771	-0.479	-0.531	0.02	0.716

193.371	111.416	-71.05	193.703	111.607	-71.096	-0.331	-0.191	0.046	0.385
219.079	46.349	-63.71	219.247	46.384	-63.715	-0.168	-0.036	0.005	0.172
222.285	-23.587	-71.016	222.316	-23.59	-71.019	-0.031	0.003	0.004	0.031
204.542	-91.301	-63.63	204.641	-91.345	-63.633	-0.098	0.044	0.003	0.108
165.898	-149.651	-70.912	166.011	-149.753	-70.93	-0.113	0.102	0.018	0.153
111.692	-193.814	-63.545	111.896	-194.169	-63.556	-0.205	0.355	0.01	0.41
46.173	-217.978	-70.773	46.332	-218.729	-70.864	-0.159	0.751	0.091	0.773
-23.409	-221.56	-63.481	-23.547	-222.864	-63.512	0.138	1.305	0.032	1.313
-90.825	-203.779	-70.792	-91.021	-204.219	-70.848	0.196	0.44	0.057	0.485
-149.925	-166.419	-63.523	-150	-166.502	-63.526	0.075	0.083	0.003	0.112
-222.006	-30.056	-63.589	-222.077	-30.065	-63.591	0.072	0.01	0.002	0.072
-213.926	64.253	-70.967	-214.118	64.31	-70.991	0.192	-0.058	0.024	0.202
-168.335	147.112	-63.69	-168.742	147.468	-63.704	0.408	-0.356	0.014	0.541
-92.065	202.832	-71.003	-92.398	203.566	-71.101	0.333	-0.734	0.098	0.812
-196.269	-85.611	-99.726	-196.378	-85.659	-99.791	0.109	0.047	0.066	0.135
-212.284	-6.423	-102.909	-212.313	-6.424	-102.928	0.029	0.001	0.018	0.035
-185.703	109.359	-97.234	-185.767	109.397	-97.272	0.065	-0.038	0.038	0.084
-96.092	189.731	-102.023	-96.186	189.917	-102.148	0.094	-0.186	0.125	0.243
37.373	210.668	-101.279	37.301	210.257	-101.038	0.073	0.411	-0.242	-0.482
153.03	151.376	-97.798	153.066	151.412	-97.824	-0.036	-0.036	0.026	0.057
206.88	-67.143	-93.051	206.939	-67.162	-93.078	-0.058	0.019	0.027	0.067
120.029	-182.505	-89.83	120.248	-182.838	-89.984	-0.219	0.333	0.154	0.427
-125.935	-170.633	-103.094	-126.035	-170.769	-103.199	0.1	0.136	0.105	0.199
209.626	11.075	-71.006	209.645	11.008	-71.001	-0.019	0.067	-0.004	-0.069
141.145	-157.818	-73.075	140.818	-158.275	-73.041	0.327	0.457	-0.034	-0.563
-35.909	-208.523	-76.365	-36.146	-208.535	-76.353	0.237	0.012	-0.013	-0.238
-208.531	-43.164	-75.804	-208.549	-43.123	-75.801	0.018	-0.041	-0.002	-0.045
-117.426	178.917	-77.547	-117.096	179.254	-77.522	-0.33	-0.337	-0.025	-0.472
66.525	199.322	-75.785	66.64	199.31	-75.779	-0.115	0.012	-0.006	-0.115
63.643	204.075	-77.746	64.252	203.997	-77.735	-0.609	0.079	-0.01	0.614
-63.665	205.839	-77.911	-62.646	206.359	-77.887	-1.019	-0.52	-0.024	1.144
-184.365	-105.016	-79.93	-184.58	-104.754	-79.927	0.214	-0.262	-0.003	0.339
-94.385	-195.227	-70.762	-94.558	-195.182	-70.755	0.174	-0.046	-0.008	0.18
89.853	-189.115	-71.62	89.173	-189.612	-71.604	0.68	0.497	-0.017	0.842
203.972	-47.893	-74.975	203.937	-48.559	-74.968	0.035	0.666	-0.007	0.667
196.831	75.883	-77.32	197.078	75.471	-77.315	-0.247	0.412	-0.004	0.48
-66.848	-253.513	0.124	-66.848	-253.513	0	0	0	0.124	0.124
-40.165	-253.526	-0.026	-40.165	-253.526	0	0	0	-0.026	-0.026
-13.483	-253.539	-0.079	-13.483	-253.539	0	0	0	-0.079	-0.079
13.199	-253.553	-0.043	13.199	-253.553	0	0	0	-0.043	-0.043
39.881	-253.567	-0.022	39.881	-253.567	0	0	0	-0.022	-0.022

66.564	-253.58	0.002	66.564	-253.58	0	0	0	0.002	0.002
119.943	-226.924	0.074	119.943	-226.924	0	0	0	0.074	0.074
93.259	-226.911	0.084	93.259	-226.911	0	0	0	0.084	0.084
-93.517	-226.814	0.114	-93.517	-226.814	0	0	0	0.114	0.114
-120.199	-226.801	0.15	-120.199	-226.801	0	0	0	0.15	0.15
-173.552	-200.09	0.23	-173.552	-200.09	0	0	0	0.23	0.23
-146.868	-200.105	0.179	-146.868	-200.105	0	0	0	0.179	0.179
146.64	-200.256	0.148	146.64	-200.256	0	0	0	0.148	0.148
173.321	-200.27	0.188	173.321	-200.27	0	0	0	0.188	0.188
200.017	-173.6	0.297	200.017	-173.6	0	0	0	0.297	0.297
173.334	-173.586	0.262	173.334	-173.586	0	0	0	0.262	0.262
-173.537	-173.408	0.238	-173.537	-173.408	0	0	0	0.238	0.238
-200.221	-173.395	0.277	-200.221	-173.395	0	0	0	0.277	0.277
-200.205	-146.711	0.246	-200.205	-146.711	0	0	0	0.246	0.246
200.03	-146.918	0.373	200.03	-146.918	0	0	0	0.373	0.373
226.728	-120.248	0.464	226.728	-120.248	0	0	0	0.464	0.464
-226.875	-120.014	0.409	-226.875	-120.014	0	0	0	0.409	0.409
-226.86	-93.331	0.42	-226.86	-93.331	0	0	0	0.42	0.42
226.741	-93.567	0.442	226.741	-93.567	0	0	0	0.442	0.442
253.437	-66.896	0.541	253.437	-66.896	0	0	0	0.541	0.541
-253.53	-66.635	0.526	-253.53	-66.635	0	0	0	0.526	0.526
-253.515	-39.952	0.543	-253.515	-39.952	0	0	0	0.543	0.543
253.451	-40.214	0.551	253.451	-40.214	0	0	0	0.551	0.551
253.465	-13.53	0.546	253.465	-13.53	0	0	0	0.546	0.546
-253.503	-13.269	0.571	-253.503	-13.269	0	0	0	0.571	0.571
-253.487	13.414	0.605	-253.487	13.414	0	0	0	0.605	0.605
253.479	13.151	0.549	253.479	13.151	0	0	0	0.549	0.549
253.492	39.836	0.482	253.492	39.836	0	0	0	0.482	0.482
-253.475	40.097	0.504	-253.475	40.097	0	0	0	0.504	0.504
-253.46	66.779	0.514	-253.46	66.779	0	0	0	0.514	0.514
253.506	66.517	0.386	253.506	66.517	0	0	0	0.386	0.386
226.836	93.214	0.269	226.836	93.214	0	0	0	0.269	0.269
-226.765	93.448	0.348	-226.765	93.448	0	0	0	0.348	0.348
-226.75	120.131	0.388	-226.75	120.131	0	0	0	0.388	0.388
226.851	119.896	0.237	226.851	119.896	0	0	0	0.237	0.237
200.181	146.593	0.124	200.181	146.593	0	0	0	0.124	0.124
-200.055	146.8	0.262	-200.055	146.8	0	0	0	0.262	0.262
-200.04	173.482	0.264	-200.04	173.482	0	0	0	0.264	0.264
-173.358	173.468	0.115	-173.358	173.468	0	0	0	0.115	0.115
173.514	173.289	-0.004	173.514	173.289	0	0	0	-0.004	-0.004
200.196	173.275	-0.01	200.196	173.275	0	0	0	-0.01	-0.01

173.526	199.972	-0.077	173.526	199.972	0	0	0	-0.077	-0.077
146.845	199.987	-0.108	146.845	199.987	0	0	0	-0.108	-0.108
-146.663	200.138	0.072	-146.663	200.138	0	0	0	0.072	0.072
-173.345	200.151	0.109	-173.345	200.151	0	0	0	0.109	0.109
-119.965	226.807	-0.013	-119.965	226.807	0	0	0	-0.013	-0.013
-93.282	226.793	-0.057	-93.282	226.793	0	0	0	-0.057	-0.057
93.494	226.695	-0.143	93.494	226.695	0	0	0	-0.143	-0.143
120.178	226.681	-0.138	120.178	226.681	0	0	0	-0.138	-0.138
66.824	253.393	-0.14	66.824	253.393	0	0	0	-0.14	-0.14
40.142	253.406	-0.227	40.142	253.406	0	0	0	-0.227	-0.227
13.459	253.421	-0.117	13.459	253.421	0	0	0	-0.117	-0.117
-13.223	253.435	-0.165	-13.223	253.435	0	0	0	-0.165	-0.165
-39.906	253.448	-0.126	-39.906	253.448	0	0	0	-0.126	-0.126
-66.588	253.462	-0.091	-66.588	253.462	0	0	0	-0.091	-0.091

*Appendix L      Casting - Statistical  
CMM Raw Data (3D-  
Tol Data)*

### 3D-Tol Data from CMM for Pattern f

MEAS X	MEAS Y	MEAS Z	CAD X	CAD Y	CAD Z	DIF X	DIF Y	DIF Z	TOT DIF
-230.66	-54.371	-6.161	-232.985	-54.919	-6.161	2.325	0.548	0	2.388
-236.96	15.694	-6.16	-238.847	15.819	-6.16	1.887	-0.125	0	1.891
-222.244	84.612	-6.161	-223.706	85.168	-6.161	1.462	-0.556	0	1.564
-187.784	146.161	-6.162	-188.895	147.026	-6.162	1.111	-0.865	0	1.408
-136.636	194.761	-6.162	-137.475	195.956	-6.162	0.839	-1.195	0	1.46
-73.413	225.952	-6.16	-73.967	227.655	-6.16	0.553	-1.703	0	1.791
1.308	237.05	-6.161	1.321	239.366	-6.161	-0.013	-2.317	0	2.317
70.892	226.646	-6.161	71.458	228.455	-6.161	-0.566	-1.809	0	1.895
134.342	196.048	-6.161	135.308	197.458	-6.161	-0.966	-1.41	0	1.709
185.891	148.001	-6.16	187.266	149.095	-6.16	-1.375	-1.095	0	1.758
220.738	86.833	-6.16	222.755	87.626	-6.16	-2.017	-0.793	0	2.167
236.25	18.267	-6.159	238.658	18.453	-6.159	-2.407	-0.186	0	2.415
230.917	-51.752	-6.159	233.576	-52.348	-6.159	-2.659	0.596	0	2.725
205.155	-116.948	-6.158	207.955	-118.544	-6.158	-2.8	1.596	0	3.223
161.399	-171.496	-6.159	164.051	-174.314	-6.159	-2.652	2.818	0	3.87
103.764	-210.788	-6.159	105.719	-214.759	-6.159	-1.955	3.972	0	4.427
37.482	-232.543	-6.159	38.091	-236.32	-6.159	-0.609	3.777	0	3.826
-32.335	-233.185	-6.159	-32.878	-237.101	-6.159	0.543	3.917	0	3.954
-99.125	-213.081	-6.158	-100.964	-217.035	-6.158	1.84	3.954	0	4.361
-157.716	-175.161	-6.159	-160.17	-177.887	-6.159	2.454	2.726	0	3.668
-226.531	-53.395	-19.219	-228.464	-53.85	-20.365	1.932	0.455	1.146	2.292
-230.387	15.261	-23.517	-231.893	15.361	-24.389	1.506	-0.1	0.871	1.743
-218.128	83.045	-19.605	-219.362	83.515	-20.368	1.234	-0.47	0.763	1.525
-182.559	142.094	-23.774	-183.396	142.746	-24.387	0.838	-0.652	0.613	1.226
-134.171	191.244	-19.726	-134.807	192.151	-20.366	0.636	-0.907	0.64	1.28
-71.391	219.728	-23.598	-71.814	221.028	-24.387	0.423	-1.3	0.789	1.579
1.286	233.188	-19.48	1.294	234.721	-20.365	-0.008	-1.532	0.885	1.769
68.954	220.456	-23.572	69.376	221.805	-24.388	-0.422	-1.349	0.816	1.632
131.899	192.48	-19.565	132.683	193.624	-20.366	-0.784	-1.144	0.801	1.602
180.676	143.848	-23.545	181.816	144.755	-24.386	-1.14	-0.907	0.841	1.682
216.74	85.261	-19.314	218.432	85.927	-20.363	-1.692	-0.665	1.05	2.099
229.768	17.764	-23.262	231.711	17.915	-24.387	-1.943	-0.15	1.125	2.25
226.819	-50.83	-19.051	229.042	-51.329	-20.367	-2.223	0.498	1.316	2.631
199.679	-113.825	-22.912	201.901	-115.092	-24.389	-2.223	1.267	1.477	2.954
158.846	-168.787	-18.668	160.864	-170.931	-20.368	-2.018	2.144	1.7	3.4
101.196	-205.579	-22.504	102.638	-208.508	-24.389	-1.442	2.929	1.885	3.77
36.918	-229.014	-18.776	37.356	-231.732	-20.366	-0.438	2.718	1.589	3.179
-31.551	-227.526	-22.83	-31.921	-230.199	-24.388	0.371	2.673	1.558	3.116
-97.664	-209.947	-18.533	-99.002	-212.824	-20.365	1.338	2.877	1.832	3.664
-153.705	-170.706	-22.828	-155.508	-172.71	-24.384	1.804	2.003	1.556	3.112
-219.662	-51.773	-40.734	-221.681	-52.249	-40.734	2.019	0.476	0	2.074
-225.654	14.947	-35.202	-227.257	15.053	-35.202	1.603	-0.106	0	1.607

-212.048	80.731	-40.736	-212.851	81.036	-40.736	0.803	-0.306	0	0.859
-179.106	139.405	-35.202	-179.73	139.891	-35.202	0.624	-0.486	0	0.791
-130.041	185.355	-40.736	-130.807	186.446	-40.736	0.765	-1.091	0	1.332
-69.834	214.939	-35.203	-70.377	216.609	-35.203	0.543	-1.67	0	1.756
65.027	216.495	-35.203	65.518	218.128	-35.203	-0.491	-1.633	0	1.705
125.562	188.337	-40.736	126.338	189.502	-40.736	-0.776	-1.165	0	1.4
175.043	143.46	-35.202	176.153	144.37	-35.202	-1.11	-0.909	0	1.435
209.119	86.043	-40.733	210.623	86.661	-40.733	-1.504	-0.619	0	1.627
224.702	21.212	-35.201	226.747	21.405	-35.201	-2.045	-0.193	0	2.054
220.766	-45.234	-40.734	223.12	-45.716	-40.734	-2.353	0.482	0	2.402
197.559	-107.496	-35.2	200.057	-108.856	-35.2	-2.498	1.359	0	2.844
157.203	-160.103	-40.733	159.569	-162.512	-40.733	-2.366	2.409	0	3.376
103.361	-198.524	-35.199	105.179	-202.014	-35.199	-1.817	3.491	0	3.935
40.995	-220.485	-40.733	41.633	-223.918	-40.733	-0.638	3.432	0	3.491
-25.182	-223.125	-35.199	-25.543	-226.318	-35.199	0.36	3.193	0	3.214
-89.034	-205.63	-40.733	-90.495	-209.005	-40.733	1.461	3.375	0	3.678
-145.41	-170.958	-35.199	-147.562	-173.487	-35.199	2.152	2.53	0	3.321
-76.771	-179.156	-59.677	-76.771	-179.156	-60.095	0	0	0.418	0.418
76.771	-179.154	-59.712	76.771	-179.154	-60.095	0	0	0.383	0.383
-179.132	-76.78	-59.325	-179.132	-76.78	-60.095	0	0	0.77	0.77
179.133	-76.78	-59.354	179.133	-76.78	-60.095	0	0	0.741	0.741
-179.132	76.78	-59.573	-179.132	76.78	-60.095	0	0	0.522	0.522
179.132	76.78	-59.214	179.132	76.78	-60.095	0	0	0.881	0.881
-76.771	179.154	-59.887	-76.771	179.154	-60.095	0	0	0.208	0.208
76.771	179.154	-59.74	76.771	179.154	-60.095	0	0	0.355	0.355
-55.515	-129.534	-59.917	-55.515	-129.534	-60.095	0	0	0.178	0.178
55.515	-129.533	-59.919	55.515	-129.533	-60.095	0	0	0.176	0.176
-129.533	-55.515	-59.788	-129.533	-55.515	-60.095	0	0	0.307	0.307
129.534	-55.514	-59.733	129.534	-55.514	-60.095	0	0	0.362	0.362
-129.532	55.513	-59.823	-129.532	55.513	-60.095	0	0	0.272	0.272
129.533	55.514	-59.582	129.533	55.514	-60.095	0	0	0.513	0.513
-55.514	129.532	-59.985	-55.514	129.532	-60.095	0	0	0.11	0.11
55.515	129.533	-59.803	55.515	129.533	-60.095	0	0	0.292	0.292
41.287	169.183	-84.692	41.358	169.477	-85.625	-0.072	-0.294	0.932	0.98
45.076	184.703	-65.325	45.423	186.127	-65.557	-0.348	-1.424	0.232	1.484
114.169	152.295	-65.36	114.92	153.297	-65.558	-0.751	-1.002	0.198	1.267
104.428	139.302	-84.539	104.639	139.584	-85.624	-0.211	-0.282	1.085	1.141
150.706	87.013	-84.306	151.077	87.227	-85.625	-0.371	-0.214	1.319	1.386
164.595	95.029	-65.314	165.922	95.794	-65.557	-1.326	-0.766	0.242	1.55
188.372	22.651	-65.264	190.219	22.873	-65.558	-1.847	-0.222	0.295	1.884
172.754	20.775	-84.233	173.203	20.829	-85.624	-0.449	-0.054	1.392	1.464
167.006	-48.793	-84.204	167.449	-48.922	-85.625	-0.443	0.129	1.421	1.495
181.684	-53.076	-65.191	183.903	-53.724	-65.557	-2.219	0.648	0.366	2.34
145.814	-119.897	-65.111	147.986	-121.683	-65.556	-2.172	1.786	0.445	2.847
134.366	-110.483	-84.108	134.747	-110.796	-85.625	-0.381	0.313	1.517	1.595

80.156	-154.447	-84.263	80.36	-154.839	-85.625	-0.204	0.393	1.362	1.432
86.87	-167.388	-65.08	88.253	-170.053	-65.556	-1.383	2.665	0.475	3.04
14.127	-188.548	-65.161	14.315	-191.054	-65.559	-0.188	2.506	0.398	2.544
13.02	-173.746	-84.953	13.036	-173.963	-85.625	-0.016	0.217	0.671	0.706
-56.255	-164.712	-84.401	-56.384	-165.088	-85.624	0.128	0.376	1.223	1.286
-61.077	-178.826	-65.14	-61.924	-181.307	-65.555	0.847	2.481	0.415	2.654
-126.382	-140.362	-65.127	-128.198	-142.379	-65.556	1.816	2.017	0.43	2.748
-116.511	-129.402	-84.623	-116.729	-129.643	-85.625	0.218	0.242	1.002	1.053
-177.294	-66.538	-65.194	-179.375	-67.319	-65.545	2.081	0.781	0.351	2.25
-163.049	-61.195	-84.707	-163.328	-61.3	-85.624	0.279	0.105	0.917	0.964
-174.055	7.817	-84.927	-174.28	7.827	-85.623	0.226	-0.01	0.695	0.731
-189.678	8.518	-65.274	-191.398	8.596	-65.546	1.72	-0.077	0.272	1.743
-171.449	82.569	-65.341	-172.616	83.132	-65.546	1.167	-0.562	0.204	1.312
-157.035	75.627	-85.137	-157.177	75.695	-85.623	0.142	-0.069	0.486	0.511
-114.707	131.294	-85.272	-114.782	131.38	-85.622	0.075	-0.086	0.351	0.369
-125.156	143.25	-65.329	-126.057	144.281	-65.545	0.9	-1.031	0.216	1.385
-58.644	180.495	-65.26	-59.203	182.215	-65.545	0.559	-1.72	0.285	1.831
-53.856	165.749	-85.081	-53.911	165.917	-85.623	0.054	-0.168	0.542	0.57
-23.332	-163.316	-86.339	-23.332	-163.316	-86.86	0	0	0.521	0.521
-0.001	-163.316	-86.943	-0.001	-163.316	-86.86	0	0	-0.083	-0.083
23.33	-163.315	-86.96	23.33	-163.315	-86.86	0	0	-0.1	-0.1
69.992	-139.984	-86.787	69.992	-139.984	-86.86	0	0	0.073	0.073
-69.994	-139.984	-86.852	-69.994	-139.984	-86.86	0	0	0.008	0.008
-116.656	-116.653	-86.851	-116.656	-116.653	-86.86	0	0	0.009	0.009
116.654	-116.654	-86.192	116.654	-116.654	-86.86	0	0	0.668	0.668
-139.988	-69.992	-87.028	-139.988	-69.992	-86.86	0	0	-0.168	-0.168
139.985	-69.992	-86.112	139.985	-69.992	-86.86	0	0	0.748	0.748
-163.317	-23.329	-86.797	-163.317	-23.329	-86.86	0	0	0.063	0.063
163.316	-23.329	-85.868	163.316	-23.329	-86.86	0	0	0.992	0.992
163.315	0.001	-85.893	163.315	0.001	-86.86	0	0	0.967	0.967
-163.318	0.001	-86.761	-163.318	0.001	-86.86	0	0	0.099	0.099
-163.318	23.332	-87.015	-163.318	23.332	-86.86	0	0	-0.155	-0.155
163.316	23.332	-85.843	163.316	23.332	-86.86	0	0	1.017	1.017
-139.987	69.994	-86.96	-139.987	69.994	-86.86	0	0	-0.1	-0.1
139.984	69.994	-85.876	139.984	69.994	-86.86	0	0	0.984	0.984
-116.656	116.656	-87.032	-116.656	116.656	-86.86	0	0	-0.172	-0.172
116.654	116.656	-85.956	116.654	116.656	-86.86	0	0	0.904	0.904
69.991	139.985	-86.157	69.991	139.985	-86.86	0	0	0.703	0.703
-69.994	139.987	-87.205	-69.994	139.987	-86.86	0	0	-0.345	-0.345
-23.332	163.318	-87.062	-23.332	163.318	-86.86	0	0	-0.202	-0.202
0	163.318	-87.302	0	163.318	-86.86	0	0	-0.442	-0.442
23.331	163.318	-86.277	23.331	163.318	-86.86	0	0	0.583	0.583
-98.434	-109.319	-83.682	-98.682	-109.594	-83.311	0.248	0.276	-0.371	-0.525
-103.148	-114.558	-86.699	-103.146	-114.556	-86.711	-0.001	-0.001	0.012	0.012
-65.046	-139.823	-86.29	-65.018	-139.762	-86.71	-0.028	-0.06	0.42	0.426

-61.984	-133.25	-83.824		-62.201	-133.716	-83.31		0.217	0.466	-0.514		-0.727
-20.199	-145.67	-83.724		-20.256	-146.078	-83.311		0.057	0.409	-0.413		-0.584
-21.182	-152.749	-86.313		-21.174	-152.686	-86.711		-0.009	-0.062	0.398		0.403
24.527	-152.145	-86.944		24.533	-152.182	-86.71		-0.006	0.037	-0.234		-0.237
23.382	-145.047	-83.864		23.47	-145.595	-83.31		-0.088	0.548	-0.555		-0.785
64.822	-131.674	-84.024		65.137	-132.313	-83.312		-0.314	0.639	-0.712		-1.007
68.105	-138.338	-86.424		68.085	-138.297	-86.711		0.02	-0.041	0.286		0.29
105.687	-112.293	-86.35		105.647	-112.252	-86.711		0.039	-0.042	0.361		0.366
100.626	-106.918	-83.959		101.072	-107.392	-83.309		-0.446	0.474	-0.65		-0.92
127.683	-72.779	-83.818		128.124	-73.03	-83.311		-0.441	0.251	-0.507		-0.718
133.994	-76.381	-86.173		133.92	-76.339	-86.711		0.074	-0.042	0.538		0.545
150.521	-33.734	-86.033		150.416	-33.71	-86.711		0.105	-0.023	0.677		0.686
143.597	-32.181	-83.626		143.905	-32.25	-83.31		-0.308	0.069	-0.316		-0.447
146.905	11.357	-83.438		147.034	11.367	-83.308		-0.129	-0.01	-0.13		-0.184
153.814	11.892	-85.953		153.695	11.883	-86.711		0.12	0.009	0.759		0.768
143.567	56.477	-85.892		143.446	56.429	-86.71		0.121	0.047	0.818		0.828
137.304	54.012	-83.242		137.239	53.987	-83.311		0.065	0.025	0.07		0.098
115.488	91.954	-83.159		115.37	91.86	-83.309		0.118	0.094	0.15		0.213
120.693	96.093	-85.919		120.595	96.015	-86.711		0.098	0.078	0.792		0.801
87.195	127.246	-86.038		87.135	127.159	-86.711		0.06	0.088	0.673		0.681
83.406	121.715	-83.232		83.362	121.652	-83.309		0.044	0.064	0.077		0.109
44.013	140.715	-83.349		44.024	140.751	-83.311		-0.011	-0.037	-0.039		-0.054
46.042	147.202	-86.165		46.017	147.119	-86.711		0.026	0.083	0.546		0.553
0.067	154.152	-86.66		0	154.144	-86.71		0.067	0.008	0.05		0.084
0.809	146.702	-84.086		0.813	147.475	-83.313		-0.004	-0.773	-0.773		-1.093
-45.381	139.661	-83.941		-45.575	140.258	-83.312		0.194	-0.598	-0.629		-0.889
-47.619	146.554	-87.066		-47.636	146.607	-86.711		0.017	-0.053	-0.355		-0.359
-88.5	126.144	-87.092		-88.535	126.193	-86.711		0.035	-0.049	-0.381		-0.385
-84.409	120.313	-83.818		-84.7	120.727	-83.311		0.291	-0.414	-0.506		-0.716
-116.114	90.375	-83.647		-116.379	90.582	-83.311		0.265	-0.206	-0.336		-0.475
-121.631	94.668	-86.828		-121.646	94.68	-86.711		0.015	-0.011	-0.117		-0.118
-144.051	54.84	-86.793		-144.063	54.845	-86.711		0.012	-0.005	-0.082		-0.083
-137.504	52.35	-83.65		-137.823	52.471	-83.309		0.319	-0.122	-0.342		-0.483
-146.668	9.716	-83.8		-147.154	9.748	-83.312		0.486	-0.032	-0.488		-0.69
-153.806	10.188	-86.774		-153.815	10.188	-86.711		0.01	-0.001	-0.063		-0.064
-150.038	-35.367	-86.719		-150.039	-35.367	-86.711		0.001	0	-0.008		-0.008
-143.063	-33.723	-83.804		-143.542	-33.836	-83.311		0.479	0.113	-0.493		-0.697
-44.188	136	-67.418		-44.474	136.881	-67.418		0.286	-0.881	0		-0.927
-82.392	117.434	-61.56		-82.662	117.819	-61.56		0.27	-0.385	0		-0.471
-113.255	88.156	-67.418		-113.574	88.405	-67.418		0.319	-0.248	0		-0.404
-134.211	51.098	-61.558		-134.506	51.211	-61.558		0.295	-0.112	0		-0.316
-142.971	9.469	-67.417		-143.61	9.511	-67.417		0.64	-0.042	0		-0.641
-140.065	-33.014	-60.581		-140.065	-33.014	-60.095		0	0	-0.486		0.486
-95.226	-105.763	-67.418		-96.303	-106.959	-67.418		1.077	1.196	0		-1.61
-59.96	-128.895	-61.56		-60.705	-130.497	-61.56		0.745	1.601	0		-1.766

-19.549	-140.989	-67.419		-19.767	-142.561	-67.419		0.218	1.572	0		-1.587
22.8	-141.421	-60.581		22.8	-141.421	-60.095		0	0	-0.486		0.486
62.664	-127.293	-67.418		63.567	-129.127	-67.418		-0.902	1.833	0		-2.043
97.871	-103.989	-60.581		97.871	-103.989	-60.095		0	0	-0.486		0.486
123.39	-70.335	-67.419		125.038	-71.274	-67.419		-1.648	0.939	0		-1.897
138.78	-31.1	-61.561		140.442	-31.472	-61.561		-1.662	0.372	0		-1.703
142.315	11.003	-67.419		143.497	11.094	-67.419		-1.182	-0.091	0		-1.186
134.002	52.717	-60.592		133.933	52.69	-60.095		0.069	0.027	-0.497		0.503
112.181	89.318	-67.417		112.595	89.648	-67.417		-0.414	-0.33	0		-0.53
81.079	118.323	-61.559		81.355	118.726	-61.559		-0.276	-0.403	0		-0.488
42.772	136.734	-67.418		42.968	137.361	-67.418		-0.196	-0.627	0		-0.657
0.791	143.476	-60.581		0.791	143.476	-60.095		0	0	-0.486		0.486
-122.565	-54.565	-62.974		-123.641	-55.044	-62.974		1.076	0.479	0		1.178
-128.95	-37.671	-68.731		-129.91	-37.952	-68.731		0.96	0.28	0		1
-133.035	-20.05	-62.973		-133.829	-20.169	-62.973		0.794	0.12	0		0.803
-134.708	-2.016	-68.732		-135.325	-2.025	-68.732		0.617	0.009	0		0.617
-133.841	16.095	-62.975		-134.372	16.159	-62.975		0.531	-0.064	0		0.535
-130.574	33.946	-68.732		-130.986	34.053	-68.732		0.412	-0.107	0		0.426
-124.958	51.212	-62.976		-125.231	51.324	-62.976		0.273	-0.112	0		0.295
-116.881	67.48	-68.732		-117.209	67.669	-68.732		0.328	-0.189	0		0.379
-106.741	82.542	-62.972		-107.063	82.791	-62.972		0.322	-0.249	0		0.407
-94.623	96.052	-68.733		-94.98	96.414	-68.733		0.357	-0.362	0		0.508
-80.845	107.845	-62.974		-81.179	108.291	-62.974		0.334	-0.446	0		0.557
-65.522	117.513	-68.732		-65.909	118.207	-68.732		0.387	-0.694	0		0.794
-49.088	125.085	-62.976		-49.442	125.986	-62.976		0.353	-0.901	0		0.967
-31.803	130.325	-68.733		-32.086	131.482	-68.733		0.282	-1.157	0		1.191
-14.001	133.219	-62.976		-14.146	134.599	-62.976		0.145	-1.38	0		1.388
38.227	128.886	-71.61		38.484	129.753	-71.61		-0.257	-0.867	0		0.905
74.28	112.358	-62.973		74.637	112.899	-62.973		-0.357	-0.541	0		0.648
103.836	85.855	-71.611		104.304	86.242	-71.611		-0.468	-0.387	0		0.607
124.249	51.815	-62.972		124.913	52.092	-62.972		-0.665	-0.277	0		0.72
133.647	13.317	-71.607		134.673	13.42	-71.607		-1.026	-0.102	0		1.031
131.262	-26.13	-62.971		132.736	-26.424	-62.971		-1.473	0.293	0		1.502
117.579	-63.057	-71.608		119.271	-63.964	-71.608		-1.692	0.907	0		1.92
93.933	-94.431	-62.971		95.446	-95.953	-62.971		-1.514	1.522	0		2.146
62.3	-117.665	-71.609		63.329	-119.609	-71.609		-1.029	1.944	0		2.2
25.336	-130.918	-62.97		25.715	-132.875	-62.97		-0.379	1.957	0		1.993
-13.946	-132.819	-71.608		-14.133	-134.6	-71.608		0.187	1.781	0		1.79
-51.994	-122.838	-62.971		-52.755	-124.635	-62.971		0.761	1.797	0		1.951
-85.728	-102.571	-71.609		-86.793	-103.845	-71.609		1.065	1.274	0		1.661
-22.303	-82.624	-120.791		-22.303	-82.624	-119.18		0	0	-1.611		-1.611
-1.318	-82.623	-121.256		-1.318	-82.623	-119.18		0	0	-2.076		-2.076
19.665	-82.624	-120.438		19.665	-82.624	-119.18		0	0	-1.258		-1.258
61.633	-59.016	-120.487		61.633	-59.016	-119.18		0	0	-1.307		-1.307
40.648	-59.017	-120.009		40.648	-59.017	-119.18		0	0	-0.829		-0.829

-43.285	-59.017	-119.9	-43.285	-59.017	-119.18	0	0	-0.72	-0.72
-64.269	-59.016	-120.767	-64.269	-59.016	-119.18	0	0	-1.587	-1.587
-64.269	-35.408	-120.262	-64.269	-35.408	-119.18	0	0	-1.082	-1.082
61.633	-35.408	-119.64	61.633	-35.408	-119.18	0	0	-0.46	-0.46
82.616	-35.409	-120.227	82.616	-35.409	-119.18	0	0	-1.047	-1.047
82.616	-11.801	-120.8	82.616	-11.801	-119.18	0	0	-1.62	-1.62
82.615	11.807	-120.943	82.615	11.807	-119.18	0	0	-1.763	-1.763
82.616	35.414	-120.835	82.616	35.414	-119.18	0	0	-1.655	-1.655
61.632	35.413	-119.962	61.632	35.413	-119.18	0	0	-0.782	-0.782
-64.269	35.413	-120.364	-64.269	35.413	-119.18	0	0	-1.184	-1.184
-64.269	59.022	-120.658	-64.269	59.022	-119.18	0	0	-1.478	-1.478
-43.284	59.022	-120.182	-43.284	59.022	-119.18	0	0	-1.002	-1.002
40.65	59.022	-119.977	40.65	59.022	-119.18	0	0	-0.797	-0.797
61.633	59.022	-120.711	61.633	59.022	-119.18	0	0	-1.531	-1.531
19.665	82.63	-121.393	19.665	82.63	-119.18	0	0	-2.213	-2.213
-1.318	82.629	-122.074	-1.318	82.629	-119.18	0	0	-2.894	-2.894
-22.302	82.629	-121.403	-22.302	82.629	-119.18	0	0	-2.223	-2.223
-63.153	-23.698	-122.302	-63.356	-23.775	-122.302	0.203	0.076	0	0.217
-67.7	3.042	-131.665	-67.602	3.037	-131.665	-0.099	0.004	0	-0.099
-60.804	29.281	-122.302	-60.969	29.36	-122.302	0.165	-0.079	0	0.183
-44.268	50.668	-131.666	-44.523	50.96	-131.666	0.255	-0.292	0	0.388
-20.76	63.892	-122.303	-20.911	64.358	-122.303	0.151	-0.466	0	0.49
16.011	65.611	-131.666	16.043	65.741	-131.666	-0.032	-0.13	0	0.134
40.504	54.029	-122.301	40.591	54.145	-122.301	-0.087	-0.116	0	0.145
58.509	33.779	-131.665	58.605	33.834	-131.665	-0.095	-0.055	0	0.11
66.879	8.041	-122.299	67.186	8.077	-122.299	-0.307	-0.037	0	0.309
64.523	-18.85	-131.662	64.955	-18.976	-131.662	-0.432	0.126	0	0.45
51.674	-42.491	-122.299	52.268	-42.98	-122.299	-0.594	0.489	0	0.769
30.79	-59.342	-131.663	31.166	-60.066	-131.663	-0.376	0.724	0	0.816
5.075	-67.735	-122.301	5.056	-67.481	-122.301	0.019	-0.255	0	-0.255
-21.794	-63.813	-131.664	-21.871	-64.038	-131.664	0.077	0.225	0	0.238
-45.052	-50.038	-122.299	-45.279	-50.289	-122.299	0.227	0.252	0	0.339
-70.628	-90.099	-134.104	-70.663	-90.144	-133.971	0.035	0.045	-0.133	-0.145
-7.911	-111.586	-133.169	-7.921	-111.739	-132.842	0.011	0.153	-0.327	-0.361
27.914	-110.884	-134.087	27.932	-110.954	-133.919	-0.018	0.07	-0.169	-0.184
102.22	-49.203	-133.761	102.309	-49.246	-133.538	-0.089	0.043	-0.223	-0.244
97.208	9.311	-125.604	97.915	9.378	-124.653	-0.708	-0.068	-0.952	-1.188
86.847	81.595	-135.647	86.817	81.567	-135.762	0.03	0.028	0.115	0.122
23.648	105.534	-132.017	23.749	105.986	-131.142	-0.101	-0.452	-0.875	-0.99
-70.771	88.291	-133.658	-70.84	88.376	-133.413	0.069	-0.086	-0.245	-0.268
-107.649	-1.889	-131.639	-108.07	-1.897	-130.86	0.42	0.007	-0.779	-0.885
-24.876	117.436	-110.838	-24.797	117.449	-110.817	-0.079	-0.013	-0.021	-0.083
47.635	112.057	-128.357	47.715	112.033	-128.353	-0.08	0.024	-0.005	-0.084
108.666	30.324	-120.515	108.815	29.919	-120.474	-0.149	0.405	-0.041	-0.433
114.72	-35.834	-107.192	114.85	-35.735	-107.364	-0.13	-0.098	0.172	0.237

68.708	-91.326	-123.282		68.386	-91.616	-123.244		0.322	0.29	-0.038		-0.435
6.522	-107.82	-114.155		6.827	-108.16	-114.768		-0.305	0.34	0.612		0.763
-29.336	-114.777	-118.602		-29.274	-114.787	-118.608		-0.062	0.01	0.006		0.063
-84.357	-73.073	-119.277		-84.085	-73.345	-119.323		-0.272	0.273	0.046		0.388
-99.462	-15.493	-119.335		-99.787	-15.285	-119.733		0.325	-0.208	0.397		0.554
-96.311	49.677	-115.661		-96.563	49.373	-115.887		0.251	0.303	0.227		0.455
5.477	114.747	-111.302		5.768	114.867	-111.463		-0.29	-0.119	0.161		0.353
-56.466	95.306	-111.947		-56.509	95.903	-112.723		0.042	-0.596	0.776		0.979
-109.281	13.749	-117.695		-109.277	13.601	-117.685		-0.005	0.147	-0.01		-0.148
-103.071	-53.331	-114.431		-102.838	-53.641	-114.401		-0.233	0.31	-0.03		-0.389
76.465	-88.611	-112.409		75.978	-89.228	-112.513		0.487	0.617	0.104		0.793
100.557	-28.373	-117.402		100.749	-29.427	-117.981		-0.191	1.055	0.579		1.218
106.764	36.919	-113.3		107.263	36.169	-113.524		-0.499	0.75	0.224		0.928
37.126	101.906	-118.735		37.184	101.894	-118.739		-0.058	0.012	0.003		0.059
-77.242	68.93	-119.269		-77.098	69.258	-119.388		-0.144	-0.328	0.119		0.378
23.218	220.906	-63.723		23.425	222.87	-63.778		-0.206	-1.965	0.054		1.976
90.325	202.867	-70.939		90.929	204.224	-71.12		-0.604	-1.357	0.181		1.496
149.039	165.52	-63.74		149.953	166.535	-63.778		-0.914	-1.015	0.038		1.367
192.222	110.978	-70.926		193.602	111.775	-71.12		-1.38	-0.797	0.194		1.605
217.493	46.227	-63.729		219.201	46.59	-63.777		-1.708	-0.363	0.048		1.747
220.193	-23.145	-70.858		222.327	-23.369	-71.119		-2.134	0.224	0.261		2.161
202.386	-90.112	-63.708		204.722	-91.153	-63.778		-2.337	1.04	0.07		2.559
163.868	-147.547	-70.749		166.132	-149.585	-71.12		-2.263	2.038	0.371		3.068
110.296	-191.051	-63.682		112.044	-194.078	-63.778		-1.747	3.027	0.096		3.496
45.785	-215.42	-70.717		46.475	-218.667	-71.121		-0.69	3.247	0.404		3.344
-23.112	-219.897	-63.696		-23.424	-222.87	-63.778		0.312	2.973	0.082		2.991
-89.674	-201.409	-70.746		-90.927	-204.224	-71.12		1.253	2.815	0.375		3.104
-148.219	-163.27	-64.029		-149.907	-162.24	-64.803		1.688	-1.03	0.774		2.123
-220.308	-29.845	-63.729		-222.07	-30.084	-63.777		1.762	0.239	0.049		1.778
-212.718	63.876	-70.943		-214.107	64.293	-71.119		1.389	-0.417	0.176		1.461
-167.779	146.584	-63.742		-168.762	147.443	-63.778		0.983	-0.858	0.036		1.305
-91.715	201.924	-70.904		-92.449	203.54	-71.12		0.734	-1.617	0.216		1.789
-194.63	-84.912	-98.979		-196.275	-85.63	-99.981		1.645	0.718	1.002		2.056
-210.682	-6.363	-102.099		-212.232	-6.409	-103.06		1.55	0.047	0.961		1.824
-184.449	108.623	-96.575		-185.738	109.382	-97.337		1.289	-0.759	0.762		1.679
-95.455	188.399	-101.118		-96.219	189.909	-102.135		0.765	-1.51	1.017		1.974
36.929	208.787	-100.097		37.198	210.305	-100.988		-0.269	-1.518	0.891		1.781
151.911	150.52	-97.041		152.949	151.55	-97.798		-1.039	-1.029	0.757		1.647
204.832	-66.238	-92.212		206.962	-66.926	-93.193		-2.13	0.689	0.981		2.444
118.753	-180.214	-89.052		120.366	-182.662	-90.195		-1.613	2.448	1.143		3.147
-124.662	-168.999	-102.114		-125.906	-170.686	-103.429		1.244	1.686	1.315		2.474
209.418	12.05	-71.141		209.71	11.022	-71.072		-0.292	1.029	-0.069		-1.071
141.475	-157.317	-73.29		140.792	-158.27	-73.22		0.683	0.952	-0.071		-1.174
-35.939	-208.443	-76.609		-36.163	-208.454	-76.597		0.225	0.011	-0.012		-0.225
-208.723	-42.648	-75.959		-208.52	-43.098	-75.987		-0.203	0.45	0.027		0.495

-117.419	179.048	-77.587	-117.157	179.317	-77.568	-0.263	-0.269	-0.02	-0.376
66.26	199.479	-75.796	66.653	199.44	-75.775	-0.392	0.04	-0.021	-0.395
63.702	204.198	-77.743	64.269	204.124	-77.733	-0.567	0.073	-0.01	0.571
-63.369	206.107	-77.924	-62.693	206.452	-77.908	-0.676	-0.345	-0.016	0.759
-184.697	-104.501	-80.144	-184.527	-104.709	-80.146	-0.17	0.208	0.002	-0.269
-94.952	-194.993	-70.987	-94.548	-195.1	-71.005	-0.404	0.107	0.017	-0.418
89.949	-188.973	-71.838	89.135	-189.566	-71.819	0.815	0.594	-0.019	1.008
204.049	-47.02	-75.1	203.967	-48.561	-75.084	0.083	1.541	-0.017	1.544
196.485	76.635	-77.376	197.155	75.517	-77.364	-0.671	1.118	-0.012	1.304
-66.712	-253.483	-0.247	-66.712	-253.483	0	0	0	-0.247	-0.247
-40.03	-253.483	-0.138	-40.03	-253.483	0	0	0	-0.138	-0.138
-13.347	-253.484	0.057	-13.347	-253.484	0	0	0	0.057	0.057
13.335	-253.484	-0.061	13.335	-253.484	0	0	0	-0.061	-0.061
40.016	-253.484	-0.069	40.016	-253.484	0	0	0	-0.069	-0.069
66.7	-253.483	-0.204	66.7	-253.483	0	0	0	-0.204	-0.204
120.064	-226.801	-0.134	120.064	-226.801	0	0	0	-0.134	-0.134
93.382	-226.804	-0.074	93.382	-226.804	0	0	0	-0.074	-0.074
-93.396	-226.804	-0.09	-93.396	-226.804	0	0	0	-0.09	-0.09
-120.079	-226.803	-0.228	-120.079	-226.803	0	0	0	-0.228	-0.228
-173.443	-200.118	-0.226	-173.443	-200.118	0	0	0	-0.226	-0.226
-146.76	-200.118	-0.144	-146.76	-200.118	0	0	0	-0.144	-0.144
146.747	-200.118	-0.097	146.747	-200.118	0	0	0	-0.097	-0.097
173.429	-200.118	-0.043	173.429	-200.118	0	0	0	-0.043	-0.043
200.112	-173.435	0.101	200.112	-173.435	0	0	0	0.101	0.101
173.429	-173.436	0.061	173.429	-173.436	0	0	0	0.061	0.061
-173.442	-173.438	-0.027	-173.442	-173.438	0	0	0	-0.027	-0.027
-200.125	-173.438	-0.086	-200.125	-173.438	0	0	0	-0.086	-0.086
-200.127	-146.752	0.137	-200.127	-146.752	0	0	0	0.137	0.137
200.112	-146.752	0.167	200.112	-146.752	0	0	0	0.167	0.167
226.795	-120.07	0.359	226.795	-120.07	0	0	0	0.359	0.359
-226.807	-120.072	0.374	-226.807	-120.072	0	0	0	0.374	0.374
-226.808	-93.389	0.349	-226.808	-93.389	0	0	0	0.349	0.349
226.794	-93.387	0.39	226.794	-93.387	0	0	0	0.39	0.39
253.477	-66.704	0.38	253.477	-66.704	0	0	0	0.38	0.38
-253.491	-66.705	0.279	-253.491	-66.705	0	0	0	0.279	0.279
-253.49	-40.024	0.234	-253.49	-40.024	0	0	0	0.234	0.234
253.478	-40.022	0.38	253.478	-40.022	0	0	0	0.38	0.38
253.476	-13.339	0.387	253.476	-13.339	0	0	0	0.387	0.387
-253.49	-13.34	0.139	-253.49	-13.34	0	0	0	0.139	0.139
-253.491	13.343	0.17	-253.491	13.343	0	0	0	0.17	0.17
253.477	13.344	0.457	253.477	13.344	0	0	0	0.457	0.457
253.475	40.028	0.388	253.475	40.028	0	0	0	0.388	0.388
-253.49	40.025	0.118	-253.49	40.025	0	0	0	0.118	0.118
-253.49	66.71	0.007	-253.49	66.71	0	0	0	0.007	0.007
253.477	66.71	0.444	253.477	66.71	0	0	0	0.444	0.444

226.794	93.393	0.45	226.794	93.393	0	0	0	0.45	0.45
-226.807	93.393	-0.507	-226.807	93.393	0	0	0	-0.507	-0.507
-226.807	120.076	-0.608	-226.807	120.076	0	0	0	-0.608	-0.608
226.795	120.076	0.608	226.795	120.076	0	0	0	0.608	0.608
200.111	146.759	0.363	200.111	146.759	0	0	0	0.363	0.363
-200.125	146.758	0.008	-200.125	146.758	0	0	0	0.008	0.008
-200.125	173.442	-0.191	-200.125	173.442	0	0	0	-0.191	-0.191
-173.442	173.441	-0.121	-173.442	173.441	0	0	0	-0.121	-0.121
173.43	173.442	0.233	173.43	173.442	0	0	0	0.233	0.233
200.111	173.441	0.227	200.111	173.441	0	0	0	0.227	0.227
173.428	200.125	0.082	173.428	200.125	0	0	0	0.082	0.082
146.747	200.123	0.141	146.747	200.123	0	0	0	0.141	0.141
-146.761	200.124	-0.14	-146.761	200.124	0	0	0	-0.14	-0.14
-173.443	200.123	-0.289	-173.443	200.123	0	0	0	-0.289	-0.289
-120.077	226.807	-0.219	-120.077	226.807	0	0	0	-0.219	-0.219
-93.395	226.807	-0.109	-93.395	226.807	0	0	0	-0.109	-0.109
93.382	226.807	0.079	93.382	226.807	0	0	0	0.079	0.079
120.065	226.808	0.051	120.065	226.808	0	0	0	0.051	0.051
66.699	253.49	-0.003	66.699	253.49	0	0	0	-0.003	-0.003
40.017	253.489	0.076	40.017	253.489	0	0	0	0.076	0.076
13.334	253.489	0.163	13.334	253.489	0	0	0	0.163	0.163
-13.348	253.489	0.186	-13.348	253.489	0	0	0	0.186	0.186
-40.031	253.491	-0.068	-40.031	253.491	0	0	0	-0.068	-0.068
-66.713	253.489	-0.172	-66.713	253.489	0	0	0	-0.172	-0.172



